

```
import numpy
from ODESolver import RungeKutta4
```

```
def rhs(u, t):
    R = 1
    return alpha*u*(1 - u/R)
```

$$\frac{du}{dt} = \alpha u(1 - u)$$

$$u(0) = 0.1$$

$$R = 1$$

$$\alpha = 0.2$$

TEXTS IN COMPUTATIONAL SCIENCE
AND ENGINEERING

6

Hans Petter Langtangen

A Primer on Scientific Programming with Python

Third Edition

Editorial Board

T. J. Barth

M. Griebel

D. E. Keyes

R. M. Nieminen

D. Roose

T. Schlick



Springer

Editors

Timothy J. Barth

Michael Griebel

David E. Keyes

Risto M. Nieminen

Dirk Roose

Tamar Schlick

Hans Petter Langtangen

A Primer on Scientific Programming with Python

Third Edition

 Springer

Hans Petter Langtangen
Simula Research Laboratory
Lysaker, Fornebu
Norway

On leave from:

Department of Informatics
University of Oslo
Oslo, Norway

ISSN 1611-0994 Texts in Computational Science and Engineering
ISBN 978-3-642-30292-3 ISBN 978-3-642-30293-0 (eBook)
DOI 10.1007/978-3-642-30293-0
Springer Heidelberg New York Dordrecht London

Library of Congress Control Number: 2012942179

Mathematics Subject Classification (2000): 26-01, 34A05, 34A30, 34A34, 39-01, 40-01, 65D15, 65D25, 65D30, 68-01, 68N01, 68N19, 68N30, 70-01, 92D25, 97-04, 97U50

© Springer-Verlag Berlin Heidelberg 2009, 2011, 2012

This work is subject to copyright. All rights are reserved by the Publisher, whether the whole or part of the material is concerned, specifically the rights of translation, reprinting, reuse of illustrations, recitation, broadcasting, reproduction on microfilms or in any other physical way, and transmission or information storage and retrieval, electronic adaptation, computer software, or by similar or dissimilar methodology now known or hereafter developed. Exempted from this legal reservation are brief excerpts in connection with reviews or scholarly analysis or material supplied specifically for the purpose of being entered and executed on a computer system, for exclusive use by the purchaser of the work. Duplication of this publication or parts thereof is permitted only under the provisions of the Copyright Law of the Publisher's location, in its current version, and permission for use must always be obtained from Springer. Permissions for use may be obtained through RightsLink at the Copyright Clearance Center. Violations are liable to prosecution under the respective Copyright Law.

The use of general descriptive names, registered names, trademarks, service marks, etc. in this publication does not imply, even in the absence of a specific statement, that such names are exempt from the relevant protective laws and regulations and therefore free for general use.

While the advice and information in this book are believed to be true and accurate at the date of publication, neither the authors nor the editors nor the publisher can accept any legal responsibility for any errors or omissions that may be made. The publisher makes no warranty, express or implied, with respect to the material contained herein.

Printed on acid-free paper

Springer is part of Springer Science+Business Media (www.springer.com)

Preface

The aim of this book is to teach computer programming using examples from mathematics and the natural sciences. We have chosen to use the Python programming language because it combines remarkable expressive power with very clean, simple, and compact syntax. Python is easy to learn and very well suited for an introduction to computer programming. Python is also quite similar to Matlab and a good language for doing mathematical computing. It is easy to combine Python with compiled languages, like Fortran, C, and C++, which are widely used languages for scientific computations. A seamless integration of Python with Java is offered by a special version of Python called Jython.

The examples in this book integrate programming with applications to mathematics, physics, biology, and finance. The reader is expected to have knowledge of basic one-variable calculus as taught in mathematics-intensive programs in high schools. It is certainly an advantage to take a university calculus course in parallel, preferably containing both classical and numerical aspects of calculus. Although not strictly required, a background in high school physics makes many of the examples more meaningful.

Many introductory programming books are quite compact and focus on listing functionality of a programming language. However, learning to program is learning how to *think* as a programmer. This book has its main focus on the thinking process, or equivalently: programming as a problem solving technique. That is why most of the pages are devoted to case studies in programming, where we define a problem and explain how to create the corresponding program. New constructions and programming styles (what we could call theory) is also usually introduced via examples. Special attention is paid to verification of programs and to finding errors. These topics are very demanding for mathematical software, because the unavoidable numerical approximation errors are possibly mixed with programming mistakes.

By studying the many examples in the book, I hope readers will learn how to think right and thereby write programs in a quicker and more reliable way. Remember, nobody can learn programming by just reading – one has to solve a large amount of exercises hands on. The book is therefore full of exercises of various types: modifications of existing examples, completely new problems, or debugging of given programs.

To work with this book, I recommend to use Python version 2.7 (although version 2.6 will work for most of the material). For Chapters 5–9 and Appendices A–E you need the NumPy, Matplotlib, SciTools packages, and for Appendix G Cython is also required. There is a web page associated with this book, <http://hplgit.github.com/scipro-primer>, which lists the software you need and explains briefly how to install it. This page also contains all the files associated with the program examples in this book.

Python Version 2 or 3? A common problem among Python programmers is to choose between version 2 or 3, which at the time of this writing means choosing between version 2.7 and 3.3. The general recommendation is to go for version 3, but programs are then not compatible with version 2 and vice versa. There is still a problem that much useful mathematical software in Python has not yet been ported to version 3. Therefore, scientific computing with Python still goes mostly with version 2. A widely used strategy for software developers who want to write Python code that works with both versions, is to develop for v2.7, which is very close to what is accepted in version 3, and then use the translation tool *2to3* to automatically translate the code to version 3.

When using v2.7, one should employ the newest syntax and modules that make the differences between version 2 and 3 very small. This strategy is adopted in the present book. Only two differences between versions 2 and 3 are expected to be significant for the programs in the book: `a/b` implies float division in version 3 if `a` and `b` are integers, and `print 'Hello'` in version 2 must be turned into a function call `print('Hello')` in version 3. None of these differences should lead to any annoying problems when future readers study the book's v2.7 examples, but program in version 3. Anyway, running *2to3* on the example files generates the corresponding version 3 code.

Contents. Chapter 1 introduces variables, objects, modules, and text formatting through examples concerning evaluation of mathematical formulas. Chapter 2 presents programming with `while` and `for` loops as well as lists, including nested lists. The next chapter deals with two other fundamental concepts in programming: functions and `if-else` tests. Successful further reading of the book demands that Chapters 1–3 are digested.

How to read data into programs and deal with errors in input are the subjects of Chapter 4. Chapter 5 introduces arrays and array computing (including vectorization) and how this is used for plotting $y = f(x)$ curves and making animation of curves. Many of the examples in the first five chapters are strongly related. Typically, formulas from the first chapter are used to produce tables of numbers in the second chapter. Then the formulas are encapsulated in functions in the third chapter. In the next chapter, the input to the functions are fetched from the command line, or from a question-answer dialog with the user, and validity checks of the input are added. The formulas are then shown as graphs in Chapter 5. After having studied Chapters 1–5, the reader should have enough knowledge of programming to solve mathematical problems by what many refer to as “Matlab-style” programming.

Chapter 6 explains how to work with files and text data. Class programming, including user-defined types for mathematical computations (with overloaded operators), is introduced in Chapter 7. Chapter 8 deals with random numbers and statistical computing with applications to games and random walks. Object-oriented programming, in the meaning of class hierarchies and inheritance, is the subject of Chapter 9. The key examples here deal with building toolkits for numerical differentiation and integration as well as graphics.

Appendix A introduces mathematical modeling, using sequences and difference equations. We also treat sound as a sequence. Only programming concepts from Chapters 1–5 are used in this appendix, the aim being to consolidate basic programming knowledge and apply it to mathematical problems. Some important mathematical topics are introduced via difference equations in a simple way: Newton’s method, Taylor series, inverse functions, and dynamical systems.

Appendix B deals with functions on a mesh, numerical differentiation, and numerical integration. A simple introduction to ordinary differential equations and their numerical treatment is provided in Appendix C. Appendix D shows how a complete project in physics can be solved by mathematical modeling, numerical methods, and programming elements from Chapters 1–5. This project is a good example on problem solving in computational science, where it is necessary to integrate physics, mathematics, numerics, and computer science.

How to create software for solving systems of ordinary differential equations, primarily using classes and object-oriented programming, is the subject of Appendix E. The material in this appendix brings together many of the programming concepts from Chapters 1–9 in a mathematical setting and ends up with a flexible and general tool for solving differential equations.

Appendix F is devoted to the art of debugging, and in fact problem solving in general. Speeding up numerical computations in Python by

migrating code to C via Cython is exemplified in Appendix G. Finally, Appendix H deals with various more advanced technical topics.

Most of the examples and exercises in this book are quite short. However, many of the exercises are related, and together they form larger projects, for example on Fourier Series (3.13, 4.18–4.20, 5.30, 5.31), numerical integration (3.5–3.8, 5.38–5.39, A.16), Taylor series (3.30, 5.21, 5.28, A.18–A.19, 7.29), piecewise constant functions (3.24–3.28, 5.23, 5.36–5.37, 7.19–7.25), inverse functions (7.26, E.7–E.10), falling objects (E.11–E.13, E.31–E.32), oscillatory population growth (A.23–A.25, 7.40–7.41), epidemic disease modeling (E.35–E.42), analysis of web data (6.22, 6.27–6.29), optimization and finance (A.26, 8.44–8.45), statistics and probability (4.24–4.26, 8.23–8.25), hazard games (8.8–8.14), random walk and statistical physics (8.34–8.42), noisy data analysis (8.46–8.50), numerical methods (5.14–5.16, 7.8–7.9, A.12, 7.28, 9.16–9.18, E.21–E.29), building a calculus calculator (7.42, 7.43, 9.19, 9.20), and creating a toolkit for simulating vibrating engineering systems (E.44–E.49).

Chapters 1–9 and Appendix E have from 2007 formed the core of an introductory first semester course on scientific programming (INF1100) at the University of Oslo.

Changes to the First Edition. Besides numerous corrections of misprints, the second edition features a major reorganization of several chapters. Chapter 2 in the first edition, *Basic Constructions*, was a comprehensive chapter, both with respect to length and topics. This chapter has therefore been split in two for the second edition: a new Chapter 2 *Loops and Lists* and a new Chapter 3 *Functions and Branching*. A new Chapter 2.1.4 explicitly explains how to implement a summation expression by a loop, and later examples present alternative implementations.

All text and program files that used the `getopt` module to parse command-line options in the first edition now make use of the simpler and more flexible `argparse` module (new in Python v2.7/3.1). The material on curve plotting in Chapter 5 has been thoroughly revised. Now we give an introduction to plotting with Matplotlib as well as SciTools/Easyviz.

While the first edition almost exclusively used “star import” for convenience (e.g., `from numpy import *` and `from scitools.std import *`), the second edition tries to adhere to the standard `import numpy as np`. However, in mathematical formulas that are to work with scalar *and* array variables, we do not want an explicit prefix. Avoiding the namespace prefixes is important for making formulas as close to the mathematical notation as possible as well as for making the transition from or to Matlab smooth. The two import styles have different merits and applications. The choice of style in various examples is carefully thought through in the second edition.

Chapter 5 in the first edition, *Sequences and Difference Equations*, has now become Appendix A. Chapter 6 in the first edition, *Files, Strings, and Dictionaries*, has been substantially revised. Chapter 6.4 on downloading and interpreting data from web pages have now completely new examples. Exercises are also reworked to fit with the new examples.

The material on differential equations in chapters on classes (Ch. 7 and 9 in the first edition) has been extracted, reworked, slightly expanded, and placed in Appendix E. This restructuring allows a more flexible treatment of differential equations, and parts of this important topic can be addressed right after Chapter 3, if desired.

To distinguish between Python's `random` module and the one in `numpy`, we have in Chapter 8 changed practice compared with the first edition. Now `random` always refers to Python's `random` module, while the `random` module in `numpy` is normally invoked as `np.random` (or occasionally as `numpy.random`). The associated software has been revised similarly.

Changes to the Second Edition. Many typos have been fixed in the third edition, a lot of examples have been improved, some material has been reorganized and extended, some material is new, several exercises have been removed and many new ones added, and numerous exercises are reformulated after feedback from teachers. The associated SciTools package is also extensively upgraded.

The reorganized and extended material covers Chapter 4.2.4 on command-line parsing, Chapter 5.5 on vectorization, and Appendix E.2.8 on building simulation software for ODEs. The new material consists of Chapter 6.2.4 on dictionaries with default values and ordering, Chapter 9.4 on making a drawing program, Appendix A.1.7 on integrals as difference equations, Appendix G on using Cython and combining Python with fast C code, and the bioinformatics examples in Chapters 3.3, 6.6, 8.3.4, and 9.5.

Four new projects are added: numerical integration (Exercises 3.5–3.8, 5.38–5.39, A.16), piecewise constant functions (Exercises 3.24–3.28, 5.23, 5.36–5.37, 7.19–7.25), inverse functions (Exercises 7.26, E.7–E.10), and epidemic modeling (Exercises E.35–E.42).

The software for ODEs derived in Appendix E and the drawing program from Chapter 9.4 have been much further developed into the packages `Odespy` and `Pysketcher`, both available from github.com.

Acknowledgments. First, I want to express my thanks to Aslak Tveito for his enthusiastic role in the initiation of this book project and for writing Appendices B and C about numerical methods. Without Aslak there would be no book. Another key contributor is Ilmar Wilbers. His extensive efforts with assisting the book project and help establishing the associated course (INF1100) at the University of Oslo are

greatly appreciated. Without Ilmar and his solutions to numerous technical problems the book would never have been completed. Johannes H. Ring also deserves a special acknowledgment for the development of the Easyviz graphics tool and for his careful maintenance and support of software associated with the book. Professor Loyce Adams studied the entire book, solved all the exercises, found numerous errors, and suggested many improvements. Her contributions are so much appreciated. I also want to thank Geir Kjetil Sandve for being the primary author of the third edition's new series of computational bioinformatics examples in Chapters 3.3, 6.6, 8.3.4, and 9.5, with contributions from Sveinung Gundersen, Ksenia Khelik, Halfdan Rydbeck, and Kai Trengereid.

Several people have helped to make substantial improvements of the text, the exercises, and the associated software components. The author is thankful to Ingrid Eide, Ståle Zerener Haugnæss, Kristian Hiorth, Arve Knudsen, Tobias Vidarssønn Langhoff, Martin Vonheim Larsen, Kine Veronica Lund, Solveig Masvie, Håkon Møller, Rebekka Mørken, Mathias Nedrebø, Marit Sandstad, Helene Norheim Semmerud, Lars Storjord, Fredrik Heffer Valdmanis, and Torkil Vederhus for their contributions. Hakon Adler is greatly acknowledged for his careful reading of early various versions of the manuscript. The professors Fred Espen Bent, Ørnulf Borgan, Geir Dahl, Knut Mørken, and Geir Pedersen have contributed with many exciting exercises from various application fields. Great thanks also go to Jan Olav Langseth for creating the cover image.

This book and the associated course are parts of a comprehensive reform at the University of Oslo, called *Computing in Science Education*. The goal of the reform is to integrate computer programming and simulation in all bachelor courses in natural science where mathematical models are used. The present book lays the foundation for the modern computerized problem solving technique to be applied in later courses. It has been extremely inspiring to work with the driving forces behind this reform, especially the professors Morten Hjorth-Jensen, Anders Malthe-Sørensen, Knut Mørken, and Arnt Inge Vistnes.

The excellent assistance from the Springer system, in particular Martin Peters, Thanh-Ha Le Thi, Ruth Allewelt, Peggy Glauch-Ruge, Nadja Kroke, Thomas Schmidt, Patrick Waltemate, Donatas Akmanavičius, and Edita Baronaitė, is highly appreciated, and ensured a smooth and rapid production of all editions of this book.

Oslo

Hans Petter Langtangen

Contents

1	Computing with Formulas	1
1.1	The First Programming Encounter: A Formula	1
1.1.1	Using a Program as a Calculator	2
1.1.2	About Programs and Programming	2
1.1.3	Tools for Writing Programs	3
1.1.4	Using Idle to Write the Program	4
1.1.5	How to Run the Program	7
1.1.6	Verifying the Result	8
1.1.7	Using Variables	8
1.1.8	Names of Variables	9
1.1.9	Reserved Words in Python	10
1.1.10	Comments	10
1.1.11	Formatting Text and Numbers	11
1.2	Computer Science Glossary	14
1.3	Another Formula: Celsius-Fahrenheit Conversion	19
1.3.1	Potential Error: Integer Division	19
1.3.2	Objects in Python	20
1.3.3	Avoiding Integer Division	21
1.3.4	Arithmetic Operators and Precedence	22
1.4	Evaluating Standard Mathematical Functions	23
1.4.1	Example: Using the Square Root Function	23
1.4.2	Example: Using More Mathematical Functions	25
1.4.3	A First Glimpse of Round-Off Errors	26
1.5	Interactive Computing	27
1.5.1	Using the Python Shell	27
1.5.2	Type Conversion	28
1.5.3	IPython	29
1.6	Complex Numbers	32
1.6.1	Complex Arithmetics in Python	33

1.6.2	Complex Functions in Python	33
1.6.3	Unified Treatment of Complex and Real Functions	34
1.7	Summary	35
1.7.1	Chapter Topics	35
1.7.2	Example: Trajectory of a Ball	39
1.7.3	About Typesetting Conventions in This Book	40
1.8	Exercises	41
2	Loops and Lists	49
2.1	While Loops	49
2.1.1	A Naive Solution	49
2.1.2	While Loops	50
2.1.3	Boolean Expressions	52
2.1.4	Loop Implementation of a Sum	54
2.2	Lists	55
2.2.1	Basic List Operations	55
2.2.2	For Loops	58
2.3	Alternative Implementations with Lists and Loops	60
2.3.1	While Loop Implementation of a For Loop	60
2.3.2	The Range Construction	60
2.3.3	For Loops with List Indices	61
2.3.4	Changing List Elements	63
2.3.5	List Comprehension	63
2.3.6	Traversing Multiple Lists Simultaneously	64
2.4	Nested Lists	64
2.4.1	A Table as a List of Rows or Columns	65
2.4.2	Printing Objects	66
2.4.3	Extracting Sublists	67
2.4.4	Traversing Nested Lists	69
2.5	Tuples	71
2.6	Summary	72
2.6.1	Chapter Topics	72
2.6.2	Example: Analyzing List Data	75
2.6.3	How to Find More Python Information	78
2.7	Exercises	79
3	Functions and Branching	87
3.1	Functions	87
3.1.1	Functions of One Variable	87
3.1.2	Local and Global Variables	89
3.1.3	Multiple Arguments	91
3.1.4	Multiple Return Values	93
3.1.5	Functions with No Return Values	95
3.1.6	Keyword Arguments	96
3.1.7	Doc Strings	99

3.1.8	Function Input and Output	100
3.1.9	Functions as Arguments to Functions	100
3.1.10	The Main Program	102
3.1.11	Lambda Functions	103
3.2	Branching	104
3.2.1	If-Else Blocks	104
3.2.2	Inline If Tests	106
3.3	Mixing Loops, Branching, and Functions in Bioinformatics Examples	107
3.3.1	Counting Letters in DNA Strings	107
3.3.2	Efficiency Assessment	113
3.4	Summary	115
3.4.1	Chapter Topics	115
3.4.2	Example: Numerical Integration	116
3.5	Exercises	120
4	Input Data and Error Handling	137
4.1	Asking Questions and Reading Answers	138
4.1.1	Reading Keyboard Input	138
4.1.2	The Magic “eval” Function	139
4.1.3	The Magic “exec” Function	143
4.1.4	Turning String Expressions into Functions	144
4.2	Reading from the Command Line	145
4.2.1	Providing Input on the Command Line	145
4.2.2	A Variable Number of Command-Line Arguments	146
4.2.3	More on Command-Line Arguments	147
4.2.4	Option–Value Pairs on the Command Line	148
4.3	Handling Errors	152
4.3.1	Exception Handling	153
4.3.2	Raising Exceptions	156
4.4	A Glimpse of Graphical User Interfaces	158
4.5	Making Modules	161
4.5.1	Example: Interest on Bank Deposits	161
4.5.2	Collecting Functions in a Module File	162
4.5.3	Using Modules	167
4.6	Summary	169
4.6.1	Chapter Topics	169
4.6.2	Example: Bisection Root Finding	172
4.7	Exercises	180
5	Array Computing and Curve Plotting	187
5.1	Vectors	188
5.1.1	The Vector Concept	188
5.1.2	Mathematical Operations on Vectors	189
5.1.3	Vector Arithmetics and Vector Functions	191

5.2	Arrays in Python Programs	193
5.2.1	Using Lists for Collecting Function Data	193
5.2.2	Basics of Numerical Python Arrays	194
5.2.3	Computing Coordinates and Function Values	195
5.2.4	Vectorization	196
5.3	Curve Plotting	198
5.3.1	Matplotlib; Pylab	198
5.3.2	Matplotlib; Pyplot	202
5.3.3	SciTools and Easyviz	204
5.3.4	Making Animations	209
5.3.5	Curves in Pure Text	214
5.4	Plotting Difficulties	215
5.4.1	Piecewisely Defined Functions	216
5.4.2	Rapidly Varying Functions	218
5.5	More Advanced Vectorization of Functions	219
5.5.1	Vectorizing StringFunction Objects	220
5.5.2	Vectorization of the Heaviside Function	221
5.5.3	Vectorization of a Hat Function	224
5.6	More on Numerical Python Arrays	226
5.6.1	Copying Arrays	226
5.6.2	In-Place Arithmetics	227
5.6.3	Allocating Arrays	228
5.6.4	Generalized Indexing	228
5.6.5	Testing for the Array Type	229
5.6.6	Compact Syntax for Array Generation	230
5.6.7	Shape Manipulation	230
5.7	Higher-Dimensional Arrays	231
5.7.1	Matrices and Arrays	231
5.7.2	Two-Dimensional Numerical Python Arrays	232
5.7.3	Array Computing	235
5.7.4	Two-Dimensional Arrays and Functions of Two Variables	235
5.7.5	Matrix Objects	236
5.8	Summary	237
5.8.1	Chapter Topics	237
5.8.2	Example: Animating a Function	239
5.9	Exercises	243
6	Files, Strings, and Dictionaries	257
6.1	Reading Data from File	257
6.1.1	Reading a File Line by Line	258
6.1.2	Reading a Mixture of Text and Numbers	261
6.1.3	What Is a File, Really?	262
6.2	Dictionaries	266
6.2.1	Making Dictionaries	266

6.2.2	Dictionary Operations	267
6.2.3	Example: Polynomials as Dictionaries	269
6.2.4	Dictionaries with Default Values and Ordering	271
6.2.5	Example: File Data in Dictionaries	273
6.2.6	Example: File Data in Nested Dictionaries	274
6.2.7	Example: Comparing Stock Prices	278
6.3	Strings	282
6.3.1	Common Operations on Strings	282
6.3.2	Example: Reading Pairs of Numbers	286
6.3.3	Example: Reading Coordinates	288
6.4	Reading Data from Web Pages	291
6.4.1	About Web Pages	291
6.4.2	How to Access Web Pages in Programs	292
6.4.3	Example: Reading Pure Text Files	293
6.4.4	Example: Extracting Data from HTML	295
6.5	Writing Data to File	296
6.5.1	Example: Writing a Table to File	296
6.5.2	Standard Input and Output as File Objects	298
6.5.3	Reading and Writing Spreadsheet Files	300
6.6	Examples from Analyzing DNA	305
6.6.1	Computing Frequencies	305
6.6.2	Analyzing the Frequency Matrix	312
6.6.3	Finding Base Frequencies	315
6.6.4	Translating Genes into Proteins	317
6.6.5	Some Humans Can Drink Milk, While Others Cannot	322
6.7	Summary	323
6.7.1	Chapter Topics	323
6.7.2	Example: A File Database	325
6.8	Exercises	329
7	Introduction to Classes	341
7.1	Simple Function Classes	342
7.1.1	Problem: Functions with Parameters	342
7.1.2	Representing a Function as a Class	344
7.1.3	Another Function Class Example	350
7.1.4	Alternative Function Class Implementations	351
7.1.5	Making Classes Without the Class Construct	353
7.2	More Examples on Classes	356
7.2.1	Bank Accounts	356
7.2.2	Phone Book	358
7.2.3	A Circle	359
7.3	Special Methods	360
7.3.1	The Call Special Method	361
7.3.2	Example: Automagic Differentiation	361

7.3.3	Example: Automagic Integration	364
7.3.4	Turning an Instance into a String	366
7.3.5	Example: Phone Book with Special Methods	367
7.3.6	Adding Objects	369
7.3.7	Example: Class for Polynomials	369
7.3.8	Arithmetic Operations and Other Special Methods	373
7.3.9	Special Methods for String Conversion	374
7.4	Example: Class for Vectors in the Plane	375
7.4.1	Some Mathematical Operations on Vectors	376
7.4.2	Implementation	376
7.4.3	Usage	378
7.5	Example: Class for Complex Numbers	379
7.5.1	Implementation	380
7.5.2	Illegal Operations	381
7.5.3	Mixing Complex and Real Numbers	382
7.5.4	Special Methods for “Right” Operands	384
7.5.5	Inspecting Instances	386
7.6	Static Methods and Attributes	387
7.7	Summary	388
7.7.1	Chapter Topics	388
7.7.2	Example: Interval Arithmetics	389
7.8	Exercises	395
8	Random Numbers and Simple Games	413
8.1	Drawing Random Numbers	414
8.1.1	The Seed	414
8.1.2	Uniformly Distributed Random Numbers	415
8.1.3	Visualizing the Distribution	416
8.1.4	Vectorized Drawing of Random Numbers	417
8.1.5	Computing the Mean and Standard Deviation	418
8.1.6	The Gaussian or Normal Distribution	419
8.2	Drawing Integers	420
8.2.1	Random Integer Functions	421
8.2.2	Example: Throwing a Die	422
8.2.3	Drawing a Random Element from a List	422
8.2.4	Example: Drawing Cards from a Deck	423
8.2.5	Example: Class Implementation of a Deck	425
8.3	Computing Probabilities	428
8.3.1	Principles of Monte Carlo Simulation	428
8.3.2	Example: Throwing Dice	429
8.3.3	Example: Drawing Balls from a Hat	432
8.3.4	Random Mutations of Genes	434
8.3.5	Example: Policies for Limiting Population Growth	439
8.4	Simple Games	442

8.4.1	Guessing a Number	442
8.4.2	Rolling Two Dice	443
8.5	Monte Carlo Integration	446
8.5.1	Standard Monte Carlo Integration	446
8.5.2	Area Computing by Throwing Random Points	448
8.6	Random Walk in One Space Dimension	450
8.6.1	Basic Implementation	451
8.6.2	Visualization	452
8.6.3	Random Walk as a Difference Equation	452
8.6.4	Computing Statistics of the Particle Positions	453
8.6.5	Vectorized Implementation	454
8.7	Random Walk in Two Space Dimensions	456
8.7.1	Basic Implementation	456
8.7.2	Vectorized Implementation	457
8.8	Summary	459
8.8.1	Chapter Topics	459
8.8.2	Example: Random Growth	460
8.9	Exercises	466
9	Object-Oriented Programming	483
9.1	Inheritance and Class Hierarchies	483
9.1.1	A Class for Straight Lines	484
9.1.2	A First Try on a Class for Parabolas	485
9.1.3	A Class for Parabolas Using Inheritance	485
9.1.4	Checking the Class Type	487
9.1.5	Attribute Versus Inheritance	488
9.1.6	Extending Versus Restricting Functionality	489
9.1.7	Superclass for Defining an Interface	490
9.2	Class Hierarchy for Numerical Differentiation	492
9.2.1	Classes for Differentiation	493
9.2.2	A Flexible Main Program	496
9.2.3	Extensions	497
9.2.4	Alternative Implementation via Functions	500
9.2.5	Alternative Implementation via Functional Programming	501
9.2.6	Alternative Implementation via a Single Class	502
9.3	Class Hierarchy for Numerical Integration	504
9.3.1	Numerical Integration Methods	504
9.3.2	Classes for Integration	505
9.3.3	Using the Class Hierarchy	509
9.3.4	About Object-Oriented Programming	511
9.4	Class Hierarchy for Making Drawings	513
9.4.1	Using the Object Collection	514
9.4.2	Example of Classes for Geometric Objects	523
9.4.3	Adding Functionality via Recursion	528

9.4.4	Scaling, Translating, and Rotating a Figure	531
9.5	Classes for DNA Analysis	534
9.5.1	Class for Regions	534
9.5.2	Class for Genes	534
9.5.3	Subclasses	539
9.6	Summary	541
9.6.1	Chapter Topics	541
9.6.2	Example: Input Data Reader	542
9.7	Exercises	548
A	Sequences and Difference Equations	557
A.1	Mathematical Models Based on Difference Equations . .	558
A.1.1	Interest Rates	559
A.1.2	The Factorial as a Difference Equation	561
A.1.3	Fibonacci Numbers	562
A.1.4	Growth of a Population	563
A.1.5	Logistic Growth	564
A.1.6	Payback of a Loan	566
A.1.7	The Integral as a Difference Equation	567
A.1.8	Taylor Series as a Difference Equation	569
A.1.9	Making a Living from a Fortune	571
A.1.10	Newton's Method	571
A.1.11	The Inverse of a Function	575
A.2	Programming with Sound	577
A.2.1	Writing Sound to File	578
A.2.2	Reading Sound from File	579
A.2.3	Playing Many Notes	580
A.2.4	Music of a Sequence	580
A.3	Exercises	583
B	Introduction to Discrete Calculus	593
B.1	Discrete Functions	593
B.1.1	The Sine Function	594
B.1.2	Interpolation	596
B.1.3	Evaluating the Approximation	596
B.1.4	Generalization	597
B.2	Differentiation Becomes Finite Differences	599
B.2.1	Differentiating the Sine Function	600
B.2.2	Differences on a Mesh	600
B.2.3	Generalization	602
B.3	Integration Becomes Summation	603
B.3.1	Dividing into Subintervals	604
B.3.2	Integration on Subintervals	605
B.3.3	Adding the Subintervals	606
B.3.4	Generalization	607

B.4	Taylor Series	609
B.4.1	Approximating Functions Close to One Point....	609
B.4.2	Approximating the Exponential Function	609
B.4.3	More Accurate Expansions	610
B.4.4	Accuracy of the Approximation	612
B.4.5	Derivatives Revisited	614
B.4.6	More Accurate Difference Approximations	615
B.4.7	Second-Order Derivatives	617
B.5	Exercises	619
C	Introduction to Differential Equations	625
C.1	The Simplest Case	626
C.2	Exponential Growth	628
C.3	Logistic Growth	633
C.4	A Simple Pendulum	634
C.5	A Model for the Spread of a Disease	637
C.6	Exercises	639
D	A Complete Differential Equation Project	641
D.1	About the Problem: Motion and Forces in Physics	641
D.1.1	The Physical Problem	641
D.1.2	The Computational Algorithm	644
D.1.3	Derivation of the Mathematical Model	644
D.1.4	Derivation of the Algorithm	646
D.2	Program Development and Testing	648
D.2.1	Implementation	648
D.2.2	Callback Functionality	651
D.2.3	Making a Module	652
D.2.4	Verification	653
D.3	Visualization	655
D.3.1	Simultaneous Computation and Plotting	655
D.3.2	Some Applications	658
D.3.3	Remark on Choosing Δt	658
D.3.4	Comparing Several Quantities in Subplots	659
D.3.5	Comparing Approximate and Exact Solutions ...	660
D.3.6	Evolution of the Error as Δt Decreases	661
D.4	Exercises	665
E	Programming of Differential Equations	667
E.1	Scalar Ordinary Differential Equations	668
E.1.1	Examples on Right-Hand-Side Functions	668
E.1.2	The Forward Euler Scheme	670
E.1.3	Function Implementation	671
E.1.4	Verifying the Implementation	671
E.1.5	From Discrete to Continuous Solution	672
E.1.6	Switching Numerical Method	673

E.1.7	Class Implementation	674
E.1.8	Example: Logistic Growth	677
E.2	Systems of Ordinary Differential Equations	677
E.2.1	Mathematical Problem	678
E.2.2	Example of a System of ODEs	680
E.2.3	From Scalar ODE Code to Systems	681
E.2.4	Numerical Methods	684
E.2.5	The ODE Solver Class Hierarchy	685
E.2.6	The Backward Euler Method	688
E.2.7	Application 1: $u' = -u$	691
E.2.8	Application 2: The Logistic Equation.....	693
E.2.9	Application 3: An Oscillating System.....	700
E.2.10	Application 4: The Trajectory of a Ball.....	702
E.2.11	Further Developments of ODESolver	704
E.3	Exercises	705
F	Debugging	735
F.1	Using a Debugger	735
F.2	How to Debug	738
F.2.1	A Recipe for Program Writing and Debugging ..	738
F.2.2	Application of the Recipe	740
G	Migrating Python to Compiled Code	753
G.1	Pure Python Code for Monte Carlo Simulation.....	754
G.1.1	The Computational Problem	754
G.1.2	A Scalar Python Implementation	754
G.1.3	A Vectorized Python Implementation	755
G.2	Migrating Scalar Python Code to Cython	757
G.2.1	A Plain Cython Implementation	757
G.2.2	A Better Cython Implementation	759
G.3	Migrating Code to C	761
G.3.1	Writing a C Program	761
G.3.2	Migrating Loops to C Code via F2PY	762
G.3.3	Migrating Loops to C Code via Cython.....	764
G.3.4	Comparing Efficiency	765
H	Technical Topics	767
H.1	Different Ways of Running Python Programs	767
H.1.1	Executing Python Programs in IPython	767
H.1.2	Executing Python Programs on Unix.....	767
H.1.3	Executing Python Programs on Windows	769
H.1.4	Executing Python Programs on Macintosh	771
H.1.5	Making a Complete Stand-Alone Executable ...	771
H.2	Integer and Float Division	771
H.3	Visualizing a Program with Lumpy	772
H.4	Doing Operating System Tasks in Python	774

H.5 Variable Number of Function Arguments	776
H.5.1 Variable Number of Positional Arguments	777
H.5.2 Variable Number of Keyword Arguments	779
H.6 Evaluating Program Efficiency	781
H.6.1 Making Time Measurements	781
H.6.2 Profiling Python Programs	783
References	785
Index	787

List of Exercises

Exercise 1.1	Compute $1+1$	43
Exercise 1.2	Write a “Hello, World!” program	43
Exercise 1.3	Derive and compute a formula	43
Exercise 1.4	Convert from meters to British length units	43
Exercise 1.5	Compute the mass of various substances	43
Exercise 1.6	Compute the growth of money in a bank	43
Exercise 1.7	Find error(s) in a program	44
Exercise 1.8	Type in program text	44
Exercise 1.9	Type in programs and debug them	44
Exercise 1.10	Evaluate a Gaussian function	45
Exercise 1.11	Compute the air resistance on a football	45
Exercise 1.12	How to cook the perfect egg	46
Exercise 1.13	Derive the trajectory of a ball	46
Exercise 1.14	Find errors in the coding of formulas	47
Exercise 1.15	Explain why a program does not work	47
Exercise 1.16	Find errors in Python statements	47
Exercise 1.17	Find errors in the coding of a formula	48
Exercise 2.1	Make a Fahrenheit–Celsius conversion table	79
Exercise 2.2	Write an approximate Fahrenheit–Celsius conversion table	79
Exercise 2.3	Generate odd numbers	79
Exercise 2.4	Store odd numbers in a list	79
Exercise 2.5	Generate odd numbers by a list comprehension	80
Exercise 2.6	Make a table of values from a formula	80
Exercise 2.7	Store values from a formula in lists	80
Exercise 2.8	Work with a list	80
Exercise 2.9	Simulate operations on lists by hand	80
Exercise 2.10	Generate equally spaced coordinates	80
Exercise 2.11	Use a list comprehension to solve Exer. 2.10	81
Exercise 2.12	Compute a mathematical sum	81

Exercise 2.13	Use a for loop in Exer. 2.12	81
Exercise 2.14	Simulate a program by hand.	81
Exercise 2.15	Explore the Python Library Reference	82
Exercise 2.16	Index a nested lists	82
Exercise 2.17	Construct a double for loop over a nested list	82
Exercise 2.18	Store data in lists in Exercise 2.2	82
Exercise 2.19	Store data from Exer. 2.7 in a nested list	82
Exercise 2.20	Convert nested list comprehensions to nested standard loops	83
Exercise 2.21	Values of boolean expressions	83
Exercise 2.22	Explore round-off errors from a large number of inverse operations	83
Exercise 2.23	Explore what zero can be on a computer	84
Exercise 2.24	Compare two real numbers on a computer	84
Exercise 2.25	Interpret a code	84
Exercise 2.26	Explore problems with inaccurate indentation	85
Exercise 2.27	Simulate nested loops by hand	85
Exercise 2.28	Explore punctuation in Python programs	86
Exercise 2.29	Investigate a for loop over a changing list	86
Exercise 3.1	Write a Fahrenheit–Celsius conversion function	120
Exercise 3.2	Write the program in Exer. 2.12 as a function	120
Exercise 3.3	Write a function for solving $ax^2 + bx + c = 0$	120
Exercise 3.4	Implement the sum function	120
Exercise 3.5	Integrate a function by one trapezoid	121
Exercise 3.6	Integrate a function by two trapezoids	121
Exercise 3.7	Derive the general Trapezoidal integration rule	121
Exercise 3.8	Derive the general Midpoint integration rule	122
Exercise 3.9	Compute the area of an arbitrary triangle	122
Exercise 3.10	Compute the length of a path	123
Exercise 3.11	Approximate π	123
Exercise 3.12	Write various hello-world functions	123
Exercise 3.13	Approximate a function by a sum of sines	124
Exercise 3.14	Implement a Gaussian function	124
Exercise 3.15	Make a function of the formula in Exer. 1.12	124
Exercise 3.16	Write a function for numerical differentiation	125
Exercise 3.17	Make an adaptive Trapezoidal integration rule	125
Exercise 3.18	Compute a polynomial via a product	126
Exercise 3.19	Implement the factorial function	126
Exercise 3.20	Compute velocity and acceleration from position data; one dimension	126
Exercise 3.21	Compute velocity and acceleration from position data; two dimensions	127
Exercise 3.22	Find the max and min values of a function	127
Exercise 3.23	Find the max and min elements in a list	127
Exercise 3.24	Implement the Heaviside function	128

Exercise 3.25	Implement a smoothed Heaviside function	128
Exercise 3.26	Implement an indicator function	128
Exercise 3.27	Implement a piecewise constant function	128
Exercise 3.28	Apply indicator functions	129
Exercise 3.29	Rewrite a mathematical function	129
Exercise 3.30	Make a table for approximations of $\cos x$	130
Exercise 3.31	Use None in keyword arguments	130
Exercise 3.32	Write a sort function for a list of 4-tuples	131
Exercise 3.33	Find prime numbers	132
Exercise 3.34	Find pairs of characters	132
Exercise 3.35	Count substrings	132
Exercise 3.36	Explain why a program works	132
Exercise 3.37	Resolve a problem with a function	132
Exercise 3.38	Determine the types of some objects	133
Exercise 3.39	Explain the difference between if and elif	133
Exercise 3.40	Find an error in a program	134
Exercise 3.41	Find programming errors	134
Exercise 4.1	Make an interactive program	180
Exercise 4.2	Read from the command line in Exer. 4.1	180
Exercise 4.3	Use exceptions in Exer. 4.2	180
Exercise 4.4	Read input from the keyboard	180
Exercise 4.5	Read input from the command line	180
Exercise 4.6	Prompt the user for input to a formula	180
Exercise 4.7	Read command line input a formula	180
Exercise 4.8	Make the program from Exer. 4.7 safer	181
Exercise 4.9	Test more in the program from Exer. 4.7	181
Exercise 4.10	Raise an exception in Exer. 4.9	181
Exercise 4.11	Compute the distance it takes to stop a car	181
Exercise 4.12	Look up calendar functionality	181
Exercise 4.13	Use the StringFunction tool	181
Exercise 4.14	Extend a program from Ch. 4.2.1	181
Exercise 4.15	Why we test for specific exception types	182
Exercise 4.16	Make a simple module	182
Exercise 4.17	Make a useful main program for Exer. 4.16	182
Exercise 4.18	Make a module in Exer. 3.13	182
Exercise 4.19	Extend the module from Exer. 4.18	183
Exercise 4.20	Use options and values in Exer. 4.19	183
Exercise 4.21	Check if mathematical identities hold on a computer	183
Exercise 4.22	Improve input to the program in Exer. 4.21	183
Exercise 4.23	Apply the program from Exer. 4.22	184
Exercise 4.24	Compute the binomial distribution	184
Exercise 4.25	Apply the binomial distribution	185
Exercise 4.26	Compute probabilities with the Poisson distribution	185

Exercise 5.1	Fill lists with function values	243
Exercise 5.2	Fill arrays; loop version	244
Exercise 5.3	Fill arrays; vectorized version	244
Exercise 5.4	Plot a function	244
Exercise 5.5	Apply a function to a vector	244
Exercise 5.6	Simulate by hand a vectorized expression	245
Exercise 5.7	Demonstrate array slicing	245
Exercise 5.8	Replace list operations by array computing	245
Exercise 5.9	Plot a formula	245
Exercise 5.10	Plot a formula for several parameters	245
Exercise 5.11	Specify the x and y axes in Exer. 5.10	245
Exercise 5.12	Plot exact and inexact Fahrenheit–Celsius formulas	246
Exercise 5.13	Plot the trajectory of a ball	246
Exercise 5.14	Implement Lagrange’s interpolation formula	246
Exercise 5.15	Plot the polynomial in Exer. 5.14	247
Exercise 5.16	Investigate the polynomial in Exer. 5.14	247
Exercise 5.17	Plot a wave packet	247
Exercise 5.18	Judge a plot	248
Exercise 5.19	Plot the viscosity of water	248
Exercise 5.20	Explore a complicated function graphically	248
Exercise 5.21	Plot Taylor polynomial approximations to $\sin x$	248
Exercise 5.22	Animate a wave packet	249
Exercise 5.23	Animate a smoothed Heaviside function	249
Exercise 5.24	Animate two-scale temperature variations	249
Exercise 5.25	Improve the solution in Exer. 5.24	250
Exercise 5.26	Animate a sequence of approximations to π	250
Exercise 5.27	Animate a planet’s orbit	250
Exercise 5.28	Animate the evolution of Taylor polynomials	251
Exercise 5.29	Plot the velocity profile for pipeflow	252
Exercise 5.30	Plot the functions from Exer. 3.13	252
Exercise 5.31	Make a movie of the functions from Exer. 3.13	252
Exercise 5.32	Plot functions from the command line	253
Exercise 5.33	Improve the program from Exercise 5.32	253
Exercise 5.34	Demonstrate energy concepts from physics	253
Exercise 5.35	Plot a w-like function	254
Exercise 5.36	Plot a piecewise constant function	254
Exercise 5.37	Vectorize a piecewise constant function	254
Exercise 5.38	Visualize approximations in the Midpoint integration rule	254
Exercise 5.39	Visualize approximations in the Trapezoidal integration rule	254
Exercise 5.40	Experience overflow in a function	254
Exercise 5.41	Experience less overflow in a function	255
Exercise 5.42	Extend Exer. 5.5 to a rank 2 array	256

Exercise 5.43	Explain why array computations fail	256
Exercise 6.1	Read a two-column data file	329
Exercise 6.2	Read a data file	329
Exercise 6.3	Simplify the implementation of Exer. 6.1	329
Exercise 6.4	Fit a polynomial to data	329
Exercise 6.5	Read acceleration data and find velocities	330
Exercise 6.6	Read acceleration data and plot velocities	331
Exercise 6.7	Find velocity from GPS coordinates	331
Exercise 6.8	Make a dictionary from a table	331
Exercise 6.9	Explore syntax differences: lists vs. dictionaries	332
Exercise 6.10	Improve the program from Ch. 6.2.5	332
Exercise 6.11	Interpret output from a program	332
Exercise 6.12	Make a dictionary	333
Exercise 6.13	Make a nested dictionary	333
Exercise 6.14	Make a nested dictionary from a file	333
Exercise 6.15	Compute the area of a triangle	333
Exercise 6.16	Compare data structures for polynomials	333
Exercise 6.17	Compute the derivative of a polynomial	333
Exercise 6.18	Generalize the program from Ch. 6.2.7	334
Exercise 6.19	Write function data to file	334
Exercise 6.20	Specify functions on the command line	334
Exercise 6.21	Interpret function specifications	335
Exercise 6.22	Compare average temperatures in cities	336
Exercise 6.23	Try Word or OpenOffice to write a program	336
Exercise 6.24	Evaluate objects in a boolean context	337
Exercise 6.25	Fit a polynomial to experimental data	337
Exercise 6.26	Generate an HTML report with figures	337
Exercise 6.27	Extract information from a weather page	338
Exercise 6.28	Compare alternative weather forecasts	338
Exercise 6.29	Improve the output in Exercise 6.28	338
Exercise 6.30	Allow different types for a function argument	338
Exercise 6.31	Make a function more robust	339
Exercise 6.32	Find proportion of bases inside/outside exons	339
Exercise 7.1	Make a function class	395
Exercise 7.2	Extend the class from Ch. 7.2.1	395
Exercise 7.3	Make classes for a rectangle and a triangle	395
Exercise 7.4	Make a class for straight lines	395
Exercise 7.5	Improve the constructor in Exer. 7.4	396
Exercise 7.6	Make a class for quadratic functions	396
Exercise 7.7	Make a class for linear springs	396
Exercise 7.8	Wrap functions in a class	397
Exercise 7.9	Extend the constructor in Exer. 7.8	397
Exercise 7.10	Deduce a class implementation	398
Exercise 7.11	Use special methods in Exer. 7.1	398
Exercise 7.12	Extend the class from Ch. 7.2.1	398

Exercise 7.13	Implement a class for numerical differentiation . . .	398
Exercise 7.14	Verify a program	399
Exercise 7.15	Test methods for numerical differentiation	399
Exercise 7.16	Modify a class for numerical differentiation	400
Exercise 7.17	Make a class for summation of series	400
Exercise 7.18	Apply the differentiation class from Ch. 7.3.2	401
Exercise 7.19	Make a class for the Heaviside function	401
Exercise 7.20	Add vectorization to the class in Exer. 7.19	401
Exercise 7.21	Equip the class in Exer. 7.19 with plotting	401
Exercise 7.22	Make a class for the indicator function	402
Exercise 7.23	Make a class for piecewise constant functions	402
Exercise 7.24	Extend the class in Exer. 7.23 with plot functionality	402
Exercise 7.25	Make a module for piecewise constant functions	402
Exercise 7.26	Use classes for computing inverse functions	403
Exercise 7.27	Vectorize a class for numerical integration	403
Exercise 7.28	Speed up repeated integral calculations	404
Exercise 7.29	Apply a polynomial class	404
Exercise 7.30	Find a bug in a class for polynomials	404
Exercise 7.31	Implement subtraction of polynomials	405
Exercise 7.32	Represent a polynomial by a NumPy array	405
Exercise 7.33	Vectorize a class for polynomials	405
Exercise 7.34	Use a dict to hold polynomial coefficients; add	405
Exercise 7.35	Use a dict to hold polynomial coefficients; mul	406
Exercise 7.36	Extend class Vec2D to work with lists/tuples	406
Exercise 7.37	Extend class Vec2D to 3D vectors	406
Exercise 7.38	Use NumPy arrays in class Vec2D	406
Exercise 7.39	Use classes in the program from Ch. 6.7.2	407
Exercise 7.40	Use a class in Exer. A.25	407
Exercise 7.41	Apply the class from Exer. 7.40 interactively	408
Exercise 7.42	Find local and global extrema of a function	408
Exercise 7.43	Improve the accuracy in Exer. 7.42	410
Exercise 7.44	Find the optimal production for a company	410
Exercise 7.45	Extend the program from Exer. 7.44	412
Exercise 8.1	Flip a coin N times	466
Exercise 8.2	Compute a probability	466
Exercise 8.3	Choose random colors	466
Exercise 8.4	Draw balls from a hat	466
Exercise 8.5	Computing probabilities of rolling dice	466
Exercise 8.6	Estimate the probability in a dice game	466
Exercise 8.7	Compute the probability of hands of cards	467
Exercise 8.8	Decide if a dice game is fair	467
Exercise 8.9	Adjust the game in Exer. 8.8	467
Exercise 8.10	Generalize the game from Chap. 8.3.2	467
Exercise 8.11	Compare two playing strategies	467

Exercise 8.12	Solve Exercise 8.11 with different no. of dice	468
Exercise 8.13	Extend Exercise 8.12	468
Exercise 8.14	Investigate the winning chances of some games . . .	468
Exercise 8.15	Compute probabilities of throwing two dice	468
Exercise 8.16	Play with vectorized boolean expressions	468
Exercise 8.17	Vectorize the program from Exer. 8.1	469
Exercise 8.18	Vectorize the code in Exer. 8.2	469
Exercise 8.19	Throw dice and compute a small probability	469
Exercise 8.20	Difference equation for random numbers	469
Exercise 8.21	Make a class for drawing balls from a hat	470
Exercise 8.22	Independent vs. dependent random numbers	470
Exercise 8.23	Compute the probability of flipping a coin	470
Exercise 8.24	Extend Exer. 8.23	471
Exercise 8.25	Simulate the problems in Exer. 4.25	471
Exercise 8.26	Simulate a poker game	471
Exercise 8.27	Write a non-vectorized version of a code	471
Exercise 8.28	Estimate growth in a simulation model	472
Exercise 8.29	Investigate guessing strategies for Ch. 8.4.1	472
Exercise 8.30	Make a vectorized solution to Exer. 8.8	472
Exercise 8.31	Compute π by a Monte Carlo method	472
Exercise 8.32	Implement a variant of Exer. 8.31	473
Exercise 8.33	Compute π by a random sum	473
Exercise 8.34	1D random walk with drift	473
Exercise 8.35	1D random walk until a point is hit	473
Exercise 8.36	Simulate making a fortune from gaming	473
Exercise 8.37	Make a class for 2D random walk	474
Exercise 8.38	Vectorize the class code from Exer. 8.37	474
Exercise 8.39	2D random walk with walls; scalar version	475
Exercise 8.40	2D random walk with walls; vectorized version . . .	475
Exercise 8.41	Simulate the mixture of gas molecules	475
Exercise 8.42	Solve a variant of Exer. 8.41	475
Exercise 8.43	Guess beer brands	476
Exercise 8.44	Simulate stock prices	476
Exercise 8.45	Compute with option prices in finance	476
Exercise 8.46	Compute velocity and acceleration	478
Exercise 8.47	Differentiate noisy signals	478
Exercise 8.48	Model the noise in the data in Exer. 8.47	479
Exercise 8.49	Reduce the noise in Exer. 8.47	480
Exercise 8.50	Make a class for differentiating noisy data	480
Exercise 8.51	Speed up Markov chain mutation	481
Exercise 9.1	Demonstrate the magic of inheritance	548
Exercise 9.2	Inherit from classes in Ch. 9.1	549
Exercise 9.3	Inherit more from classes in Ch. 9.1	549
Exercise 9.4	Reverse the class hierarchy from Ch. 9.1	549
Exercise 9.5	Make circle a subclass of an ellipse	549

Exercise 9.6	Make super- and subclass for a point	550
Exercise 9.7	Modify a function class by subclassing	550
Exercise 9.8	Explore the accuracy of difference formulas	550
Exercise 9.9	Implement a subclass	551
Exercise 9.10	Make classes for numerical differentiation	551
Exercise 9.11	Implement a new subclass for differentiation	551
Exercise 9.12	Understand if a class can be used recursively	551
Exercise 9.13	Represent people by a class hierarchy	551
Exercise 9.14	Add a new class in a class hierarchy	553
Exercise 9.15	Change the user interface of a class hierarchy	553
Exercise 9.16	Compute convergence rates of numerical integration methods	553
Exercise 9.17	Add common functionality in a class hierarchy	554
Exercise 9.18	Make a class hierarchy for root finding	554
Exercise 9.19	Make a calculus calculator class	555
Exercise 9.20	Extend Exer. 9.19	556
Exercise 9.21	Make line drawing of a person; program	556
Exercise 9.22	Make line drawing of a person; class	556
Exercise 9.23	Animate a person with waving hands	556
Exercise A.1	Determine the limit of a sequence	583
Exercise A.2	Determine the limit of a sequence	583
Exercise A.3	Experience convergence problems	583
Exercise A.4	Compute π via sequences	584
Exercise A.5	Reduce memory usage of difference equations	584
Exercise A.6	Compute the development of a loan	584
Exercise A.7	Solve a system of difference equations	584
Exercise A.8	Extend the model (A.32)–(A.33)	584
Exercise A.9	Experiment with the program from Exer. A.8	585
Exercise A.10	Change index in a difference equation	585
Exercise A.11	Construct time points from dates	585
Exercise A.12	Solve nonlinear equations by Newton’s method	586
Exercise A.13	Visualize the convergence of Newton’s method	586
Exercise A.14	Implement the Secant method	587
Exercise A.15	Test different methods for root finding	587
Exercise A.16	Make difference equations for the Midpoint rule	587
Exercise A.17	Compute the arc length of a curve	587
Exercise A.18	Find difference equations for computing $\sin x$	588
Exercise A.19	Find difference equations for computing $\cos x$	588
Exercise A.20	Make a guitar-like sound	588
Exercise A.21	Damp the bass in a sound file	589
Exercise A.22	Damp the treble in a sound file	589
Exercise A.23	Demonstrate oscillatory solutions of (A.13)	590
Exercise A.24	Improve the program from Exer. A.23	590
Exercise A.25	Generate an HTML report	591
Exercise A.26	Simulate the price of wheat	591

Exercise B.1	Interpolate a discrete function	619
Exercise B.2	Study a function for different parameter values . .	619
Exercise B.3	Study a function and its derivative	620
Exercise B.4	Use the Trapezoidal method	620
Exercise B.5	Compute a sequence of integrals	621
Exercise B.6	Use the Trapezoidal method	621
Exercise B.7	Compute trigonometric integrals	622
Exercise B.8	Plot functions and their derivatives	623
Exercise B.9	Use the Trapezoidal method	623
Exercise C.1	Solve a nonhomogeneous linear ODE	639
Exercise C.2	Solve a nonlinear ODE	639
Exercise C.3	Solve an ODE for $y(x)$	639
Exercise C.4	Experience instability of an ODE	640
Exercise C.5	Solve an ODE with time-varying growth	640
Exercise D.1	Use a w function with a step	665
Exercise D.2	Make a callback function in Exercise D.1	665
Exercise D.3	Improve input to the simulation program	665
Exercise E.1	Solve a simple ODE in two ways	705
Exercise E.2	Use the ODESolver hierarchy to solve a simple ODE	705
Exercise E.3	Solve an ODE for emptying a tank	705
Exercise E.4	Scale the logistic equation	706
Exercise E.5	Compute logistic growth with time-varying carrying capacity	707
Exercise E.6	Solve an ODE for the arc length	707
Exercise E.7	Compute inverse functions by solving an ODE . . .	707
Exercise E.8	Generalize the implementation in Exer. E.7	708
Exercise E.9	Extend the implementation in Exer. E.8	708
Exercise E.10	Compute inverse functions by interpolation	709
Exercise E.11	Simulate a falling or rising body in a fluid	709
Exercise E.12	Check the solution's limit in Exer. E.11	711
Exercise E.13	Visualize the different forces in Exer. E.11	711
Exercise E.14	Solve an ODE until constant solution	711
Exercise E.15	Use classes in Exer. E.14	712
Exercise E.16	Scale away parameters in Exer. E.14	712
Exercise E.17	Use the 4th-order Runge-Kutta on (C.34)	713
Exercise E.18	Compare ODE methods	713
Exercise E.19	Compare ODE methods	713
Exercise E.20	Solve two coupled ODEs for radioactive decay . . .	714
Exercise E.21	Code a 2nd-order Runge-Kutta method; function .	714
Exercise E.22	Code a 2nd-order Runge-Kutta method; class . . .	714
Exercise E.23	Make a subclass for Heun's method	714
Exercise E.24	Make a subclass for the Midpoint method	715
Exercise E.25	Make a subclass for an Adams-Bashforth method	715
Exercise E.26	Implement the iterated Midpoint method; function	715

Exercise E.27	Implement the iterated Midpoint method; class . .	715
Exercise E.28	Make a subclass for the iterated Midpoint method	716
Exercise E.29	Study convergence of numerical methods for ODEs	716
Exercise E.30	Solve an ODE specified on the command line	716
Exercise E.31	Find the body's position in Exer. E.11	717
Exercise E.32	Add the effect of air resistance on a ball	717
Exercise E.33	Solve an ODE system for an electric circuit	718
Exercise E.34	Compare methods for solving (E.76)–(E.77)	718
Exercise E.35	Simulate the spreading of a disease	718
Exercise E.36	Make a more flexible code in Exer. E.35	720
Exercise E.37	Introduce vaccination in Exer. E.35	721
Exercise E.38	Introduce a vaccination campaign in Exer. E.37 . .	721
Exercise E.39	Find optimal vaccination period in Exer. E.38 . . .	721
Exercise E.40	Simulate human–zombie interaction	722
Exercise E.41	Simulate an entire zombie movie	724
Exercise E.42	Simulate a war on zombies	725
Exercise E.43	Explore predator-prey population interactions . . .	725
Exercise E.44	Formulate a 2nd-order ODE as a system	726
Exercise E.45	Solve the system in Exer. E.44 in a special case . .	727
Exercise E.46	Make a tool for analyzing oscillatory solutions . . .	728
Exercise E.47	Enhance the code from Exer. E.45	729
Exercise E.48	Allow flexible choice of functions in Exer. E.47 . . .	732
Exercise E.49	Use the modules from Exer. E.47 and E.48	733
Exercise E.50	Model the economy of fishing	734

Our first examples on computer programming involve programs that evaluate mathematical formulas. You will learn how to write and run a Python program, how to work with variables, how to compute with mathematical functions such as e^x and $\sin x$, and how to use Python for interactive calculations.

We assume that you are somewhat familiar with computers so that you know what files and folders¹ are, how you move between folders, how you change file and folder names, and how you write text and save it in a file.

All the program examples associated with this chapter can be found as files in the folder `src/formulas`. We refer to the preface for how to download the folder tree `src` containing all the program files for this book.

1.1 The First Programming Encounter: A Formula

The first formula we shall consider concerns the vertical motion of a ball thrown up in the air. From Newton's second law of motion one can set up a mathematical model for the motion of the ball and find that the vertical position of the ball, called y , varies with time t according to the following formula²:

$$y(t) = v_0 t - \frac{1}{2} g t^2. \quad (1.1)$$

¹ Another frequent word for folder is directory.

² This formula neglects air resistance, which is usually small unless v_0 is large – see Exercise 1.11.

Here, v_0 is the initial velocity of the ball, g is the acceleration of gravity, and t is time. Observe that the y axis is chosen such that the ball starts at $y = 0$ when $t = 0$.

To get an overview of the time it takes for the ball to move upwards and return to $y = 0$ again, we can look for solutions to the equation $y = 0$:

$$v_0 t - \frac{1}{2} g t^2 = t \left(v_0 - \frac{1}{2} g t \right) = 0 \quad \Rightarrow \quad t = 0 \text{ or } t = 2v_0/g.$$

That is, the ball returns after $2v_0/g$ seconds, and it is therefore reasonable to restrict the interest of (1.1) to $t \in [0, 2v_0/g]$.

1.1.1 Using a Program as a Calculator

Our first program will evaluate (1.1) for a specific choice of v_0 , g , and t . Choosing $v_0 = 5$ m/s and $g = 9.81$ m/s² makes the ball come back after $t = 2v_0/g \approx 1$ s. This means that we are basically interested in the time interval $[0, 1]$. Say we want to compute the height of the ball at time $t = 0.6$ s. From (1.1) we have

$$y = 5 \cdot 0.6 - \frac{1}{2} \cdot 9.81 \cdot 0.6^2$$

This arithmetic expression can be evaluated and its value can be printed by a very simple one-line Python program:

```
print 5*0.6 - 0.5*9.81*0.6**2
```

The four standard arithmetic operators are written as $+$, $-$, $*$, and $/$ in Python and most other computer languages. The exponentiation employs a double asterisk notation in Python, e.g., 0.6^2 is written as $0.6**2$.

Our task now is to create the program and run it, and this will be described next.

1.1.2 About Programs and Programming

A computer program is just a sequence of instructions to the computer, written in a computer language. Most computer languages look somewhat similar to English, but they are very much simpler. The number of words and associated instructions is very limited, so to perform a complicated operation we must combine a large number of different types of instructions. The program text, containing the sequence of instructions, is stored in one or more files. The computer can only do exactly what the program tells the computer to do.

Another perception of the word “program” is a file that can be run (“double-clicked”) to perform a task. Sometimes this is a file with textual instructions (which is the case with Python), and sometimes this file is a translation of all the program text to a more efficient and computer-friendly language that is quite difficult to read for a human. All the programs in this chapter consist of short text stored in a single file. Other programs that you have used frequently, for instance Firefox or Internet Explorer for reading web pages, consist of program text distributed over a large number of files, written by a large number of people over many years. One single file contains the machine-efficient translation of the whole program, and this is normally the file that you “double-click” on when starting the program. In general, the word “program” means either this single file or the collection of files with textual instructions.

Programming is obviously about writing programs, but this process is more than writing the correct instructions in a file. First, we must understand how a problem can be solved by giving a sequence of instructions to the computer. This is usually the most difficult thing with programming. Second, we must express this sequence of instructions correctly in a computer language and store the corresponding text in a file (the program). Third, we must run the program, check the validity of the results, and usually enter a fourth phase where errors in the program must be found and corrected. Mastering this process requires a lot of training, which implies making a large number of programs (exercises in this book, for instance) and getting the programs to work.

1.1.3 Tools for Writing Programs

Since programs consist of plain text, we need to write this text with the help of another program that can store the text in a file. You have most likely extensive experience with writing text on a computer, but for writing your own programs you need special programs, called *editors*, which preserve exactly the characters you type. The widespread word processors, Microsoft Word being a primary example³, are aimed at producing nice-looking reports. These programs *format* the text and are *not* good tools for writing your own programs, even though they can save the document in a pure text format. Spaces are often important in Python programs, and *editors* for plain text give you complete control of the spaces and all other characters in the program file.

³ Other examples are OpenOffice, TextEdit, iWork Pages, and BBEdit. Chapter 6.1.3 gives some insight into why such programs are not suitable for writing your own Python programs.

Emacs, XEmacs, Vim, and Gedit are popular editors for writing programs on Linux or Unix systems, including Mac⁴ computers. On Windows we recommend Notepad++ or the Windows versions of Emacs, Vim, or Gedit. None of these programs are part of a standard Windows installation.

A special editor for Python programs comes with the Python software. This editor is called Idle and is usually installed under the name `idle` (or `idle-python`) on Linux/Unix and Mac. On Windows, it is reachable from the Python entry in the Start menu. Idle has a gentle learning curve, but is mainly restricted to writing Python programs. Completely general editors, such as Emacs and Vim, have a steeper learning curve and can be used for any text files, including reports in student projects.

More advanced development environments also exist for Python. For numerical programming the Spyder software is of particular interest as it provides a graphical environment much like that of Matlab.

1.1.4 Using Idle to Write the Program

Let us explain in detail how we can use Idle to write our one-line program from Chapter 1.1.1. Idle may not become your favorite editor for writing Python programs, yet we recommend to follow the steps below to get in touch with Idle and try it out. You can simply replace the Idle instructions by similar actions in your favorite editor, Emacs for instance.

First, create a folder where your Python programs can be located. Here we choose a folder name `mytest` under your home folder. To write and run Python programs, you will need a *terminal* window on Linux/Unix or Mac, sometimes called a *console* window, or an MS-DOS window or *command prompt* on Windows. Launch such a window and use the `cd` (change directory) command to move to the `mytest` folder. If you have not made the folder with a graphical file & folder manager you must create the folder by the command `mkdir mytest` (`mkdir` stands for make directory).

The next step is to start Idle. This can be done by writing `idle&` (Linux) or `start idle` (Windows) in the terminal window. Alternatively, you can launch Idle from the Start menu on Windows. Figure 1.1 displays a terminal window where we create the folder, move to the folder, and start Idle⁵.

⁴ On Mac, you may want to download a more “Mac-like” editor such as the Really Simple Text program.

⁵ The ampersand after `idle` is Linux specific. On Windows you have to write `start idle` instead. The ampersand postfix or the `start` prefix makes it possible to continue with other commands in the terminal window while the program, here Idle, is running. This is important for program testing where we often do a lot of edit-and-run cycles, which means that we frequently switch between the editor and the terminal window.

```
Terminal> mkdir mytest
Terminal> cd mytest
Terminal> idle&
[1] 12148
Terminal> █
```

Fig. 1.1 A terminal window on a Linux/Unix/Mac machine where we create a folder (`mkdir`), move to the folder (`cd`), and start Idle.

If a window now appears on the screen, with “Python Shell” in the title bar of the window, go to its File menu and choose New Window. The window that now pops up is the Idle editor (having the window name “Untitled”). Move the cursor inside this window and write the line

```
print 5*0.6 - 0.5*9.81*0.6**2
```

followed by pressing the Return key. The Idle window looks as in Figure 1.2.

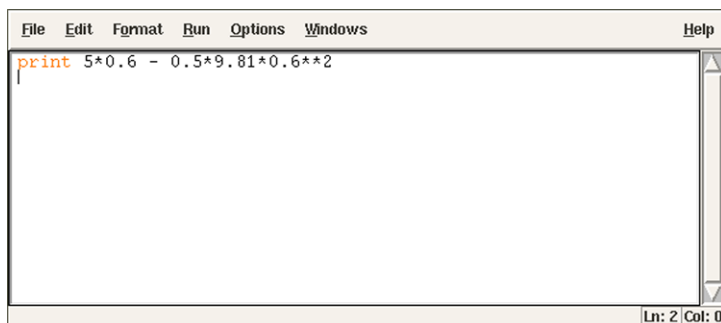

Fig. 1.2 An Idle editor window containing our first one-line program.

Your program is now in the Idle editor, but before you can run it, the program text must be saved in a file. Choose File and then Save As. As usual, such a command launches a new window where you can fill in the name of the file where the program is to be stored. And as always, you must first check that you are in the right folder, or directory which is Idle’s word for the same thing. The upper line in the file dialog window contains the folder name. Clicking on the bar to the right (after the directory/folder name), gives a possibility to move upwards in the folder hierarchy, and clicking on the folder icon to the right of the bar, moves just one folder upwards. To go down in the

folder tree, you simply double-click a folder icon in the main window of this dialog. You must now navigate to the `mytest` folder under your home folder. If you started Idle from the terminal window, there is no need to navigate and change folder. Simply fill in the name of the program. Any name will do, but we suggest that you choose the name `ball1.py` because this name is compatible with what we use later in this book. The file extension `.py` is common for Python programs, but not strictly required⁶.

Press the Save button and move back to the terminal window. Make sure you have a new file `ball1.py` here, by running the command `ls` (on Linux/Unix and Mac) or `dir` (on Windows). The output should be a text containing the name of the program file. You can now jump to the paragraph “How to Run the Program”, but it might be a good idea to read the warning below first.

Warning About Typing Program Text. Even though a program is just a text, there is one major difference between a text in a program and a text intended to be read by a human. When a human reads a text, she or he is able to understand the message of the text even if the text is not perfectly precise or if there are grammar errors. If our one-line program was expressed as

```
write 5*0.6 - 0.5*9.81*0.6^2
```

most humans would interpret `write` and `print` as the same thing, and many would also interpret `6^2` as 6^2 . In the Python language, however, `write` is a grammar error and `6^2` means an operation very different from the exponentiation `6**2`. Our communication with a computer through a program must be perfectly precise without a single grammar error⁷. The computer will only do exactly what we tell it to do. Any error in the program, however small, may affect the program. There is a chance that we will never notice it, but most often an error causes the program to stop or produce wrong results. The conclusion is that computers have a much more pedantic attitude to language than what (most) humans have.

Now you understand why any program text must be carefully typed, paying attention to the correctness of every character. If you try out program texts from this book, make sure that you type them in *exactly as you see them* in the book. Blanks, for instance, are often important in Python, so it is a good habit to always count them and type them in correctly. Any attempt not to follow this advice will cause you frustrations, sweat, and maybe even tears.

⁶ Some editors, like Emacs, have many features that make it easier to write Python programs, but these features will not be automatically available unless the program file has a `.py` extension.

⁷ “Programming demands significantly higher standard of accuracy. Things don’t simply have to make sense to another human being, they must make sense to a computer.” – Donald Knuth [4, p. 18], computer scientist, 1938–.

1.1.5 How to Run the Program

The one-line program above is stored in a file with name `ball1.py`. To run the program, you need to be in a terminal window and in the folder where the `ball1.py` file resides. The program is run by writing the command `python ball1.py` in the terminal window⁸:

```
Terminal
```

```
Terminal> python ball1.py
1.2342
```

The program immediately responds with printing the result of its calculation, and the output appears on the next line in the terminal window. Figure 1.3 shows what the whole terminal window may look like after having run the program.

We use the prompt `Terminal>` in this book to indicate commands in a Linux, Unix, Mac, or DOS terminal window. The text following the `Terminal>` prompt must be a valid Unix or DOS command. You will likely see a different prompt in the terminal window on your machine, perhaps something reflecting your username or the current folder.

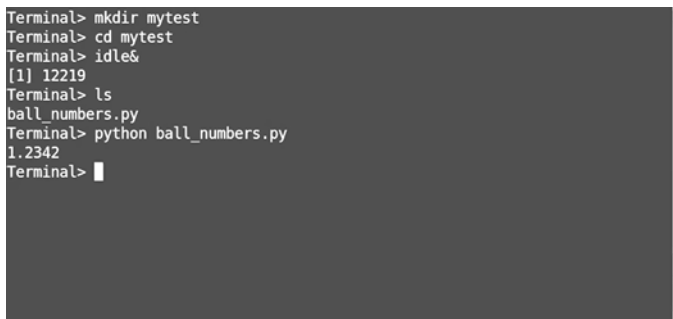

```
Terminal> mkdir mytest
Terminal> cd mytest
Terminal> idle&
[1] 12219
Terminal> ls
ball_numbers.py
Terminal> python ball_numbers.py
1.2342
Terminal> █
```

Fig. 1.3 A terminal window on a Linux/Unix/Mac machine where we run our first one-line Python program.

From your previous experience with computers you are probably used to double-click on icons to run programs. Python programs can also be run that way, but programmers usually find it more convenient to run programs by typing commands in a terminal window. Why this is so will be evident later when you have more programming experience. For now, simply accept that you are going to be a programmer, and that commands in a terminal window is an efficient way to work with the computer.

Suppose you want to evaluate (1.1) for $v_0 = 1$ and $t = 0.1$. This is easy: move the cursor to the Idle editor window, edit the program text to

⁸ There are other ways of running Python programs, as explained in Appendix H.1.

```
print 1*0.1 - 0.5*9.81*0.1**2
```

Save the file, move back to the terminal window and run the program as before:

```
Terminal  
Terminal> python ball1.py  
0.05095
```

We see that the result of the calculation has changed, as expected.

1.1.6 Verifying the Result

We should *always* carefully control that the output of a computer program is correct. You will experience that in most of the cases, at least until you are an experienced programmer, the output is wrong, and you have to search for errors. In the present application we can simply use a calculator to control the program. Setting $t = 0.6$ and $v_0 = 5$ in the formula, the calculator confirms that 1.2342 is the correct solution to our mathematical problem.

1.1.7 Using Variables

When we want to evaluate $y(t)$ for many values of t , we must modify the t value at two places in our program. Changing another parameter, like v_0 , is in principle straightforward, but in practice it is easy to modify the wrong number. Such modifications would be simpler to perform if we express our formula in terms of variables, i.e., symbols, rather than numerical values. Most programming languages, Python included, have variables similar to the concept of variables in mathematics. This means that we can define v_0 , g , t , and y as variables in the program, initialize the former three with numerical values, and combine these three variables to the desired right-hand side expression in (1.1), and assign the result to the variable y .

The alternative version of our program, where we use variables, may be written as this text:

```
v0 = 5  
g = 9.81  
t = 0.6  
y = v0*t - 0.5*g*t**2  
print y
```

Figure 1.4 displays what the program looks like in the Idle editor window. Variables in Python are defined by setting a name (here v_0 , g , t , or y) equal to a numerical value or an expression involving already defined variables.

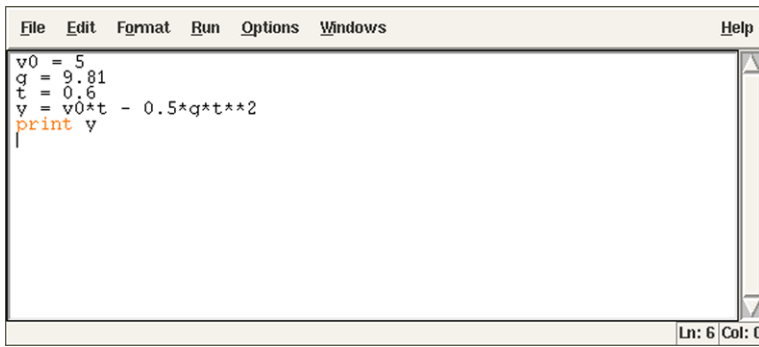

```

File Edit Format Run Options Windows Help
v0 = 5
g = 9.81
t = 0.6
y = v0*t - 0.5*g*t**2
print y
|
Ln: 6 Col: 0

```

Fig. 1.4 An Idle editor window containing a multi-line program with several variables.

Note that this second program is much easier to read because it is closer to the mathematical notation used in the formula (1.1). The program is also safer to modify, because we clearly see what each number is when there is a name associated with it. In particular, we can change t at one place only (the line $t = 0.6$) and not two as was required in the previous program.

We store the program text in a file `ball2.py`. Running the program,

```

Terminal
Terminal> python ball2.py

```

results in the correct output 1.2342.

1.1.8 Names of Variables

Introducing variables with descriptive names, close to those in the mathematical problem we are going to solve, is considered important for the readability and reliability (correctness) of the program. Variable names can contain any lower or upper case letter, the numbers from 0 to 9, and underscore, but the first character cannot be a number. Python distinguishes between upper and lower case, so X is always different from x . Here are a few examples on alternative variable names in the present example⁹:

```

initial_velocity = 5
acceleration_of_gravity = 9.81
TIME = 0.6
VerticalPositionOfBall = initial_velocity*TIME - \
    0.5*acceleration_of_gravity*TIME**2
print VerticalPositionOfBall

```

⁹ In this book we shall adopt the rule that variable names have lower case letters where words are separated by an underscore. The first two declared variables have this form.

With such long variables names, the code for evaluating the formula becomes so long that we have decided to break it into two lines. This is done by a backslash at the very end of the line (make sure there are no blanks after the backslash!).

We note that even if this latter version of the program contains variables that are defined precisely by their names, the program is harder to read than the one with variables `v0`, `g`, `t`, and `y0`.

The rule of thumb is to use the same variable names as those appearing in a precise mathematical description of the problem to be solved by the program. For all variables where there is no associated precise mathematical description and symbol, one must use *descriptive* variable names which explain the purpose of the variable. For example, if a problem description introduces the symbol D for a force due to air resistance, one applies a variable `D` also in the program. However, if the problem description does not define any symbol for this force, one must apply a descriptive name, such as `air_resistance`, `resistance_force`, or `drag_force`.

1.1.9 Reserved Words in Python

Certain words are reserved in Python because they are used to build up the Python language. These reserved words cannot be used as variable names: `and`, `as`, `assert`, `break`, `class`, `continue`, `def`, `del`, `elif`, `else`, `except`, `False`, `finally`, `for`, `from`, `global`, `if`, `import`, `in`, `is`, `lambda`, `None`, `nonlocal`, `not`, `or`, `pass`, `raise`, `return`, `True`, `try`, `with`, `while`, and `yield`. You may, for instance, add an underscore at the end to turn a reserved word into a variable name. See Exercise 1.16 for examples on legal and illegal variable names.

1.1.10 Comments

Along with the program statements it is often informative to provide some comments in a natural human language to explain the idea behind the statements. Comments in Python start with the `#` character, and everything after this character on a line is ignored when the program is run. Here is an example of our program with explanatory comments:

```
# Program for computing the height of a ball in vertical motion.
v0 = 5      # initial velocity
g = 9.81   # acceleration of gravity
t = 0.6    # time
y = v0*t - 0.5*g*t**2 # vertical position
print y
```

This program and the initial version on page 8 are identical when run on the computer, but for a human the latter is easier to understand because of the comments.

Good comments together with well-chosen variable names are necessary for any program longer than a few lines, because otherwise the program becomes difficult to understand, both for the programmer and others. It requires some practice to write really instructive comments. Never repeat with words what the program statements already clearly express. Use instead comments to provide important information that is not obvious from the code, for example, what mathematical variable names mean, what variables are used for, and general ideas that lie behind a forthcoming set of statements.

1.1.11 Formatting Text and Numbers

Instead of just printing the numerical value of y in our introductory program, we now want to write a more informative text, typically something like

```
At t=0.6 s, the height of the ball is 1.23 m.
```

where we also have control of the number of digits (here y is accurate up to centimeters only).

Printf Syntax. The output of the type shown above is accomplished by a `print` statement combined with some technique for formatting the numbers. The oldest and most widely used such technique is known as *printf* formatting¹⁰. For a newcomer to programming, the syntax of `printf` formatting may look awkward, but it is quite easy to learn and very convenient and flexible to work with. The `printf` syntax is used in a lot of other programming languages as well.

The sample output above is produced by this statement using `printf` syntax:

```
print 'At t=%g s, the height of the ball is %.2f m.' % (t, y)
```

Let us explain this line in detail. The `print` statement now prints a string: everything that is enclosed in quotes (either single: `'`, or double: `"`) denotes a string in Python. The string above is formatted using `printf` syntax. This means that the string has various “slots”, starting with a percentage sign, here `%g` and `%.2f`, where variables in the program can be put in. We have two “slots” in the present case, and consequently two variables must be put into the slots. The relevant syntax is to list the variables inside standard parentheses after the string, separated from the string by a percentage sign. The first variable, `t`, goes into the first “slot”. This “slot” has a format specification `%g`, where the percentage sign marks the slot and the following character,

¹⁰ This formatting was originally introduced by a function `printf` in the C programming language.

`g`, is a format specification. The `g` that a real number is to be written as compactly as possible. The next variable, `y`, goes into the second “slot”. The format specification here is `.2f`, which means a real number written with two digits after comma. The `f` in the `.2f` format stands for *float*, a short form for *floating-point number*, which is the term used for a real number on a computer.

For completeness we present the whole program, where text and numbers are mixed in the output:

```
v0 = 5
g = 9.81
t = 0.6
y = v0*t - 0.5*g*t**2
print 'At t=%g s, the height of the ball is %.2f m.' % (t, y)
```

You can find the program in the file `ball_print1.py` in the `src/formulas` folder.

There are many more ways to specify formats. For example, `e` writes a number in *scientific notation*, i.e., with a number between 1 and 10 followed by a power of 10, as in $1.2432 \cdot 10^{-3}$. On a computer such a number is written in the form `1.2432e-03`. Capital `E` in the exponent is also possible, just replace `e` by `E`, with the result `1.2432E-03`.

For *decimal notation* we use the letter `f`, as in `%f`, and the output number then appears with digits before and/or after a comma, e.g., `0.0012432` instead of `1.2432E-03`. With the `g` format, the output will use scientific notation for large or small numbers and decimal notation otherwise. This format is normally what gives most compact output of a real number. A lower case `g` leads to lower case `e` in scientific notation, while upper case `G` implies `E` instead of `e` in the exponent.

One can also specify the format as `10.4f` or `14.6E`, meaning in the first case that a float is written in decimal notation with four decimals in a field of width equal to 10 characters, and in the second case a float written in scientific notation with six decimals in a field of width 14 characters.

Here is a list of some important `printf` format specifications¹¹:

<code>%s</code>	a string
<code>%d</code>	an integer
<code>%0xd</code>	an integer padded with <code>x</code> leading zeros
<code>%f</code>	decimal notation with six decimals
<code>%e</code>	compact scientific notation, <code>e</code> in the exponent
<code>%E</code>	compact scientific notation, <code>E</code> in the exponent
<code>%g</code>	compact decimal or scientific notation (with <code>e</code>)
<code>%G</code>	compact decimal or scientific notation (with <code>E</code>)
<code>%xz</code>	format <code>z</code> right-adjusted in a field of width <code>x</code>
<code>%-xz</code>	format <code>z</code> left-adjusted in a field of width <code>x</code>
<code>%.yz</code>	format <code>z</code> with <code>y</code> decimals
<code>%x.yz</code>	format <code>z</code> with <code>y</code> decimals in a field of width <code>x</code>
<code>%%</code>	the percentage sign (<code>%</code>) itself

The program `printf_demo.py` exemplifies many of these formats.

¹¹ For a complete specification of the possible `printf`-style format strings, follow the link from the item “`printf`-style formatting” in the [index](#) of the Python Library Reference.

We may try out some formats by writing more numbers to the screen in our program (the corresponding file is `ball_print2.py`):

```
v0 = 5
g = 9.81
t = 0.6
y = v0*t - 0.5*g*t**2

print """
At t=%f s, a ball with
initial velocity v0=%.3E m/s
is located at the height %.2f m.
""" % (t, v0, y)
```

Observe here that we use a *triple-quoted* string, recognized by starting and ending with three single or double quotes: `'''` or `"""`. Triple-quoted strings are used for text that spans several lines.

In the `print` statement above, we print `t` in the `f` format, which by default implies six decimals; `v0` is written in the `.3E` format, which implies three decimals and the number spans as narrow field as possible; and `y` is written with two decimals in decimal notation in as narrow field as possible. The output becomes

Terminal

```
Terminal> python ball_print2.py

At t=0.600000 s, a ball with
initial velocity v0=5.000E+00 m/s
is located at the height 1.23 m.
```

You should look at each number in the output and check the formatting in detail.

Format String Syntax. Python offers all the functionality of the `printf` format and much more through a different syntax, often known as *format string syntax*. Let us illustrate this syntax on the one-line output previously used to show the `printf` construction. The corresponding format string syntax reads

```
print 'At t={t:g} s, the height of the ball is {y:.2f} m.'.format(
    t=t, y=y)
```

The “slots” where variables are inserted are now recognized by curly braces rather than a percentage sign. The name of the variable is listed with an optional colon and format specifier of the same kind as was used for the `printf` format. The various variables and their values must be listed at the end as shown. This time the “slots” have names so the sequence of variables is not important.

The multi-line example is written as follows in this alternative format:

```
print """
At t={t:f} s, a ball with
initial velocity v0={v0:.3E} m/s
is located at the height {y:.2f} m.
""".format(t=t, v0=v0, y=y)
```

The Newline Character. We often want a computer program to write out text that spans several lines. In the last example we obtained such output by triple-quoted strings. We could also use ordinary single-quoted strings and a special character for indicating where line breaks should occur. This special character reads `\n`, i.e., a backslash followed by the letter `n`. The two `print` statements

```
print """y(t) is
the position of
our ball."""
print 'y(t) is\nthe position of\nour ball'
```

result in identical output:

```
y(t) is
the position of
our ball.
```

1.2 Computer Science Glossary

It is now time to pick up some important words that programmers use when they talk about programming: algorithm, application, assignment, blanks (whitespace), bug, code, code segment, code snippet, debug, debugging, execute, executable, implement, implementation, input, library, operating system, output, statement, syntax, user, verify, and verification.

These words are frequently used in English in lots of contexts, yet they have a precise meaning in computer science.

Program and *code* are interchangeable terms. A code/program *segment* is a collection of consecutive statements from a program. Another term with similar meaning is *code snippet*. Many also use the word *application* in the same meaning as program and code. A related term is *source code*, which is the same as the text that constitutes the program. You find the source code of a program in one or more text files¹².

We talk about *running a program*, or equivalently *executing a program* or *executing a file*. The file we execute is the file in which the program text is stored. This file is often called an *executable* or an

¹² Note that text files normally have the extension `.txt`, while program files have an extension related to the programming language, e.g., `.py` for Python programs. The content of a `.py` file is, nevertheless, plain text as in a `.txt` file.

application. The program text may appear in many files, but the executable is just the single file that starts the whole program when we run that file. Running a file can be done in several ways, for instance, by double-clicking the file icon, by writing the filename in a terminal window, or by giving the filename to some program. This latter technique is what we have used so far in this book: we feed the filename to the program `python`. That is, we execute a Python program by executing another program `python`, which interprets the text in our Python program file.

The term *library* is widely used for a collection of generally useful program pieces that can be applied in many different contexts. Having access to good libraries means that you do not need to program code snippets that others have already programmed (most probable in a better way!). There are huge numbers of Python libraries. In Python terminology, the libraries are composed of *modules* and *packages*. Chapter 1.4 gives a first glimpse of the `math` module, which contains a set of standard mathematical functions for $\sin x$, $\cos x$, $\ln x$, e^x , $\sinh x$, $\sin^{-1} x$, etc. Later, you will meet many other useful modules. Packages are just collections of modules. The standard Python distribution comes with a large number of modules and packages, but you can download many more from the Internet, see in particular www.python.org/pypi. Very often, when you encounter a programming task that is likely to occur in many other contexts, you can find a Python module where the job is already done. To mention just one example, say you need to compute how many days there are between two dates. This is a non-trivial task that lots of other programmers must have faced, so it is not a big surprise that Python comes with a module `datetime` to do calculations with dates.

The recipe for what the computer is supposed to do in a program is called *algorithm*. In the examples in the first couple of chapters in this book, the algorithms are so simple that we can hardly distinguish them from the program text itself, but later in the book we will carefully set up an algorithm before attempting to *implement* it in a program. This is useful when the algorithm is much more compact than the resulting program code. The algorithm in the current example consists of three steps:

1. initialize the variables v_0 , g , and t with numerical values,
2. evaluate y according to the formula (1.1),
3. print the y value to the screen.

The Python program is very close to this text, but some less experienced programmers may want to write the tasks in English before translating them to Python.

The *implementation* of an algorithm is the process of writing and testing a program. The testing phase is also known as *verification*: After

the program text is written we need to *verify* that the program works correctly. This is a very important step that will receive substantial attention in the present book. Mathematical software produce numbers, and it is normally quite a challenging task to verify that the numbers are correct.

An *error* in a program is known as a *bug*¹³, and the process of locating and removing bugs is called *debugging*. Many look at debugging as the most difficult and challenging part of computer programming.

Programs are built of *statements*. There are many types of statements:

```
v0 = 3
```

is an *assignment* statement, while

```
print y
```

is a *print* statement. It is common to have one statement on each line, but it is possible to write multiple statements on one line if the statements are separated by semi-colon. Here is an example:

```
v0 = 3; g = 9.81; t = 0.6
y = v0*t - 0.5*g*t**2
print y
```

Although most newcomers to computer programming will think they understand the meaning of the lines in the above program, it is important to be aware of some major differences between notation in a computer program and notation in mathematics. When you see the equality sign “=” in mathematics, it has a certain interpretation as an equation ($x + 2 = 5$) or a definition ($f(x) = x^2 + 1$). In a computer program, however, the equality sign has a quite different meaning, and it is called an *assignment*. The right-hand side of an assignment contains an *expression*, which is a combination of values, variables, and operators. When the expression is *evaluated*, it results in a value that the variable on the left-hand side will refer to. We often say that the right-hand side value is *assigned* to the variable on the left-hand side. In the current context it means that we in the first line assign the number 3 to the variable `v0`, 9.81 to `g`, and 0.6 to `t`. In the next line, the right-hand side expression `v0*t - 0.5*g*t**2` is first evaluated, and the result is then assigned to the `y` variable.

¹³ In the very early days of computing, computers were built of a large number of tubes, which glowed and gave off heat. The heat attracted bugs, which caused short circuits. “Debugging” meant shutting down the computer and cleaning out the dead bugs.

Consider the assignment statement

```
y = y + 3
```

This statement is mathematically false, but in a program it just means that we evaluate the right-hand side expression and assign its value to the variable `y`. That is, we first take the current value of `y` and add 3. The value of this operation is assigned to `y`. The old value of `y` is then lost.

You may think of the `=` as an arrow, `y <- y+3`, rather than an equality sign, to illustrate that the value to the right of the arrow is stored in the variable to the left of the arrow¹⁴. An example will illustrate the principle of assignment to a variable:

```
y = 3
print y
y = y + 4
print y
y = y*y
print y
```

Running this program results in three numbers: 3, 7, 49. Go through the program and convince yourself that you understand what the result of each statement becomes.

A computer program must have correct *syntax*, meaning that the text in the program must follow the strict rules of the computer language for constructing statements. For example, the syntax of the print statement is the word `print`, followed by one or more spaces, followed by an expression of what we want to print (a Python variable, text enclosed in quotes, a number, for instance). Computers are very picky about syntax! For instance, a human having read all the previous pages may easily understand what this program does,

```
myvar = 5.2
printt Myvar
```

but the computer will find two errors in the last line: `printt` is an unknown instruction and `Myvar` is an undefined variable. Only the first error is reported (a syntax error), because Python stops the program once an error is found. All errors that Python finds are easy to remove. The difficulty with programming is to remove the rest of the errors, such as errors in formulas or the sequence of operations.

Blanks may or may not be important in Python programs. In Chapter 2.1.2 you will see that blanks are in some occasions essential for a correct program. Around `=` or arithmetic operators, however, blanks do not matter. We could hence write our program from Chapter 1.1.7 as

¹⁴ The R (or S or S-PLUS) programming languages for statistical computing actually use an arrow, while other languages such as Algol, Simula, and Pascal use `:=` to explicitly state that we are not dealing with a mathematical equality.

```
v0=3;g=9.81;t=0.6;y=v0*t-0.5*g*t**2;print y
```

This is not a good idea because blanks are essential for easy reading of a program code, and easy reading is essential for finding errors, and finding errors is *the* difficult part of programming. The recommended layout in Python programs specifies one blank around =, +, and -, and no blanks around *, /, and **. Note that the blank after print is essential: print is a command in Python and printy is not recognized as any valid command. (Python would look at printy as an undefined variable.) Computer scientists often use the term *whitespace* when referring to a blank¹⁵.

When we interact with computer programs, we usually provide some information to the program and get some information out. It is common to use the term *input data*, or just *input*, for the information that must be known beforehand. The result from a program is similarly referred to as *output data*, or just *output*. In our example, v_0 , g , and t constitute input, while y is output. All input data must be assigned values in the program before the output can be computed. Input data can be explicitly initialized in the program, as we do in the present example, or the data can be provided by user through keyboard typing while the program is running, as we explain in Chapter 4. Output data can be printed in the terminal window, as in the current example, displayed as graphics on the screen, as done in Chapter 5, or stored in a file for later access, as explained in Chapter 6.

The word *user* usually has a special meaning in computer science: It means a human interacting with a program. You are a user of a text editor for writing Python programs, and you are a user of your own programs. When you write programs, it is difficult to imagine how other users will interact with the program. Maybe they provide wrong input or misinterpret the output. Making user-friendly programs is very challenging and depends heavily on the target audience of users. The author had the average reader of the book in mind as a typical user when developing programs for this book.

A central part of a computer is the *operating system*. This is actually a collection of programs that manages the hardware and software resources on the computer. There are three major operating systems today: Windows, Macintosh (called Mac for short), and Unix. Several versions of Windows have appeared since the 1990s: Windows 95, 98, 2000, ME, XP, and Vista. Unix was invented already in 1970 and comes in many different versions. Nowadays, two open source implementations of Unix, Linux and Free BSD Unix, are most common. The latter forms the core of the Mac OS X operating system on Macintosh

¹⁵ More precisely, blank is the character produced by the space bar on the keyboard, while whitespace denotes any character(s) that, if printed, do not print ink on the paper: a blank, a tabulator character (produced by backslash followed by t), or a newline character (produced by backslash followed by n). The newline character is explained on page 14.

machines, while Linux exists in slightly different flavors: Red Hat, Debian, Ubuntu, and Suse to mention the most important distributions. We will use the term Unix in this book as a synonym for all the operating systems that inherit from classical Unix, such as Solaris, Free BSD, Mac OS X, and any Linux variant. Note that this use of Unix also includes Macintosh machines, but only newer machines as the older ones run an Apple-specific Mac operating system. As a computer user and reader of this book, you should know exactly which operating system you have. In particular, Mac users must know if their operating system is Unix-based or not.

The user's interaction with the operation system is through a set of programs. The most widely used of these enable viewing the contents of folders or starting other programs. To interact with the operating system, as a user, you can either issue commands in a terminal window or use graphical programs. For example, for viewing the file contents of a folder you can run the command `ls` in a Unix terminal window or `dir` in a DOS (Windows) terminal window. The graphical alternatives are many, some of the most common are Windows Explorer on Windows, Nautilus and Konqueror on Unix, and Finder on Mac. To start a program, it is common to double-click on a file icon or write the program's name in a terminal window.

1.3 Another Formula: Celsius-Fahrenheit Conversion

Our next example involves the formula for converting temperature measured in Celsius degrees to the corresponding value in Fahrenheit degrees:

$$F = \frac{9}{5}C + 32 \quad (1.2)$$

In this formula, C is the amount of degrees in Celsius, and F is the corresponding temperature measured in Fahrenheit. Our goal now is to write a computer program which can compute F from (1.2) when C is known.

1.3.1 Potential Error: Integer Division

Straightforward Coding of the Formula. A straightforward attempt at coding the formula (1.2) goes as follows¹⁶:

¹⁶ The parentheses around $9/5$ are not strictly needed, i.e., $(9/5)*C$ is computationally identical to $9/5*C$, but parentheses remove any doubt that $9/5*C$ could mean $9/(5*C)$. Chapter 1.3.4 has more information on this topic.

```
C = 21
F = (9/5)*C + 32
print F
```

When run, this program prints the value 53. You can find the program in the file `c2f_v1.py`¹⁷ in the `src/formulas` folder – as all other programs from this chapter.

Verifying the Results. Testing the correctness is easy in this case since we can evaluate the formula on a calculator: $\frac{9}{5} \cdot 21 + 32$ is 69.8, not 53. What is wrong? The formula in the program looks correct!

Float and Integer Division. The error in our program above is one of the most common errors in mathematical software and is not at all obvious for a newcomer to programming. In many computer languages, there are two types of divisions: float division and integer division. Float division is what you know from mathematics: $9/5$ becomes 1.8 in decimal notation.

Integer division a/b with integers (whole numbers) a and b results in an integer that is truncated (or mathematically, “rounded down”). More precisely, the result is the largest integer c such that $bc \leq a$. This implies that $9/5$ becomes 1 since $1 \cdot 5 = 5 \leq 9$ while $2 \cdot 5 = 10 > 9$. Another example is $1/5$, which becomes 0 since $0 \cdot 5 \leq 1$ (and $1 \cdot 5 > 1$). Yet another example is $16/6$, which results in 2 (try $2 \cdot 6$ and $3 \cdot 6$ to convince yourself). Many computer languages, including Fortran, C, C++, Java, and Python, interpret a division operation a/b as integer division if both operands a and b are integers. If either a or b is a real (floating-point) number, a/b implies the standard mathematical float division.

The problem with our program is the coding of the formula $(9/5)*C + 32$. This formula is evaluated as follows. First, $9/5$ is calculated. Since 9 and 5 are interpreted by Python as integers (whole numbers), $9/5$ is a division between two integers, and Python chooses by default integer division, which results in 1. Then 1 is multiplied by C , which equals 21, resulting in 21. Finally, 21 and 32 are added with 53 as result.

We shall very soon present a correct version of the temperature conversion program, but first it may be advantageous to introduce a frequently used word in Python programming: *object*.

1.3.2 Objects in Python

When we write

¹⁷ The `v1` part of the name stands for “version 1”. Throughout this book, we will often develop several trial versions of a program, but remove the version number in the final version of the program.

```
C = 21
```

Python interprets the number 21 on the right-hand side of the assignment as an integer and creates an `int` (for integer) *object* holding the value 21. The variable `C` acts as a *name* for this `int` object. Similarly, if we write `C = 21.0`, Python recognizes 21.0 as a real number and therefore creates a `float` (for floating-point) object holding the value 21.0 and lets `C` be a name for this object. In fact, any assignment statement has the form of a variable name on the left-hand side and an object on the right-hand side. One may say that Python programming is about solving a problem by defining and changing objects.

At this stage, you do not need to know what an object really is, just think of an `int` object as a collection, say a storage box, with some information about an integer number. This information is stored somewhere in the computer's memory, and with the name `C` the program gets access to this information. The fundamental issue right now is that 21 and 21.0 are identical numbers in mathematics, while in a Python program 21 gives rise to an `int` object and 21.0 to a `float` object.

There are lots of different object types in Python, and you will later learn how to create your own customized objects. Some objects contain a lot of data, not just an integer or a real number. For example, when we write

```
print 'A text with an integer %d and a float %f' % (2, 2.0)
```

a `str` (string) object, without a name, is first made of the text between the quotes and then this `str` object is printed. We can alternatively do this in two steps:

```
s = 'A text with an integer %d and a float %f' % (2, 2.0)
print s
```

1.3.3 Avoiding Integer Division

As a quite general rule of thumb, one should avoid integer division in mathematical formulas¹⁸. There are several ways to do this, as we describe in Appendix H.2. The simplest remedy in Python is to insert a statement that simply turns off integer division. A more widely applicable method, also in other programming languages than Python, is to enforce one of the operands to be a `float` object. In the current example, there are several ways to do this:

¹⁸ Some mathematical algorithms do make use of integer division, but in those cases you should use a double forward slash, `//`, as division operator, because this is Python's way of explicitly indicating integer division.

```
F = (9.0/5)*C + 32
F = (9/5.0)*C + 32
F = float(C)*9/5 + 32
```

In the first two lines, one of the operands is written as a decimal number, implying a `float` object and hence float division. In the last line, `float(C)*9` means `float` times `int`, which results in a `float` object, and float division is guaranteed.

A related construction,

```
F = float(C)*(9/5) + 32
```

does not work correctly, because `9/5` is evaluated by integer division, yielding 1, before being multiplied by a `float` representation of `C` (see next section for how compound arithmetic operations are calculated). In other words, the formula reads `F=C+32`, which is wrong.

We now understand why the first version of the program does not work and what the remedy is. A correct program is

```
C = 21
F = (9.0/5)*C + 32
print F
```

Instead of `9.0` we may just write `9`. (the dot implies a `float` interpretation of the number). The program is available in the file `c2f.py`. Try to run it – and observe that the output becomes `69.8`, which is correct.

Comment. We could easily have run into problems in our very first programs if we instead of writing the formula $\frac{1}{2}gt^2$ as `0.5*g*t**2` wrote `(1/2)*g*t**2`. Explain the problem!

1.3.4 Arithmetic Operators and Precedence

Formulas in Python programs are usually evaluated in the same way as we would evaluate them mathematically. Python proceeds from left to right, term by term in an expression (terms are separated by plus or minus). In each term, power operations such as a^b , coded as `a**b`, has precedence over multiplication and division. As in mathematics, we can use parentheses to dictate the way a formula is evaluated. Below are two illustrations of these principles.

- `5/9+2*a**4/2`: First `5/9` is evaluated (as integer division, giving 0 as result), then a^4 (`a**4`) is evaluated, then 2 is multiplied with a^4 , that result is divided by 2, and the answer is added to the result of the first term. The answer is therefore `a**4`.
- `5/(9+2)*a**(4/2)`: First $\frac{5}{9+2}$ is evaluated (as integer division, yielding 0), then `4/2` is computed (as integer division, yielding 2), then `a**2` is calculated, and that number is multiplied by the result of `5/(9+2)`. The answer is thus always zero.

As evident from these two examples, it is easy to unintentionally get integer division in formulas. Although integer division can be turned off in Python, we think it is important to be strongly aware of the integer division concept and to develop good programming habits to avoid it. The reason is that this concept appears in so many common computer languages that it is better to learn as early as possible how to deal with the problem rather than using a Python-specific feature to remove the problem.

1.4 Evaluating Standard Mathematical Functions

Mathematical formulas frequently involve functions such as \sin , \cos , \tan , \sinh , \cosh , \exp , \log , etc. On a pocket calculator you have special buttons for such functions. Similarly, in a program you also have ready-made functionality for evaluating these types of mathematical functions. One could in principle write one's own program for evaluating, e.g., the $\sin(x)$ function, but how to do this in an efficient way is a non-trivial topic. Experts have worked on this problem for decades and implemented their best recipes in pieces of software that we should reuse. This section tells you how to reach \sin , \cos , and similar functions in a Python context.

1.4.1 Example: Using the Square Root Function

Problem. Consider the vertical motion of a ball in (1.1) on page 1. We now ask the question: How long time does it take for the ball to reach the height y_c ? The answer is straightforward to derive. When $y = y_c$ we have

$$y_c = v_0 t - \frac{1}{2} g t^2.$$

We recognize that this equation is a quadratic equation which we must solve with respect to t . Rearranging,

$$\frac{1}{2} g t^2 - v_0 t + y_c = 0,$$

and using the well-known formula for the two solutions of a quadratic equation, we find

$$t_1 = \left(v_0 - \sqrt{v_0^2 - 2g y_c} \right) / g, \quad t_2 = \left(v_0 + \sqrt{v_0^2 - 2g y_c} \right) / g. \quad (1.3)$$

There are two solutions because the ball reaches the height y_c on its way up ($t = t_1$) and on its way down ($t = t_2 > t_1$).

The Program. To evaluate the expressions for t_1 and t_2 from (1.3) in a computer program, we need access to the square root function. In Python, the square root function and lots of other mathematical functions, such as `sin`, `cos`, `sinh`, `exp`, and `log`, are available in a module called `math`. We must first import the module before we can use it, that is, we must write `import math`. Thereafter, to take the square root of a variable `a`, we can write `math.sqrt(a)`. This is demonstrated in a program for computing t_1 and t_2 :

```
v0 = 5
g = 9.81
yc = 0.2
import math
t1 = (v0 - math.sqrt(v0**2 - 2*g*yc))/g
t2 = (v0 + math.sqrt(v0**2 - 2*g*yc))/g
print 'At t=%g s and %g s, the height is %g m.' % (t1, t2, yc)
```

The output from this program becomes

```
At t=0.0417064 s and 0.977662 s, the height is 0.2 m.
```

You can find the program as the file `ball_yc.py` in the `src/formulas` folder.

Two Ways of Importing a Module. The standard way to import a module, say `math`, is to write

```
import math
```

and then access individual functions in the module with the module name as prefix as in

```
x = math.sqrt(y)
```

People working with mathematical functions often find `math.sqrt(y)` less pleasing than just `sqrt(y)`. Fortunately, there is an alternative import syntax that allows us to skip the module name prefix. This alternative syntax has the form “from module import function”. A specific example is

```
from math import sqrt
```

Now we can work with `sqrt` directly, without the `math.` prefix. More than one function can be imported:

```
from math import sqrt, exp, log, sin
```

Sometimes one just writes

```
from math import *
```

to import all functions in the `math` module. This includes `sin`, `cos`, `tan`, `asin`, `acos`, `atan`, `sinh`, `cosh`, `tanh`, `exp`, `log` (base e), `log10` (base 10),

`sqrt`, as well as the famous numbers `e` and `pi`. Importing all functions from a module, using the asterisk (`*`) syntax, is convenient, but this may result in a lot of extra names in the program that are not used. It is in general recommended not to import more functions than those that are really used in the program¹⁹.

With a `from math import sqrt` statement we can write the formulas for the roots in a more pleasing way:

```
t1 = (v0 - sqrt(v0**2 - 2*g*yc))/g
t2 = (v0 + sqrt(v0**2 - 2*g*yc))/g
```

Import with New Names. Imported modules and functions can be given new names in the import statement, e.g.,

```
import math as m
# m is now the name of the math module
v = m.sin(m.pi)

from math import log as ln
v = ln(5)

from math import sin as s, cos as c, log as ln
v = s(x)*c(x) + ln(x)
```

In Python, everything is an object, and variables refer to objects, so new variables may refer to modules and functions as well as numbers and strings. The examples above on new names can also be coded by introducing new variables explicitly:

```
m = math
ln = m.log
s = m.sin
c = m.cos
```

1.4.2 Example: Using More Mathematical Functions

Our next examples involves calling some more mathematical functions from the `math` module. We look at the definition of the $\sinh(x)$ function:

$$\sinh(x) = \frac{1}{2}(e^x - e^{-x}). \quad (1.4)$$

We can evaluate $\sinh(x)$ in three ways: i) by calling `math.sinh`, ii) by computing the right-hand side of (1.4), using `math.exp`, or iii) by computing the right-hand side of (1.4) with the aid of the power expressions `math.e**x` and `math.e**(-x)`. A program doing these three alternative calculations is found in the file `3sinh.py`. The core of the program looks like this:

¹⁹ Nevertheless, of convenience we often use the `from module import *` syntax in this book.

```

from math import sinh, exp, e, pi
x = 2*pi
r1 = sinh(x)
r2 = 0.5*(exp(x) - exp(-x))
r3 = 0.5*(e**x - e**(-x))
print r1, r2, r3

```

The output from the program shows that all three computations give identical results:

```
267.744894041 267.744894041 267.744894041
```

1.4.3 A First Glimpse of Round-Off Errors

The previous example computes a function in three different yet mathematically equivalent ways, and the output from the `print` statement shows that the three resulting numbers are equal. Nevertheless, this is not the whole story. Let us try to print out `r1`, `r2`, `r3` with 16 decimals:

```
print '%.16f %.16f %.16f' % (r1,r2,r3)
```

This statement leads to the output

```
267.7448940410164369 267.7448940410164369 267.7448940410163232
```

Now `r1` and `r2` are equal, but `r3` is different! Why is this so?

Our program computes with real numbers, and real numbers need in general an infinite number of decimals to be represented exactly. The computer truncates the sequence of decimals because the storage is finite. In fact, it is quite standard to keep only 16 digits in a real number on a computer. Exactly how this truncation is done is not explained in this book²⁰. For now the purpose is to notify the reader that real numbers on a computer often have a small error. Only a few real numbers can be represented exactly with 16 digits, the rest of the real numbers are only approximations.

For this reason, most arithmetic operations involve inaccurate real numbers, resulting in inaccurate calculations. Think of the following two calculations: $1/49 \cdot 49$ and $1/51 \cdot 51$. Both expressions are identical to 1, but when we perform the calculations in Python,

```
print '%.16f %.16f' % (1/49.0*49, 1/51.0*51)
```

the result becomes

```
0.9999999999999999 1.0000000000000000
```

The reason why we do not get exactly 1.0 as answer in the first case, is because $1/49$ is not correctly represented in the computer. Also $1/51$ has an inexact representation, but the error does not propagate to the final answer.

²⁰ Instead, you can search for “floating point number” on wikipedia.org.

To summarize, errors²¹ in floating-point numbers may propagate through mathematical calculations and result in answers that are only approximations to the exact underlying mathematical values. The errors in the answers are commonly known as *round-off errors*. As soon as you use Python interactively as explained in the next section, you will encounter round-off errors quite often.

Python has a special module `decimal` which allows real numbers to be represented with adjustable accuracy so that round-off errors can be made as small as desired. However, we will hardly use this module²² because approximations implied by many mathematical methods applied throughout this book normally lead to (much) larger errors than those caused by round-off.

1.5 Interactive Computing

A particular convenient feature of Python is the ability to execute statements and evaluate expressions interactively. The environments where you work interactively with programming are commonly known as Python *shells*. The simplest Python shell is invoked by just typing `python` at the command line in a terminal window. Some messages about Python are written out together with a prompt `>>>`, after which you can issue commands. Let us try to use the interactive shell as a calculator. Type in `3*4.5-0.5` and then press the Return key to see Python's response to this expression:

```
Terminal> python
Python 2.5.1 (r251:54863, May 2 2007, 16:56:35)
[GCC 4.1.2 (Ubuntu 4.1.2-0ubuntu4)] on linux2
Type "help", "copyright", "credits" or "license" for more information.
>>> 3*4.5-0.5
13.0
```

The text on a line after `>>>` is what we write (shell input) and the text without the `>>>` prompt is the result that Python calculates (shell output). It is easy, as explained below, to recover previous input and edit the text. This editing feature makes it convenient to experiment with statements and expressions.

1.5.1 Using the Python Shell

The program from Chapter 1.1.7 can be typed in, line by line, in the interactive shell:

²¹ Exercise 2.23 on page 84 estimates the size of the errors.

²² See the last paragraph of Chapter 3.1.9 for an example.

```
>>> v0 = 5
>>> g = 9.81
>>> t = 0.6
>>> y = v0*t - 0.5*g*t**2
>>> print y
1.2342
```

We can now easily calculate an y value corresponding to another (say) v_0 value: hit the up arrow key²³ to recover previous statements, repeat pressing this key until the $v_0 = 5$ statement is displayed. You can then edit the line, say you edit the statement to

```
>>> v0 = 6
```

Press return to execute this statement. You can control the new value of v_0 by either typing just v_0 or `print v0`:

```
>>> v0
6
>>> print v0
6
```

The next step is to recompute y with this new v_0 value. Hit the up arrow key multiple times to recover the statement where y is assigned, press the Return key, and write y or `print y` to see the result of the computation:

```
>>> y = v0*t - 0.5*g*t**2
>>> y
1.8341999999999996
>>> print y
1.8342
```

The reason why we get two slightly different results is that typing just y prints out all the decimals that are stored in the computer (16), while `print y` writes out y with fewer decimals. As mentioned on page 26, computations on a computer often suffer from round-off errors. The present calculation is no exception. The correct answer is 1.8342, but round-off errors lead to a number that is incorrect in the 16th decimal. The error is here $4 \cdot 10^{-16}$.

1.5.2 Type Conversion

Often you can work with variables in Python without bothering about the type of objects these variables refer to. Nevertheless, we encountered a serious problem in Chapter 1.3.1 with integer division, which forced us to be careful about the types of objects in a calculation. The

²³ This key works only if Python was compiled with the Readline library. In case the key does not work, try the editing capabilities in another Python shell, for example, IPython (see Chapter 1.5.3).

interactive shell is very useful for exploring types. The following example illustrates the `type` function and how we can convert an object from one type to another.

First, we create an `int` object bound to the name `C` and check its type by calling `type(C)`:

```
>>> C = 21
>>> type(C)
<type 'int'>
```

We convert this `int` object to a corresponding `float` object:

```
>>> C = float(C) # type conversion
>>> type(C)
<type 'float'>
>>> C
21.0
```

In the statement `C = float(C)` we create a new object from the original object referred to by the name `C` and bind it to the same name `C`. That is, `C` refers to a different object after the statement than before. The original `int` with value 21 cannot be reached anymore (since we have no name for it) and will be automatically deleted by Python.

We may also do the reverse operation, i.e., convert a particular `float` object to a corresponding `int` object:

```
>>> C = 20.9
>>> type(C)
<type 'float'>
>>> D = int(C) # type conversion
>>> type(D)
<type 'int'>
>>> D
20 # decimals are truncated :-/
```

In general, one can convert a variable `v` to type `MyType` by writing `v=MyType(v)`, if it makes sense to do the conversion.

In the last input we tried to convert a `float` to an `int`, and this operation implied stripping off the decimals. Correct conversion according to mathematical rounding rules can be achieved with help of the `round` function:

```
>>> round(20.9)
21.0
>>> int(round(20.9))
21
```

1.5.3 IPython

There exist several improvements of the standard Python shell presented in the previous section. The author advocates the IPython shell as the preferred interactive shell. You will then need to have IPython

installed. Typing `ipython` in a terminal window starts the shell. The (default) prompt in IPython is not `>>>` but `In [X]:`, where `X` is the number of the present input command. The most widely used features of IPython are summarized below.

Running Programs. Python programs can be run from within the shell:

```
In [1]: run ball2.py
1.2342
```

This command requires that you have taken a `cd` to the folder where the `ball2.py` program is located and started IPython from there.

On Windows you may, as an alternative to starting IPython from a DOS window, double click on the IPython desktop icon or use the Start menu. In that case, you must move to the right folder where your program is located. This is done by the `os.chdir` (change directory) command. Typically, you write something like

```
In [1]: import os
In [2]: os.chdir(r'C:\Documents and Settings\me\My Documents\div')
In [3]: run ball2.py
```

if the `ball2.py` program is located in the folder `div` under `My Documents` of user `me`. Note the `r` before the quote in the string: it is required to let a backslash really mean the backslash character.

We recommend to run all your Python programs from the IPython shell. Especially when something goes wrong, IPython can help you to examine the state of variables so that you become quicker to locate bugs. In the rest of the book, we just write the program name and the output when we illustrate the execution of a program:

Terminal

```
ball2.py
1.2342
```

You then need to write `run` before the program name if you execute the program in IPython, or if you prefer to run the program from the Terminal command prompt in a terminal window, you need to write `python` prior to the program name. Appendix H.1 describes various other ways to run a Python program.

Quick Recovery of Previous Output. The results of the previous statements in an interactive IPython session are available in variables of the form `_iX` (underscore, `i`, and a number `X`), where `X` is 1 for the last statement, 2 for the second last statement, and so forth. Short forms are `_` for `_i1`, `__` for `_i2`, and `___` for `_i3`. The output from the `In [1]` input above is `1.2342`. We can now refer to this number by an underscore and, e.g., multiply it by 10:

```
In [2]: _*10
Out[2]: 12.341999999999999
```

Output from Python statements or expressions in IPython are preceded by `Out[X]` where `X` is the command number corresponding to the previous `In [X]` prompt. When programs are executed, as with the `run` command, or when operating system commands are run (as shown below), the output is from the operating system and then not preceded by any `Out[X]` label.

TAB Completion. Pressing the TAB key will complete an incompletely typed variable name. For example, after defining `my_long_variable_name = 4`, write just `my` at the `In [4]:` prompt below, and then hit the TAB key. You will experience that `my` is immediately expanded to `my_long_variable_name`. This automatic expansion feature is called TAB completion and can save you from quite some typing.

```
In [3]: my_long_variable_name = 4
In [4]: my_long_variable_name
Out[4]: 4
```

Recovering Previous Commands. You can “walk” through the command history by typing `Ctrl-p` or the up arrow for going backward or `Ctrl-n` or the down arrow for going forward. Any command you hit can be edited and re-executed. Also commands from previous sessions are stored in the command history.

Running Unix/Windows Commands. Operating system commands can be run from IPython. Below we run the three Unix commands `date`, `ls` (list files), and `mkdir` (make directory):

```
In [5]: date
Thu Nov 18 11:06:16 CET 2010

In [6]: ls
myfile.py yourprog.py

In [7]: mkdir mytestdir
```

If you have defined Python variables with the same name as operating system commands, e.g., `date=30`, you must write `!date` to run the corresponding operating system command.

IPython can do much more than what is shown here, but the advanced features and the documentation of them probably do not make sense before you are more experienced with Python – and with reading manuals.

Remark. In the rest of the book we will apply the `>>>` prompt in interactive sessions instead of the input and output prompts as used by

IPython, simply because most Python books and electronic manuals use `>>>` to mark input in interactive shells. However, when you sit by the computer and want to use an interactive shell, we recommend to use IPython, and then you will see the `In [X]` prompt instead of `>>>`.

1.6 Complex Numbers

Suppose $x^2 = 2$. Then most of us are able to find out that $x = \sqrt{2}$ is a solution to the equation. The more mathematically interested reader will also remark that $x = -\sqrt{2}$ is another solution. But faced with the equation $x^2 = -2$, very few are able to find a proper solution without any previous knowledge of *complex numbers*. Such numbers have many applications in science, and it is therefore important to be able to use such numbers in our programs.

On the following pages we extend the previous material on computing with real numbers to complex numbers. The text is optional, and readers without knowledge of complex numbers can safely drop this section and jump to Chapter 1.7.

A complex number is a pair of real numbers a and b , most often written as $a + bi$, or $a + ib$, where i is called the imaginary unit and acts as a label for the second term. Mathematically, $i = \sqrt{-1}$. An important feature of complex numbers is definitely the ability to compute square roots of negative numbers. For example, $\sqrt{-2} = \sqrt{2}i$ (i.e., $\sqrt{2}\sqrt{-1}$). The solutions of $x^2 = -2$ are thus $x_1 = +\sqrt{2}i$ and $x_2 = -\sqrt{2}i$.

There are rules for addition, subtraction, multiplication, and division between two complex numbers. There are also rules for raising a complex number to a real power, as well as rules for computing $\sin z$, $\cos z$, $\tan z$, e^z , $\ln z$, $\sinh z$, $\cosh z$, $\tanh z$, etc. for a complex number $z = a + ib$. We assume in the following that you are familiar with the mathematics of complex numbers, at least to the degree encountered in the program examples.

$$\text{let } u = a + bi \text{ and } v = c + di$$

$$u = v \quad \Rightarrow \quad a = c, \quad b = d$$

$$-u = -a - bi$$

$$u^* \equiv a - bi \quad (\text{complex conjugate})$$

$$u + v = (a + c) + (b + d)i$$

$$u - v = (a - c) + (b - d)i$$

$$uv = (ac - bd) + (bc + ad)i$$

$$u/v = \frac{ac + bd}{c^2 + d^2} + \frac{bc - ad}{c^2 + d^2}i$$

$$|u| = \sqrt{a^2 + b^2}$$

$$e^{iq} = \cos q + i \sin q$$

1.6.1 Complex Arithmetics in Python

Python supports computation with complex numbers. The imaginary unit is written as `j` in Python, instead of i as in mathematics. A complex number $2 - 3i$ is therefore expressed as `(2-3j)` in Python. We remark that the number i is written as `1j`, not just `j`. Below is a sample session involving definition of complex numbers and some simple arithmetics:

```
>>> u = 2.5 + 3j      # create a complex number
>>> v = 2            # this is an int
>>> w = u + v        # complex + int
>>> w
(4.5+3j)

>>> a = -2
>>> b = 0.5
>>> s = a + b*1j     # create a complex number from two floats
>>> s = complex(a, b) # alternative creation
>>> s
(-2+0.5j)
>>> s*w             # complex*complex
(-10.5-3.75j)
>>> s/w            # complex/complex
(-0.25641025641025639+0.28205128205128205j)
```

A complex object `s` has functionality for extracting the real and imaginary parts as well as computing the complex conjugate:

```
>>> s.real
-2.0
>>> s.imag
0.5
>>> s.conjugate()
(-2-0.5j)
```

1.6.2 Complex Functions in Python

Taking the sine of a complex number does not work:

```
>>> from math import sin
>>> r = sin(w)
Traceback (most recent call last):
  File "<input>", line 1, in ?
TypeError: can't convert complex to float; use abs(z)
```

The reason is that the `sin` function from the `math` module only works with real (`float`) arguments, not complex. A similar module, `cmath`, defines functions that take a complex number as argument and return a complex number as result. As an example of using the `cmath` module, we can demonstrate that the relation $\sin(ai) = i \sinh a$ holds:

```
>>> from cmath import sin, sinh
>>> r1 = sin(8j)
>>> r1
1490.4788257895502j
>>> r2 = 1j*sinh(8)
>>> r2
1490.4788257895502j
```

Another relation, $e^{iq} = \cos q + i \sin q$, is exemplified next:

```
>>> q = 8 # some arbitrary number
>>> exp(1j*q)
(-0.14550003380861354+0.98935824662338179j)
>>> cos(q) + 1j*sin(q)
(-0.14550003380861354+0.98935824662338179j)
```

1.6.3 Unified Treatment of Complex and Real Functions

The `cmath` functions always return complex numbers. It would be nice to have functions that return a `float` object if the result is a real number and a `complex` object if the result is a complex number. The Numerical Python package (see more about this package in Chapter 5) has such versions of the basic mathematical functions known from `math` and `cmath`. By taking a

```
from numpy.lib.scimath import *
```

one gets access to these flexible versions of mathematical functions²⁴. A session will illustrate what we obtain.

Let us first use the `sqrt` function in the `math` module:

```
>>> from math import sqrt
>>> sqrt(4) # float
2.0
>>> sqrt(-1) # illegal
Traceback (most recent call last):
  File "<input>", line 1, in ?
ValueError: math domain error
```

If we now import `sqrt` from `cmath`,

```
>>> from cmath import sqrt
```

the previous `sqrt` function is overwritten by the new one. More precisely, the name `sqrt` was previously bound to a function `sqrt` from the `math` module, but is now bound to another function `sqrt` from the `cmath` module. In this case, any square root results in a `complex` object:

```
>>> sqrt(4) # complex
(2+0j)
>>> sqrt(-1) # complex
1j
```

²⁴ The functions also come into play by a `from scipy import *` statement or `from scitools.std import *`. The latter is used as a standard import later in the book.

If we now take

```
>>> from numpy.lib.scimath import *
```

we import (among other things) a new `sqrt` function. This function is slower than the versions from `math` and `cmath`, but it has more flexibility since the returned object is `float` if that is mathematically possible, otherwise a `complex` is returned:

```
>>> sqrt(4)      # float
2.0
>>> sqrt(-1)    # complex
1j
```

As a further illustration of the need for flexible treatment of both complex and real numbers, we may code the formulas for the roots of a quadratic function $f(x) = ax^2 + bx + c$:

```
>>> a = 1; b = 2; c = 100 # polynomial coefficients
>>> from numpy.lib.scimath import sqrt
>>> r1 = (-b + sqrt(b**2 - 4*a*c))/(2*a)
>>> r2 = (-b - sqrt(b**2 - 4*a*c))/(2*a)
>>> r1
(-1+9.94987437107j)
>>> r2
(-1-9.94987437107j)
```

Using the up arrow, we may go back to the definitions of the coefficients and change them so the roots become real numbers:

```
>>> a = 1; b = 4; c = 1 # polynomial coefficients
```

Going back to the computations of `r1` and `r2` and performing them again, we get

```
>>> r1
-0.267949192431
>>> r2
-3.73205080757
```

That is, the two results are `float` objects. Had we applied `sqrt` from `cmath`, `r1` and `r2` would always be `complex` objects, while `sqrt` from the `math` module would not handle the first (complex) case.

1.7 Summary

1.7.1 Chapter Topics

Program Files. Python programs must be made by a pure text editor such as Emacs, Vim, Notepad++ or similar. The program text must be saved in a text file, with a name ending with the extension `.py`. The

filename can be chosen freely, but stay away from names that coincide with modules or keywords in Python, in particular do not use `math.py`, `time.py`, `random.py`, `os.py`, `sys.py`, `while.py`, `for.py`, `if.py`, `class.py`, `def.py`, to mention some forbidden filenames.

Programs Must Be Accurate! A program is a collection of statements stored in a text file. Statements can also be executed interactively in a Python shell. Any error in any statement may lead to termination of the execution or wrong results. The computer does exactly what the programmer tells the computer to do!

Variables. The statement

```
some_variable = obj
```

defines a variable with the name `some_variable` which refers to an object `obj`. Here `obj` may also represent an expression, say a formula, whose value is a Python object. For example, `1+2.5` involves the addition of an `int` object and a `float` object, resulting in a `float` object. Names of variables can contain upper and lower case English letters, underscores, and the digits from 0 to 9, but the name cannot start with a digit. Nor can a variable name be a reserved word in Python.

If there exists a precise mathematical description of the problem to be solved in a program, one should choose variable names that are in accordance with the mathematical description. Quantities that do not have a defined mathematical symbol, should be referred to by *descriptive* variable names, i.e., names that explain the variable's role in the program. Well-chosen variable names are essential for making a program easy to read, easy to debug, and easy to extend. Well-chosen variable names also reduce the need for comments.

Comment Lines. Everything after `#` on a line is ignored by Python and used to insert free running text, known as *comments*. The purpose of comments is to explain, in a human language, the ideas of (several) forthcoming statements so that the program becomes easier to understand for humans. Some variables whose names are not completely self-explanatory also need a comment.

Object Types. There are many different types of objects in Python. In this chapter we have worked with

- integers (whole numbers, object type `int`):

```
x10 = 3  
XYZ = 2
```

- floats (decimal numbers, object type float):

```
max_temperature = 3.0
MinTemp = 1/6.0
```

- strings (pieces of text, object type str):

```
a = 'This is a piece of text\nover two lines.'
b = "Strings are enclosed in single or double quotes."
c = """Triple-quoted strings can
span
several lines.
"""
```

- complex numbers (object type complex):

```
a = 2.5 + 3j
real = 6; imag = 3.1
b = complex(real, imag)
```

Operators. Operators in arithmetic expressions follow the rules from mathematics: power is evaluated before multiplication and division, while the latter two are evaluated before addition and subtraction. These rules are overridden by parentheses. We suggest to use parentheses to group and clarify mathematical expressions, also when not strictly needed.

```
-t**2*g/2
-(t**2)*(g/2)          # equivalent
-t**(2*g)/2           # a different formula!

a = 5.0; b = 5.0; c = 5.0
a/b + c + a*c         # yields 31.0
a/(b + c) + a*c       # yields 25.5
a/(b + c + a)*c       # yields 1.6666666666666665
```

Particular attention must be paid to coding fractions, since the division operator `/` often needs extra parentheses that are not necessary in the mathematical notation for fractions (compare $\frac{a}{b+c}$ with `a/(b+c)` and `a/b+c`).

Common Mathematical Functions. The `math` module contains common mathematical functions for real numbers. Modules must be imported before they can be used:

```
import math
a = math.sin(math.pi*1.5)
```

OR

```
from math import *
a = sin(pi*1.5)
```

OR

```
from math import sin, pi
a = sin(pi*1.5)
```

Print. To print the result of calculations in a Python program to a terminal window, we apply the `print` command, i.e., the word `print` followed by a string enclosed in quotes, or just a variable:

```
print "A string enclosed in double quotes"
print a
```

Several objects can be printed in one statement if the objects are separated by commas. A space will then appear between the output of each object:

```
>>> a = 5.0; b = -5.0; c = 1.9856; d = 33
>>> print 'a is', a, 'b is', b, 'c and d are', c, d
a is 5.0 b is -5.0 c and d are 1.9856 33
```

The `printf` syntax enables full control of the formatting of real numbers and integers:

```
>>> print 'a=%g, b=%12.4E, c=%.2f, d=%5d' % (a, b, c, d)
a=5, b= -5.0000E+00, c=1.99, d= 33
```

Here, `a`, `b`, and `c` are of type `float` and formatted as compactly as possible (`%g` for `a`), in scientific notation with 4 decimals in a field of width 12 (`%12.4E` for `b`), and in decimal notation with two decimals in as compact field as possible (`%.2f` for `c`). The variable `d` is an integer (`int`) written in a field of width 5 characters (`%5d`).

Integer Division. A common error in mathematical computations is to divide two integers, because this results in integer division. Any number written without decimals is treated as an integer. To avoid integer division, ensure that every division involves at least one real number, e.g., $9/5$ is written as `9.0/5`, `9./5`, `9/5.`, or `9/5.0`.

Complex Numbers. Values of complex numbers are written as $(X+Yj)$, where `X` is the value of the real part and `Y` is the value of the imaginary part. One example is `(4-0.2j)`. If the real and imaginary parts are available as variables `r` and `i`, a complex number can be created by `complex(r, i)`.

The `cmath` module must be used instead of `math` if the argument is a complex variable. The `numpy` package offers similar mathematical functions, but with a unified treatment of real and complex variables.

Terminology. Some Python and computer science terms briefly covered in this chapter are

- object: anything that a variable (name) can refer to²⁵ (number, string, function, module, ...)
- variable: name of an object
- statement: an instruction to the computer, usually written on a line in a Python program (multiple statements on a line must be separated by semicolons)
- expression: a combination of numbers, text, variables, and operators that results in a new object, when being evaluated
- assignment: a statement binding an evaluated expression (object) to a variable (name)
- algorithm: detailed recipe for how to solve a problem by programming
- code: program text (or synonym for program)
- implementation: same as code
- executable: the file we run to start the program
- verification: providing evidence that the program works correctly
- debugging: locating and correcting errors in a program

1.7.2 Example: Trajectory of a Ball

Problem. The formula (1.1) computes the height of a ball in vertical motion. What if we throw the ball with an initial velocity having an angle θ with the horizontal? This problem can be solved by basic high school physics as you are encouraged to do in Exercise 1.13. The ball will follow a trajectory $y = f(x)$ through the air²⁶, where

$$f(x) = x \tan \theta - \frac{1}{2v_0^2} \frac{gx^2}{\cos^2 \theta} + y_0. \quad (1.5)$$

In this expression, x is a horizontal coordinate, g is the acceleration of gravity, v_0 is the size of the initial velocity which makes an angle θ with the x axis, and $(0, y_0)$ is the initial position of the ball. Our programming goal is to make a program for evaluating (1.5). The program should write out the value of all the involved variables and what their units are.

Solution. We use the SI system and assume that v_0 is given in km/h; $g = 9.81 \text{ m/s}^2$; x , y , and y_0 are measured in meters; and θ in degrees. The program has naturally four parts: initialization of input data, import of functions and π from `math`, conversion of v_0 and θ to m/s and

²⁵ But objects can exist without being bound to a name: `print 'Hello!'` first makes a string object of the text in quotes and then the contents of this string object, without a name, is printed.

²⁶ This formula neglects air resistance. Exercise 1.11 explores how important air resistance is. For a soft kick ($v_0 = 10 \text{ km/h}$) of a football, the gravity force is about 120 times larger than the air resistance. For a hard kick, air resistance may be as important as gravity.

radians, respectively, and evaluation of the right-hand side expression in (1.5). We choose to write out all numerical values with one decimal. The complete program is found in the file `trajectory.py`:

```

g = 9.81      # m/s**2
v0 = 15      # km/h
theta = 60   # degrees
x = 0.5      # m
y0 = 1       # m

print """\
v0   = %.1f km/h
theta = %d degrees
y0   = %.1f m
x    = %.1f m\
""" % (v0, theta, y0, x)

from math import pi, tan, cos
# Convert v0 to m/s and theta to radians
v0 = v0/3.6
theta = theta*pi/180

y = x*tan(theta) - 1/(2*v0**2)*g*x**2/((cos(theta))**2) + y0

print 'y      = %.1f m' % y

```

The backslash in the triple-quoted multi-line string makes the string continue on the next line without a newline. This means that removing the backslash results in a blank line above the `v0` line and a blank line between the `x` and `y` lines in the output on the screen. Another point to mention is the expression $1/(2*v0**2)$, which might seem as a candidate for unintended integer division. However, the conversion of `v0` to m/s involves a division by 3.6, which results in `v0` being `float`, and therefore $2*v0**2$ being `float`. The rest of the program should be self-explanatory at this stage in the book.

We can execute the program in IPython or an ordinary terminal window and watch the output:

Terminal

```

v0   = 15.0 km/h
theta = 60 degrees
y0   = 1.0 m
x    = 0.5 m
y    = 1.6 m

```

1.7.3 About Typesetting Conventions in This Book

This version of the book applies different design elements for different types of “computer text”. Complete programs and parts of programs (snippets) are typeset with a light blue background. A snippet looks like this:

```
a = sqrt(4*p + c)
print 'a =', a
```

A complete program has an additional vertical line to the left:

```
C = 21
F = (9.0/5)*C + 32
print F
```

As a reader of this book, you may wonder if a code shown is a complete program you can try out or if it is just a part of a program (a snippet) so that you need to add surrounding statements (e.g., import statements) to try the code out yourself. The appearance of a vertical line to the left or not will then quickly tell you what type of code you see.

An interactive Python session is typeset as

```
>>> from math import *
>>> p = 1; c = -1.5
>>> a = sqrt(4*p + c)
```

Running a program, say `ball_yc.py`, in the terminal window, followed by some possible output is typeset as²⁷

```
Terminal
```

```
ball_yc.py
At t=0.0417064 s and 0.977662 s, the height is 0.2 m.
```

Sometimes just the output from a program is shown, and this output appears as plain “computer text”:

```
h = 0.2
order=0, error=0.221403
order=1, error=0.0214028
order=2, error=0.00140276
order=3, error=6.94248e-05
order=4, error=2.75816e-06
```

Files containing data are shown in a similar way in this book:

date	Oslo	London	Berlin	Paris	Rome	Helsinki
01.05	18	21.2	20.2	13.7	15.8	15
01.06	21	13.2	14.9	18	24	20
01.07	13	14	16	25	26.2	14.5

1.8 Exercises

What Does It Mean to Solve an Exercise? The solution to most of the exercises in this book is a Python program. To produce the solution,

²⁷ Recall from Chapter 1.5.3 that we just write the program name. A real execution demands prefixing the program name by `python` in a DOS/Unix terminal window, or by `run` if you run the program from an interactive IPython session. We refer to Appendix H.1 for more complete information on running Python programs in different ways.

you first need understand the problem and what the program is supposed to do, and then you need to understand how to translate the problem description into a series of Python statements. Equally important is the verification (testing) of the program. A complete solution to a programming exercises therefore consists of two parts: the program text and a demonstration that the program works correctly. Some simple programs, like the ones in the first two exercises below, have so simple output that the verification can just be to run the program and record the output.

In cases where the correctness of the output is not obvious, it is necessary to provide information together with the output to “prove” that the result is correct. This can be a calculation done separately on a calculator, or one can apply the program to a special simple test with known results. The requirement is to provide evidence that the program works as intended.

The sample run of the program to check its correctness can be inserted at the end of the program as a triple-quoted string²⁸. The contents of the string can be text from the run in the terminal window, cut and pasted to the program file by the aid of the mouse. Alternatively, one can run the program and direct the output to a file²⁹:

Terminal

```
Terminal> python myprogram.py > result
```

Afterwards, use the editor to insert the file `result` inside the string.

As an example, suppose we are to write a program for converting Fahrenheit degrees to Celsius. The solution process can be divided into three steps:

1. Establish the mathematics to be implemented: solving (1.2) with respect to C gives the conversion formula

$$C = \frac{5}{9}(F - 32).$$

2. Coding of the formula in Python: `C = (5.0/9)*(F - 32)`
3. Establish a test case: from the `c2f.py` program in Chapter 1.3.3 we know that $C = 21$ corresponds to $F = 69.8$. We can therefore, in our new program, set $F = 69.8$ and check that $C = 21$. The output from a run can be appended as a triple quoted string at the end of the program.

²⁸ Alternatively, the output lines can be inserted as comments, but using a multi-line string requires less typing. (Technically, a string object is created, but not assigned to any name or used for anything in the program – but for a human the text in the string contains useful information.)

²⁹ The redirection to files does not work if the program is run inside IPython. In a DOS terminal window you may also choose to redirect output to a file, because cut and paste between the DOS window and the program window does not work by default unless you right-click the top bar, choose Properties and tick off Quick Edit Mode.

An appropriate complete solution to the exercise is then

```
# Convert from Fahrenheit degrees to Celsius degrees:
F = 69.8
C = (5.0/9)*(F - 32)
print C

'''
Sample run:
python f2c.py
21.0
'''
```

Exercise 1.1. *Compute 1+1.*

The first exercise concerns some very basic mathematics and programming: assign the result of 1+1 to a variable and print the value of that variable. Name of program file: `1plus1.py`. ◇

Exercise 1.2. *Write a “Hello, World!” program.*

Almost all books about programming languages start with a very simple program that prints the text “Hello, World!” on the screen. Make such a program in Python. Name of program file: `hello_world.py`. ◇

Exercise 1.3. *Derive and compute a formula.*

Can a newborn baby in Norway expect to live for one billion (10^9) seconds? Name of program file: `seconds2years.py`. ◇

Exercise 1.4. *Convert from meters to British length units.*

Make a program where you set a length given in meters and then compute and write out the corresponding length measured in inches, in feet, in yards, and in miles. Use that one inch is 2.54 cm, one foot is 12 inches, one yard is 3 feet, and one British mile is 1760 yards. As a verification, a length of 640 meters corresponds to 25196.85 inches, 2099.74 feet, 699.91 yards, or 0.3977 miles. Name of program file: `length_conversion.py`. ◇

Exercise 1.5. *Compute the mass of various substances.*

The density of a substance is defined as $\rho = m/V$, where m is the mass of a volume V . Compute and print out the mass of one liter of each of the following substances whose densities in g/cm^3 are found in the file `src/files/densities.dat`: iron, air, gasoline, ice, the human body, silver, and platinum: 21.4. Name of program file: `1liter.py`. ◇

Exercise 1.6. *Compute the growth of money in a bank.*

Let p be a bank’s interest rate in percent per year. An initial amount A has then grown to

$$A \left(1 + \frac{p}{100} \right)^n$$

after n years. Make a program for computing how much money 1000 euros have grown to after three years with 5% interest rate. Name of program file: `interest_rate.py`. ◇

Exercise 1.7. *Find error(s) in a program.*

Suppose somebody has written a simple one-line program for computing $\sin(1)$:

```
x=1; print 'sin(%g)=%g' % (x, sin(x))
```

Type in this program and try to run it. What is the problem? \diamond

Exercise 1.8. *Type in program text.*

Type the following program in your editor and execute it. If your program does not work, check that you have copied the code correctly.

```
from math import pi

h = 5.0 # height
b = 2.0 # base
r = 1.5 # radius

area_parallelogram = h*b
print 'The area of the parallelogram is %.3f' % area_parallelogram

area_square = b**2
print 'The area of the square is %g' % area_square

area_circle = pi*r**2
print 'The area of the circle is %.3f' % area_circle

volume_cone = 1.0/3*pi*r**2*h
print 'The volume of the cone is %.3f' % volume_cone
```

Name of program file: `formulas_shapes.py`. \diamond

Exercise 1.9. *Type in programs and debug them.*

Type these short programs in your editor and execute them. When they do not work, identify and correct the erroneous statements.

(a) Does $\sin^2(x) + \cos^2(x) = 1$?

```
from math import sin, cos
x = pi/4
1_val = sin^2(x) + cos^2(x)
print 1_VAL
```

Name of program file: `sin2_plus_cos2.py`

(b) Work with the expressions for movement with constant acceleration:

```
v0 = 3 m/s
t = 1 s
a = 2 m/s**2
s = v0*t + 1/2 a*t**2
print s
```

Name of program file: `acceleration.py`

(c) Verify these equations:

$$(a + b)^2 = a^2 + 2ab + b^2$$

$$(a - b)^2 = a^2 - 2ab + b^2$$

```

a = 3,3   b = 5,3
a2 = a**2
b2 = b**2

eq1_sum = a2 + 2ab + b2
eq2_sum = a2 - 2ab + b2

eq1_pow = (a + b)**2
eq2_pow = (a - b)**2

print 'First equation: %g = %g', % (eq1_sum, eq1_pow)
print 'Second equation: %h = %h', % (eq2_pow, eq2_pow)

```

Name of program file: `a_pm_b_sqr.py` ◇

Exercise 1.10. *Evaluate a Gaussian function.*

The bell-shaped Gaussian function,

$$f(x) = \frac{1}{\sqrt{2\pi} s} \exp \left[-\frac{1}{2} \left(\frac{x - m}{s} \right)^2 \right], \quad (1.6)$$

is one of the most widely used functions in science and technology³⁰. The parameters m and s are real numbers, where s must be greater than zero. Make a program for evaluating this function when $m = 0$, $s = 2$, and $x = 1$. Verify the program's result by comparing with hand calculations on a calculator. Name of program file: `Gaussian1.py`. ◇

Exercise 1.11. *Compute the air resistance on a football.*

The drag force, due to air resistance, on an object can be expressed as

$$F_d = \frac{1}{2} C_D \rho A V^2, \quad (1.7)$$

where ρ is the density of the air, V is the velocity of the object, A is the cross-sectional area (normal to the velocity direction), and C_D is the drag coefficient, which depends heavily on the shape of the object and the roughness of the surface.

The gravity force on an object with mass m is $F_g = mg$, where $g = 9.81 \text{ m s}^{-2}$.

We can use the formulas for F_d and F_g to study the importance of air resistance versus gravity when kicking a football. The density of air is $\rho = 1.2 \text{ kg m}^{-3}$. We have $A = \pi a^2$ for any ball with radius a . For a football $a = 11 \text{ cm}$. The mass of a football is 0.43 kg , C_D can be taken as 0.2 .

Make a program that computes the drag force and the gravity force on a football. Write out the forces with one decimal in units of Newton ($\text{N} = \text{kg m/s}^2$). Also print the ratio of the drag force and the gravity force. Define C_D , ρ , A , V , m , g , F_d , and F_g as variables, and put

³⁰ The function is named after [Carl Friedrich Gauss](#), 1777–1855, who was a German mathematician and scientist, now considered as one of the greatest scientists of all time. He contributed to many fields, including number theory, statistics, mathematical analysis, differential geometry, geodesy, electrostatics, astronomy, and optics. Gauss introduced the function (1.6) when he analyzed probabilities related to astronomical data.

a comment with the corresponding unit. Use the program to calculate the forces on the ball for a hard kick, $V = 120$ km/h and for a soft kick, $V = 10$ km/h (it is easy to mix inconsistent units, so make sure you compute with V expressed in m/s). Name of program file: `kick.py`. \diamond

Exercise 1.12. *How to cook the perfect egg.*

As an egg cooks, the proteins first denature and then coagulate. When the temperature exceeds a critical point, reactions begin and proceed faster as the temperature increases. In the egg white the proteins start to coagulate for temperatures above 63 C, while in the yolk the proteins start to coagulate for temperatures above 70 C. For a soft boiled egg, the white needs to have been heated long enough to coagulate at a temperature above 63 C, but the yolk should not be heated above 70 C. For a hard boiled egg, the center of the yolk should be allowed to reach 70 C.

The following formula expresses the time t it takes (in seconds) for the center of the yolk to reach the temperature T_y (in Celsius degrees):

$$t = \frac{M^{2/3} c \rho^{1/3}}{K \pi^2 (4\pi/3)^{2/3}} \ln \left[0.76 \frac{T_o - T_w}{T_y - T_w} \right]. \quad (1.8)$$

Here, M , ρ , c , and K are properties of the egg: M is the mass, ρ is the density, c is the specific heat capacity, and K is thermal conductivity. Relevant values are $M = 47$ g for a small egg and $M = 67$ g for a large egg, $\rho = 1.038$ g cm⁻³, $c = 3.7$ J g⁻¹ K⁻¹, and $K = 5.4 \cdot 10^{-3}$ W cm⁻¹ K⁻¹. Furthermore, T_w is the temperature (in C degrees) of the boiling water, and T_o is the original temperature (in C degrees) of the egg before being put in the water. Implement the formula in a program, set $T_w = 100$ C and $T_y = 70$ C, and compute t for a large egg taken from the fridge ($T_o = 4$ C) and from room temperature ($T_o = 20$ C). Name of program file: `egg.py`. \diamond

Exercise 1.13. *Derive the trajectory of a ball.*

The purpose of this exercise is to explain how Equation (1.5) for the trajectory of a ball arises from basic physics. There is no programming in this exercise, just physics and mathematics.

The motion of the ball is governed by Newton's second law:

$$F_x = ma_x \quad (1.9)$$

$$F_y = ma_y \quad (1.10)$$

where F_x and F_y are the sum of forces in the x and y directions, respectively, a_x and a_y are the accelerations of the ball in the x and y directions, and m is the mass of the ball. Let $(x(t), y(t))$ be the position of the ball, i.e., the horizontal and vertical coordinate of the ball at time t . There are well-known relations between acceleration, velocity, and position: the acceleration is the time derivative of the velocity, and

the velocity is the time derivative of the position. Therefore we have that

$$a_x = \frac{d^2x}{dt^2}, \quad (1.11)$$

$$a_y = \frac{d^2y}{dt^2}. \quad (1.12)$$

If we assume that gravity is the only important force on the ball, $F_x = 0$ and $F_y = -mg$.

Integrate the two components of Newton's second law twice. Use the initial conditions on velocity and position,

$$\frac{d}{dt}x(0) = v_0 \cos \theta, \quad (1.13)$$

$$\frac{d}{dt}y(0) = v_0 \sin \theta, \quad (1.14)$$

$$x(0) = 0, \quad (1.15)$$

$$y(0) = y_0, \quad (1.16)$$

to determine the four integration constants. Write up the final expressions for $x(t)$ and $y(t)$. Show that if $\theta = \pi/2$, i.e., the motion is purely vertical, we get the formula (1.1) for the y position. Also show that if we eliminate t , we end up with the relation (1.5) between the x and y coordinates of the ball. You may read more about this type of motion in a physics book, e.g., [6]. \diamond

Exercise 1.14. *Find errors in the coding of formulas.*

Some versions of our program for calculating the formula (1.2) are listed below. Determine which versions that will not work correctly and explain why in each case.

```
C = 21;    F = 9/5*C + 32;    print F
C = 21.0;  F = (9/5)*C + 32;  print F
C = 21.0;  F = 9*C/5 + 32;   print F
C = 21.0;  F = 9.*(C/5.0) + 32; print F
C = 21.0;  F = 9.0*C/5.0 + 32; print F
C = 21;    F = 9*C/5 + 32;   print F
C = 21.0;  F = (1/5)*9*C + 32; print F
C = 21;    F = (1./5)*9*C + 32; print F
```

\diamond

Exercise 1.15. *Explain why a program does not work.*

Find out why the following program does not work:

```
C = A + B
A = 3
B = 2
print C
```

\diamond

Exercise 1.16. *Find errors in Python statements.*

Try the following statements in an interactive Python shell. Explain why some statements fail and correct the errors.

```
1a = 2
a1 = b
x = 2
y = X + 4 # is it 6?
from Math import tan
print tan(pi)
pi = "3.14159"
print tan(pi)
c = 4**3**2**3
_ = ((c-78564)/c + 32))
discount = 12%
AMOUNT = 120.-
amount = 120$
address = hpl@simula.no
and = duck
class = 'INF1100, gr 2"
continue_ = x > 0
rev = fox = True
Norwegian = ['a human language']
true = fox is rev in Norwegian
```

Hint: It might be wise to test the values of the expressions on the right-hand side, and the validity of the variable names, separately before you put the left- and right-hand sides together in statements. The last two statements work, but explaining why goes beyond what is treated in this chapter. \diamond

Exercise 1.17. *Find errors in the coding of a formula.*

Given a quadratic equation,

$$ax^2 + bx + c = 0,$$

the two roots are

$$x_1 = \frac{-b + \sqrt{b^2 - 4ac}}{2a}, \quad x_2 = \frac{-b - \sqrt{b^2 - 4ac}}{2a}. \quad (1.17)$$

What are the problems with the following program?

```
a = 2; b = 1; c = 2
from math import sqrt
q = sqrt(b*b - 4*a*c)
x1 = (-b + q)/2*a
x2 = (-b - q)/2*a
print x1, x2
```

Hint: Compute all terms in (1.17) with the aid of a calculator, and compare with the corresponding intermediate results computed in the program (you need to add some `print` statements to see the result of `q`, `-b+q`, and `2*a`). \diamond

This chapter shows how repetitive tasks in a program can be automated by loops. We also introduce list objects for storing and processing collections of data with a specific order. Loops and lists, together with functions and if-tests from Chapter 3, lay the fundamental programming foundation for the rest of the book. The programs associated with the chapter are found in the folder `src/looplist`.

2.1 While Loops

Our task now is to print out a conversion table with Celsius degrees in the first column of the table and the corresponding Fahrenheit degrees in the second column. Such a table may look like this:

-20	-4.0
-15	5.0
-10	14.0
-5	23.0
0	32.0
5	41.0
10	50.0
15	59.0
20	68.0
25	77.0
30	86.0
35	95.0
40	104.0

2.1.1 A Naive Solution

Since we know how to evaluate the formula (1.2) for one value of C , we can just repeat these statements as many times as required for the table above. Using three statements per line in the program, for compact layout of the code, we can write the whole program as

```

C = -20; F = 9.0/5*C + 32; print C, F
C = -15; F = 9.0/5*C + 32; print C, F
C = -10; F = 9.0/5*C + 32; print C, F
C = -5; F = 9.0/5*C + 32; print C, F
C = 0; F = 9.0/5*C + 32; print C, F
C = 5; F = 9.0/5*C + 32; print C, F
C = 10; F = 9.0/5*C + 32; print C, F
C = 15; F = 9.0/5*C + 32; print C, F
C = 20; F = 9.0/5*C + 32; print C, F
C = 25; F = 9.0/5*C + 32; print C, F
C = 30; F = 9.0/5*C + 32; print C, F
C = 35; F = 9.0/5*C + 32; print C, F
C = 40; F = 9.0/5*C + 32; print C, F

```

Running this program, which is stored in the file `c2f_table_repeat.py`, demonstrates that the output becomes

```

-20 -4.0
-15 5.0
-10 14.0
-5 23.0
0 32.0
5 41.0
10 50.0
15 59.0
20 68.0
25 77.0
30 86.0
35 95.0
40 104.0

```

This output suffers from somewhat ugly formatting, but that problem can quickly be fixed by replacing `print C, F` by a `print` statement based on `printf` formatting. We will return to this detail later.

The main problem with the program above is that lots of statements are identical and repeated. First of all it is boring to write this sort of repeated statements, especially if we want many more C and F values in the table. Second, the idea of the computer is to automate repetition. Therefore, all computer languages have constructs to efficiently express repetition. These constructs are called *loops* and come in two variants in Python: `while` loops and `for` loops. Most programs in this book employ loops, so this concept is extremely important to learn.

2.1.2 While Loops

The `while` loop is used to repeat a set of statements as long as a condition is true. We shall introduce this kind of loop through an example. The task is to generate the rows of the table of C and F values. The C value starts at -20 and is incremented by 5 as long as $C \leq 40$. For each C value we compute the corresponding F value and write out the two temperatures. In addition, we also add a line of hyphens above and below the table. We postpone to nicely format the C and F columns of numbers and perform for simplicity a plain `print C, F` statement inside the loop.

Using a mathematical type of notation, we could write the `while` loop as follows:

```

C = -20
while C ≤ 40 repeat the following:
    F =  $\frac{9}{5}C + 32$ 
    print C, F
    set C to C + 5

```

The three lines after the “while” line are to be repeated as long as the condition $C \leq 40$ is true. This algorithm will then produce a table of C and corresponding F values.

A complete Python program, implementing the repetition algorithm above, looks quite similar¹:

```

print '-----'      # table heading
C = -20              # start value for C
dC = 5              # increment of C in loop
while C <= 40:      # loop heading with condition
    F = (9.0/5)*C + 32 # 1st statement inside loop
    print C, F        # 2nd statement inside loop
    C = C + dC        # 3rd statement inside loop
print '-----'      # end of table line (after loop)

```

A very important feature of Python is now encountered: The block of statements to be executed in each pass of the `while` loop must be indented. In the example above the block consists of three lines, and all these lines must have exactly the same indentation. Our choice of indentation in this book is four spaces. The first statement whose indentation coincides with that of the `while` line marks the end of the loop and is executed after the loop has terminated. In this example this is the final `print` statement. You are encouraged to type in the code above in a file, indent the last line four spaces, and observe what happens (you will experience that lines in the table are separated by a line of dashes: -----).

Many novice Python programmers forget the colon at the end of the `while` line – this colon is essential and marks the beginning of the indented block of statements inside the loop. Later, we will see that there are many other similar program constructions in Python where there is a heading ending with a colon, followed by an indented block of statements.

Programmers need to fully understand what is going on in a program and be able to simulate the program by hand. Let us do this with the program segment above. First, we define the start value for the sequence of Celsius temperatures: $C = -20$. We also define the increment dC that will be added to C inside the loop. Then we enter the loop condition $C \leq 40$. The first time C is -20 , which implies that $C \leq 40$ (equivalent to $C \leq 40$ in mathematical notation) is true. Since the loop condition is true, we enter the loop and execute all the indented statements.

¹ For this table we also add (of teaching purposes) a line above and below the table.

That is, we compute F corresponding to the current C value, print the temperatures, and increment C by dC .

Thereafter, we enter the second pass in the loop. First we check the condition: C is -15 and $C \leq 40$ is still true. We execute the statements in the indented loop block, C becomes -10 , this is still less than or equal to 40 , so we enter the loop block again. This procedure is repeated until C is updated from 40 to 45 in the final statement in the loop block. When we then test the condition, $C \leq 40$, this condition is no longer true, and the loop is terminated. We proceed with the next statement that has the same indentation as the `while` statement, which is the final `print` statement in this example.

Newcomers to programming are sometimes confused by statements like

```
C = C + dC
```

This line looks erroneous from a mathematical viewpoint, but the statement is perfectly valid computer code, because we first evaluate the expression on the right-hand side of the equality sign and then let the variable on the left-hand side refer to the result of this evaluation. In our case, C and dC are two different `int` objects. The operation $C+dC$ results in a new `int` object, which in the assignment $C = C+dC$ is bound to the name C . Before this assignment, C was already bound to a `int` object, and this object is automatically destroyed when C is bound to a new object and there are no other names (variables) referring to this previous object².

Since incrementing the value of a variable is frequently done in computer programs, there is a special short-hand notation for this and related operations:

```
C += dC # equivalent to C = C + dC
C -= dC # equivalent to C = C - dC
C *= dC # equivalent to C = C*dC
C /= dC # equivalent to C = C/dC
```

2.1.3 Boolean Expressions

In our first example on a `while` loop, we worked with a condition $C \leq 40$, which evaluates to either `true` or `false`, written as `True` or `False` in Python. Other comparisons are also useful:

```
C == 40 # C equals 40
C != 40 # C does not equal 40
C >= 40 # C is greater than or equal to 40
C > 40  # C is greater than 40
C < 40  # C is less than 40
```

² If you did not get the last point here, just relax and continue reading.

Not only comparisons between numbers can be used as conditions in `while` loops: Any expression that has a boolean (`True` or `False`) value can be used. Such expressions are known as *logical* or *boolean* expressions.

The keyword `not` can be inserted in front of the boolean expression to change the value from `True` to `False` or from `False` to `True`. To evaluate `not C == 40`, we first evaluate `C == 40`, for `C = 1` this is `False`, and then `not` turns the value into `True`. On the opposite, if `C == 40` is `True`, `not C == 40` becomes `False`. Mathematically it is easier to read `C != 40` than `not C == 40`, but these two boolean expressions are equivalent.

Boolean expressions can be combined with `and` and `or` to form new compound boolean expressions, as in

```
while x > 0 and y <= 1:
    print x, y
```

If `cond1` and `cond2` are two boolean expressions with values `True` or `False`, the compound boolean expression `cond1 and cond2` is `True` if both `cond1` and `cond2` are `True`. On the other hand, `cond1 or cond2` is `True` if at least one of the conditions, `cond1` or `cond2`, is `True`³

Here are some more examples from an interactive session where we just evaluate the boolean expressions themselves without using them in loop conditions:

```
>>> x = 0; y = 1.2
>>> x >= 0 and y < 1
False
>>> x >= 0 or y < 1
True
>>> x > 0 or y > 1
True
>>> x > 0 or not y > 1
False
>>> -1 < x <= 0 # -1 < x and x <= 0
True
>>> not (x > 0 or y > 0)
False
```

In the last sample expression, `not` applies to the value of the boolean expression inside the parentheses: `x>0` is `False`, `y>0` is `True`, so the combined expression with `or` is `True`, and `not` turns this value to `False`.

The common⁴ boolean values in Python are `True`, `False`, `0` (false), and any integer different from zero (true). To see such values in action, we recommend to do Exercises 2.25 and 2.21.

³ In Python, `cond1 and cond2` or `cond1 or cond2` returns one of the operands and not just `True` or `False` values as in most other computer languages. The operands `cond1` or `cond2` can be expressions or objects. In case of expressions, these are first evaluated to an object before the compound boolean expression is evaluated. For example, `(5+1) or -1` evaluates to `6` (the second operand is not evaluated when the first one is `True`), and `(5+1) and -1` evaluates to `-1`.

⁴ All objects in Python can in fact be evaluated in a boolean context, and all are `True` except `False`, zero numbers, and empty strings, lists, and dictionaries. See Exercise 6.24 for more details.

Erroneous thinking about boolean expressions is one of the most common sources of errors in computer programs, so you should be careful every time you encounter a boolean expression and check that it is correctly stated.

2.1.4 Loop Implementation of a Sum

Summations frequently appear in mathematics. For instance, the sine function can be calculated as a polynomial:

$$\sin(x) \approx x - \frac{x^3}{3!} + \frac{x^5}{5!} - \frac{x^7}{7!} + \cdots, \quad (2.1)$$

where $3! = 3 \cdot 2 \cdot 1$, $5! = 5 \cdot 4 \cdot 3 \cdot 2 \cdot 1$, etc., are factorials. The expression $k! = k(k-1)(k-2) \cdots 2 \cdot 1$ can be computed by `math.factorial(k)`.

An infinite number of terms are needed on the right-hand side of (2.1) for the equality sign to hold. With a finite number of terms, we obtain an approximation to $\sin(x)$, which is well suited for being calculated in a program since only powers and the basic four arithmetic operations are involved. Say we want to compute the right-hand side of (2.1) for powers up to $N = 25$. Writing out and implementing each one of these terms is a tedious job that can easily be automated by a loop.

Computation of the sum in (2.1) by a `while` loop in Python, makes use of (i) a counter `k` that runs through odd numbers from 1 up to some given maximum power `N`, and (ii) a summation variable, say `s`, which accumulates the terms, one at a time. The purpose of each pass of the loop is to compute a new term and add it to `s`. Since the sign of each term alternates, we introduce a variable `sign` that changes between -1 and 1 in each pass of the loop.

The previous paragraph can be precisely expressed by this piece of Python code:

```
x = 1.2 # assign some value
N = 25 # maximum power in sum
k = 1
s = x
sign = 1.0
import math

while k < N:
    sign = - sign
    k = k + 2
    term = sign*x**k/math.factorial(k)
    s = s + term

print 'sin(%g) = %g (approximation with %d terms)' % (x, s, N)
```

The best way to understand such a program is to simulate it by hand. That is, we go through the statements, one by one, and write down on a piece of paper what the state of each variable is.

When the loop is first entered, $k < N$ implies $1 < 25$, which is `True` so we enter the loop block. There, we compute `sign = -1.0`, `k = 3`, `term = -1.0*x**3/(3*2*1)` (note that `sign` is float so we always have float divided by int), and `s = x - x**3/6`, which equals the first two terms in the sum. Then we test the loop condition: $3 < 25$ is `True` so we enter the loop block again. This time we obtain `term = 1.0*x**5/math.factorial(5)`, which correctly implements the third term in the sum. At some point, `k` is updated to from 23 to 25 inside the loop and the loop condition then becomes $25 < 25$, which is `False`, implying that the program jumps over the loop block and continues with the `print` statement (which has the same indentation as the `while` statement).

2.2 Lists

Up to now a variable has typically contained a single number. Sometimes numbers are naturally grouped together. For example, all Celsius degrees in the first column of our table from Chapter 2.1.2 could be conveniently stored together as a group. A Python *list* can be used to represent such a group of numbers in a program. With a variable that refers to the list, we can work with the whole group at once, but we can also access individual elements of the group. Figure 2.1 illustrates the difference between an `int` object and a list object. In general, a list may contain a sequence of arbitrary objects in a given order. Python has great functionality for examining and manipulating such sequences of objects, which will be demonstrated below.

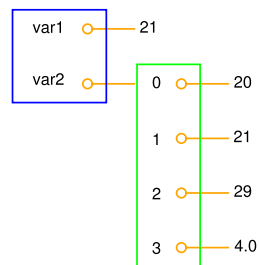

Fig. 2.1 Illustration of two variables: `var1` refers to an `int` object with value 21, created by the statement `var1 = 21`, and `var2` refers to a `list` object with value `[20, 21, 29, 4.0]`, i.e., three `int` objects and one `float` object, created by the statement `var2 = [20, 21, 29, 4.0]`.

2.2.1 Basic List Operations

To create a list with the numbers from the first column in our table, we just put all the numbers inside square brackets and separate the

numbers by commas:

```
C = [-20, -15, -10, -5, 0, 5, 10, 15, 20, 25, 30, 35, 40]
```

The variable `C` now refers to a `list` object holding 13 list *elements*. All list elements are in this case `int` objects.

Every element in a list is associated with an *index*, which reflects the position of the element in the list. The first element has index 0, the second index 1, and so on. Associated with the `C` list above we have 13 indices, starting with 0 and ending with 12. To access the element with index 3, i.e., the fourth element in the list, we can write `C[3]`. As we see from the list, `C[3]` refers to an `int` object with the value `-5`.

Elements in lists can be deleted, and new elements can be inserted anywhere. The functionality for doing this is built into the list object and accessed by a dot notation. Two examples are `C.append(v)`, which appends a new element `v` to the end of the list, and `C.insert(i,v)`, which inserts a new element `v` in position number `i` in the list. The number of elements in a list is given by `len(C)`. Let us exemplify some list operations in an interactive session to see the effect of the operations:

```
>>> C = [-10, -5, 0, 5, 10, 15, 20, 25, 30]      # create list
>>> C.append(35)                               # add new element 35 at the end
>>> C                                           # view list C
[-10, -5, 0, 5, 10, 15, 20, 25, 30, 35]
```

Two lists can be added:

```
>>> C = C + [40, 45]                           # extend C at the end
>>> C
[-10, -5, 0, 5, 10, 15, 20, 25, 30, 35, 40, 45]
```

What adding two lists means is up to the list object to define⁵, but not surprisingly, addition of two lists is defined as appending the second list to the first. The result of `C + [40,45]` is a new list object, which we then assign to `C` such that this name refers to this new list.

New elements can in fact be inserted anywhere in the list (not only at the end as we did with `C.append()`):

```
>>> C.insert(0, -15)                           # insert new element -15 as index 0
>>> C
[-15, -10, -5, 0, 5, 10, 15, 20, 25, 30, 35, 40, 45]
```

⁵ Every object in Python and everything you can do with them is defined by programs made by humans. With the techniques of Chapter 7 you can create your own objects and define (if desired) what it means to add such objects. All this gives enormous power in the hands of programmers. As one example, you can easily define your own list objects if you are not satisfied with Python's own lists.

With `del C[i]` we can remove an element with index `i` from the list `C`. Observe that this changes the list, so `C[i]` refers to another (the next) element after the removal:

```
>>> del C[2]                # delete 3rd element
>>> C
[-15, -10, 0, 5, 10, 15, 20, 25, 30, 35, 40, 45]
>>> del C[2]                # delete what is now 3rd element
>>> C
[-15, -10, 5, 10, 15, 20, 25, 30, 35, 40, 45]
>>> len(C)                  # length of list
11
```

The command `C.index(10)` returns the index corresponding to the first element with value 10 (this is the 4th element in our sample list, with index 3):

```
>>> C.index(10)             # find index for an element (10)
3
```

To just test if an object with the value 10 is an element in the list, one can write the boolean expression `10 in C`:

```
>>> 10 in C                 # is 10 an element in C?
True
```

Python allows negative indices, which “count from the right”. As demonstrated below, `C[-1]` gives the last element of the list `C`. `C[-2]` is the element before `C[-1]`, and so forth.

```
>>> C[-1]                   # view the last list element
45
>>> C[-2]                   # view the next last list element
40
```

Building long lists by writing down all the elements separated by commas is a tedious process that can easily be automated by a loop, using ideas from Chapter 2.1.4. Say we want to build a list of degrees from -50 to 200 in steps of 2.5 degrees. We then start with an empty list and use a `while` loop to append one element at a time:

```
C = []
C_value = -50
C_max = 200
while C_value <= C_max:
    C.append(C_value)
    C_value += 2.5
```

In the next sections, we shall see how we can express these six lines of code with just one single statement.

There is a compact syntax for creating variables that refer to the various list elements. Simply list a sequence of variables on the left-hand side of an assignment to a list:

```
>>> somelist = ['book.tex', 'book.log', 'book.pdf']
>>> texfile, logfile, pdf = somelist
>>> texfile
'book.tex'
>>> logfile
'book.log'
>>> pdf
'book.pdf'
```

The number of variables on the left-hand side must match the number of elements in the list, otherwise an error occurs.

A final comment regards the syntax: some list operations are reached by a dot notation, as in `C.append(e)`, while other operations requires the list object as an argument to a function, as in `len(C)`. Although `C.append` for a programmer behaves as a function, it is a function that is reached through a list object, and it is common to say that `append` is a *method* in the list object, not a function. There are no strict rules in Python whether functionality regarding an object is reached through a method or a function.

2.2.2 For Loops

The Nature of For Loops. When data are collected in a list, we often want to perform the same operations on each element in the list. We then need to walk through all list elements. Computer languages have a special construct for doing this conveniently, and this construct is in Python and many other languages called a *for loop*. Let us use a *for loop* to print out all list elements:

```
degrees = [0, 10, 20, 40, 100]
for C in degrees:
    print 'list element:', C
print 'The degrees list has', len(degrees), 'elements'
```

The `for C in degrees` construct creates a loop over all elements in the list `degrees`. In each pass of the loop, the variable `C` refers to an element in the list, starting with `degrees[0]`, proceeding with `degrees[1]`, and so on, before ending with the last element `degrees[n-1]` (if `n` denotes the number of elements in the list, `len(degrees)`).

The *for loop* specification ends with a colon, and after the colon comes a block of statements which does something useful with the current element. Each statement in the block must be indented, as we explained for *while loops*. In the example above, the block belonging to the *for loop* contains only one statement. The final `print` statement has the same indentation (none in this example) as the `for` statement and is executed as soon as the loop is terminated.

As already mentioned, understanding all details of a program by following the program flow by hand is often a very good idea. Here, we first define a list `degrees` containing 5 elements. Then we enter the `for`

loop. In the first pass of the loop, `C` refers to the first element in the list `degrees`, i.e., the `int` object holding the value 0. Inside the loop we then print out the text 'list element:' and the value of `C`, which is 0. There are no more statements in the loop block, so we proceed with the next pass of the loop. `C` then refers to the `int` object 10, the output now prints 10 after the leading text, we proceed with `C` as the integers 20 and 40, and finally `C` is 100. After having printed the list element with value 100, we move on to the statement after the indented loop block, which prints out the number of list elements. The total output becomes

```
list element: 0
list element: 10
list element: 20
list element: 40
list element: 100
The degrees list has 5 elements
```

Correct indentation of statements is crucial in Python, and we therefore strongly recommend you to work through Exercise 2.26 to learn more about this topic.

Making the Table. Our knowledge of lists and `for` loops over elements in lists puts us in a good position to write a program where we collect all the Celsius degrees to appear in the table in a list `Cdegrees`, and then use a `for` loop to compute and write out the corresponding Fahrenheit degrees. The complete program may look like this:

```
Cdegrees = [-20, -15, -10, -5, 0, 5, 10, 15, 20, 25, 30, 35, 40]
for C in Cdegrees:
    F = (9.0/5)*C + 32
    print C, F
```

The `print C, F` statement just prints the value of `C` and `F` with a default format, where each number is separated by one space character (blank). This does not look like a nice table (the output is identical to the one shown on page 50). Nice formatting is obtained by forcing `C` and `F` to be written in fields of fixed width and with a fixed number of decimals. An appropriate `printf` format is `%5d` (or `%5.0f`) for `C` and `%5.1f` for `F`. We may also add a headline to the table. The complete program becomes:

```
Cdegrees = [-20, -15, -10, -5, 0, 5, 10, 15, 20, 25, 30, 35, 40]
print '    C    F'
for C in Cdegrees:
    F = (9.0/5)*C + 32
    print '%5d %5.1f' % (C, F)
```

This code is found in the file `c2f_table_list.py` and its output becomes

```
    C    F
-20  -4.0
-15   5.0
-10  14.0
```

```

-5 23.0
 0 32.0
 5 41.0
10 50.0
15 59.0
20 68.0
25 77.0
30 86.0
35 95.0
40 104.0

```

2.3 Alternative Implementations with Lists and Loops

We have already solved the problem of printing out a nice-looking conversion table for Celsius and Fahrenheit degrees. Nevertheless, there are usually many alternative ways to write a program that solves a specific problem. The next paragraphs explore some other possible Python constructs and programs to store numbers in lists and print out tables. The various code snippets are collected in the program file `session.py`.

2.3.1 While Loop Implementation of a For Loop

Any for loop can be implemented as a while loop. The general code

```

for element in somelist:
    <process element>

```

can be transformed to this while loop:

```

index = 0
while index < len(somelist):
    element = somelist[index]
    <process element>
    index += 1

```

In particular, the example involving the printout of a table of Celsius and Fahrenheit degrees can be implemented as follows in terms of a while loop:

```

Cdegrees = [-20, -15, -10, -5, 0, 5, 10, 15, 20, 25, 30, 35, 40]
index = 0
print '   C   F'
while index < len(Cdegrees):
    C = Cdegrees[index]
    F = (9.0/5)*C + 32
    print '%5d %5.1f' % (C, F)
    index += 1

```

2.3.2 The Range Construction

It is tedious to write the many elements in the `Cdegrees` in the previous programs. We should use a loop to automate the construction of

the `Cdegrees` list. The `range` construction is particularly useful in this regard:

- `range(n)` generates integers 0, 1, 2, ..., n-1.
- `range(start, stop, step)` generates a sequence of integers `start`, `start+step`, `start+2*step`, and so on up to, *but not including*, `stop`. For example, `range(2, 8, 3)` returns 2 and 5 (and not 8), while `range(1, 11, 2)` returns 1, 3, 5, 7, 9.
- `range(start, stop)` is the same as `range(start, stop, 1)`.

A for loop over integers are written as

```
for i in range(start, stop, step):
    ...
```

We can use this construction to create a `Cdegrees` list of the values `-20, -15, ..., 40`:

```
Cdegrees = []
for C in range(-20, 45, 5):
    Cdegrees.append(C)
```

Note that the upper limit must be greater than 40 to ensure that 40 is included in the range of integers.

Suppose we want to create `Cdegrees` as `-10, -7.5, -5, ..., 40`. This time we cannot use `range` directly, because `range` can only create integers and we have decimal degrees such as `-7.5` and `1.5`. In this case, we introduce an integer counter i and generate the C values by the formula $C = -10 + i \cdot 2.5$ for $i = 0, 1, \dots, 20$. The following Python code implements this task:

```
Cdegrees = []
for i in range(0, 21):
    C = -10 + i*2.5
    Cdegrees.append(C)
```

2.3.3 For Loops with List Indices

Instead of iterating over a list directly with the construction

```
for element in somelist:
    ...
```

we can equivalently iterate of the list indices and index the list inside the loop:

```
for i in range(len(somelist)):
    element = somelist[i]
    ...
```

Since `len(somelist)` returns the length of `somelist` and the largest legal index is `len(somelist)-1`, because indices always start at 0,

`range(len(somelist))` will generate all the correct indices: 0, 1, ..., `len(somelist)-1`.

Programmers coming from other languages, such as Fortran, C, C++, Java, and C#, are very much used to for loops with integer counters and usually tend to use `for i in range(len(somelist))` and work with `somelist[i]` inside the loop. This might be necessary or convenient, but if possible, Python programmers are encouraged to use `for element in somelist`, which is more elegant to read.

Iterating over loop indices is useful when we need to process two lists simultaneously. As an example, we first create two `Cdegrees` and `Fdegrees` lists, and then we make a list to write out a table with `Cdegrees` and `Fdegrees` as the two columns of the table. Iterating over a loop index is convenient in the final list:

```
Cdegrees = []
n = 21
C_min = -10
C_max = 40
dC = (C_max - C_min)/float(n-1) # increment in C
for i in range(0, n):
    C = -10 + i*dC
    Cdegrees.append(C)

Fdegrees = []
for C in Cdegrees:
    F = (9.0/5)*C + 32
    Fdegrees.append(F)

for i in range(len(Cdegrees)):
    C = Cdegrees[i]
    F = Fdegrees[i]
    print '%5.1f %5.1f' % (C, F)
```

Instead of appending new elements to the lists, we can start with lists of the right size, containing zeros, and then index the lists to fill in the right values. Creating a list of length `n` consisting of zeros (for instance) is done by

```
somelist = [0]*n
```

With this construction, the program above can use for loops over indices everywhere:

```
n = 21
C_min = -10
C_max = 40
dC = (C_max - C_min)/float(n-1) # increment in C

Cdegrees = [0]*n
for i in range(len(Cdegrees)):
    Cdegrees[i] = -10 + i*dC

Fdegrees = [0]*n
for i in range(len(Cdegrees)):
    Fdegrees[i] = (9.0/5)*Cdegrees[i] + 32
```



```
for i in range(len(Cdegrees)):
    print '%5.1f %5.1f' % (Cdegrees[i], Fdegrees[i])
```

Note that we need the construction `[0]*n` to create a list of the right length, otherwise the index `[i]` will be illegal.

2.3.4 Changing List Elements

We have two seemingly alternative ways to traverse a list, either a loop over elements or over indices. Suppose we want to change the `Cdegrees` list by adding 5 to all elements. We could try

```
for c in Cdegrees:
    c += 5
```

but this loop leaves `Cdegrees` unchanged, while

```
for i in range(len(Cdegrees)):
    Cdegrees[i] += 5
```

works as intended. What is wrong with the first loop? The problem is that `c` is an ordinary variable which refers to a list element in the loop, but when we execute `c += 5`, we let `c` refer to a new `float` object (`c+5`). This object is never “inserted” in the list. The first two passes of the loop are equivalent to

```
c = Cdegrees[0]    # automatically done in the for statement
c += 5
c = Cdegrees[1]    # automatically done in the for statement
c += 5
```

The variable `c` can only be used to read list elements and never to change them. Only an assignment of the form

```
Cdegrees[i] = ...
```

can change a list element.

There is a way of traversing a list where we get both the index and an element in each pass of the loop:

```
for i, c in enumerate(Cdegrees):
    Cdegrees[i] = c + 5
```

This loop also adds 5 to all elements in the list.

2.3.5 List Comprehension

Because running through a list and for each element creating a new element in another list is a frequently encountered task, Python has a special compact syntax for doing this, called *list comprehension*. The general syntax reads

```
newlist = [E(e) for e in list]
```

where $E(e)$ represents an expression involving element e . Here are three examples:

```
Cdegrees = [-5 + i*0.5 for i in range(n)]
Fdegrees = [(9.0/5)*C + 32 for C in Cdegrees]
C_plus_5 = [C+5 for C in Cdegrees]
```

List comprehensions are recognized as a for loop inside square brackets and will be frequently exemplified throughout the book.

2.3.6 Traversing Multiple Lists Simultaneously

We may use the `Cdegrees` and `Fdegrees` lists to make a table. To this end, we need to traverse both arrays. The `for element in list` construction is not suitable in this case, since it extracts elements from one list only. A solution is to use a for loop over the integer indices so that we can index both lists:

```
for i in range(len(Cdegrees)):
    print '%5d %5.1f' % (Cdegrees[i], Fdegrees[i])
```

It happens quite frequently that two or more lists need to be traversed simultaneously. As an alternative to the loop over indices, Python offers a special nice syntax that can be sketched as

```
for e1, e2, e3, ... in zip(list1, list2, list3, ...):
    # work with element e1 from list1, element e2 from list2,
    # element e3 from list3, etc.
```

The `zip` function turns n lists (`list1`, `list2`, `list3`, ...) into one list of n -tuples, where each n -tuple (`e1`, `e2`, `e3`, ...) has its first element (`e1`) from the first list (`list1`), the second element (`e2`) from the second list (`list2`), and so forth. The loop stops when the end of the shortest list is reached. In our specific case of iterating over the two lists `Cdegrees` and `Fdegrees`, we can use the `zip` function:

```
for C, F in zip(Cdegrees, Fdegrees):
    print '%5d %5.1f' % (C, F)
```

It is considered more “Pythonic” to iterate over list elements, here `C` and `F`, rather than over list indices as in the `for i in range(len(Cdegrees))` construction.

2.4 Nested Lists

Nested lists are list objects where the elements in the lists can be lists themselves. A couple of examples will motivate for nested lists and illustrate the basic operations on such lists.

2.4.1 A Table as a List of Rows or Columns

Our table data have so far used one separate list for each column. If there were n columns, we would need n list objects to represent the data in the table. However, we think of a table as *one* entity, not a collection of n columns. It would therefore be natural to use one argument for the whole table. This is easy to achieve using a *nested list*, where each entry in the list is a list itself. A table object, for instance, is a list of lists, either a list of the row elements of the table or a list of the column elements of the table. Here is an example where the table is a list of two columns, and each column is a list of numbers⁶:

```
Cdegrees = range(-20, 41, 5) # -20, -15, ..., 35, 40
Fdegrees = [(9.0/5)*C + 32 for C in Cdegrees]
table = [Cdegrees, Fdegrees]
```

With the subscript `table[0]` we can access the first element (the `Cdegrees` list), and with `table[0][2]` we reach the third element in the list that constitutes the first element in `table` (this is the same as `Cdegrees[2]`).

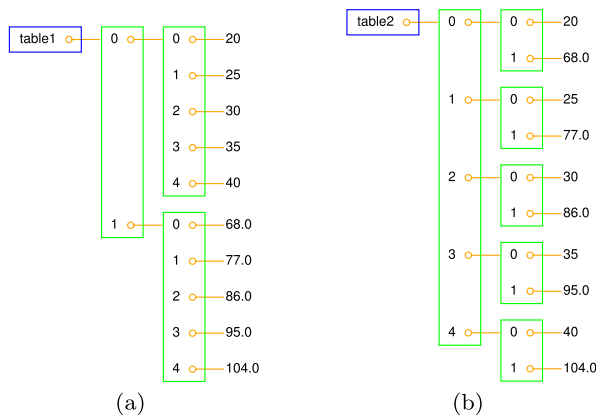

Fig. 2.2 Two ways of creating a table as a nested list: (a) table of columns C and F (C and F are lists); (b) table of rows ([C, F] lists of two floats).

However, tabular data with rows and columns usually have the convention that the underlying data is a nested list where the first index counts the rows and the second index counts the columns. To have `table` on this form, we must construct `table` as a list of [C, F] pairs. The first index will then run over rows [C, F]. Here is how we may construct the nested list:

⁶ Any value in [41, 45] can be used as second argument (stop value) to `range` and will ensure that 40 is included in the range of generate numbers.

```
table = []
for C, F in zip(Cdegrees, Fdegrees):
    table.append([C, F])
```

We may shorten this code segment by introducing a list comprehension:

```
table = [[C, F] for C, F in zip(Cdegrees, Fdegrees)]
```

This construction loops through pairs `C` and `F`, and for each pass in the loop we create a list element `[C, F]`.

The subscript `table[1]` refers to the second element in `table`, which is a `[C, F]` pair, while `table[1][0]` is the `C` value and `table[1][1]` is the `F` value. Figure 2.2 illustrates both a list of columns and a list of pairs. Using this figure, you can realize that the first index looks up the “main list”, while the second index looks up the “sublist”.

2.4.2 Printing Objects

Modules for Pretty Print of Objects. We may write `print table` to immediately view the nested list `table` from the previous section. In fact, any Python object `obj` can be printed to the screen by the command `print obj`. The output is usually one line, and this line may become very long if the list has many elements. For example, a long list like our `table` variable, demands a quite long line when printed.

```
[-20, -4.0], [-15, 5.0], [-10, 14.0], ..... , [40, 104.0]]
```

Splitting the output over several shorter lines makes the layout nicer and more readable. The `pprint` module offers a “pretty print” functionality for this purpose. The usage of `pprint` looks like

```
import pprint
pprint.pprint(table)
```

and the corresponding output becomes

```
[-20, -4.0],
[-15, 5.0],
[-10, 14.0],
[-5, 23.0],
[0, 32.0],
[5, 41.0],
[10, 50.0],
[15, 59.0],
[20, 68.0],
[25, 77.0],
[30, 86.0],
[35, 95.0],
[40, 104.0]]
```

With this book comes a slightly modified `pprint` module having the name `scitools.pprint2`. This module allows full format control of the printing of the `float` objects in lists by specifying

`scitools.pprint2.float_format` as a `printf` format string. The following example demonstrates how the output format of real numbers can be changed:

```
>>> import pprint, scitools.pprint2
>>> somelist = [15.8, [0.2, 1.7]]
>>> pprint.pprint(somelist)
[15.800000000000001, [0.20000000000000001, 1.7]]
>>> scitools.pprint2.pprint(somelist)
[15.8, [0.2, 1.7]]
>>> # default output is '%g', change this to
>>> scitools.pprint2.float_format = '%.2e'
>>> scitools.pprint2.pprint(somelist)
[1.58e+01, [2.00e-01, 1.70e+00]]
```

As can be seen from this session, the `pprint` module writes floating-point numbers with a lot of digits, in fact so many that we explicitly see the round-off errors. Many find this type of output is annoying and that the default output from the `scitools.pprint2` module is more like one would desire and expect.

The `pprint` and `scitools.pprint2` modules also have a function `pformat`, which works as the `pprint` function, but it returns a pretty formatted string rather than printing the string:

```
s = pprint.pformat(somelist)
print s
```

This last `print` statement prints the same as `pprint.pprint(somelist)`.

Manual Printing. Many will argue that tabular data such as those stored in the nested `table` list are not printed in a particularly pretty way by the `pprint` module. One would rather expect pretty output to be a table with two nicely aligned columns. To produce such output we need to code the formatting manually. This is quite easy: We loop over each row, extract the two elements `C` and `F` in each row, and print these in fixed-width fields using the `printf` syntax. The code goes as follows:

```
for C, F in table:
    print '%5d %5.1f' % (C, F)
```

2.4.3 Extracting Sublists

Python has a nice syntax for extracting parts of a list structure. Such parts are known as *sublists* or *slices*:

`A[i:]` is the sublist starting with index `i` in `A` and continuing to the end of `A`:

```
>>> A = [2, 3.5, 8, 10]
>>> A[2:]
[8, 10]
```

`A[i:j]` is the sublist starting with index `i` in `A` and continuing up to and including index `j-1`. Make sure you remember that the element corresponding to index `j` is not included in the sublist:

```
>>> A[1:3]
[3.5, 8]
```

`A[:i]` is the sublist starting with index 0 in `A` and continuing up to and including the element with index `i-1`:

```
>>> A[:3]
[2, 3.5, 8]
```

`A[1:-1]` extracts all elements except the first and the last (recall that index `-1` refers to the last element), and `A[:]` is the whole list:

```
>>> A[1:-1]
[3.5, 8]
>>> A[:]
[2, 3.5, 8, 10]
```

In nested lists we may use slices in the first index, e.g.,

```
>>> table[4:]
[[0, 32.0], [5, 41.0], [10, 50.0], [15, 59.0], [20, 68.0],
 [25, 77.0], [30, 86.0], [35, 95.0], [40, 104.0]]
```

We can also slice the second index, or both indices:

```
>>> table[4:7][0:2]
[[0, 32.0], [5, 41.0]]
```

Observe that `table[4:7]` makes a list `[[0, 32.0], [5, 41.0], [10, 50.0]]` with three elements. The slice `[0:2]` acts on this sublist and picks out its first two elements, with indices 0 and 1.

Sublists are always copies of the original list, so if you modify the sublist the original list remains unaltered and vice versa:

```
>>> l1 = [1, 4, 3]
>>> l2 = l1[:-1]
>>> l2
[1, 4]
>>> l1[0] = 100
>>> l1          # l1 is modified
[100, 4, 3]
>>> l2          # l2 is not modified
[1, 4]
```

The fact that slicing makes a copy can also be illustrated by the following code:

```
>>> B = A[:]
>>> C = A
>>> B == A
True
>>> B is A
False
>>> C is A
True
```

The `B == A` boolean expression is true if all elements in `B` are equal to the corresponding elements in `A`. The test `B is A` is true if `A` and `B` are names for the same list. Setting `C = A` makes `C` refer to the same list object as `A`, while `B = A[:]` makes `B` refer to a copy of the list referred to by `A`.

Example. We end this information on sublists by writing out the part of the `table` list of `[C, F]` rows (cf. Chapter 2.4) where the Celsius degrees are between 10 and 35 (not including 35):

```
>>> for C, F in table[Cdegrees.index(10):Cdegrees.index(35)]:
...     print '%5.0f %5.1f' % (C, F)
...
 10  50.0
 15  59.0
 20  68.0
 25  77.0
 30  86.0
```

You should always stop reading and convince yourself that you understand why a code segment produces the printed output. In this latter example, `Cdegrees.index(10)` returns the index corresponding to the value 10 in the `Cdegrees` list. Looking at the `Cdegrees` elements, one realizes (do it!) that the `for` loop is equivalent to

```
for C, F in table[6:11]:
```

This loop runs over the indices 6, 7, ..., 10 in `table`.

2.4.4 Traversing Nested Lists

We have seen that traversing the nested list `table` could be done by a loop of the form

```
for C, F in table:
    # process C and F
```

This is natural code when we know that `table` is a list of `[C, F]` lists. Now we shall address more general nested lists where we do not necessarily know how many elements there are in each list element of the list.

Suppose we use a nested list `scores` to record the scores of players in a game: `scores[i]` holds a list of the historical scores obtained by

player number i . Different players have played the game a different number of times, so the length of `scores[i]` depends on i . Some code may help to make this clearer:

```
scores = []
# score of player no. 0:
scores.append([12, 16, 11, 12])
# score of player no. 1:
scores.append([9])
# score of player no. 2:
scores.append([6, 9, 11, 14, 17, 15, 14, 20])
```

The list `scores` has three elements, each element corresponding to a player. The element $no. g$ in the list `scores[p]` corresponds to the score obtained in game number g played by player number p . The length of the lists `scores[p]` varies and equals 4, 1, and 8 for p equal to 0, 1, and 2, respectively.

In the general case we may have n players, and some may have played the game a large number of times, making `scores` potentially a big nested list. How can we traverse the `scores` list and write it out in a table format with nicely formatted columns? Each row in the table corresponds to a player, while columns correspond to scores. For example, the data initialized above can be written out as

```
12 16 11 12
 9
6  9 11 14 17 15 14 20
```

In a program, we must use two *nested loops*, one for the elements in `scores` and one for the elements in the sublists of `scores`. The example below will make this clear.

There are two basic ways of traversing a nested list: either we use integer indices for each index, or we use variables for the list elements. Let us first exemplify the index-based version:

```
for p in range(len(scores)):
    for g in range(len(scores[p])):
        score = scores[p][g]
        print '%4d' % score,
    print
```

With the trailing comma after the print string, we avoid a newline so that the column values in the table (i.e., scores for one player) appear at the same line. The single `print` command after the loop over c adds a newline after each table row. The reader is encouraged to go through the loops by hand and simulate what happens in each statement (use the simple `scores` list initialized above).

The alternative version where we use variables for iterating over the elements in the `scores` list and its sublists looks like this:

```
for player in scores:
    for game in player:
        print '%4d' % game,
    print
```

Again, the reader should step through the code by hand and realize what the values of `player` and `game` are in each pass of the loops.

In the very general case we can have a nested list with many indices: `somelist[i1][i2][i3]...` To visit each of the elements in the list, we use as many nested `for` loops as there are indices. With four indices, iterating over integer indices look as

```
for i1 in range(len(somelist)):
    for i2 in range(len(somelist[i1])):
        for i3 in range(len(somelist[i1][i2])):
            for i4 in range(len(somelist[i1][i2][i3])):
                value = somelist[i1][i2][i3][i4]
                # work with value
```

The corresponding version iterating over sublists becomes

```
for sublist1 in somelist:
    for sublist2 in sublist1:
        for sublist3 in sublist2:
            for sublist4 in sublist3:
                value = sublist4
                # work with value
```

We recommend to do Exercise [2.27](#) to get a better understanding of nested `for` loops.

2.5 Tuples

Tuples are very similar to lists, but tuples cannot be changed. That is, a tuple can be viewed as a “constant list”. While lists employ square brackets, tuples are written with standard parentheses:

```
>>> t = (2, 4, 6, 'temp.pdf')    # define a tuple with name t
```

One can also drop the parentheses in many occasions:

```
>>> t = 2, 4, 6, 'temp.pdf'
>>> for element in 'myfile.txt', 'yourfile.txt', 'herfile.txt':
...     print element,
...
myfile.txt yourfile.txt herfile.txt
```

The `for` loop here is over a tuple, because a comma separated sequence of objects, even without enclosing parentheses, becomes a tuple. Note the trailing comma in the `print` statement. This comma suppresses the final newline that the `print` command automatically adds to the output string. This is the way to make several `print` statements build up one line of output.

Much functionality for lists is also available for tuples, for example:

```
>>> t = t + (-1.0, -2.0)      # add two tuples
>>> t
(2, 4, 6, 'temp.pdf', -1.0, -2.0)
>>> t[1]                      # indexing
4
>>> t[2:]                     # subtuple/slice
(6, 'temp.pdf', -1.0, -2.0)
>>> 6 in t                    # membership
True
```

Any list operation that changes the list will not work for tuples:

```
>>> t[1] = -1
...
TypeError: object does not support item assignment

>>> t.append(0)
...
AttributeError: 'tuple' object has no attribute 'append'

>>> del t[1]
...
TypeError: object doesn't support item deletion
```

Some list methods, like `index`, are not available for tuples. So why do we need tuples when lists can do more than tuples?

- Tuples protect against accidental changes of their contents.
- Code based on tuples is faster than code based on lists.
- Tuples are frequently used in Python software that you certainly will make use of, so you need to know this data type.

There is also a fourth argument, which is important for a data type called dictionaries (introduced in Chapter 6.2): tuples can be used as keys in dictionaries while lists can not.

2.6 Summary

2.6.1 Chapter Topics

While Loops. Loops are used to repeat a collection of program statements several times. The statements that belong to the loop must be consistently indented in Python. A `while` loop runs as long as a condition evaluates to `True`:

```
>>> t = 0; dt = 0.5; T = 2
>>> while t <= T:
...     print t
...     t += dt
...
0
0.5
1.0
1.5
2.0
>>> print 'Final t:', t, '; t <= T is', t <= T
Final t: 2.5 ; t <= T is False
```

Lists. A list is used to collect a number of values or variables in an ordered sequence.

```
>>> mylist = [t, dt, T, 'mynumbers.dat', 100]
```

A list element can be any Python object, including numbers, strings, functions, and other lists, for instance. Table 2.1 shows some important list operations (only a subset of these are explained in the present chapter).

Table 2.1 Summary of important functionality for list objects.

<code>a = []</code>	initialize an empty list
<code>a = [1, 4.4, 'run.py']</code>	initialize a list
<code>a.append(elem)</code>	add <code>elem</code> object to the end
<code>a + [1,3]</code>	add two lists
<code>a.insert(i, e)</code>	insert element <code>e</code> before index <code>i</code>
<code>a[3]</code>	index a list element
<code>a[-1]</code>	get last list element
<code>a[1:3]</code>	slice: copy data to sublist (here: index 1, 2)
<code>del a[3]</code>	delete an element (index 3)
<code>a.remove(e)</code>	remove an element with value <code>e</code>
<code>a.index('run.py')</code>	find index corresponding to an element's value
<code>'run.py' in a</code>	test if a value is contained in the list
<code>a.count(v)</code>	count how many elements that have the value <code>v</code>
<code>len(a)</code>	number of elements in list <code>a</code>
<code>min(a)</code>	the smallest element in <code>a</code>
<code>max(a)</code>	the largest element in <code>a</code>
<code>sum(a)</code>	add all elements in <code>a</code>
<code>sorted(a)</code>	return sorted version of list <code>a</code>
<code>reversed(a)</code>	return reversed sorted version of list <code>a</code>
<code>b[3][0][2]</code>	nested list indexing
<code>isinstance(a, list)</code>	is <code>True</code> if <code>a</code> is a list
<code>type(a) is list</code>	is <code>True</code> if <code>a</code> is a list

Nested Lists. If the list elements are also lists, we have a nested list. The following session summarizes indexing and loop traversal of nested lists:

```
>>> n1 = [[0, 0, 1], [-1, -1, 2], [-10, 10, 5]]
>>> n1[0]
[0, 0, 1]
>>> n1[-1]
[-10, 10, 5]
>>> n1[0][2]
1
>>> n1[-1][0]
-10
>>> for p in n1:
...     print p
...
[0, 0, 1]
[-1, -1, 2]
[-10, 10, 5]
>>> for a, b, c in n1:
```

```
...     print '%3d %3d %3d' % (a, b, c)
...
    0    0    1
   -1   -1    2
  -10   10    5
```

Tuples. A tuple can be viewed as a constant list: no changes in the contents of the tuple is allowed. Tuples employ standard parentheses or no parentheses, and elements are separated with comma as in lists:

```
>>> mytuple = (t, dt, T, 'mynumbers.dat', 100)
>>> mytuple = t, dt, T, 'mynumbers.dat', 100
```

Many list operations are also valid for tuples. In Table 2.1, all operations can be applied to a tuple *a*, except those involving `append`, `del`, `remove`, `index`, and `sort`.

An object *a* containing an ordered collection of other objects such that `a[i]` refers to object with index *i* in the collection, is known as a *sequence* in Python. Lists, tuples, strings, and arrays (Chapter 5) are examples on sequences. You choose a sequence type when there is a natural ordering of elements. For a collection of unordered objects a *dictionary* (introduced in Chapter 6.2) is often more convenient.

For Loops. A `for` loop is used to run through the elements of a list or a tuple:

```
>>> for elem in [10, 20, 25, 27, 28.5]:
...     print elem,
...
10 20 25 27 28.5
```

The trailing comma after the `print` statement prevents the newline character which `print` otherwise adds to the character.

The `range` function is frequently used in `for` loops over a sequence of integers. Recall that `range(start, stop, inc)` does not include the “end value” `stop` in the list.

```
>>> for elem in range(1, 5, 2):
...     print elem,
...
1 3
>>> range(1, 5, 2)
[1, 3]
```

Implementation of a sum $\sum_{j=M}^N q(j)$, where $q(j)$ is some mathematical expression involving the integer counter j , is normally implemented using a `for` loop. Choosing, e.g., $q(j) = 1/j^2$, the sum is calculated by

```
s = 0 # accumulation variable
for j in range(M, N+1, 1):
    s += 1./j**2
```

Pretty Print. To print a list `a`, `print a` can be used, but the `pprint` and `scitools.pprint2` modules and their `pprint` function give a nicer layout of the output for long and nested lists. The `scitools.pprint2` module has the possibility to control the formatting of floating-point numbers.

Terminology. The important computer science terms in this chapter are

- list,
- tuple,
- nested list (and nested tuple),
- sublist (subtuple) or slice,
- while loop,
- for loop,
- list comprehension,
- boolean expression.

2.6.2 Example: Analyzing List Data

Problem. The file `src/misc/Oxford_sun_hours.txt` contains data of the number of sun hours in Oxford, UK, for every month since January 1929. The data are already on a suitable nested list format⁷:

```
[
  [43.8, 60.5, 190.2, ...],
  [49.9, 54.3, 109.7, ...],
  [63.7, 72.0, 142.3, ...],
  ]''
```

The list in every line holds the number of sun hours for each of the year's 12 months. That is, the first index in the nested list corresponds to year and the second index corresponds to the month number. More precisely, the double index `[i][j]` corresponds to year $1929 + i$ and month $1 + j$ (January being month number 1).

The task is to define this nested list in a program and do the following data analysis.

1. Compute the average number of sun hours for each month during the total data period (1929–2009).
2. Which month has the best weather according to the means found in the preceding task?
3. For each decade, 1930–1939, 1949–1949, ..., 2000–2009, compute the average number of sun hours per day in January and December. For example, use December 1949, January 1950, ..., December 1958, and January 1959 as data for the decade 1950–1959. Are there any noticeable differences between the decades?

⁷ Actually, the data are taken from a web page as explained in Chapter 6.4.3 and easily written out in the list format shown here.

Solution. Initializing the data is easy: just copy the data from the `Oxford_sun_hours.txt` file into the program file and set a variable name on the left hand side (the long and wide code is only indicated here):

```
data = [
[43.8, 60.5, 190.2, ...],
[49.9, 54.3, 109.7, ...],
[63.7, 72.0, 142.3, ...],
...
]
```

For task 1, we need to establish a list `monthly_mean` with the results from the computation, i.e., `monthly_mean[2]` holds the average number of sun hours for March in the period 1929–2009. The average is computed in the standard way: for each month, we run through all the years, sum up the values, and finally divide by the number of years ($2009 - 1929 + 1$).

When looping over years and months it is convenient to have loop variables running over the true years (1929 to 2009) and the standard month number (1 to 12). These variables must be correctly translated to indices in the `data` list such that all indices start at 0. The following code produces the answers to task 1:

```
monthly_mean = [0]*12      # list with 12 elements
for month in range(1, 13):
    m = month - 1          # corresponding list index (starts at 0)
    s = 0                  # sum
    n = 2009 - 1929 + 1    # no of years
    for year in range(1929, 2010):
        y = year - 1929    # corresponding list index (starts at 0)
        s += data[y][m]
    monthly_mean[m] = s/n
```

An alternative solution would be to introduce separate variables for the monthly averages, say `Jan_mean`, `Feb_mean`, etc. The reader should as an exercise write the code associated with such a solution and realize that using the `monthly_mean` list is more elegant and yields much simpler and shorter code. Separate variables might be an okay solution for 2–3 variables, but as many as 12.

Perhaps we want a nice-looking printout of the results. This can elegantly be created by first defining a tuple (or list) of the names of the months and then running through this list in parallel with `monthly_mean`:

```
month_names = 'Jan', 'Feb', 'Mar', 'Apr', 'May', 'Jun', \
              'Jul', 'Aug', 'Sep', 'Oct', 'Nov', 'Dec'
for name, value in zip(month_names, monthly_mean):
    print '%s: %.1f' % (name, value)
```

The printout becomes

```
Jan: 55.9
Feb: 71.8
Mar: 115.1
Apr: 151.3
```

```

May: 188.7
Jun: 196.1
Jul: 191.4
Aug: 182.1
Sep: 136.7
Oct: 103.4
Nov: 66.6
Dec: 51.7

```

Task 2 can be solved by pure inspection of the above printout, which reveals that June is the winner. However, since we are learning programming, we should be able to replace our eyes with some computer code to automate the task. The maximum value `max_value` of a list like `monthly_mean` is simply obtained by `max(monthly_mean)`. The corresponding index, needed to find the right name of the corresponding month, is found from `monthly_mean.index(max_value)`. The code for task 2 is then

```

max_value = max(monthly_mean)
month = month_names[monthly_mean.index(max_value)]
print '%s has best weather with %.1f sun hours on average' % \
      (month, max_value)

```

(Instead of using the Python's `max` and `index` functionality, we could code everything ourselves to get some training, see Exercise 3.22 for ideas.)

Task 3 requires us to first develop an algorithm for how to compute the decade averages. The algorithm, expressed with words, goes as follows. We loop over the decades, and for each decade, we loop over its years, and for each year, we add the December data of the previous year and the January data of the current year to an accumulation variable. Dividing this accumulation variable by $10 \cdot 2 \cdot 30$ gives the average number of sun hours per day in the winter time for the particular decade. The code segment below expresses this algorithm in the Python language:

```

decade_mean = []
for decade_start in range(1930, 2010, 10):
    Jan_index = 0; Dec_index = 11 # indices
    s = 0
    for year in range(decade_start, decade_start+10):
        y = year - 1929 # list index
        print data[y-1][Dec_index] + data[y][Jan_index]
        s += data[y-1][Dec_index] + data[y][Jan_index]
    decade_mean.append(s/(20.*30))
for i in range(len(decade_mean)):
    print 'Decade %d-%d: %.1f' % \
          (1930+i*10, 1939+i*10, decade_mean[i])

```

The output becomes

```

Decade 1930-1939: 1.7
Decade 1940-1949: 1.8
Decade 1950-1959: 1.8
Decade 1960-1969: 1.8
Decade 1970-1979: 1.6
Decade 1980-1989: 2.0

```

Decade 1990–1999: 1.8
 Decade 2000–2009: 2.1

The complete code is found in the file `sun_data.py`.

2.6.3 How to Find More Python Information

This book contains only fragments of the Python language. When doing your own projects or exercises you will certainly feel the need for looking up more detailed information on modules, objects, etc. Fortunately, there is a lot of excellent documentation on the Python programming language.

The primary reference is the [official Python documentation website: docs.python.org](https://docs.python.org). Here you can find a Python tutorial, the very useful *Python Library Reference*, an index of all modules that come with the basic Python distribution, and a *Language Reference*, to mention some key documents. You should in particular discover the [index](#) of the Python Library Reference. When you wonder what functions you can find in a module, say the `math` module, you should go to this index, find the “math” keyword, and press the link. This brings you right to the official documentation of the `math` module. Similarly, if you want to look up more details of the `printf` formatting syntax, go to the index and follow the “printf-style formatting” index.

A word of caution is probably necessary here. Reference manuals, such as the Python Library Reference, are very technical and written primarily for experts, so it can be quite difficult for a newbie to understand the information. An important ability is to browse such manuals and dig out the key information you are looking for, without being annoyed by all the text you do not understand. As with programming, reading manuals efficiently requires a lot of training.

A tool somewhat similar to the Python Library Reference is the `pydoc` program. In a terminal window you write

Terminal

```
Terminal> pydoc math
```

In Python there are two possibilities, either⁸

```
In [1]: !pydoc math
```

or

```
In [2]: import math
In [3]: help(math)
```

⁸ Any command you can run in the terminal window can also be run inside IPython if you start the command with an exclamation mark.

The documentation of the complete `math` module is shown as plain text. If a specific function is wanted, we can ask for that directly, e.g., `pydoc math.tan`. Since `pydoc` is very fast, many prefer `pydoc` over web pages, but `pydoc` has often less information compared to the Python Library Reference.

There are also numerous books about Python. Beazley [1] is an excellent reference that improves and extends the information in the Python Library Reference. The “Learning Python” book [8] has been very popular for many years as an introduction to the language. There is a special web page <http://wiki.python.org/moin/PythonBooks> listing most Python books on the market. A comprehensive book on the use of Python for doing scientific research is [5].

Quick references, which list “all” Python functionality in compact tabular form, are very handy. We recommend in particular the one by Richard Gruet: <http://rgruet.free.fr/#QuickRef>.

The website <http://www.python.org/doc/> contains a list of useful Python introductions and reference manuals.

2.7 Exercises

Exercise 2.1. *Make a Fahrenheit–Celsius conversion table.*

Write a program that prints out a table with Fahrenheit degrees 0, 10, 20, . . . , 100 in the first column and the corresponding Celsius degrees in the second column. Hint: Modify the `c2f_table_while.py` program from Chapter 2.1.2. Name of program file: `f2c_table_while.py`.
◇

Exercise 2.2. *Write an approximate Fahrenheit–Celsius conversion table.*

Many people use an approximate formula for quickly converting Fahrenheit (F) to Celsius (C) degrees:

$$C \approx \hat{C} = (F - 30)/2 \quad (2.2)$$

Modify the program from Exercise 2.1 so that it prints three columns: F , C , and the approximate value \hat{C} . Name of program file: `f2c_approx_table.py`.
◇

Exercise 2.3. *Generate odd numbers.*

Write a program that generates all odd numbers from 1 to n . Set n in the beginning of the program and use a `while` loop to compute the numbers. (Make sure that if n is an even number, the largest generated odd number is $n-1$.) Name of program file: `odd.py`.
◇

Exercise 2.4. *Store odd numbers in a list.*

Modify the program from Exercise 2.3 to store the generated odd numbers in a list. Start with an empty list and use a `while` loop

where you in each pass of the loop append a new element to the list. Finally, print the list elements to the screen. Name of program file: `odd_list1.py`. ◇

Exercise 2.5. *Generate odd numbers by a list comprehension.*

Solve Exercise 2.4 using a list comprehension (with `for` and `range`). Name of program file: `odd_list2.py`. ◇

Exercise 2.6. *Make a table of values from a formula.*

Write a program that prints a nicely formatted table of t and $y(t)$ values, where

$$y(t) = v_0 t - \frac{1}{2} g t^2.$$

Use n uniformly spaced t values throughout the interval $[0, 2v_0/g]$. Set $v_0 = 1$ and $n = 11$. Name of program file: `ball_table1.py`. ◇

Exercise 2.7. *Store values from a formula in lists.*

Modify the program from Exercise 2.6 so that the t and y values are stored in two lists `t` and `y`. Thereafter, transverse the lists with a `for` loop and write out a nicely formatted table of t and y values (using either a `zip` or `range` construction). Set $v_0 = 10$ and $n = 81$. Name of program file: `ball_table2.py`. ◇

Exercise 2.8. *Work with a list.*

Set a variable `primes` to a list containing the numbers 2, 3, 5, 7, 11, and 13. Write out each list element in a `for` loop. Assign 17 to a variable `p` and add `p` to the end of the list. Print out the whole new list. Name of program file: `primes.py`. ◇

Exercise 2.9. *Simulate operations on lists by hand.*

You are given the following program:

```
a = [1, 3, 5, 7, 11]
b = [13, 17]
c = a + b
print c
b[0] = -1
d = [e+1 for e in a]
print d
d.append(b[0] + 1)
d.append(b[-1] + 1)
print d[-2:]
```

Go through each statement and explain what is printed by the program. ◇

Exercise 2.10. *Generate equally spaced coordinates.*

We want to generate x coordinates between 1 and 2 with spacing 0.01. The coordinates are given by the formula $x_i = 1 + ih$, where $h = 0.01$ and i runs over integers $0, 1, \dots, 100$. Compute the x_i values and store them in a list (use a `for` loop, and append each new x_i value to a list, which is empty initially). Name of program file: `coor1.py`. ◇

Exercise 2.11. Use a list comprehension to solve Exer. 2.10.

The problem is the same as in Exercise 2.10, but now we want the x_i values to be stored in a list using a list comprehension construct (see Chapter 2.3.5). Name of program file: `coor2.py`. \diamond

Exercise 2.12. Compute a mathematical sum.

The following code is supposed to compute the sum $s = \sum_{k=1}^M \frac{1}{k}$:

```
s = 0; k = 1; M = 100
while k < M:
    s += 1/k
print s
```

This program does not work correctly. What are the three errors? (If you try to run the program, nothing will happen on the screen. Type `Ctrl-C`, i.e., hold down the Control (`Ctrl`) key and then type the `c` key, to stop a program.) Write a correct program. Name of program file: `sum_while.py`.

There are two basic ways to find errors in a program: (i) read the program carefully and think about the consequences of each statement, and (ii) print out intermediate results and compare with hand calculations. First, try method (i) and find as many errors as you can. Then, try method (ii) for $M = 3$ and compare the evolution of `s` with your own hand calculations. \diamond

Exercise 2.13. Use a for loop in Exer. 2.12.

Rewrite the corrected version of the program in Exercise 2.12 using a for loop over `k` values instead of a while loop. Name of program file: `sum_for.py`. \diamond

Exercise 2.14. Simulate a program by hand.

Consider the following program for computing with interest rates:

```
initial_amount = 100
p = 5.5 # interest rate
amount = initial_amount
years = 0
while amount <= 1.5*initial_amount:
    amount = amount + p/100*amount
    years = years + 1
print years
```

Explain with words what type of mathematical problem that is solved by this program. Compare this computerized solution with the technique your high school math teacher would prefer.

Use a pocket calculator (or use an interactive Python shell as substitute) and work through the program by hand. Write down the value of `amount` and `years` in each pass of the loop.

Change the value of `p` to 5. Why will the loop now run forever? (See Exercise 2.12 for how to stop the program if you try to run it.) Make the program more robust against such errors.

Make use of the operator += wherever possible in the program.

Insert the text for the answers to (a) and (b) in a multi-line string in the program file. Name of program file: `interest_rate_loop.py`. ◇

Exercise 2.15. *Explore the Python Library Reference.*

Suppose you want to compute the inverse sine function: $\sin^{-1} x$. The `math` module has a function for computing $\sin^{-1} x$, but what is the right name of this function? Read Chapter 2.6.3 and use the `math` entry in the index of the Python Library Reference to find out how to compute $\sin^{-1} x$. Make a program where you compute $\sin^{-1} x$ for n x values uniformly distributed between 0 and 1, and write out the results in a nicely formatted table. For each x value, check that the sine of $\sin^{-1} x$ equals x . Name of program file: `inverse_sine.py`. ◇

Exercise 2.16. *Index a nested lists.*

We define the following nested list:

```
q = [['a', 'b', 'c'], ['d', 'e', 'f'], ['g', 'h']]
```

Index this list to extract 1) the letter a; 2) the list `['d', 'e', 'f']`; 3) the last element h; 4) the d element. Explain why `q[-1][-2]` has the value g. Name of program file: `index_nested_list.py`. ◇

Exercise 2.17. *Construct a double for loop over a nested list.*

Consider the list from Exercise 2.16. We can visit all elements of `q` using this nested for loop:

```
for i in q:
    for j in range(len(i)):
        print i[j]
```

What type of objects are `i` and `j`? Name of program file: `nested_list_iter.py`. ◇

Exercise 2.18. *Store data in lists in Exercise 2.2.*

Modify the program from Exercise 2.2 so that all the F , C , and \hat{C} values are stored in separate lists `F`, `C`, and `C_approx`, respectively. Then make a nested list `conversion` so that `conversion[i]` holds a row in the table: `[F[i], C[i], C_approx[i]]`. Finally, let the program traverse the `conversion` list and write out the same table as in Exercise 2.2. Name of program file: `f2c_approx_lists.py`. ◇

Exercise 2.19. *Store data from Exer. 2.7 in a nested list.*

After having computed the two lists of t and y values in the program from Exercise 2.7, store the two lists in a new list `ty1`. Write out a table of t and y values by traversing the data in the `ty1` list. Thereafter, make a list `ty2` which holds each row in the table of t and y values (`ty1` is a list of table columns while `ty2` is a list of table rows, as explained in Chapter 2.4). Write out the table by traversing the `ty2` list. Name of program file: `ball_table3.py`. ◇

Exercise 2.20. *Convert nested list comprehensions to nested standard loops.*

Rewrite the generation of the nested list `q`,

```
q = [r**2 for r in [10**i for i in range(5)]]
```

by using standard `for` loops instead of list comprehensions. Name of program file: `listcomp2for.py`. ◇

Exercise 2.21. *Values of boolean expressions.*

Explain the outcome of each of the following boolean expressions:

```
C = 41
C == 40
C != 40 and C < 41
C != 40 or C < 41
not C == 40
not C > 40
C <= 41
not False
True and False
False or True
False or False or False
True and True and False
False == 0
True == 0
True == 1
```

Note: It makes sense to compare `True` and `False` to the integers 0 and 1, but not other integers (e.g., `True == 12` is `False` although the *integer* 12 evaluates to `True` in a boolean context, as in `bool(12)` or `if 12`). ◇

Exercise 2.22. *Explore round-off errors from a large number of inverse operations.*

Maybe you have tried to hit the square root key on a calculator multiple times and then squared the number again an equal number of times. These set of inverse mathematical operations should of course bring you back to the starting value for the computations, but this does not always happen. To avoid tedious pressing of calculator keys we can let a computer automate the process. Here is an appropriate program:

```
from math import sqrt
for n in range(1, 60):
    r = 2.0
    for i in range(n):
        r = sqrt(r)
    for i in range(n):
        r = r**2
    print '%d times sqrt and **2: %.16f' % (n, r)
```

Explain with words what the program does. Then run the program. Round-off errors are here completely destroying the calculations when `n` is large enough! Investigate the case when we come back to 1 instead of 2 by fixing the `n` value and printing out `r` in both `for` loops over `i`.

Can you now explain why we come back to 1 and not 2? Name of program file: `repeated_sqrt.py`. ◇

Exercise 2.23. *Explore what zero can be on a computer.*

Type in the following code and run it:

```
eps = 1.0
while 1.0 != 1.0 + eps:
    print '.....', eps
    eps = eps/2.0
print 'final eps:', eps
```

Explain with words what the code is doing, line by line. Then examine the output. How can it be that the “equation” $1 \neq 1 + \text{eps}$ is not true? Or in other words, that a number of approximately size 10^{-16} (the final `eps` value when the loop terminates) gives the same result as if `eps`⁹ were zero? Name of program file: `machine_zero.py`.

If somebody shows you this interactive session

```
>>> 0.5 + 1.45E-22
0.5
```

and claims that Python cannot add numbers correctly, what is your answer? ◇

Exercise 2.24. *Compare two real numbers on a computer.*

Consider the following simple program inspired by Chapter 1.4.3:

```
a = 1/947.0*947
b = 1
if a != b:
    print 'Wrong result!'
```

Try to run this example!

One should never compare two floating-point objects directly using `==` or `!=`, because round-off errors quickly make two identical mathematical values different on a computer. A better result is to test if $|a - b|$ is sufficiently small, i.e., if a and b are “close enough” to be considered equal. Modify the test according to this idea.

Thereafter, read the documentation of the function `float_eq` from SciTools: `scitools.std.float_eq` (see page 78 for how to bring up the documentation of a module or a function in a module). Use this function to check whether two real numbers are equal within a tolerance. Name of program file: `compare_float.py`. ◇

Exercise 2.25. *Interpret a code.*

The function `time` in the module `time` returns the number of seconds since a particular date (called the Epoch, which is January 1,

⁹ This nonzero `eps` value is called *machine epsilon* or *machine zero* and is an important parameter to know, especially when certain mathematical techniques are applied to control round-off errors.

1970, on many types of computers). Python programs can therefore use `time.time()` to mimic a stop watch. Another function, `time.sleep(n)` causes the program to “sleep” for `n` seconds and is handy for inserting a pause. Use this information to explain what the following code does:

```
import time
t0 = time.time()
while time.time() - t0 < 10:
    print '...I like while loops!'
    time.sleep(2)
print 'Oh, no - the loop is over.'
```

How many times is the `print` statement inside the loop executed? Now, copy the code segment and change the `<` sign in the loop condition to a `>` sign. Explain what happens now. Name of program: `time_while.py`.
◇

Exercise 2.26. *Explore problems with inaccurate indentation.*

Type in the following program in a file and check carefully that you have exactly the same spaces:

```
C = -60; dC = 2
while C <= 60:
    F = (9.0/5)*C + 32
    print C, F
C = C + dC
```

Run the program. What is the first problem? Correct that error. What is the next problem? What is the cause of that problem? (See Exercise 2.12 for how to stop a hanging program.)

The lesson learned from this exercise is that one has to be very careful with indentation in Python programs! Other computer languages usually enclose blocks belonging to loops in curly braces, parentheses, or BEGIN-END marks. Python’s convention with using solely indentation contributes to visually attractive, easy-to-read code, at the cost of requiring a pedantic attitude to blanks from the programmer. ◇

Exercise 2.27. *Simulate nested loops by hand.*

Go through the code below by hand, statement by statement, and calculate the numbers that will be printed.

```
n = 3
for i in range(-1, n):
    if i != 0:
        print i

for i in range(1, 13, 2*n):
    for j in range(n):
        print i, j

for i in range(1, n+1):
    for j in range(i):
        if j:
            print i, j
```

```

for i in range(1, 13, 2*n):
    for j in range(0, i, 2):
        for k in range(2, j, 1):
            b = i > j > k
            if b:
                print i, j, k

```

You may use a debugger, see Appendix F.1, to see what happens when you step through the code. ◇

Exercise 2.28. *Explore punctuation in Python programs.*

Some of the following assignments work and some do not. Explain in each case why the assignment works/fails and, if it works, what kind of object `x` refers to and what the value is if we do a `print x`.

```

x = 1
x = 1.
x = 1;
x = 1!
x = 1?
x = 1:
x = 1,

```

Hint: Explore the statements in an interactive Python shell. ◇

Exercise 2.29. *Investigate a for loop over a changing list.*

Study the following interactive session and explain in detail what happens in each pass of the loop, and use this explanation to understand the output.

```

>>> numbers = range(10)
>>> print numbers
[0, 1, 2, 3, 4, 5, 6, 7, 8, 9]
>>> for n in numbers:
...     i = len(numbers)/2
...     del numbers[i]
...     print 'n=%d, del %d' % (n,i), numbers
...
n=0, del 5 [0, 1, 2, 3, 4, 6, 7, 8, 9]
n=1, del 4 [0, 1, 2, 3, 6, 7, 8, 9]
n=2, del 4 [0, 1, 2, 3, 7, 8, 9]
n=3, del 3 [0, 1, 2, 7, 8, 9]
n=8, del 3 [0, 1, 2, 8, 9]

```

The message in this exercise is to *never modify a list that is used in a for loop*. Modification is indeed technically possible, as we show above, but you really need to know what you are doing – to avoid getting frustrated by strange program behavior. ◇

This chapter introduces two fundamental and extremely useful concepts in programming: user-defined functions and branching of program flow, the latter often referred to as “if tests”. The programs associated with the chapter are found in `src/funcif`.

3.1 Functions

In a computer language like Python, the term *function* means more than just a mathematical function. A function is a collection of statements that you can execute wherever and whenever you want in the program. You may send variables to the function to influence what is getting computed by statements in the function, and the function may return new objects. In particular, functions help to avoid duplicating code snippets by putting all similar snippets in a common place. This strategy saves typing and makes it easier to change the program later. Functions are also often used to just split a long program into smaller, more manageable pieces, so the program and your own thinking about it become clearer. Python comes with lots of functions (`math.sqrt`, `range`, and `len` are examples we have met so far). This section outlines how you can define your own functions.

3.1.1 Functions of One Variable

Let us start with making a Python function that evaluates a mathematical function, more precisely the function $F(C)$ defined in (1.2): $F(C) = \frac{9}{5}C + 32$. The corresponding Python function must take C as argument and return the value $F(C)$. The code for this looks like

```
def F(C):
    return (9.0/5)*C + 32
```

All Python functions begin with `def`, followed by the function name, and then inside parentheses a comma-separated list of *function arguments*. Here we have only one argument `C`. This argument acts as a standard variable inside the function. The statements to be performed inside the function must be indented. At the end of a function it is common to *return* a value, that is, send a value “out of the function”. This value is normally associated with the name of the function, as in the present case where the returned value is $F(C)$.

The `def` line with the function name and arguments is often referred to as the *function header*, while the indented statements constitute the *function body*.

To use a function, we must *call*¹ it. Because the function returns a value, we need to store this value in a variable or make use of it in other ways. Here are some calls to `F`:

```
a = 10
F1 = F(a)
temp = F(15.5)
print F(a+1)
sum_temp = F(10) + F(20)
```

The returned object from `F(C)` is in our case a `float` object. The call `F(C)` can therefore be placed anywhere in a code where a `float` object would be valid. The `print` statement above is one example. As another example, say we have a list `Cdegrees` of Celsius degrees and we want to compute a list of the corresponding Fahrenheit degrees using the `F` function above in a list comprehension:

```
Fdegrees = [F(C) for C in Cdegrees]
```

As an example of a slight variation of our `F(C)` function, we may return a formatted string instead of a real number:

```
>>> def F2(C):
...     F_value = (9.0/5)*C + 32
...     return '%.1f degrees Celsius corresponds to '\
...           '%.1f degrees Fahrenheit' % (C, F_value)
...
>>> s1 = F2(21)
>>> s1
'21.0 degrees Celsius corresponds to 69.8 degrees Fahrenheit'
```

The assignment to `F_value` demonstrates that we can create variables inside a function as needed.

¹ Sometimes the word *invoke* is used as an alternative to *call*.

3.1.2 Local and Global Variables

Let us reconsider the `F2(C)` function from the previous section. The variable `F_value` is a *local* variable in the function, and a local variable does not exist outside the function. We can easily demonstrate this fact by continuing the previous interactive session:

```
>>> c1 = 37.5
>>> s2 = F2(c1)
>>> F_value
...
NameError: name 'F_value' is not defined
```

The surrounding program outside the function is not aware of `F_value`. Also the argument to the function, `C`, is a local variable that we cannot access outside the function:

```
>>> C
...
NameError: name 'C' is not defined
```

On the contrary, the variables defined outside of the function, like `s1`, `s2`, and `c1` in the above session, are *global* variables. These can be accessed everywhere in a program.

Local variables are created inside a function and destroyed when we leave the function. To learn more about this fact, we may study the following session where we write out `F_value`, `C`, and some global variable `r` inside the function:

```
>>> def F3(C):
...     F_value = (9.0/5)*C + 32
...     print 'Inside F3: C=%s F_value=%s r=%s' % (C, F_value, r)
...     return '%.1f degrees Celsius corresponds to '\
...           '%.1f degrees Fahrenheit' % (C, F_value)
...
>>> C = 60      # make a global variable C
>>> r = 21      # another global variable
>>> s3 = F3(r)
Inside F3: C=21 F_value=69.8 r=21
>>> s3
'21.0 degrees Celsius corresponds to 69.8 degrees Fahrenheit'
>>> C
60
```

This example illustrates that there are two `C` variables, one global, defined in the main program with the value 60 (an `int` object), and one local, living when the program flow is inside the `F3` function. The value of this `C` is given in the call to the `F3` function (also an `int` object in this case). Inside the `F3` function the local `C` “hides” the global `C` variable in the sense that when we refer to `C` we access the local variable².

The more general rule, when you have several variables with the same name, is that Python first tries to look up the variable name among

² The global `C` can technically be accessed as `globals()['C']`, but one should avoid working with local and global variables with the same names at the same time!

the local variables, then there is a search among global variables, and finally among built-in Python functions. Here is a complete sample program with several versions of a variable `sum` which aims to illustrate this rule:

```
print sum # sum is a built-in Python function
sum = 500 # rebind the name sum to an int
print sum # sum is a global variable

def myfunc(n):
    sum = n + 1
    print sum # sum is a local variable
    return sum

sum = myfunc(2) + 1 # new value in global variable sum
print sum
```

In the first line, there are no local variables, so Python searches for a global value with name `sum`, but cannot find any, so the search proceeds with the built-in functions, and among them Python finds a function with name `sum`. The printout of `sum` becomes something like `<built-in function sum>`.

The second line rebinds the global name `sum` to an `int` object. When trying to access `sum` in the next `print` statement, Python searches among the global variables (no local variables so far) and finds one. The printout becomes `500`. The call `myfunc(2)` invokes a function where `sum` is a local variable. Doing a `print sum` in this function makes Python first search among the local variables, and since `sum` is found there, the printout becomes `3` (and not `500`, the value of the global variable `sum`). The value of the local variable `sum` is returned, added to `1`, to form an `int` object with value `4`. This `int` object is then bound to the global variable `sum`. The final `print sum` leads to a search among global variables, and we find one with value `4`.

The values of global variables can be accessed inside functions, but the values cannot be changed unless the variable is declared as `global`:

```
a = 20; b = -2.5 # global variables

def f1(x):
    a = 21 # this is a new local variable
    return a*x + b # 21*x - 2.5

print a # yields 20

def f2(x):
    global a
    a = 21 # the global a is changed
    return a*x + b # 21*x - 2.5

f1(3); print a # 20 is printed
f2(3); print a # 21 is printed
```

Note that in the `f1` function, `a = 21` creates a local variable `a`. As a programmer you may think you change the global `a`, but it does not

happen! Normally, this feature is advantageous because changing global variables often leads to errors in programs.

3.1.3 Multiple Arguments

The previous `F(C)` and `F2(C)` functions are functions of one variable, `C`, or as we phrase it in computer science: the functions take one argument (`C`). Functions can have as many arguments as desired; just separate the argument names by commas.

Consider the function

$$y(t) = v_0 t - \frac{1}{2} g t^2.$$

A possible Python implementation is a function with two arguments:

```
def yfunc(t, v0):  
    g = 9.81  
    return v0*t - 0.5*g*t**2
```

Note that `g` is a local variable with a fixed value, while `t` and `v0` are arguments and therefore also local variables. Examples on valid calls are

```
y = yfunc(0.1, 6)  
y = yfunc(0.1, v0=6)  
y = yfunc(t=0.1, v0=6)  
y = yfunc(v0=6, t=0.1)
```

The possibility to write `argument=value` in the call makes it easier to read and understand the call statement. With the `argument=value` syntax for all arguments, the sequence of the arguments does not matter in the call, which here means that we may put `v0` before `t`. When omitting the `argument=` part, the sequence of arguments in the call must perfectly match the sequence of arguments in the function definition. The `argument=value` arguments must appear after all the arguments where only `value` is provided (e.g., `yfunc(t=0.1, 6)` is illegal).

Whether we write `yfunc(0.1, 6)` or `yfunc(v0=6, t=0.1)`, the arguments are initialized as local variables in the function in the same way as when we assign values to variables:

```
t = 0.1  
v0 = 6
```

These statements are not visible in the code, but a call to a function automatically initializes the arguments in this way.

Some may argue that `yfunc` should be a function of `t` only, because we mathematically think of y as a function of t and write $y(t)$. This is easy to reflect in Python:

```
def yfunc(t):
    g = 9.81
    return v0*t - 0.5*g*t**2
```

The main difference is that `v0` now must be a *global* variable, which needs to be initialized before we call `yfunc`. The next session demonstrates what happens if we fail to initialize such a global variable:

```
>>> def yfunc(t):
...     g = 9.81
...     return v0*t - 0.5*g*t**2
...
>>> yfunc(0.6)
...
NameError: global name 'v0' is not defined
```

The remedy is to define `v0` as a global variable prior to calling `yfunc`:

```
>>> v0 = 5
>>> yfunc(0.6)
1.2342
```

So far our Python functions have typically computed some mathematical function, but the usefulness of Python functions goes far beyond mathematical functions. Any set of statements that we want to repeatedly execute under slightly different circumstances is a candidate for a Python function. Say we want to make a list of numbers starting from some value and stopping at another value, with increments of a given size. With corresponding variables `start=2`, `stop=8`, and `inc=2`, we should produce the numbers 2, 4, 6, and 8. Our tables in this chapter typically needs such functionality for creating a list of C values or a list of t values. Let us therefore write a function doing the task³, together with a couple of statements that demonstrate how we call the function:

```
def makelist(start, stop, inc):
    value = start
    result = []
    while value <= stop:
        result.append(value)
        value = value + inc
    return result

mylist = makelist(0, 100, 0.2)
print mylist # will print 0, 0.2, 0.4, 0.6, ... 99.8, 100
```

The `makelist` function has three arguments: `start`, `stop`, and `inc`, which become local variables in the function. Also `value` and `result` are local variables. In the surrounding program we define only one variable, `mylist`, and this is then a global variable.

³ You might think that `range(start, stop, inc)` makes the `makelist` function redundant, but `range` can only generate integers, while `makelist` can generate real numbers too – and more, see Exercise 3.38.

3.1.4 Multiple Return Values

Python functions may return more than one value. Suppose we are interested in evaluating both $y(t)$ and $y'(t)$:

$$y(t) = v_0t - \frac{1}{2}gt^2,$$

$$y'(t) = v_0 - gt.$$

In the current application where $y(t)$ is the vertical position of a ball thrown up in the air, $y'(t)$ is the ball's velocity. To return both y and y' we simply separate their corresponding variables by a comma in the `return` statement:

```
def yfunc(t, v0):
    g = 9.81
    y = v0*t - 0.5*g*t**2
    dydt = v0 - g*t
    return y, dydt
```

When we call this latter `yfunc` function, we need two values on the left-hand side of the assignment operator because the function returns two values:

```
position, velocity = yfunc(0.6, 3)
```

Here is an application of the `yfunc` function for producing a nicely formatted table of positions and velocities of a ball thrown up in the air:

```
t_values = [0.05*i for i in range(10)]
for t in t_values:
    pos, vel = yfunc(t, v0=5)
    print 't=%-10g position=%-10g velocity=%-10g' % (t, pos, vel)
```

The format `%-10g` prints a real number as compactly as possible (decimal or scientific notation) in a field of width 10 characters. The minus (“-”) sign after the percentage sign implies that the number is *left-adjusted* in this field, a feature that is important for creating nice-looking columns in the output:

t=0	position=0	velocity=5
t=0.05	position=0.237737	velocity=4.5095
t=0.1	position=0.45095	velocity=4.019
t=0.15	position=0.639638	velocity=3.5285
t=0.2	position=0.8038	velocity=3.038
t=0.25	position=0.943437	velocity=2.5475
t=0.3	position=1.05855	velocity=2.057
t=0.35	position=1.14914	velocity=1.5665
t=0.4	position=1.2152	velocity=1.076
t=0.45	position=1.25674	velocity=0.5855

When a function returns multiple values, separated by a comma in the `return` statement, a tuple (Chapter 2.5) is actually returned. We can demonstrate that fact by the following session:

```

>>> def f(x):
...     return x, x**2, x**4
...
>>> s = f(2)
>>> s
(2, 4, 16)
>>> type(s)
<type 'tuple'>
>>> x, x2, x4 = f(2)

```

Note that storing multiple return values into separate variables, as we do in the last line, is actually the same functionality as we use for storing list elements in separate variables, see on page 57.

Our next example concerns a function aimed at calculating the sum

$$L(x; n) = \sum_{i=1}^n \frac{1}{i} \left(\frac{x}{1+x} \right)^i. \quad (3.1)$$

It can be shown that $L(x; n)$ is an approximation to $\ln(1+x)$ for a finite n and $x \geq 1$. The approximation becomes exact in the limit:

$$\ln(1+x) = \lim_{n \rightarrow \infty} L(x; n).$$

To compute a sum in a Python program, we always use a loop and add terms to an accumulation variable inside the loop. Chapter 2.1.4 explains the idea. However, summation expressions with an integer counter, such as i in (3.1), are normally implemented by a `for` loop over the i counter and not a `while` loop as in Chapter 2.1.4. For example, the implementation of $\sum_{i=1}^n c(i)$, where $c(i)$ is some formula depending on i , is typically implemented as

```

s = 0
for i in range(1, n+1):
    s += c(i)

```

For the specific sum (3.1) we just replace $c(i)$ by the right term $(1/i)(x/(1+x))^i$ inside the `for` loop⁴:

```

s = 0
for i in range(1, n+1):
    s += (1.0/i)*(x/(1.0+x))**i

```

It is natural to embed the computation of the sum in a function which takes x and n as arguments and returns the sum:

```

def L(x, n):
    s = 0
    for i in range(1, n+1):
        s += (1.0/i)*(x/(1.0+x))**i
    return s

```

Instead of just returning the value of the sum, we could return additional information on the error involved in the approximation of

⁴ Observe the 1.0 numbers: These avoid integer division (i is `int` and x may be `int`).

$\ln(1+x)$ by $L(x;n)$. The first neglected term in the sum provides an indication of the error⁵. We could also return the exact error. The new version of the $L(x, n)$ function then looks as this:

```
def L(x, n):
    s = 0
    for i in range(1, n+1):
        s += (1.0/i)*(x/(1.0+x))**i
    value_of_sum = s
    first_neglected_term = (1.0/(n+1))*(x/(1.0+x))**(n+1)
    from math import log
    exact_error = log(1+x) - value_of_sum
    return value_of_sum, first_neglected_term, exact_error

# typical call:
value, approximate_error, exact_error = L2(x, 100)
```

The next section demonstrates the usage of the L function to judge the quality of the approximation $L(x;n)$ to $\ln(1+x)$.

3.1.5 Functions with No Return Values

Sometimes a function just performs a set of statements, and it is not natural to return any values to the calling code. In such situations one can simply skip the `return` statement. Some programming languages use the terms procedure or subroutine for functions that do not return anything.

Let us exemplify a function without return values by making a table of the accuracy of the $L(x;n)$ approximation to $\ln(1+x)$ from the previous section:

```
def table(x):
    print '\nx=%g, ln(1+x)=%g' % (x, log(1+x))
    for n in [1, 2, 10, 100, 500]:
        value, next, error = L(x, n)
        print 'n=%-4d %-10g (next term: %8.2e '\
              'error: %8.2e)' % (n, value, next, error)
```

This function just performs a set of statements that we may want to run several times. Calling

```
table(10)
table(1000)
```

gives the output:

```
x=10, ln(1+x)=2.3979
n=1    0.909091    (next term: 4.13e-01  error: 1.49e+00)
n=2    1.32231     (next term: 2.50e-01  error: 1.08e+00)
n=10   2.17907     (next term: 3.19e-02  error: 2.19e-01)
n=100  2.39789     (next term: 6.53e-07  error: 6.59e-06)
```

⁵ The size of the terms decreases with increasing n , and the first neglected term is then bigger than all the remaining terms, but not necessarily bigger than their sum. The first neglected term is therefore only an indication of the size of the total error we make.

```

n=500  2.3979      (next term: 3.65e-24  error: 6.22e-15)

x=1000, ln(1+x)=6.90875
n=1    0.999001   (next term: 4.99e-01  error: 5.91e+00)
n=2    1.498      (next term: 3.32e-01  error: 5.41e+00)
n=10   2.919     (next term: 8.99e-02  error: 3.99e+00)
n=100  5.08989   (next term: 8.95e-03  error: 1.82e+00)
n=500  6.34928   (next term: 1.21e-03  error: 5.59e-01)

```

From this output we see that the sum converges much more slowly when x is large than when x is small. We also see that the error is an order of magnitude or more larger than the first neglected term in the sum. The functions `L` and `table` are found in the file `lnsum.py`.

When there is no explicit `return` statement in a function, Python actually inserts an invisible `return None` statement. `None` is a special object in Python that represents something we might think of as “empty data” or “nothing”. Other computer languages, such as C, C++, and Java, use the word “void” for a similar thing. Normally, one will call the `table` function without assigning the return value to any variable, but if we assign the return value to a variable, `result = table(500)`, `result` will refer to a `None` object.

The `None` value is often used for variables that should exist in a program, but where it is natural to think of the value as conceptually undefined. The standard way to test if an object `obj` is set to `None` or not reads

```

if obj is None:
    ...
if obj is not None:
    ...

```

One can also use `obj == None`. The `is` operator tests if two names refer to the same object, while `==` tests if the contents of two objects are the same:

```

>>> a = 1
>>> b = a
>>> a is b    # a and b refer to the same object
True
>>> c = 1.0
>>> a is c
False
>>> a == c   # a and c are mathematically equal
True

```

3.1.6 Keyword Arguments

Some function arguments can be given a default value so that we may leave out these arguments in the call, if desired. A typical function may look as

```
>>> def somefunc(arg1, arg2, kwarg1=True, kwarg2=0):
>>>     print arg1, arg2, kwarg1, kwarg2
```

The first two arguments, `arg1` and `arg2`, are *ordinary* or *positional* arguments, while the latter two are *keyword arguments* or *named arguments*. Each keyword argument has a name (in this example `kwarg1` and `kwarg2`) and an associated default value. The keyword arguments must always be listed after the positional arguments in the function definition.

When calling `somefunc`, we may leave out some or all of the keyword arguments. Keyword arguments that do not appear in the call get their values from the specified default values. We can demonstrate the effect through some calls:

```
>>> somefunc('Hello', [1,2])
Hello [1, 2] True 0
>>> somefunc('Hello', [1,2], kwarg1='Hi')
Hello [1, 2] Hi 0
>>> somefunc('Hello', [1,2], kwarg2='Hi')
Hello [1, 2] True Hi
>>> somefunc('Hello', [1,2], kwarg2='Hi', kwarg1=6)
Hello [1, 2] 6 Hi
```

The sequence of the keyword arguments does not matter in the call. We may also mix the positional and keyword arguments if we explicitly write `name=value` for all arguments in the call:

```
>>> somefunc(kwarg2='Hello', arg1='Hi', kwarg1=6, arg2=[1,2],)
Hi [1, 2] 6 Hello
```

Example: Function with Default Parameters. Consider a function of t which also contains some parameters, here A , a , and ω :

$$f(t; A, a, \omega) = Ae^{-at} \sin(\omega t). \quad (3.2)$$

We can implement f as a Python function where the independent variable t is an ordinary positional argument, and the parameters A , a , and ω are keyword arguments with suitable default values:

```
from math import pi, exp, sin
def f(t, A=1, a=1, omega=2*pi):
    return A*exp(-a*t)*sin(omega*t)
```

Calling `f` with just the `t` argument specified is possible:

```
v1 = f(0.2)
```

In this case we evaluate the expression $e^{-0.2} \sin(2\pi \cdot 0.2)$. Other possible calls include

```
v2 = f(0.2, omega=1)
v3 = f(1, A=5, omega=pi, a=pi**2)
v4 = f(A=5, a=2, t=0.01, omega=0.1)
v5 = f(0.2, 0.5, 1, 1)
```

You should write down the mathematical expressions that arise from these four calls. Also observe in the third line above that a positional argument, t in that case, can appear in between the keyword arguments if we write the positional argument on the keyword argument form `name=value`. In the last line we demonstrate that keyword arguments can be used as positional argument, i.e., the name part can be skipped, but then the sequence of the keyword arguments in the call must match the sequence in the function definition exactly.

Example: Computing a Sum with Default Tolerance. Consider the $L(x;n)$ sum and the Python implementation `L(x, n)` from Chapter 3.1.4. Instead of specifying the number of terms in the sum, n , it is better to specify a tolerance ϵ of the accuracy. We can use the first neglected term as an estimate of the accuracy. This means that we sum up terms as long as the absolute value of the next term is greater than ϵ . It is natural to provide a default value for ϵ :

```
def L2(x, epsilon=1.0E-6):
    x = float(x)
    i = 1
    term = (1.0/i)*(x/(1+x))**i
    s = term
    while abs(term) > epsilon: # abs(x) is |x|
        i += 1
        term = (1.0/i)*(x/(1+x))**i
        s += term
    return s, i
```

Here is an example involving this function to make a table of the approximation error as ϵ decreases:

```
from math import log
x = 10
for k in range(4, 14, 2):
    epsilon = 10**(-k)
    approx, n = L2(x, epsilon=epsilon)
    exact = log(1+x)
    exact_error = exact - approx
    print 'epsilon: %5.0e, exact error: %8.2e, n=%d' % \
        (epsilon, exact_error, n)
```

The output becomes

```
epsilon: 1e-04, exact error: 8.18e-04, n=55
epsilon: 1e-06, exact error: 9.02e-06, n=97
epsilon: 1e-08, exact error: 8.70e-08, n=142
epsilon: 1e-10, exact error: 9.20e-10, n=187
epsilon: 1e-12, exact error: 9.31e-12, n=233
```

We see that the `epsilon` estimate is almost 10 times smaller than the exact error, regardless of the size of `epsilon`. Since `epsilon` follows the exact error quite well over many orders of magnitude, we may view `epsilon` as a useful indication of the size of the error.

3.1.7 Doc Strings

There is a convention in Python to insert a documentation string right after the `def` line of the function definition. The documentation string, known as a *doc string*, should contain a short description of the purpose of the function and explain what the different arguments and return values are. Interactive sessions from a Python shell are also common to illustrate how the code is used. Doc strings are usually enclosed in triple double quotes `"""`, which allow the string to span several lines.

Here are two examples on short and long doc strings:

```
def C2F(C):
    """Convert Celsius degrees (C) to Fahrenheit."""
    return (9.0/5)*C + 32

def line(x0, y0, x1, y1):
    """
    Compute the coefficients a and b in the mathematical
    expression for a straight line  $y = a*x + b$  that goes
    through two points (x0, y0) and (x1, y1).

    x0, y0: a point on the line (floats).
    x1, y1: another point on the line (floats).
    return: coefficients a, b (floats) for the line (y=a*x+b).
    """
    a = (y1 - y0)/float(x1 - x0)
    b = y0 - a*x0
    return a, b
```

Note that the doc string must appear before any statement in the function body.

There are several Python tools that can automatically extract doc strings from the source code and produce various types of documentation, see [5, App. B.2]. The doc string can be accessed in a code as `funcname.__doc__`, where `funcname` is the name of the function, e.g.,

```
print line.__doc__
```

which prints out the documentation of the `line` function above:

```
Compute the coefficients a and b in the mathematical
expression for a straight line  $y = a*x + b$  that goes
through two points (x0, y0) and (x1, y1).

x0, y0: a point on the line (float objects).
x1, y1: another point on the line (float objects).
return: coefficients a, b for the line (y=a*x+b).
```

Doc strings often contain interactive sessions, copied from a Python shell, to illustrate how the function is used. We can add such a session to the doc string in the `line` function:

```
def line(x0, y0, x1, y1):
    """
    Compute the coefficients a and b in the mathematical
    expression for a straight line  $y = a*x + b$  that goes
    through two points (x0,y0) and (x1,y1).
```

```
x0, y0: a point on the line (float).
x1, y1: another point on the line (float).
return: coefficients a, b (floats) for the line (y=a*x+b).
```

```
Example:
>>> a, b = line(1, -1, 4, 3)
>>> a
1.3333333333333333
>>> b
-2.3333333333333333
"""
a = (y1 - y0)/float(x1 - x0)
b = y0 - a*x0
return a, b
```

A particularly nice feature is that all such interactive sessions in doc strings can be automatically run, and new results are compared to the results found in the doc strings. This makes it possible to use interactive sessions in doc strings both for exemplifying how the code is used and for testing that the code works.

3.1.8 Function Input and Output

It is a convention in Python that function arguments represent the input data to the function, while the returned objects represent the output data. We can sketch a general Python function as

```
def somefunc(i1, i2, i3, io4, io5, i6=value1, io7=value2):
    # modify io4, io5, io6; compute o1, o2, o3
    return o1, o2, o3, io4, io5, io7
```

Here `i1`, `i2`, `i3` are positional arguments representing input data; `io4` and `io5` are positional arguments representing input *and* output data; `i6` and `io7` are keyword arguments representing input and input/output data, respectively; and `o1`, `o2`, and `o3` are computed objects in the function, representing output data together with `io4`, `io5`, and `io7`. All examples later in the book will make use of this convention.

3.1.9 Functions as Arguments to Functions

Programs doing calculus frequently need to have functions as arguments in other functions. For example, for a mathematical function $f(x)$ we can have Python functions for

1. numerical root finding: solve $f(x) = 0$ approximately (Chapters 4.6.2 and A.1.10)
2. numerical differentiation: compute $f'(x)$ approximately (Appendix B and Chapters 7.3.2 and 9.2)
3. numerical integration: compute $\int_a^b f(x)dx$ approximately (Appendix B and Chapters 7.3.3 and 9.3)

4. numerical solution of differential equations: $\frac{dx}{dt} = f(x)$ (Appendices C and E)

In such Python functions we need to have the $f(x)$ function as an argument `f`. This is straightforward in Python and hardly needs any explanation, but in most other languages special constructions must be used for transferring a function to another function as argument.

As an example, consider a function for computing the second-order derivative of a function $f(x)$ numerically:

$$f''(x) \approx \frac{f(x-h) - 2f(x) + f(x+h)}{h^2}, \quad (3.3)$$

where h is a small number. The approximation (3.3) becomes exact in the limit $h \rightarrow 0$. A Python function for computing (3.3) can be implemented as follows:

```
def diff2(f, x, h=1E-6):
    r = (f(x-h) - 2*f(x) + f(x+h))/float(h*h)
    return r
```

The `f` argument is like any other argument, i.e., a name for an object, here a function object that we can call as we normally call function objects. An application of `diff2` can read

```
def g(t):
    return t**(-6)

t = 1.2
d2g = diff2(g, t)
print "g' (%f)=%f" % (t, d2g)
```

The Behavior of the Numerical Derivative as $h \rightarrow 0$. From mathematics we know that the approximation formula (3.3) becomes more accurate as h decreases. Let us try to demonstrate this expected feature by making a table of the second-order derivative of $g(t) = t^{-6}$ at $t = 1$ as $h \rightarrow 0$:

```
for k in range(1,15):
    h = 10**(-k)
    d2g = diff2(g, 1, h)
    print 'h=%.0e: %.5f' % (h, d2g)
```

The output becomes

```
h=1e-01: 44.61504
h=1e-02: 42.02521
h=1e-03: 42.00025
h=1e-04: 42.00000
h=1e-05: 41.99999
h=1e-06: 42.00074
h=1e-07: 41.94423
h=1e-08: 47.73959
h=1e-09: -666.13381
h=1e-10: 0.00000
h=1e-11: 0.00000
h=1e-12: -666133814.77509
```

```
h=1e-13: 66613381477.50939
h=1e-14: 0.00000
```

With $g(t) = t^{-6}$, the exact answer is $g''(1) = 42$, but for $h < 10^{-8}$ the computations give totally wrong answers! The problem is that for small h on a computer, round-off errors in the formula (3.3) blow up and destroy the accuracy. The mathematical result that (3.3) becomes an increasingly better approximation as h gets smaller and smaller does not hold on a computer! Or more precisely, the result holds until h in the present case reaches 10^{-4} .

The reason for the inaccuracy is that the numerator in (3.3) for $g(t) = t^{-6}$ and $t = 1$ contains subtraction of quantities that are almost equal. The result is a very small and inaccurate number. The inaccuracy is magnified by h^{-2} , a number that becomes very large for small h . Switching from the standard floating-point numbers (`float`) to numbers with arbitrary high precision resolves the problem. Python has a module `decimal` that can be used for this purpose. The file `highprecision.py` solves the current problem using arithmetics based on the `decimal` module. With 25 digits in `x` and `h` inside the `diff2` function, we get accurate results for $h \leq 10^{-13}$. However, for most practical applications of (3.3), a moderately small h , say $10^{-3} \leq h \leq 10^{-4}$, gives sufficient accuracy and then round-off errors from `float` calculations do not pose problems. Real-world science or engineering applications usually have many parameters with uncertainty, making the end result also uncertain, and formulas like (3.3) can then be computed with moderate accuracy without affecting the overall computational error.

3.1.10 The Main Program

In programs containing functions we often refer to a part of the program that is called the *main program*. This is the collection of all the statements outside the functions, plus the definition of all functions. Let us look at a complete program:

```
from math import *                # in main
def f(x):                          # in main
    e = exp(-0.1*x)
    s = sin(6*pi*x)
    return e*s
x = 2                               # in main
y = f(x)                            # in main
print 'f(%g)=%g' % (x, y)         # in main
```

The main program here consists of the lines with a comment `in main`. The execution always starts with the first line in the main program. When a function is encountered, its statements are just used to define the function – nothing gets computed inside the function before we ex-

explicitly call the function, either from the main program or from another function. All variables initialized in the main program become global variables (see Chapter 3.1.2).

The program flow in the program above goes as follows:

1. Import functions from the `math` module,
2. define a function `f(x)`,
3. define `x`,
4. call `f` and execute the function body,
5. define `y` as the value returned from `f`,
6. print the string.

In point 4, we jump to the `f` function and execute the statement inside that function for the first time. Then we jump back to the main program and assign the `float` object returned from `f` to the `y` variable.

Readers who are uncertain about the program flow and the jumps between the main program and functions should learn to use a debugger, see Appendix F.1.

3.1.11 Lambda Functions

There is a quick one-line construction of functions that is sometimes convenient:

```
f = lambda x: x**2 + 4
```

This so-called *lambda function* is equivalent to writing

```
def f(x):  
    return x**2 + 4
```

In general,

```
def g(arg1, arg2, arg3, ...):  
    return expression
```

can be written as

```
g = lambda arg1, arg2, arg3, ...: expression
```

Lambda functions are usually used to quickly define a function as argument to another function. Consider, as an example, the `diff2` function from Chapter 3.1.9. In the example from that chapter we want to differentiate $g(t) = t^{-6}$ twice and first make a Python function `g(t)` and then send this `g` to `diff2` as argument. We can skip the step with defining the `g(t)` function and instead insert a lambda function as the `f` argument in the call to `diff2`:

```
d2 = diff2(lambda t: t**(-6), 1, h=1E-4)
```

Because lambda functions can be defined “on the fly” and thereby save typing of a separate function with `def` and an intended block, lambda functions are popular among many programmers.

Lambda functions may also take keyword arguments. For example,

```
d2 = diff2(lambda t, A=1, a=0.5: -a*2*t*A*exp(-a*t**2), 1.2)
```

3.2 Branching

The flow of computer programs often needs to branch. That is, if a condition is met, we do one thing, and if not, we do another thing. A simple example is a function defined as

$$f(x) = \begin{cases} \sin x, & 0 \leq x \leq \pi \\ 0, & \text{otherwise} \end{cases} \quad (3.4)$$

In a Python implementation of this function we need to test on the value of x , which can be done as displayed below:

```
def f(x):
    if 0 <= x <= pi:
        value = sin(x)
    else:
        value = 0
    return value
```

3.2.1 If-Else Blocks

The general structure of an if-else test is

```
if condition:
    <block of statements, executed if condition is True>
else:
    <block of statements, executed if condition is False>
```

When `condition` evaluates to true, the program flow branches into the first block of statements. If `condition` is `False`, the program flow jumps to the second block of statements, after the `else:` line. As with `while` and `for` loops, the block of statements are indented. Here is another example:

```
if C < -273.15:
    print '%g degrees Celsius is non-physical!' % C
    print 'The Fahrenheit temperature will not be computed.'
else:
    F = 9.0/5*C + 32
    print F
print 'end of program'
```

The two `print` statements in the `if` block are executed if and only if `C < -273.15` evaluates to `True`. Otherwise, we jump over the first two `print` statements and carry out the computation and printing of `F`. The printout of `end of program` will be performed regardless of the outcome of the `if` test since this statement is not indented and hence neither a part of the `if` block nor the `else` block.

The `else` part of an `if` test can be skipped, if desired:

```
if condition:
    <block of statements>
<next statement>
```

For example,

```
if C < -273.15:
    print '%s degrees Celsius is non-physical!' % C
F = 9.0/5*C + 32
```

In this case the computation of `F` will always be carried out, since the statement is not indented and hence not a part of the `if` block.

With the keyword `elif`, short for *else if*, we can have several mutually exclusive `if` tests, which allows for multiple branching of the program flow:

```
if condition1:
    <block of statements>
elif condition2:
    <block of statements>
elif condition3:
    <block of statements>
else:
    <block of statements>
<next statement>
```

The last `else` part can be skipped if it is not needed. To illustrate multiple branching we will implement a “hat” function, which is widely used in advanced computer simulations in science and industry. One example of a “hat” function is

$$N(x) = \begin{cases} 0, & x < 0 \\ x, & 0 \leq x < 1 \\ 2 - x, & 1 \leq x < 2 \\ 0, & x \geq 2 \end{cases} \quad (3.5)$$

The solid line in Figure 5.9 on page 218 illustrates the shape of this function. The Python implementation associated with (3.5) needs multiple `if` branches:

```
def N(x):
    if x < 0:
        return 0.0
    elif 0 <= x < 1:
        return x
    elif 1 <= x < 2:
```

```

    return 2 - x
elif x >= 2:
    return 0.0

```

This code corresponds directly to the mathematical specification, which is a sound strategy that usually leads to fewer errors in programs. We could mention that there is another way of constructing this `if` test that results in shorter code:

```

def N(x):
    if 0 <= x < 1:
        return x
    elif 1 <= x < 2:
        return 2 - x
    else:
        return 0

```

As a part of learning to program, understanding this latter sample code is important, but we recommend the former solution because of its direct similarity with the mathematical definition of the function.

A popular programming rule is to avoid multiple `return` statements in a function – there should only be one `return` at the end. We can do that in the `N` function by introducing a local variable, assigning values to this variable in the blocks and returning the variable at the end. However, we do not think an extra variable and an extra line make a great improvement in such a short function. Nevertheless, in long and complicated functions the rule can be helpful.

3.2.2 Inline If Tests

A variable is often assigned a value that depends on a boolean expression. This can be coded using a common `if-else` test:

```

if condition:
    a = value1
else:
    a = value2

```

Because this construction is often needed, Python provides a one-line syntax for the four lines above:

```

a = (value1 if condition else value2)

```

The parentheses are not required, but recommended style. One example is

```

def f(x):
    return (sin(x) if 0 <= x <= 2*pi else 0)

```

Since the inline `if` test is an expression with a value, it can be used in lambda functions:

```
f = lambda x: sin(x) if 0 <= x <= 2*pi else 0
```

The traditional `if-else` construction with indented blocks cannot be used inside `lambda` functions because it is not just an expression (`lambda` functions cannot have statements inside them, only a single expression).

3.3 Mixing Loops, Branching, and Functions in Bioinformatics Examples

Life is definitely digital. The genetic code of all living organisms are represented by a long sequence of simple molecules called nucleotides, or bases, which makes up the Deoxyribonucleic acid, better known as DNA. There are only four such nucleotides, and the entire genetic code of a human can be seen as a simple, though 3 billion long, string of the letters A, C, G, and T. Analyzing DNA data to gain increased biological understanding is much about searching in (long) strings for certain string patterns involving the letters A, C, G, and T. This is an integral part of *bioinformatics*, a scientific discipline addressing the use of computers to search for, explore, and use information about genes, nucleic acids, and proteins.

The leading Python software for bioinformatics applications is BioPython (found at <http://biopython.org>). The examples in this book (below and Chapters 6.6, 8.3.4, and 9.5) are simple illustrations of the type of problem settings and corresponding Python implementations that are encountered in bioinformatics. For real-world problem solving one should rather utilize BioPython, but the sections below acts as an introduction to what is inside packages like BioPython.

We start with some very simple examples on DNA analysis which bring together basic building blocks in programming: loops, `if` tests, and functions.

3.3.1 Counting Letters in DNA Strings

Given some string `dna` containing the letters A, C, G, or T, representing the bases that make up DNA, we ask the question: how many times does a certain base occur in the DNA string? For example, if `dna` is `ATGGCATT` and we ask how many times the base A occur in this string, the answer is 3.

A general Python implementation answering this problem can be done in many ways. Several possible solutions are presented below.

List Iteration. The most straightforward solution is to loop over the letters in the string, test if the current letter equals the desired one,

and if so, increase a counter. Looping over the letters is obvious if the letters are stored in a list. This is easily done by converting a string to a list:

```
>>> list('ATGC')
['A', 'T', 'G', 'C']
```

Our first solution becomes

```
def count_v1(dna, base):
    dna = list(dna) # convert string to list of letters
    i = 0          # counter
    for c in dna:
        if c == base:
            i += 1
    return i
```

String Iteration. Python allows us to iterate directly over a string without converting it to a list:

```
>>> for c in 'ATGC':
...     print c
A
T
G
C
```

In fact, all built-in objects in Python that contain a set of elements in a particular sequence allow a `for` loop construction of the type `for element in object`.

A slight improvement of our solution is therefore to iterate directly over the string:

```
def count_v2(dna, base):
    i = 0 # counter
    for c in dna:
        if c == base:
            i += 1
    return i

dna = 'ATGCGGACCTAT'
base = 'C'
n = count_v2(dna, base)

# printf-style formatting
print '%s appears %d times in %s' % (base, n, dna)

# or (new) format string syntax
print '{base} appears {n} times in {dna}'.format(
    base=base, n=n, dna=dna)
```

We have here illustrated two alternative ways of writing out text where the value of variables are to be inserted in “slots” in the string.

Program Flow. It is fundamental for correct programming to understand how to simulate a program by hand, statement by statement.

Three tools are effective for helping you reach the required understanding of performing a simulation by hand: (i) printing variables, (ii) using a debugger, and (iii) using an [online program flow tool](#).

Inserting print statements and examining the variables is the simplest approach to investigating what is going on:

```
def count_v2_demo(dna, base):
    print 'dna:', dna
    print 'base:', base
    i = 0 # counter
    for c in dna:
        print 'c:', c
        if c == base:
            print 'True if test'
            i += 1
    return i

n = count_v2_demo('ATGCGGACCTAT', 'C')
```

An efficient way to explore this program is to run it in a debugger where we can step through each statement and see what is printed out. Start `ipython` in a terminal window and run the program `count_v2_demo.py` with a debugger: `run -d count_v2_demo.py`. Use `s` (for step) to step through each statement, or `n` (for next) for proceeding to the next statement without stepping through a function that is called.

```
ipdb> s
> /some/disk/user/bioinf/src/count_v2_demo.py(2)count_v2_demo()
1      1 def count_v1_demo(dna, base):
----> 2      print 'dna:', dna
      3      print 'base:', base

ipdb> s
dna: ATGCGGACCTAT
> /some/disk/user/bioinf/src/count_v2_demo.py(3)count_v2_demo()
      2      print 'dna:', dna
----> 3      print 'base:', base
      4      i = 0 # counter
```

Observe the output of the print statements. One can also print a variable explicitly inside the debugger:

```
ipdb> print base
C
```

Misunderstanding of the program flow is one of the most frequent sources of programming errors, so whenever in doubt about any program flow, enter a debugger to establish confidence!

The [Python Online Tutor](#) at

<http://people.csail.mit.edu/pgbovine/python/tutor.html>

is, at least for small programs, a splendid alternative to debuggers. Go to the web page, erase the sample code and paste in your own code. Press *Visual execution*, then *Forward* to execute statements one by

one. The status of variables are explained to the right, and the text field below the program shows the output from print statements. An example is shown in Figure 3.1.

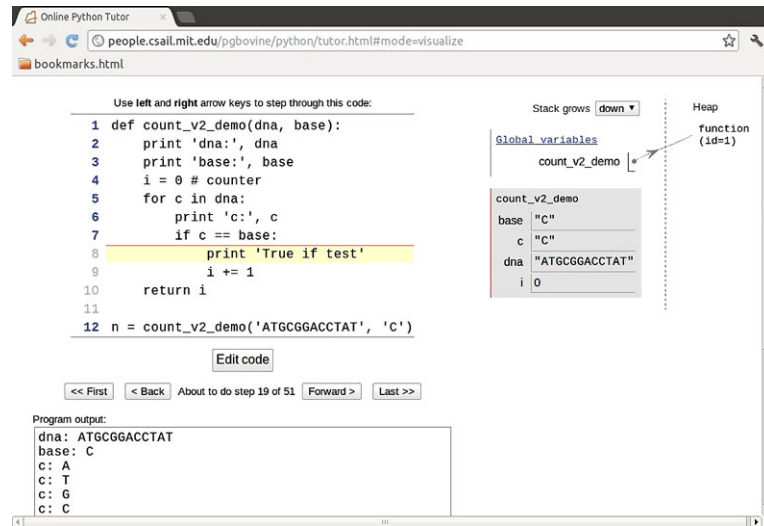

Fig. 3.1 Visual execution of a program using the Python Online Tutor.

Index Iteration. Although it is natural in Python to iterate over the letters in a string (or more generally over elements in a sequence), programmers with experience from other languages (Fortran, C and Java are examples) are used to `for` loops with an integer counter running over all indices in a string or array:

```
def count_v3(dna, base):
    i = 0 # counter
    for j in range(len(dna)):
        if dna[j] == base:
            i += 1
    return i
```

Python indices always start at 0 so the legal indices for our string become 0, 1, ..., $\text{len}(\text{dna})-1$, where $\text{len}(\text{dna})$ is the number of letters in the string `dna`. The `range(x)` function returns a list of integers 0, 1, ..., $x-1$, implying that `range(len(dna))` generates all the legal indices for `dna`.

While Loops. The while loop equivalent to the last function reads

```
def count_v4(dna, base):
    i = 0 # counter
    j = 0 # string index
    while j < len(dna):
        if dna[j] == base:
            i += 1
        j += 1
    return i
```

Correct indentation is here crucial: a typical error is to fail indenting the `j += 1` line correctly.

Summing a Boolean List. The idea now is to create a list `m` where `m[i]` is `True` if `dna[i]` equals the letter we search for (`base`). The number of `True` values in `m` is then the number of `base` letters in `dna`. We can use the `sum` function to find this number because doing arithmetics with boolean lists automatically interprets `True` as 1 and `False` as 0. That is, `sum(m)` returns the number of `True` elements in `m`. A possible function doing this is

```
def count_v5(dna, base):
    m = [] # matches for base in dna: m[i]=True if dna[i]==base
    for c in dna:
        if c == base:
            m.append(True)
        else:
            m.append(False)
    return sum(m)
```

Inline If Test. Shorter, more compact code is often a goal if the compactness enhances readability. The four-line `if` test in the previous function can be condensed to one line using the inline `if` construction: `if condition value1 else value2`.

```
def count_v6(dna, base):
    m = [] # matches for base in dna: m[i]=True if dna[i]==base
    for c in dna:
        m.append(True if c == base else False)
    return sum(m)
```

Using Boolean Values Directly. The inline `if` test is in fact redundant in the previous function because the value of the condition `c == base` can be used directly: it has the value `True` or `False`. This saves some typing and adds clarity, at least to Python programmers with some experience:

```
def count_v7(dna, base):
    m = [] # matches for base in dna: m[i]=True if dna[i]==base
    for c in dna:
        m.append(c == base)
    return sum(m)
```

List Comprehensions. Building a list with the aid of a `for` loop can often be condensed to a single line by using list comprehensions: `[expr for e in sequence]`, where `expr` is some expression normally involving the iteration variable `e`. In our last example, we can introduce a list comprehension

```
def count_v8(dna, base):
    m = [c == base for c in dna]
    return sum(m)
```

Here it is tempting to get rid of the `m` variable and reduce the function body to a single line:

```
def count_v9(dna, base):
    return sum([c == base for c in dna])
```

Using a Sum Iterator. The DNA string is usually huge – 3 billion letters for the human species. Making a boolean array with `True` and `False` values therefore increases the memory usage by a factor of two in our sample functions `count_v5` to `count_v9`. Summing without actually storing an extra list is desirable. Fortunately, `sum([x for x in s])` can be replaced by `sum(x for x in s)`, where the latter sums the elements in `s` as `x` visits the elements of `s` one by one. Removing the brackets therefore avoids first making a list before applying `sum` on that list. This is a minor modification of the `count_v9` function:

```
def count_v10(dna, base):
    return sum(c == base for c in dna)
```

Below we shall measure the impact of the various program constructs on the CPU time.

Extracting Indices. Instead of making a boolean list with elements expressing whether a letter matches the given `base` or not, we may collect all the indices of the matches. This can be done by adding an `if` test to the list comprehension:

```
def count_v11(dna, base):
    return len([i for i in range(len(dna)) if dna[i] == base])
```

A debugger or the Python Online Tutorial do not help so much when trying to understand this compact code. A better approach is to examine the list comprehension in an interactive Python shell:

```
>>> dna = 'AATGCTTA'
>>> base = 'A'
>>> indices = [i for i in range(len(dna)) if dna[i] == base]
>>> indices
[0, 1, 7]
>>> print dna[0], dna[1], dna[7] # check
A A A
```

The element `i` in the list comprehension is only made for those `i` where `dna[i] == base`.

Using Python's Library. Very often when you set out to do a task in Python, there is already functionality for the task in the object itself, in

the Python libraries, or in third-party libraries found on the Internet. Counting how many times a letter (or substring) `base` appears in a string `dna` is obviously a very common task so Python supports it by the syntax `dna.count(base)`:

```
def count_v12(dna, base):
    return dna.count(base)
```

3.3.2 Efficiency Assessment

Now we have 11 different versions of how to count the occurrences of a letter in a string. Which one of these implementations is the fastest? To answer the question we need some test data, which should be a huge string `dna`.

Generating Random DNA Strings. The simplest way of generating a long string is to repeat a character a large number of times:

```
N = 1000000
dna = 'A'*N
```

The resulting string is just `'AAA...A'`, of length `N`, which is fine for testing the efficiency of Python functions. Nevertheless, it is more exciting to work with a DNA string with letters from the whole alphabet A, C, G, and T. To make a DNA string with a random composition of the letters we can first make a list of random letters and then join all those letters to a string:

```
import random
alphabet = list('ATGC')
dna = [random.choice(alphabet) for i in range(N)]
dna = ''.join(dna) # join the list elements to a string
```

The `random.choice(x)` function selects an element in the list `x` at random.

Note that `N` is very often a large number. In Python version 2.x, `range(N)` generates a list of `N` integers. We can avoid the list by using `xrange` which generates an integer at a time and not the whole list. In Python version 3.x, the `range` function is actually the `xrange` function in version 2.x. Using `xrange`, combining the statements, and wrapping the construction of a random DNA string in a function, gives

```
import random

def generate_string(N, alphabet='ACGT'):
    return ''.join([random.choice(alphabet) for i in xrange(N)])

dna = generate_string(600000)
#dna = generate_string(6000000)
```

The call `generate_string(10)` may generate something like `AATGGCAGAA`.

Measuring CPU Time. Our next goal is to see how much time the various `count_v*` functions spend on counting letters in a huge string, which is to be generated as shown above. Measuring the time spent in a program can be done by the `time` module:

```
import time
...
t0 = time.clock()
# do stuff
t1 = time.clock()
cpu_time = t1 - t0
```

The `time.clock()` function returns the CPU time spent in the program since its start. If the interest is in the total time, also including reading and writing files, `time.time()` is the appropriate function to call.

Running through all our functions made so far and recording timings can be done by

```
import time
functions = [count_v1, count_v2, count_v3, count_v4,
            count_v5, count_v6, count_v7, count_v8,
            count_v9, count_v10, count_v11, count_v12]
timings = [] # timings[i] holds CPU time for functions[i]

for function in functions:
    t0 = time.clock()
    function(dna, 'A')
    t1 = time.clock()
    cpu_time = t1 - t0
    timings.append(cpu_time)
```

In Python, functions are ordinary objects so making a list of functions is no more special than making a list of strings or numbers.

We can now iterate over `timings` and `functions` simultaneously via `zip` to make a nice printout of the results:

```
for cpu_time, function in zip(timings, functions):
    print '{f:<9s}: {cpu:.2f} s'.format(
        f=function.func_name, cpu=cpu_time)
```

Timings on a MacBook Air 11 running Ubuntu show that the functions using `list.append` require almost the double of the time of the functions that work with list comprehensions. Even faster is the simple iteration over the string. However, the built-in count functionality of strings (`dna.count(base)`) runs over 30 times faster than the best of our handwritten Python functions! The reason is that the `for` loop needed to count in `dna.count(base)` is actually implemented in C and runs very much faster than loops in Python.

A clear lesson learned is: google around before you start out to implement what seems to be a quite common task. Others have probably already done it for you, and most likely is their solution much better than what you can (easily) come up with.

All the functions presented above, including the timings, can be found in the file `count.py`.

3.4 Summary

3.4.1 Chapter Topics

User-Defined Functions. Functions are useful (i) when a set of commands are to be executed several times, or (ii) to partition the program into smaller pieces to gain better overview. Function arguments are local variables inside the function whose values are set when calling the function. Remember that when you write the function, the values of the arguments are not known. Here is an example of a function for polynomials of 2nd degree:

```
# function definition:
def quadratic_polynomial(x, a, b, c)
    value = a*x*x + b*x + c
    derivative = 2*a*x + b
    return value, derivative

# function call:
x = 1
p, dp = quadratic_polynomial(x, 2, 0.5, 1)
p, dp = quadratic_polynomial(x=x, a=-4, b=0.5, c=0)
```

The sequence of the arguments is important, unless all arguments are given as name=value.

Functions may have no arguments and/or no return value(s):

```
def print_date():
    """Print the current date in the format 'Jan 07, 2007'."""
    import time
    print time.strftime("%b %d, %Y")

# call:
print_date()
```

A common error is to forget the parentheses: `print_date` is the function object itself, while `print_date()` is a call to the function.

Keyword Arguments. Function arguments with default values are called keyword arguments, and they help to document the meaning of arguments in function calls. They also make it possible to specify just a subset of the arguments in function calls.

```
from math import exp, sin, pi

def f(x, A=1, a=1, w=pi):
    return A*exp(-a*x)*sin(w*x)

f1 = f(0)
x2 = 0.1
f2 = f(x2, w=2*pi)
f3 = f(x2, w=4*pi, A=10, a=0.1)
f4 = f(w=4*pi, A=10, a=0.1, x=x2)
```

The sequence of the keyword arguments can be arbitrary, and the keyword arguments that are not listed in the call get their default values

according to the function definition. The “non-keyword arguments” are called positional arguments, which is `x` in this example. Positional arguments must be listed before the keyword arguments. However, also a positional argument can appear as `name=value` in the call (see the last line above), and this syntax allows any positional argument to be listed anywhere in the call.

If Tests. The `if-elif-else` tests are used to “branch” the flow of statements. That is, different sets of statements are executed depending on whether a set of conditions is true or not.

```
def f(x):
    if x < 0:
        value = -1
    elif x >= 0 and x <= 1:
        value = x
    else:
        value = 1
    return value
```

Inline If Tests. Assigning a variable one value if a condition is true and another value otherwise, is compactly done with an inline if test:

```
sign = -1 if a < 0 else 1
```

Terminology. The important computer science terms in this chapter are

- function,
- method,
- return statement,
- positional arguments,
- keyword arguments,
- local and global variables,
- doc strings,
- if tests with `if`, `elif`, and `else` (branching),
- the `None` object.

3.4.2 Example: Numerical Integration

Problem. An integral

$$\int_a^b f(x)dx$$

can be approximated by the so-called Simpson’s rule:

$$\int_a^b f(x)dx \approx \frac{b-a}{3n} \left(f(a) + f(b) + 4 \sum_{i=1}^{n/2} f(a + (2i-1)h) + 2 \sum_{i=1}^{n/2-1} f(a + 2ih) \right). \quad (3.6)$$

Here, $h = (b - a)/n$ and n must be an even integer. The problem is to make a function `Simpson(f, a, b, n=500)` that returns the right-hand side formula of (3.6). Apply the formula to $\frac{3}{2} \int_0^\pi \sin^3 x dx$, which has exact value 2, for $n = 2, 6, 12, 100, 500$. (A better verification of the implementation, is to use the fact (3.6) is *exact* for all polynomials $f(x)$ of degree ≤ 2 .)

Solution. The evaluation of the formula (3.6) in a program is straightforward if we know how to implement summation (\sum) and how to call f . A Python recipe for calculating sums is given in Chapter 3.1.4. Basically, $\sum_{i=M}^N q(i)$, for some expression $q(i)$ involving i , is coded with the aid of a `for` loop over i and an accumulation variable `s` for building up the sum, one term at a time:

```
s = 0
for i in range(M, N):
    s += q(i)
```

The Simpson function can then be coded as

```
def Simpson(f, a, b, n=500):
    h = (b - a)/float(n)
    sum1 = 0
    for i in range(1, n/2 + 1):
        sum1 += f(a + (2*i-1)*h)

    sum2 = 0
    for i in range(1, n/2):
        sum2 += f(a + 2*i*h)

    integral = (b-a)/(3*n)*(f(a) + f(b) + 4*sum1 + 2*sum2)
    return integral
```

Note that `Simpson` can integrate any Python function `f` of one variable. Specifically, we can implement

$$h(x) = \frac{3}{2} \sin^3 x dx$$

in a Python function

```
def h(x):
    return (3./2)*sin(x)**3
```

and call `Simpson` to compute $\int_0^\pi h(x) dx$ for various choices of n , as requested:

```
from math import sin, pi

def application():
    print 'Integral of 1.5*sin^3 from 0 to pi:'
    for n in 2, 6, 12, 100, 500:
        approx = Simpson(h, 0, pi, n)
        print 'n=%3d, approx=%18.15f, error=%9.2E' % \
            (n, approx, 2-approx)
```

We put these statements inside a function, here called `application`, mainly to group them, and not because `application` will be called several times or with different arguments. Running the call `application()` leads to the output

```
Integral of 1.5*sin^3 from 0 to pi:
n= 2, approx= 3.141592653589793, error=-1.14E+00
n= 6, approx= 1.989171700583579, error= 1.08E-02
n= 12, approx= 1.999489233010781, error= 5.11E-04
n=100, approx= 1.99999902476350, error= 9.75E-08
n=500, approx= 1.99999999844138, error= 1.56E-10
```

We clearly see that the approximation improves as n increases. However, every computation will give an answer that deviates from the exact value 2. We cannot from this test alone know if the errors above are those implied by the approximation only, or if there are additional programming mistakes. A better way of verifying the implementation is therefore to look for test cases where the numerical approximation formula is exact. Since it is stated that the formula is exact for polynomials up to second degree, we just test it on such an “arbitrary” parabola, say

$$\int_{3/2}^2 (3x^2 - 7x + 2.5) dx.$$

This integral equals $G(2) - G(3/2)$, where $G(x) = x^3 - 3.5x^2 + 2.5x$. A possible implementation becomes

```
def g(x):
    return 3*x**2 - 7*x + 2.5

def G(x):
    return x**3 - 3.5*x**2 + 2.5*x

def verify():
    a = 1.5
    b = 2.0
    n = 8
    exact = G(b) - G(a)
    approx = Simpson(g, a, b, n)
    if abs(exact - approx) > 1E-14:
        print "Error: Simpson's rule should integrate g exactly"
```

Note the last if test: we avoid testing `exact == approx` because there may be round-off errors in these float objects so that `==` fails. Testing that the two variables are very close (distance less than 10^{-14}) is better, cf. Exercises 2.23 and 2.24.

The `g` and `G` functions are only of interest inside the `verify` function. Many think the code becomes easier to read and understand if `g` and `G` are moved inside `verify`, which is indeed possible in Python:

```
def verify():
    def g(x):
        # test function that Simpson's rule will integrate exactly
        return 3*x**2 - 7*x + 2.5

    def G(x):
        # integral of g(x)
```



```

        return x**3 - 3.5*x**2 + 2.5*x

a = 1.5
b = 2.0
n = 8
exact = G(b) - G(a)
approx = Simpson(g, a, b, n)
if abs(exact - approx) > 1E-14:
    print "Error: Simpson's rule should integrate g exactly"

```

We can make the `verify` function more compact by utilizing lambda functions for `g` and `G` (see Chapter 3.1.11):

```

def verify():
    """Check that 2nd-degree polynomials are integrated exactly."""
    a = 1.5
    b = 2.0
    n = 8
    g = lambda x: 3*x**2 - 7*x + 2.5      # test integrand
    G = lambda x: x**3 - 3.5*x**2 + 2.5*x # integral of g
    exact = G(b) - G(a)
    approx = Simpson(g, a, b, n)
    if abs(exact - approx) > 1E-14:
        print "Error: Simpson's rule should integrate g exactly"

```

Another improvement is to increase robustness of the function, i.e., that the input data, i.e., the arguments, are acceptable. Here we may test if $b > a$ and if n is an even integer. For the latter test, we make use of the `mod` function: `mod(n, d)` gives the remainder when n is divided by d (both n and d are integers). Mathematically, if p is the largest integer such that $pd \leq n$, then `mod(n, d)` is $n - pd$. For example, `mod(3, 2)` is 1, `mod(3, 1)` is 0, `mod(3, 3)` is 0, and `mod(18, 8)` is 2. The point is that n divided by d is an integer when `mod(n, d)` is zero. In Python, the percentage sign is used for the mod function:

```

>>> 18 % 8
2

```

To test if n is an odd integer, we see if it can be divided by 2 and yield an integer without any remainder (`n % 2 == 0`).

The improved Simpson function with validity tests on the provided arguments, as well as a doc string (Chapter 3.1.7), can look like this:

```

def Simpson(f, a, b, n=500):
    """
    Return the approximation of the integral of f
    from a to b using Simpson's rule with n intervals.
    """
    if a > b:
        print 'Error: a=%g > b=%g' % (a, b)
        return None

    # check that n is even:
    if n % 2 != 0:
        print 'Error: n=%d is not an even integer!' % n
        n = n+1 # make n even

    h = (b - a)/float(n)

```

```

sum1 = 0
for i in range(1, n/2 + 1):
    sum1 += f(a + (2*i-1)*h)

sum2 = 0
for i in range(1, n/2):
    sum2 += f(a + 2*i*h)

integral = (b-a)/(3*n)*(f(a) + f(b) + 4*sum1 + 2*sum2)
return integral

```

The complete code is found in the file `Simpson.py`.

A very good exercise is to simulate the program flow by hand, starting with the call to the `application` function. A debugger might be a convenient tool for controlling that your thinking is correct, see Appendix F.1.

3.5 Exercises

Exercise 3.1. Write a *Fahrenheit–Celsius conversion function*.

The formula for converting Fahrenheit degrees to Celsius reads

$$C = \frac{5}{9}(F - 32). \quad (3.7)$$

Write a function `C(F)` that implements this formula. To verify the implementation of `C(F)`, you can convert a Celsius temperature to Fahrenheit and then back to Celsius again using the `F(C)` function from Chapter 3.1.1 and the `C(F)` function implementing (3.7). That is, you can check that the boolean expression `c == C(F(c))` is `True` for any temperature `c` (you should, however, be careful with comparing real numbers with `==`, see Exercise 2.24). Name of program file: `f2c.py`. \diamond

Exercise 3.2. Write the program in Exer. 2.12 as a function.

Define a Python function `sum_1_div_k(M)` that returns the sum s as defined in Exercise 2.12. Print out the result of calling `s(3)` and check that the answer is correct. Name of program: `sum_func.py`. \diamond

Exercise 3.3. Write a function for solving $ax^2 + bx + c = 0$.

Given a quadratic equation $ax^2 + bx + c = 0$, write a function `roots(a, b, c)` that returns the two roots of the equation. The returned roots should be `float` objects when the roots are real, otherwise the roots should be `complex` objects. Construct two test cases with known solutions, one with real roots and the other with complex roots, to check that the function returns correct values and correct type of objects. Hint: Use techniques from Chapter 1.6.3. Name of program: `roots_quadratic.py`. \diamond

Exercise 3.4. *Implement the sum function.*

The standard Python function called `sum` takes a list as argument and computes the sum of the elements in the list:

```
>>> sum([1,3,5,-5])
4
```

Implement your own version of `sum`. Name of program: `mysum.py`. ◇

Exercise 3.5. *Integrate a function by one trapezoid.*

An approximation to the integral of a function $f(x)$ over an interval $[a, b]$ can be found by first approximating $f(x)$ by the straight line that goes through the end points $(a, f(a))$ and $(b, f(b))$, and then finding the area under the straight line (which is the area of a trapezoid). The resulting formula becomes

$$\int_a^b f(x)dx \approx \frac{b-a}{2}(f(a) + f(b)). \quad (3.8)$$

Write a function `trapezint1(f, a, b)` that returns this approximation to the integral. The argument `f` is a Python implementation `f(x)` of the mathematical function $f(x)$.

Using (3.8), compute the following integrals: $\int_0^{\ln 3} e^x dx$, $\int_0^\pi \cos x dx$, $\int_0^\pi \sin x dx$, and $\int_0^{\pi/2} \sin x dx$. In each case, write out the error, i.e., the difference between the exact integral and the approximation (3.8). Make rough sketches of the trapezoid for each integral in order to understand how the method behaves in the different cases. Name of program file: `trapezint1.py`. ◇

Exercise 3.6. *Integrate a function by two trapezoids.*

We can easily improve the formula (3.8) from Exercise 3.5 by approximating the area under the function $f(x)$ by two equal-sized trapezoids. Derive a formula for this approximation and implement it in a function `trapezint2(f, a, b)`. Run the examples from Exercise 3.5 and see how much better the new formula is. Make sketches of the two trapezoids in each case. Name of program file: `trapezint2.py`. ◇

Exercise 3.7. *Derive the general Trapezoidal integration rule.*

A further improvement of the approximate integration method from Exercise 3.6 is to divide the area under the $f(x)$ curve into n equal-sized trapezoids. Based on this idea, derive the following formula for approximating the integral:

$$\int_a^b f(x)dx \approx \sum_{i=1}^n \frac{1}{2}h(f(x_{i-1}) + f(x_i)), \quad (3.9)$$

where h is the width of the trapezoids, $h = (b-a)/n$, and $x_i = a+ih$, $i = 0, \dots, n$, are the coordinates of the sides of the trapezoids. Figure 5.14b on page 255 visualizes the idea of the Trapezoidal rule.

Implement (3.9) in a Python function `trapezint(f, a, b, n)`. Run the examples from Exercise 3.5 with $n = 10$. Name of program file: `trapezint.py`.

Remark. Formula (3.9) is not the most common way of expressing the Trapezoidal integration rule. The reason is that $f(x_i)$ is evaluated twice, first in term i and then as $f(x_{i-1})$ in term $i + 1$. The formula can be further developed to avoid unnecessary evaluations of $f(x_i)$, which results in the standard form

$$\int_a^b f(x)dx \approx \frac{1}{2}h(f(a) + f(b)) + h \sum_{i=1}^{n-1} f(x_i). \quad (3.10)$$

◇

Exercise 3.8. *Derive the general Midpoint integration rule.*

The idea of the Midpoint rule for integration is to divide the area under the curve $f(x)$ into n equal-sized rectangles (instead of trapezoids as in Exercise 3.7). The height of the rectangle is determined by the value of f at the midpoint of the rectangle. Figure 5.14a on page 255 illustrates the idea. Compute the area of each rectangle, sum them up, and arrive at the formula for the Midpoint rule:

$$\int_a^b f(x)dx \approx h \sum_{i=1}^n f\left(a + \frac{1}{2}ih\right), \quad (3.11)$$

where $h = (b - a)/n$ is the width of each rectangle. Implement this formula in a Python function `midpointint(f, a, b, n)` and test the function on the Examples listed in Exercise 3.5. How do the errors in the Midpoint rule compare with those of the Trapezoidal rule (Exercise 3.7) for $n = 1$ and $n = 10$? Name of program file: `midpointint.py`. ◇

Exercise 3.9. *Compute the area of an arbitrary triangle.*

An arbitrary triangle can be described by the coordinates of its three vertices: (x_1, y_1) , (x_2, y_2) , (x_3, y_3) , numbered in a counterclockwise direction. The area of the triangle is given by the formula

$$A = \frac{1}{2}|x_2y_3 - x_3y_2 - x_1y_3 + x_3y_1 + x_1y_2 - x_2y_1|. \quad (3.12)$$

Write a function `area(vertices)` that returns the area of a triangle whose vertices are specified by the argument `vertices`, which is a nested list of the vertex coordinates. For example, computing the area of the triangle with vertex coordinates $(0, 0)$, $(1, 0)$, and $(0, 2)$ is done by

```
triangle1 = area([[0,0], [1,0], [0,2]])
# or
v1 = (0,0); v2 = (1,0); v3 = (0,2);
```

```

vertices = [v1, v2, v3]
triangle1 = area(vertices)

print 'Area of triangle is %.2f' % triangle1

```

Recall from Chapter 2.4 that extracting a coordinate like `x2` for use in the formula (3.12) is done by `vertices[1][0]`.

Test the `area` function on a triangle with known area. Name of program file: `area_triangle.py`. \diamond

Exercise 3.10. *Compute the length of a path.*

Some object is moving along a path in the plane. At n points of time we have recorded the corresponding (x, y) positions of the object: $(x_0, y_0), (x_1, y_1), \dots, (x_{n-1}, y_{n-1})$. The total length L of the path from (x_0, y_0) to (x_{n-1}, y_{n-1}) is the sum of all the individual line segments $((x_{i-1}, y_{i-1})$ to $(x_i, y_i), i = 1, \dots, n - 1)$:

$$L = \sum_{i=1}^{n-1} \sqrt{(x_i - x_{i-1})^2 + (y_i - y_{i-1})^2}. \quad (3.13)$$

Make a function `pathlength(x, y)` for computing L according to the formula. The arguments `x` and `y` hold all the x_0, \dots, x_{n-1} and y_0, \dots, y_{n-1} coordinates, respectively. Test the function on a triangular path with the four points $(1, 1), (2, 1), (1, 2)$, and $(1, 1)$. Name of program file: `pathlength.py`. \diamond

Exercise 3.11. *Approximate π .*

The value of π equals the circumference of a circle with radius $1/2$. Suppose we approximate the circumference by a polygon through $N + 1$ points on the circle. The length of this polygon can be found using the `pathlength` function from Exercise 3.10. Compute $N + 1$ points (x_i, y_i) along a circle with radius $1/2$ according to the formulas

$$x_i = \frac{1}{2} \cos(2\pi i/N), \quad y_i = \frac{1}{2} \sin(2\pi i/N), \quad i = 0, \dots, N.$$

Call the `pathlength` function and write out the error in the approximation of π for $N = 2^k, k = 2, 3, \dots, 10$. Name of program file: `pi_approx.py`. \diamond

Exercise 3.12. *Write various hello-world functions.*

Write three functions:

1. `hw1`, which takes no arguments and returns the string `'Hello, World!'`
2. `hw2`, which takes no arguments and returns nothing, but the string `'Hello, World!'` is printed in the terminal window
3. `hw3`, which takes two string arguments and prints these two arguments separated by a comma.

Use the following main program to test the three functions:

```
print hw1()
hw2()
hw3('Hello ', 'World!')
```

Name of program: `hw_func.py`. ◇

Exercise 3.13. *Approximate a function by a sum of sines.*

We consider the piecewise constant function

$$f(t) = \begin{cases} 1, & 0 < t < T/2, \\ 0, & t = T/2, \\ -1, & T/2 < t < T \end{cases} \quad (3.14)$$

Sketch this function on a piece of paper. One can approximate $f(t)$ by the sum

$$S(t; n) = \frac{4}{\pi} \sum_{i=1}^n \frac{1}{2i-1} \sin\left(\frac{2(2i-1)\pi t}{T}\right). \quad (3.15)$$

It can be shown that $S(t; n) \rightarrow f(t)$ as $n \rightarrow \infty$.

Write a Python function `S(t, n, T)` for returning the value of $S(t; n)$. Also write a Python `f(t, T)` for computing $f(t)$. Write out tabular information showing how the error $f(t) - S(t; n)$ varies with n and t for the case where $1, 3, 5, 10, 30, 100$ and $t = \alpha T$, with $T = 2\pi$, and $\alpha = 0.01, 0.25, 0.49$. Use the table to comment on how the quality of the approximation depends on α and n . Name of program file: `sinesum1.py`.

Remark. A sum of sine and/or cosine functions, as in (3.15), is called a *Fourier series*. Approximating a function by a Fourier series is a very important technique in science and technology. Exercise 5.30 asks for visualization of how well $S(t; n)$ approximates $f(t)$ for some values of n . ◇

Exercise 3.14. *Implement a Gaussian function.*

Make a Python function `gauss(x, m=0, s=1)` for computing the Gaussian function

$$f(x) = \frac{1}{\sqrt{2\pi} s} \exp\left[-\frac{1}{2} \left(\frac{x-m}{s}\right)^2\right],$$

Call `gauss(x)` and print out the result for $x \in [-5, 5]$ (say for 11 uniformly spaced x values). Name of program file: `Gaussian2.py`. ◇

Exercise 3.15. *Make a function of the formula in Exer. 1.12.*

Implement the formula (1.8) from Exercise 1.12 in a Python function with three arguments: `egg(M, To=20, Ty=70)`. The parameters ρ , K , c , and T_w can be set as local (constant) variables inside the function. Let

t be returned from the function. Compute t for a soft and hard boiled egg, of a small ($M = 47$ g) and large ($M = 67$ g) size, taken from the fridge ($T_o = 4$ C) and from a hot room ($T = 25$ C). Name of program file: `egg_func.py`. \diamond

Exercise 3.16. Write a function for numerical differentiation.

The formula

$$f'(x) \approx \frac{f(x+h) - f(x-h)}{2h} \quad (3.16)$$

can be used to find an approximate derivative of a mathematical function $f(x)$ if h is small. Write a function `diff(f, x, h=1E-6)` that returns the approximation (3.16) of the derivative of a mathematical function represented by a Python function `f(x)`.

Apply (3.16) to differentiate $f(x) = e^x$ at $x = 0$, $f(x) = e^{-2x^2}$ at $x = 0$, $f(x) = \cos x$ at $x = 2\pi$, and $f(x) = \ln x$ at $x = 1$. Use $h = 0.01$. In each case, write out the error, i.e., the difference between the exact derivative and the result of (3.16). Name of program file: `diff_f.py`. \diamond

Exercise 3.17. Make an adaptive Trapezoidal integration rule.

A problem with the Trapezoidal integration rule (3.9) is to decide how many trapezoids (n) to use in order to achieve a desired accuracy. Let E be the error in the Trapezoidal method, i.e., the difference between the exact integral and that produced by (3.9). We would like to prescribe a (small) tolerance ϵ and find an n such that $E \leq \epsilon$. This demands some expression for the error E involving the parameter n .

One can show that

$$E \leq \frac{1}{12}(b-a)h^2 \max_{x \in [a,b]} |f''(x)|. \quad (3.17)$$

The maximum of $|f''(x)|$ can be computed (approximately) by evaluating $f''(x)$ at a large number of points in $[a, b]$, taking the absolute value $|f''(x)|$, and finding the maximum value of these. You can use the `diff2` function from Chapter 3.1.9 to compute $f''(x)$.

With the computed estimate of $\max |f''(x)|$ we can find h from setting the worst case error in (3.17) (i.e., the right-hand side) equal to the desired tolerance:

$$\frac{1}{12}(b-a)h^2 \max_{x \in [a,b]} |f''(x)| = \epsilon$$

Solving with respect to h gives

$$h = \sqrt{12\epsilon} \left((b-a) \max_{x \in [a,b]} |f''(x)| \right)^{-1/2}. \quad (3.18)$$

With $n = (b-a)/h$ we have the n that corresponds to the desired accuracy ϵ .

Make a Python function `adaptive_trapezint(f, a, b, eps=1E-5)` for computing the integral $\int_a^b f(x)dx$ with an error less than or equal to `eps`. First compute n and then call `trapezint(f, a, b, n)` from Exercise 3.7. Name of program file: `adaptive_trapezint.py`.

A numerical method that applies an expression for the error to automatically compute a proper discretization parameter, like n (or h) here, is known as an *adaptive* numerical method. \diamond

Exercise 3.18. *Compute a polynomial via a product.*

Given $n + 1$ roots r_0, r_1, \dots, r_n of a polynomial $p(x)$ of degree $n + 1$, $p(x)$ can be computed by

$$p(x) = \prod_{i=0}^n (x - r_i) = (x - r_0)(x - r_1) \cdots (x - r_{n-1})(x - r_n). \quad (3.19)$$

Store the roots r_0, \dots, r_n in a list and make a loop that computes the product in (3.19). Test the program on a polynomial with roots $-1, 1$, and 2 . Name of program file: `polyprod.py`. \diamond

Exercise 3.19. *Implement the factorial function.*

The factorial of n is written as $n!$ and defined as

$$n! = n(n - 1)(n - 2) \cdots 2 \cdot 1, \quad (3.20)$$

with the special cases

$$1! = 1, \quad 0! = 1. \quad (3.21)$$

For example, $4! = 4 \cdot 3 \cdot 2 \cdot 1 = 24$, and $2! = 2 \cdot 1 = 2$. Write a function `fact(n)` that returns $n!$. Return 1 immediately if x is 1 or 0, otherwise use a loop to compute $n!$. Name of program file: `fact.py`.

Remark. You can import a ready-made factorial function by

```
>>> from math import factorial
>>> factorial(4)
24
```

\diamond

Exercise 3.20. *Compute velocity and acceleration from position data; one dimension.*

Let $x(t)$ be the position of an object moving along the x axis. The velocity $v(t)$ and acceleration $a(t)$ can be approximately computed by the formulas

$$v(t) \approx \frac{x(t + \Delta t) - x(t - \Delta t)}{2\Delta t}, \quad a(t) \approx \frac{x(t + \Delta t) - 2x(t) + x(t - \Delta t)}{\Delta t^2}, \quad (3.22)$$

where Δt is a small time interval. As $\Delta t \rightarrow 0$, the above formulas approach the first and second derivative of $x(t)$, which coincide with the well-known definitions of velocity and acceleration.

Write a function `kinematics(x, t, dt=1E-6)` for computing x , v , and a at time t , using the above formulas for v and a with Δt corresponding to dt . Let the function return x , v , and a . Test the function with the position function $x(t) = e^{-(t-4)^2}$ and the time point $t = 5$ (use $\Delta t = 10^{-5}$). Name of program: `kinematics1.py`. \diamond

Exercise 3.21. *Compute velocity and acceleration from position data; two dimensions.*

An object moves along a path in the xy plane such that at time t the object is located at the point $(x(t), y(t))$. The velocity vector in the plane, at time t , can be approximated as

$$v(t) \approx \left(\frac{x(t + \Delta t) - x(t - \Delta t)}{2\Delta t}, \frac{y(t + \Delta t) - y(t - \Delta t)}{2\Delta t} \right). \quad (3.23)$$

The acceleration vector in the plane, at time t , can be approximated as

$$a(t) \approx \left(\frac{x(t + \Delta t) - 2x(t) + x(t - \Delta t)}{\Delta t^2}, \frac{y(t + \Delta t) - 2y(t) + y(t - \Delta t)}{\Delta t^2} \right). \quad (3.24)$$

Here, Δt is a small time interval. As $\Delta t \rightarrow 0$, we have that $v(t) = (x'(t), y'(t))$ and $a(t) = (x''(t), y''(t))$.

Make a function `kinematics(x, y, t, dt=1E-6)` for computing the velocity and acceleration of the object according to the formulas above (t corresponds to t , and dt corresponds to Δt). The function should return three 2-tuples holding the position, the velocity, and the acceleration, all at time t . Test the function for the motion along a circle with radius R and absolute velocity $R\omega$: $x(t) = R \cos \omega t$ and $y(t) = R \sin \omega t$. Compute the velocity and acceleration for $t = 1$ using $R = 1$, $\omega = 2\pi$, and $\Delta t = 10^{-5}$. Name of program: `kinematics2.py`. \diamond

Exercise 3.22. *Find the max and min values of a function.*

Write a function `maxmin(f, a, b, n=1000)` for finding the maximum and minimum values of a mathematical function $f(x)$ in the interval between a and b . The following test program

```
from math import cos, pi
print maxmin(cos, -pi/2, 2*pi, 10001)
```

should write out `(1.0, -1.0)`.

The `maxmin` function can compute a set of n uniformly spaced coordinates between a and b stored in a list x , then compute f at the points in x and store the values in another list y . The Python functions `max(y)` and `min(y)` return the maximum and minimum values in the list y , respectively. Name of program file: `maxmin_f.py`. \diamond

Exercise 3.23. *Find the max and min elements in a list.*

Given a list a , the `max` function in Python's standard library computes the largest element in a : `max(a)`. Similarly, `min(a)` returns the

smallest element in `a`. The purpose of this exercise is to write your own `max` and `min` function. Use the following technique: Initialize a variable `max_elem` by the first element in the list, then visit all the remaining elements (`a[1:]`), compare each element to `max_elem`, and if greater, make `max_elem` refer to that element. Use a similar technique to compute the minimum element. Collect the two pieces of code in functions. Name of program file: `maxmin_list.py`. \diamond

Exercise 3.24. *Implement the Heaviside function.*

The following “step” function is known as the Heaviside function and is widely used in mathematics:

$$H(x) = \begin{cases} 0, & x < 0 \\ 1, & x \geq 0 \end{cases} \quad (3.25)$$

Implement $H(x)$ in a Python function `H(x)`. Test your implementation for $x = -\frac{1}{2}, 0, 10$. Name of program file: `Heaviside.py`. \diamond

Exercise 3.25. *Implement a smoothed Heaviside function.*

The Heaviside function (3.25) listed in Exercise 3.24 is discontinuous. It is in many numerical applications advantageous to work with a smooth version of the Heaviside function where the function itself and its first derivative are continuous. One such smoothed Heaviside function is

$$H_\epsilon(x) = \begin{cases} 0, & x < -\epsilon, \\ \frac{1}{2} + \frac{x}{2\epsilon} + \frac{1}{2\pi} \sin\left(\frac{\pi x}{\epsilon}\right), & -\epsilon \leq x \leq \epsilon \\ 1, & x > \epsilon \end{cases} \quad (3.26)$$

Implement $H_\epsilon(x)$ in a Python function `H_eps(x)`. Name of program file: `smoothed_Heaviside.py`. \diamond

Exercise 3.26. *Implement an indicator function.*

In many applications there is need for an indicator function, which is 1 over some interval and 0 elsewhere. More precisely, we define

$$I(x; L, R) = \begin{cases} 1, & x \in [L, R], \\ 0, & \text{elsewhere} \end{cases} \quad (3.27)$$

Make two Python implementations of such an indicator function, one with a direct test if $x \in [L, R]$ and one which expresses the indicator function in terms of Heaviside functions (3.25):

$$I(x; L, R) = H(x - L)H(R - x). \quad (3.28)$$

Name of program file: `indicator_func.py`. \diamond

Exercise 3.27. *Implement a piecewise constant function.*

Piecewise constant functions have a lot of important applications when modeling physical phenomena by mathematics. A piecewise con-

stant function can be defined as

$$f(x) = \begin{cases} v_0, & x \in [x_0, x_1], \\ v_1, & x \in [x_1, x_2], \\ \vdots & \\ v_i & x \in [x_i, x_{i+1}], \\ \vdots & \\ v_n & x \in [x_n, x_{n+1}] \end{cases} \quad (3.29)$$

That is, we have a union of non-overlapping intervals covering the domain $[x_0, x_{n+1}]$, and $f(x)$ is constant in each interval. One example is the function that is -1 on $[0, 1]$, 0 on $[1, 1.5]$, and 4 on $[1.5, 2]$, where we with the notation in (3.29) have $x_0 = 0$, $x_1 = 1$, $x_2 = 1.5$, $x_3 = 2$ and $v_0 = -1$, $v_1 = 0$, $v_3 = 4$.

Make a function `piecewise(x, data)` for evaluating a piecewise constant function as in (3.29) at the point x . The `data` object is a list of pairs (v_i, x_i) for $i = 0, \dots, n$. For example, `data` is `[(0, -1), (1, 0), (1.5, 4)]` in the example listed above. Since x_{n+1} is not a part of the `data` object, we have no means for detecting whether x is to the right of the last interval $[x_n, x_{n+1}]$, i.e., we must assume that the user of the `piecewise` function sends in an $x \leq x_{n+1}$. As always, make an additional function for testing that the `piecewise` function works well. Name of program file: `piecewise_constant1.py`. \diamond

Exercise 3.28. *Apply indicator functions.*

Implement piecewise constant functions, as defined in Exercise 3.27, by observing that

$$f(x) = \sum_{i=0}^n v_i I(x; x_i, x_{i+1}), \quad (3.30)$$

where $I(x; x_i, x_{i+1})$ is the indicator function from Exercise 3.26. Name of program file: `piecewise_constant2.py`. \diamond

Exercise 3.29. *Rewrite a mathematical function.*

We consider the $L(x; n)$ sum as defined in Chapter 3.1.4 and the corresponding function `L2(x, epsilon)` function from Chapter 3.1.6. The sum $L(x; n)$ can be written as

$$L(x; n) = \sum_{i=1}^n c_i, \quad c_i = \frac{1}{i} \left(\frac{x}{1+x} \right)^i.$$

Derive a relation between c_i and c_{i-1} ,

$$c_i = a c_{i-1},$$

where a is an expression involving i and x . This relation between c_i and c_{i-1} means that we can start with `term` as c_1 , and then in each pass of the loop implementing the sum $\sum_i c_i$ we can compute the next term c_i in the sum as

```
term = a*term
```

Rewrite the L2 function to make use of this alternative computation. Compare the new version with the original one to verify the implementation. Name of program file: `L2_recursive.py`. \diamond

Exercise 3.30. *Make a table for approximations of $\cos x$.*

The function $\cos(x)$ can be approximated by the sum

$$C(x; n) = \sum_{j=0}^n c_j, \quad (3.31)$$

where

$$c_j = -c_{j-1} \frac{x^2}{2j(2j-1)}, \quad j = 1, 2, \dots, n,$$

and $c_0 = 1$. Make a Python function for computing $C(x; n)$. (Hint: Represent c_j by a variable `term`, make updates `term = -term*...` inside a `for` loop, and accumulate the `term` variable in a variable for the sum.)

Also make a function for writing out a table of the errors in the approximation $C(x; n)$ of $\cos(x)$ for some x and n values given as arguments to the function. Let the x values run downward in the rows and the n values to the right in the columns. For example, a table for $x = 4\pi, 6\pi, 8\pi, 10\pi$ and $n = 5, 25, 50, 100, 200$ can look like

x	5	25	50	100	200
12.5664	1.61e+04	1.87e-11	1.74e-12	1.74e-12	1.74e-12
18.8496	1.22e+06	2.28e-02	7.12e-11	7.12e-11	7.12e-11
25.1327	2.41e+07	6.58e+04	-4.87e-07	-4.87e-07	-4.87e-07
31.4159	2.36e+08	6.52e+09	1.65e-04	1.65e-04	1.65e-04

Observe how the error increases with x and decreases with n . Name of program file: `cossum.py`. \diamond

Exercise 3.31. *Use `None` in keyword arguments.*

Consider the functions `L(x, n)` and `L2(x, epsilon)` from Chapter 3.1.6, whose program code is found in the file `lsum.py`. Let us make a more flexible function `L3` where we can either specify a tolerance `epsilon` or a number of terms `n` in the sum, and we can choose whether we want the sum to be returned or the sum and the number of terms. The latter set of return values is only meaningful with `epsilon` and not `n` is specified. The starting point for all this flexibility is to have some keyword arguments initialized to an “undefined” value that can be recognized:

```
def L3(x, n=None, epsilon=None, return_n=False):
```

You can test if `n` is given using the phrase⁶

```
if n is not None:
```

A similar construction can be used for `epsilon`. Print error messages for incompatible settings when `n` and `epsilon` are `None` (none given) or not `None` (both given). Name of program file: `L3_flexible.py`. ◇

Exercise 3.32. Write a sort function for a list of 4-tuples.

Below is a list of the nearest stars and some of their properties. The list elements are 4-tuples containing the name of the star, the distance from the sun in light years, the apparent brightness, and the luminosity. The apparent brightness is how bright the stars look in our sky compared to the brightness of Sirius A. The luminosity, or the true brightness, is how bright the stars would look if all were at the same distance compared to the Sun. The list data are found in the file `stars.list`, which looks as follows:

```
data = [
('Alpha Centauri A', 4.3, 0.26, 1.56),
('Alpha Centauri B', 4.3, 0.077, 0.45),
('Alpha Centauri C', 4.2, 0.00001, 0.00006),
("Barnard's Star", 6.0, 0.00004, 0.0005),
('Wolf 359', 7.7, 0.000001, 0.00002),
('BD +36 degrees 2147', 8.2, 0.0003, 0.006),
('Luyten 726-8 A', 8.4, 0.000003, 0.00006),
('Luyten 726-8 B', 8.4, 0.000002, 0.00004),
('Sirius A', 8.6, 1.00, 23.6),
('Sirius B', 8.6, 0.001, 0.003),
('Ross 154', 9.4, 0.00002, 0.0005),
]
```

The purpose of this exercise is to sort this list with respect to distance, apparent brightness, and luminosity.

To sort a list `data`, one can call `sorted(data)`, which returns the sorted list (cf. Table 2.1). However, in the present case each element is a 4-tuple, and the default sorting of such 4-tuples result in a list with the stars appearing in alphabetic order. We need to sort with respect to the 2nd, 3rd, or 4th element of each 4-tuple. If a tailored sort mechanism is necessary, we can provide our own sort function as a second argument to `sorted`, as in `sorted(data, mysort)`. Such a tailored sort function `mysort` must take two arguments, say `a` and `b`, and returns `-1` if `a` should become before `b` in the sorted sequence, `1` if `b` should become before `a`, and `0` if they are equal. In the present case, `a` and `b` are 4-tuples, so we need to make the comparison between the right elements in `a` and `b`. For example, to sort with respect to luminosity we write

⁶ One can also apply `if n != None`, but the `is` operator is most common (it tests if `n` and `None` are identical objects, not just objects with equal contents).

```
def mysort(a, b):
    if a[3] < b[3]:
        return -1
    elif a[3] > b[3]:
        return 1
    else:
        return 0
```

Write the complete program which initializes the data and writes out three sorted tables: star name versus distance, star name versus apparent brightness, and star name versus luminosity. Name of program file: `sorted_stars_data.py`. ◇

Exercise 3.33. *Find prime numbers.*

The *Sieve of Eratosthenes* is an algorithm for finding all prime numbers less than or equal to a number N . Read about this algorithm on Wikipedia and implement it in a Python program. Name of program file: `find_primes.py`. ◇

Exercise 3.34. *Find pairs of characters.*

Write a function `count_pairs(dna, pair)` that returns the number of occurrences of a pair of characters (`pair`) in a DNA string (`dna`). For example, calling the function with `dna` as `'ACTGCTATCCATT'` and `pair` as `'AT'` will return 2. Name of program file: `count_pairs.py`. ◇

Exercise 3.35. *Count substrings.*

This is an extension of Exercise 3.34: count how many times a certain string appears in another string. For example, the function returns 2 when called with the DNA string `'ACGTTACGGAACG'` and the substring `'ACG'`. Hint: For each match of the first character of the substring in the main string, check if the next n characters in the main string matches the substring, where n is the length of the substring. Use slices like `s` to pick out a substring of `s`. Name of program file: `count_substr.py`. ◇

Exercise 3.36. *Explain why a program works.*

The following program is quite similar to the program in Exercise 1.15:

```
def add(A, B):
    C = A + B
    return C

A = 3
B = 2
print add(A, B)
```

Explain how and thereby why the above program works. ◇

Exercise 3.37. *Resolve a problem with a function.*

Consider the following interactive session:

```

>>> def f(x):
...     if 0 <= x <= 2:
...         return x**2
...     elif 2 < x <= 4:
...         return 4
...     elif x < 0:
...         return 0
...
>>> f(2)
4
>>> f(5)
>>> f(10)

```

Why do we not get any output when calling `f(5)` and `f(10)`? (Hint: Save the `f` value in a variable `r` and write `print r`.) \diamond

Exercise 3.38. *Determine the types of some objects.*

Consider the following calls to the `makelist` function from page 92:

```

l1 = makelist(0, 100, 1)
l2 = makelist(0, 100, 1.0)
l3 = makelist(-1, 1, 0.1)
l4 = makelist(10, 20, 20)
l5 = makelist([1,2], [3,4], [5])
l6 = makelist((1,-1,1), ('myfile.dat', 'yourfile.dat'))
l7 = makelist('myfile.dat', 'yourfile.dat', 'herfile.dat')

```

Determine in each case what type of objects that become elements in the returned list and what the contents of `value` is after one pass in the loop.

Hint: Simulate the program by hand and check out in an interactive session what type of objects that result from the arithmetics. It is only necessary to simulate one pass of the loop to answer the questions. Some of the calls will lead to infinite loops if you really execute the `makelist` calls on a computer.

This exercise demonstrates that we can write a function and have in mind certain types of arguments, here typically `int` and `float` objects. However, the function can be used with other (originally unintended) arguments, such as lists and strings in the present case, leading to strange and irrelevant behavior (the problem here lies in the boolean expression `value <= stop` which is meaningless for some of the arguments). \diamond

Exercise 3.39. *Explain the difference between `if` and `elif`.*

Consider the following code:

```

def where1(x, y):
    if x > 0:
        print 'quadrant I or IV'
    if y > 0:
        print 'quadrant I or II'

def where2(x, y):
    if x > 0:
        print 'quadrant I or IV'

```

```

elif y > 0:
    print 'quadrant II'

for x, y in (-1, 1), (1, 1):
    where1(x,y)
    where2(x,y)

```

What is printed? ◇

Exercise 3.40. *Find an error in a program.*

Consider the following program for computing

$$f(x) = e^{rx} \sin(mx) + e^{sx} \sin(nx),$$

```

def f(x, m, n, r, s):
    return expsin(x, r, m) + expsin(x, s, n)

x = 2.5
print f(x, 0.1, 0.2, 1, 1)

from math import exp, sin

def expsin(x, p, q):
    return exp(p*x)*sin(q*x)

```

Running this code results in

```
NameError: global name 'expsin' is not defined
```

What is the problem? Simulate the program flow by hand or use the debugger to step from line to line. Correct the program. ◇

Exercise 3.41. *Find programming errors.*

What is wrong in the following code segments? Try first to find the errors in each case by visual inspection of the code. Thereafter, type in the code snippet and test it out in an interactive Python shell.

Case 1:

```

def f(x)
    return 1+x**2;

```

Case 2:

```

def f(x):
    term1 = 1
    term2 = x**2
    return term1 + term2

```

Case 3:

```

def f(x, a, b):
    return a + b*x

print f(1), f(2), f(3)

```

Case 4:

```
def f(x, w):
    from math import sin
    return sin(w*x)

f = 'f(x, w)'
w = 10
x = 0.1
print f(x, w)
```

Case 5:

```
from math import *

def log(message):
    print message

print 'The logarithm of 1 is', log(1)
```

Case 6:

```
import time

def print_CPU_time():
    print 'CPU time so far in the program:', time.clock()

print_CPU_time
```

◇

Recall our first program for evaluating the formula (1.2) on page 19 in Chapter 1:

```
C = 21
F = (9/5)*C + 32
print F
```

In this program, `C` is input data in the sense that `C` must be known before the program can perform the calculation of `F`. The results produced by the program, here `F`, constitute the output data.

Input data can be hardcoded in the program as we do above. That is, we explicitly set variables to specific values (`C = 21`). This programming style may be suitable for small programs. In general, however, it is considered good practice to let a user of the program provide input data when the program is running. There is then no need to modify the program itself when a new set of input data is to be explored¹.

This chapter starts with describing three different ways of reading data into a program: (i) letting the user answer questions in a dialog in the terminal window (Chapter 4.1), (ii) letting the user provide input on the command line (Chapter 4.2), and (iii) letting the user write input data in a graphical interface (Chapter 4.4). A fourth method is to read data from a file, but this topic is left for Chapter 6.

Even if your program works perfectly, wrong input data from the user may cause the program to produce wrong answers or even crash. Checking that the input data are correct is important, and Chapter 4.3 tells you how to do this with so-called exceptions.

The Python programming environment is organized as a big collection of modules. Organizing your own Python software in terms of

¹ Programmers know that any modification of the source code has a danger of introducing errors, so it is a good rule to change as little as possible in a program that works.

modules is therefore a natural and wise thing to do. Chapter 4.5 tells you how easy it is to make your own modules.

All the program examples from the present chapter are available in files in the `src/input` folder.

4.1 Asking Questions and Reading Answers

One of the simplest ways of getting data into a program is to ask the user a question, let the user type in an answer, and then read the text in that answer into a variable in the program. These tasks are done by calling a function with name `raw_input`. A simple example involving the temperature conversion program above will quickly show how to use this function.

4.1.1 Reading Keyboard Input

We may ask the user a question `C=?` and wait for the user to enter a number. The program can then read this number and store it in a variable `C`. These actions are performed by the statement

```
C = raw_input('C=? ')
```

The `raw_input` function always returns the user input as a string object. That is, the variable `C` above refers to a string object. If we want to compute with this `C`, we must convert the string to a floating-point number: `C = float(C)`. A complete program for reading `C` and computing the corresponding degrees in Fahrenheit now becomes

```
C = raw_input('C=? ')
C = float(C)
F = (9./5)*C + 32
print F
```

In general, the `raw_input` function takes a string as argument, displays this string in the terminal window, waits until the user presses the Return key, and then returns a string object containing the sequence of characters that the user typed in.

The program above is stored in a file called `c2f_qa.py` (the `qa` part of the name reflects “question and answer”). We can run this program in several ways, as described in Chapter 1.1.5 and Appendix H.1. The convention in this book is to indicate the execution by writing the program name only, but for a real execution you need to do more: write `run` before the program name in an interactive IPython session, or write `python` before the program name in a terminal session. Here is the execution of our sample program and the resulting dialog with the user:

Terminal

```
c2f_qa.py
C=? 21
69.8
```

In this particular example, the `raw_input` function reads the characters 21 from the keyboard and returns the string '21', which we refer to by the variable `C`. Then we create a new `float` object by `float(C)` and let the name `C` refer to this `float` object, with value 21.

You should now try out Exercises 4.1, 4.4, and 4.6 to make sure you understand how `raw_input` behaves.

4.1.2 The Magic “eval” Function

Python has a function `eval`, which takes a string as argument and evaluates this string as a Python expression. This functionality can be used to turn input into running code on the fly. To realize what it means, we invoke an interactive session:

```
>>> r = eval('1+2')
>>> r
3
>>> type(r)
<type 'int'>
```

The result of `r = eval('1+2')` is the same as if we had written `r = 1+2` directly:

```
>>> r = 1+2
>>> r
3
>>> type(r)
<type 'int'>
```

In general, any valid Python expression stored as text in a string `s` can be turned into Python code by `eval(s)`. Here is an example where the string to be evaluated is '2.5', which causes Python to see `r = 2.5` and make a `float` object:

```
>>> r = eval('2.5')
>>> r
2.5
>>> type(r)
<type 'float'>
```

If we put a string, enclosed in quotes, inside the expression string, the result is a string object:

```
>>>
>>> r = eval('"math programming"')
>>> r
'math programming'
>>> type(r)
<type 'str'>
```

Note that we must use two types of quotes: first double quotes to mark `math programming` as a string object and then another set of quotes, here single quotes (but we could also have used triple single quotes), to embed the text `"math programming"` inside a string. It does not matter if we have single or double quotes as inner or outer quotes, i.e., `'"...'` is the same as `"'...'"`, because `'` and `"` are interchangeable as long as a pair of either type is used consistently.

Writing just

```
>>> r = eval('math programming')
```

is the same as writing

```
>>> r = math programming
```

which is an invalid expression. Python will in this case think that `math` and `programming` are two (undefined) variables, and setting two variables next to each other with a space in between is invalid Python syntax. However,

```
>>> r = 'math programming'
```

is valid syntax, as this is how we initialize a string `r` in Python. To repeat, if we put the valid syntax `'math programming'` inside a string,

```
s = "'math programming'"
```

`eval(s)` will evaluate the text inside the double quotes as `'math programming'`, which yields a string.

Let us proceed with some more examples. We can put the initialization of a list inside quotes and use `eval` to make a list object:

```
>>> r = eval('[1, 6, 7.5]')
>>> r
[1, 6, 7.5]
>>> type(r)
<type 'list'>
```

Again, the assignment to `r` is equivalent to writing

```
>>> r = [1, 6, 7.5]
```

We can also make a tuple object by using tuple syntax (standard parentheses instead of brackets):

```
>>> r = eval('(-1, 1)')
>>> r
(-1, 1)
>>> type(r)
<type 'tuple'>
```

Another example reads

```
>>> from math import sqrt
>>> r = eval('sqrt(2)')
>>> r
1.4142135623730951
>>> type(r)
<type 'float'>
```

At the time we run `eval('sqrt(2)')`, this is the same as if we had written

```
>>> r = sqrt(2)
```

directly, and this is valid syntax only if the `sqrt` function is defined. Therefore, the import of `sqrt` prior to running `eval` is important in this example.

So, why is the `eval` function so useful? Recall the `raw_input` function, which always returns a string object, which we often must explicitly transform to a different type, e.g., an `int` or a `float`. Sometimes we want to avoid specifying one particular type. The `eval` function can then be of help: we feed the returned string from `raw_input` to `eval` and let the latter function interpret the string and convert it to the right object. An example may clarify the point. Consider a small program where we read in two values and add them. The values could be strings, floats, integers, lists, and so forth, as long as we can apply a `+` operator to the values. Since we do not know if the user supplies a string, float, integer, or something else, we just convert the input by `eval`, which means that the user's syntax will determine the type. The program goes as follows (`add_input.py`):

```
i1 = eval(raw_input('Give input: '))
i2 = eval(raw_input('Give input: '))
r = i1 + i2
print '%s + %s becomes %s\nwith value %s' % \
      (type(i1), type(i2), type(r), r)
```

Observe that we write out the two supplied values, together with the types of the values (obtained by `eval`), and the sum. Let us run the program with an integer and a real number as input:

Terminal

```
add_input.py
Give input: 4
Give input: 3.1
<type 'int'> + <type 'float'> becomes <type 'float'>
with value 7.1
```

The string `'4'`, returned by the first call to `raw_input`, is interpreted as an `int` by `eval`, while `'3.1'` gives rise to a `float` object.

Supplying two lists also works fine:

Terminal

```
add_input.py
Give input: [-1, 3.2]
```

```
Give input: [9,-2,0,0]
<type 'list'> + <type 'list'> becomes <type 'list'>
with value [-1, 3.2000000000000002, 9, -2, 0, 0]
```

If we want to use the program to add two strings, the strings must be enclosed in quotes for `eval` to recognize the texts as string objects (without the quotes, `eval` aborts with an error):

```
Terminal
add_input.py
Give input: 'one string'
Give input: " and another string"
<type 'str'> + <type 'str'> becomes <type 'str'>
with value one string and another string
```

Not all objects are meaningful to add:

```
Terminal
add_input.py
Give input: 3.2
Give input: [-1,10]
Traceback (most recent call last):
  File "add_input.py", line 3, in <module>
    r = i1 + i2
TypeError: unsupported operand type(s) for +: 'float' and 'list'
```

Another important example on the usefulness of `eval` is to turn formulas, given as input, into mathematics in the program. Consider the program

```
formula = raw_input('Give a formula involving x: ')
x = eval(raw_input('Give x: '))
from math import * # make all math functions available
result = eval(formula)
print '%s for x=%g yields %g' % (formula, x, result)
```

First, we ask the reader to provide a formula, e.g., $2*\sin(x)+1$. The result is a string object referred to by the `formula` variable. Then, we ask for an `x` value, typically a real number resulting in a float object. The key statement involves `eval(formula)`, which in the present example evaluates the expression $2*\sin(x)+1$. The `x` variable is defined, and the `sin` function is also defined because of the `import` statement. Let us try to run the program:

```
Terminal
eval_formula.py
Give a formula involving x: 2*sin(x)+1
Give x: 3.14
2*sin(x)+1 for x=3.14 yields 1.00319
```

Another important application of `eval` occurs in Chapter [4.2.1](#).

4.1.3 The Magic “exec” Function

Having presented `eval` for turning strings into Python code, we take the opportunity to also describe the related `exec` function to execute a string containing arbitrary Python code, not only an expression. Suppose the user can write a formula as input to the program, and that we want to turn this formula into a callable Python function. That is, writing `sin(x)*cos(3*x) + x**2` as the formula, we would like to get a function

```
def f(x):
    return sin(x)*cos(3*x) + x**2
```

This is easy with `exec`:

```
formula = raw_input('Write a formula involving x: ')
code = """
def f(x):
    return %s
""" % formula
exec(code)
```

If we respond with the text `sin(x)*cos(3*x) + x**2` to the question, `formula` will hold this text, which is inserted into the code string such that it becomes

```
"""
def f(x):
    return sin(x)*cos(3*x) + x**2
"""
```

Thereafter, `exec(code)` executes the code as if we had written the contents of the `code` string directly into the program by hand. With this technique, we can turn any user-given formula into a Python function!

Let us try out such code generation on the fly. We add a `while` loop to the previous code snippet defining `f(x)` such that we can provide `x` values and get `f(x)` evaluated:

```
x = 0
while x is not None:
    x = eval(raw_input('Give x (None to quit): '))
    if x is not None:
        print 'f(%g)=%g' % (x, f(x))
```

As long as we provide numbers as input for `x`, we evaluate the `f(x)` function, but when we provide the text `None`, `x` becomes a `None` object and the test in the `while` loop fails, i.e., the loop terminates. The complete program is found in the file `user_formula.py`. Here is a sample run:

Terminal

```
user_formula.py
Write a formula involving x: x**4 + x
Give x (None to quit): 1
```

```
f(1)=2
Give x (None to quit): 4
f(4)=260
Give x (None to quit): 2
f(2)=18
Give x (None to quit): None
```

4.1.4 Turning String Expressions into Functions

The examples in the previous section indicate that it can be handy to ask the user for a formula and turn that formula into a Python function. Since this operation is so useful, we have made a special tool that hides the technicalities. The tool is named `StringFunction` and works as follows:

```
>>> from scitools.StringFunction import StringFunction
>>> formula = 'exp(x)*sin(x)'
>>> f = StringFunction(formula) # turn formula into function f(x)
```

The `f` object now behaves as an ordinary Python function of `x`:

```
>>> f(0)
0.0
>>> f(pi)
2.8338239229952166e-15
>>> f(log(1))
0.0
```

Expressions involving other independent variables than `x` are also possible. Here is an example with the function $g(t) = Ae^{-at} \sin(\omega x)$:

```
g = StringFunction('A*exp(-a*t)*sin(omega*x)',
                  independent_variable='t',
                  A=1, a=0.1, omega=pi, x=0.5)
```

The first argument is the function formula, as before, but now we need to specify the name of the independent variable (`'x'` is default). The other parameters in the function (A , a , ω , and x) must be specified with values, and we use keyword arguments, consistent with the names in the function formula, for this purpose. Any of the parameters `A`, `a`, `omega`, and `x` can be changed later by calls like

```
g.set_parameters(omega=0.1)
g.set_parameters(omega=0.1, A=5, x=0)
```

Calling `g(t)` works as if `g` were a plain Python function of `t`, which “remembers” all the parameters `A`, `a`, `omega`, and `x`, and their values. You can use `pydoc` (see page 78) to bring up more documentation on the possibilities with `StringFunction`. Just run

```
pydoc scitools.StringFunction.StringFunction
```

A final important point is that `StringFunction` objects are as computationally efficient as hand-written Python functions².

4.2 Reading from the Command Line

Programs running on Unix computers usually avoid asking the user questions. Instead, input data are very often fetched from the *command line*. This section explains how we can access information on the command line in Python programs.

4.2.1 Providing Input on the Command Line

We look at the Celsius-Fahrenheit conversion program again. The idea now is to provide the Celsius input temperature as a *command-line argument* right after the program name. That is, we write the program name, here `c2f_cm1_v1.py`³, followed the Celsius temperature:

Terminal

```
c2f_cm1_v1.py 21
69.8
```

Inside the program we can fetch the text 21 as `sys.argv[1]`. The `sys` module has a list `argv` containing all the command-line arguments to the program, i.e., all the “words” appearing after the program name when we run the program. Here there is only one argument and it is stored with index 1. The first element in the `sys.argv` list, `sys.argv[0]`, is always the name of the program.

A command-line argument is treated as a text, so `sys.argv[1]` refers to a string object, in this case `'21'`. Since we interpret the command-line argument as a number and want to compute with it, it is necessary to explicitly convert the string to a `float` object. In the program we therefore write⁴

```
import sys
C = float(sys.argv[1])
F = 9.0*C/5 + 32
print F
```

As another example, consider the `ball2.py` program from Chapter 1.1.7. Instead of hardcoding the values of `v0` and `t` in the program we can read the two values from the command line:

² This property is quite remarkable in computer science – a string formula will in most other languages be much slower than if the formula were hardcoded inside a plain function.

³ The `cm1` part of the name is an abbreviation for “command line”, and `v1` denotes “version 1”, as usual.

⁴ We could write `9` instead of `9.0`, in the formula for `F`, since `C` is guaranteed to be `float`, but it is safer to write `9.0`. One could think of modifying the conversion of the command-line argument to `eval(sys.argv[1])`, and in that case `C` can easily be an `int`.

```
ball2i.py 0.6 5
1.2342
```

The two command-line arguments are now available as `sys.argv[1]` and `sys.argv[2]`. The complete `ball2i.py` program thus looks as

```
import sys
t = float(sys.argv[1])
v0 = float(sys.argv[2])
g = 9.81
y = v0*t - 0.5*g*t**2
print y
```

Our final example here concerns a program that can add two input objects (file `add_cml.py`, corresponding to `add_input.py` from Chapter 4.1.1):

```
import sys
i1 = eval(sys.argv[1])
i2 = eval(sys.argv[2])
r = i1 + i2
print '%s + %s becomes %s\nwith value %s' % \
      (type(i1), type(i2), type(r), r)
```

A key issue here is that we apply `eval` to the command-line arguments and thereby convert the strings into appropriate objects. Here is an example on execution:

```
add_cml.py 2 3.1
<type 'int'> + <type 'float'> becomes <type 'float'>
with value 5.1
```

4.2.2 A Variable Number of Command-Line Arguments

Let us make a program `addall.py` that adds all its command-line arguments. That is, we may run something like

```
addall.py 1 3 5 -9.9
The sum of 1 3 5 -9.9 is -0.9
```

The command-line arguments are stored in the sublist `sys.argv[1:]`. Each element is a string so we must perform a conversion to `float` before performing the addition. There are many ways to write this program. Let us start with version 1, `addall_v1.py`:

```
import sys
s = 0
for arg in sys.argv[1:]:
    number = float(arg)
    s += number
```

```
print 'The sum of ',
for arg in sys.argv[1:]:
    print arg,
print 'is ', s
```

The output is on one line, but built of several `print` statements (note the trailing comma which prevents the usual newline, cf. page 74). The command-line arguments must be converted to numbers in the first `for` loop because we need to compute with them, but in the second loop we only need to print them and then the string representation is appropriate.

The program above can be written more compactly if desired:

```
import sys
s = sum([float(x) for x in sys.argv[1:]])
print 'The sum of %s is %s' % (' '.join(sys.argv[1:]), s)
```

Here, we convert the list `sys.argv[1:]` to a list of `float` objects and then pass this list to Python's `sum` function for adding the numbers. The construction `S.join(L)` places all the elements in the list `L` after each other with the string `S` in between. The result here is a string with all the elements in `sys.argv[1:]` and a space in between, i.e., the text that originally appeared on the command line. Chapter 6.3.1 contains more information on `join` and many other very useful string operations.

4.2.3 More on Command-Line Arguments

Unix commands make heavy use of command-line arguments. For example, when you write `ls -s -t` to list the files in the current folder, you run the program `ls` with two command-line arguments: `-s` and `-t`. The former specifies that `ls` shall print the file name together with the size of the file, and the latter sorts the list of files according to their dates of last modification (the most recently modified files appear first). Similarly, `cp -r my new` for copying a folder tree `my` to a new folder tree `new` invokes the `cp` program with three command line arguments: `-r` (for recursive copying of files), `my`, and `new`. Most programming languages have support for extracting the command-line arguments given to a program.

Command-line arguments are separated by blanks. What if we want to provide a text containing blanks as command-line argument? The text containing blanks must then appear inside single or double quotes. Let us demonstrate this with a program that simply prints the command-line arguments:

```
import sys, pprint
pprint.pprint(sys.argv[1:])
```

Say this program is named `print_cml.py`. The execution

```
Terminal
```

```
print_cml.py 21 a string with blanks 31.3
['21', 'a', 'string', 'with', 'blanks', '31.3']
```

demonstrates that each word on the command line becomes an element in `sys.argv`. Enclosing strings in quotes, as in

```
Terminal
```

```
print_cml.py 21 "a string with blanks" 31.3
['21', 'a string with blanks', '31.3']
```

shows that the text inside the quotes becomes a single command line argument.

4.2.4 Option–Value Pairs on the Command Line

The examples on using command-line arguments so far require the user of the program to type all arguments in their right sequence, just as when calling a function with positional arguments. It would be very convenient to assign command-line arguments in the same way as we use keyword arguments. That is, arguments are associated with a name, their sequence can be arbitrary, and only the arguments where the default value is not appropriate need to be given. Such type of command-line arguments may have `-option value` pairs, where “option” is some name of the argument.

As usual, we shall use an example to illustrate how to work with `-option value` pairs. Consider the physics formula for the location $s(t)$ of an object at time t , if the object started at $s = s_0$ at $t = 0$ with a velocity v_0 , and thereafter was subject to a constant acceleration a :

$$s(t) = s_0 + v_0 t + \frac{1}{2} a t^2. \quad (4.1)$$

This formula requires four input variables: s_0 , v_0 , a , and t . We can make a program `location.py` that takes four options, `--s0`, `--v0`, `--a`, and `--t` on the command line. The program is typically run like this:

```
Terminal
```

```
location.py --t 3 --s0 1 --v0 1 --a 0.5
```

The sequence of `-option value` pairs is arbitrary. All options have a default value such that one does not have to specify all options on the command line.

All input variables should have sensible default values such that we can leave out the options for which the default value is suitable. For example, if $s_0 = 0$, $v_0 = 0$, $a = 1$, and $t = 1$ by default, and we only want to change t , we can run

Terminal

```
location.py --t 3
```

Python (v2.7) has a flexible and powerful module `argparse` for reading (parsing) `-option value` pairs on the command line. Using `argparse` consists of three steps. First, a parser object must be created:

```
import argparse
parser = argparse.ArgumentParser()
```

Second, we need to add the various command-line options,

```
parser.add_argument('--v0', '--initial_velocity', type=float,
                    default=0.0, help='initial velocity',
                    metavar='v')
parser.add_argument('--s0', '--initial_position', type=float,
                    default=0.0, help='initial position',
                    metavar='s')
parser.add_argument('--a', '--acceleration', type=float,
                    default=1.0, help='acceleration', metavar='a')
parser.add_argument('--t', '--time', type=float,
                    default=1.0, help='time', metavar='t')
```

The first arguments to `parser.add_argument` is the set of options that we want to associate with an input parameter. Optional arguments are the type, a default value, a help string, and a name for the value of the argument (`metavar`) in a usage string. The `argparse` module will automatically allow an option `-h` or `-help` that prints a usage string for all the registered options. By default, the type is `str`, the default value is `None`, the help string is empty, and `metavar` is the option in upper case without initial dash(es) by.

Third, we must read the command line arguments and interpret them:

```
args = parser.parse_args()
```

Through the `args` object we can extract the values of the various registered parameters: `args.v0`, `args.s0`, `args.a`, and `args.t`. The name of the parameter is determined by the first option to `parser.add_argument`, so writing

```
parser.add_argument('--initial_velocity', '--v0', type=float,
                    default=0.0, help='initial velocity')
```

will make the initial velocity value appear as `args.initial_velocity`. We can add the `dest` keyword to explicitly specify the name where the value is stored:

```
parser.add_argument('--initial_velocity', '--v0', dest='V0',
                    type=float, default=0, help='initial velocity')
```

Now, `args.V0` will retrieve the value of the initial velocity. In case we do not provide any default value, the value will be `None`.

Our example is completed either by evaluating `s` as

```
s = args.s0 + args.v0*t + 0.5*args.a*args.t**2
```

or by introducing new variables so that the formula aligns better with the mathematical notation:

```
s0 = args.s0; v0 = args.v0; a = args.a; t = args.t
s = s0 + v0*t + 0.5*a*t**2
```

A complete program for the example above is found in the file `location.py` in the `input` folder. Try to run it with the `-h` option to see an automatically generated explanation of legal command-line options.

Values on the command line involving mathematical symbols and functions, say `-v0 'pi/2'`, pose a problem with the code example above. The `argparse` module will in that case try to do `float('pi/2')` which does not work well. Changing `type=float` to `type=eval` is required to interpret the expression `pi/2`, but even `eval('pi/2')` fails since `pi` is not defined inside the `argparse` module. There are three remedies for this problem.

One can write a tailored function for converting a string value given on the command line to the desired object. For example,

```
def evalcmlarg(text):
    return eval(text)

parser.add_argument('--s0', '--initial_position', type=evalcmlarg,
                    default=0.0, help='initial position')
```

The file `location_v2.py` implements explicit type conversion. Note that `eval` is now taken in the programmer's namespace where (hopefully) `pi` or other symbols are imported.

More sophisticated conversions are possible. Say s_0 is specified in terms of a function of some parameter p , like $s_0 = (1 - p^2)$. We could then use a string for `-s0` and the `StringFunction` tool from Chapter 4.1.4 to turn the string into a function:

```
def toStringFunction4s0(text):
    from scitools.std import StringFunction
    return StringFunction(text, independent_variable='p')

parser.add_argument('--s0', '--initial_position',
                    type=toStringFunction4s0,
                    default='0.0', help='initial position')
```

Giving a command-line argument `-s0 'exp(-1.5) + 10(1-p**2)` results in `args.s0` being a `StringObject`, which we must evaluate for a p value:

```
s0 = args.s0
p = 0.05
...
s = s0(p) + v0*t + 0.5*a*t**2
```

The file `location_v3.py` contains the complete code.

Another alternative is to perform the right conversion explicitly for the arguments values after the values are read by the `parser` object. In the `parser.add_argument` calls we may treat argument types as strings, meaning that we replace `type=float` by set `type=str`, which is also the default choice of `type`. Recall that this requires specification of default values as strings too, say `'0'`:

```
parser.add_argument('--s0', '--initial_position', type=str,
                    default='0', help='initial position')
...
from math import *
args.v0 = eval(args.v0)
# or
v0 = eval(args.v0)

s0 = StringFunction(args.s0, independent_variable='p')
p = 0.5
...
s = s0(p) + v0*t + 0.5*a*t**2
```

Such code is found in the file `location_v4.py`. You can try out that program with the command-line arguments `-s0 'pi/2 + sqrt(p)' -v0 pi/4'`.

The final alternative is to write an `Action` class to handle the conversion from string to the right type. This is the preferred way to perform conversions and well described in the `argparse` documentation. We shall exemplify it here, but the technicalities involved require understanding of Chapter 9 (classes and inheritance). For the conversion from string to any object via `eval` we write

```
import argparse
from math import *

class ActionEval(argparse.Action):
    def __call__(self, parser, namespace, values,
                 option_string=None):
        setattr(namespace, self.dest, eval(values))
```

The command-line arguments supposed to be run through `eval` must then have an `action` parameter:

```
parser.add_argument('--v0', '--initial_velocity',
                    default=0.0, help='initial velocity',
                    action=ActionEval)
```

From string to function via `StringFunction` for the `-s0` argument we write

```

from scitools.std import StringFunction

class ActionStringFunction4s0(argparse.Action):
    def __call__(self, parser, namespace, values,
                 option_string=None):
        setattr(namespace, self.dest,
                StringFunction(values, independent_variable='p'))

```

A complete code appears in the file `location_v5.py`.

4.3 Handling Errors

Suppose we forget to provide a command-line argument to the `c2f_cml_v1.py` program from Chapter 4.2.1:

```

Terminal
c2f_cml_v1.py
Traceback (most recent call last):
  File "c2f_cml_v1.py", line 2, in ?
    C = float(sys.argv[1])
IndexError: list index out of range

```

Python aborts the program and shows an error message containing the line where the error occurred, the type of the error (`IndexError`), and a quick explanation of what the error is. From this information we deduce that the index 1 is out of range. Because there are no command-line arguments in this case, `sys.argv` has only one element, namely the program name. The only valid index is then 0.

For an experienced Python programmer this error message will normally be clear enough to indicate what is wrong. For others it would be very helpful if wrong usage could be detected by our program and a description of correct operation could be printed. The question is how to detect the error inside the program.

The problem in our sample execution is that `sys.argv` does not contain two elements (the program name, as always, plus one command-line argument). We can therefore test on the length of `sys.argv` to detect wrong usage: if `len(sys.argv)` is less than 2, the user failed to provide information on the C value. The new version of the program, `c2f_cml_v1.py`, starts with this if test:

```

if len(sys.argv) < 2:
    print 'You failed to provide Celsius degrees as input '\
          'on the command line!'
    sys.exit(1) # abort because of error
F = 9.0*C/5 + 32
print '%gC is %.1fF' % (C, F)

```

We use the `sys.exit` function to abort the program. Any argument different from zero signifies that the program was aborted due to an error, but the precise value of the argument does not matter so here

we simply choose it to be 1. If no errors are found, but we still want to abort the program, `sys.exit(0)` is used.

A more modern and flexible way of handling potential errors in a program is to *try* to execute some statements, and if something goes wrong, the program can detect this and jump to a set of statements that handle the erroneous situation as desired. The relevant program construction reads

```
try:
    <statements>
except:
    <statements>
```

If something goes wrong when executing the statements in the `try` block, Python raises what is known as an *exception*. The execution jumps directly to the `except` block whose statements can provide a remedy for the error. The next section explains the `try-except` construction in more detail through examples.

4.3.1 Exception Handling

To clarify the idea of exception handling, let us use a `try-except` block to handle the potential problem arising when our Celsius-Fahrenheit conversion program lacks a command-line argument:

```
import sys
try:
    C = float(sys.argv[1])
except:
    print 'You failed to provide Celsius degrees as input '\
        'on the command line!'
    sys.exit(1) # abort
F = 9.0*C/5 + 32
print '%gC is %.1fF' % (C, F)
```

The program is stored in the file `c2f_cm1_v3.py`. If the command-line argument is missing, the indexing `sys.argv[1]`, which has an invalid index 1, *raises an exception*. This means that the program jumps directly⁵ to the `except` block. In the `except` block, the programmer can retrieve information about the exception and perform statements to recover from the error. In our example, we know what the error can be, and therefore we just print a message and abort the program.

Suppose the user provides a command-line argument. Now, the `try` block is executed successfully, and the program neglects the `except` block and continues with the Fahrenheit conversion. We can try out the last program in two cases:

Terminal

```
c2f_cm1_v3.py
You failed to provide Celsius degrees as input on the command line!
```

⁵ This implies that `float` is not called, and `C` is not initialized with a value.

```
c2f_cml_v3.py 21
21C is 69.8F
```

In the first case, the illegal index in `sys.argv[1]` causes an exception to be raised, and we perform the steps in the `except` block. In the second case, the `try` block executes successfully, so we jump over the `except` block and continue with the computations and the printout of results.

For a user of the program, it does not matter if the programmer applies an `if` test or exception handling to recover from a missing command-line argument. Nevertheless, exception handling is considered a better programming solution because it allows more advanced ways to abort or continue the execution. Therefore, we adopt exception handling as our standard way of dealing with errors in the rest of this book.

Testing for a Specific Exception. Consider the assignment

```
C = float(sys.argv[1])
```

There are two typical errors associated with this statement: i) `sys.argv[1]` is illegal indexing because no command-line arguments are provided, and ii) the content in the string `sys.argv[1]` is not a pure number that can be converted to a `float` object. Python detects both these errors and raises an `IndexError` exception in the first case and a `ValueError` in the second. In the program above, we jump to the `except` block and issue the same message regardless of what went wrong in the `try` block. For example, when we indeed provide a command-line argument, but write it on an illegal form (21C), the program jumps to the `except` block and prints a misleading message:

```
Terminal
```

```
c2f_cml_v3.py 21C
You failed to provide Celsius degrees as input on the command line!
```

The solution to this problem is to branch into different `except` blocks depending on what type of exception that was raised in the `try` block (program `c2f_cml_v4.py`):

```
import sys
try:
    C = float(sys.argv[1])
except IndexError:
    print 'Celsius degrees must be supplied on the command line'
    sys.exit(1) # abort execution
except ValueError:
    print 'Celsius degrees must be a pure number, '\
          'not "%s"' % sys.argv[1]
    sys.exit(1)

F = 9.0*C/5 + 32
print '%gC is %.1fF' % (C, F)
```

Now, if we fail to provide a command-line argument, an `IndexError` occurs and we tell the user to write the `C` value on the command line. On the other hand, if the `float` conversion fails, because the command-line argument has wrong syntax, a `ValueError` exception is raised and we branch into the second `except` block and explain that the form of the given number is wrong:

Terminal

```
c2f_cml_v3.py 21C
Celsius degrees must be a pure number, not "21C"
```

Examples on Exception Types. List indices out of range lead to `IndexError` exceptions:

```
>>> data = [1.0/i for i in range(1,10)]
>>> data[9]
...
IndexError: list index out of range
```

Some programming languages (Fortran, C, C++, and Perl are examples) allow list indices outside the legal index values, and such unnoticed errors can be hard to find. Python always stops a program when an invalid index is encountered, unless you handle the exception explicitly as a programmer.

Converting a string to `float` is unsuccessful and gives a `ValueError` if the string is not a pure integer or real number:

```
>>> C = float('21 C')
...
ValueError: invalid literal for float(): 21 C
```

Trying to use a variable that is not initialized gives a `NameError` exception:

```
>>> print a
...
NameError: name 'a' is not defined
```

Division by zero raises a `ZeroDivisionError` exception:

```
>>> 3.0/0
...
ZeroDivisionError: float division
```

Writing a Python keyword illegally or performing a Python grammar error leads to a `SyntaxError` exception:

```
>>> forr d in data:
...     forr d in data:
...         ^
SyntaxError: invalid syntax
```

What if we try to multiply a string by a number?

```
>>> 'a string'*3.14
...
TypeError: can't multiply sequence by non-int of type 'float'
```

The `TypeError` exception is raised because the object types involved in the multiplication are wrong (`str` and `float`).

Digression. It might come as a surprise, but multiplication of a string and a number is legal if the number is an integer. The multiplication means that the string should be repeated the specified number of times. The same rule also applies to lists:

```
>>> '--'*10 # ten double dashes = 20 dashes
'-----'
>>> n = 4
>>> [1, 2, 3]*n
[1, 2, 3, 1, 2, 3, 1, 2, 3, 1, 2, 3]
>>> [0]*n
[0, 0, 0, 0]
```

The latter construction is handy when we want to create a list of `n` elements and later assign specific values to each element in a `for` loop.

4.3.2 Raising Exceptions

When an error occurs in your program, you may either print a message and use `sys.exit(1)` to abort the program, or you may raise an exception. The latter task is easy. You just write `raise E(message)`, where `E` can be a known exception type in Python and `message` is a string explaining what is wrong. Most often `E` means `ValueError` if the value of some variable is illegal, or `TypeError` if the type of a variable is wrong. You can also define your own exception types. An exception can be raised from any location in a program.

Example. In the program `c2f_cm1_v4.py` from page 154 we show how we can test for different exceptions and abort the program. Sometimes we see that an exception may happen, but if it happens, we want a more precise error message to help the user. This can be done by raising a new exception in an `except` block and provide the desired exception type and message.

Another application of raising exceptions with tailored error messages arises when input data are invalid. The code below illustrates how to raise exceptions in various cases.

We collect the reading of `C` and handling of errors a separate function:

```
def read_C():
    try:
        C = float(sys.argv[1])
    except IndexError:
        raise IndexError\
            ('Celsius degrees must be supplied on the command line')
```

```

except ValueError:
    raise ValueError\
        ('Celsius degrees must be a pure number, '\
         'not "%s"' % sys.argv[1])
# C is read correctly as a number, but can have wrong value:
if C < -273.15:
    raise ValueError('C=%g is a non-physical value!' % C)
return C

```

There are two ways of using the `read_C` function. The simplest is to call the function,

```
C = read_C()
```

Wrong input will now lead to a raw dump of exceptions, e.g.,

```

Terminal
c2f_cml_v5.py
Traceback (most recent call last):
  File "c2f_cml4.py", line 5, in ?
    raise IndexError\
IndexError: Celsius degrees must be supplied on the command line

```

New users of this program may become uncertain when getting raw output from exceptions, because words like `Traceback`, `raise`, and `IndexError` do not make much sense unless you have some experience with Python. A more user-friendly output can be obtained by calling the `read_C` function inside a `try-except` block, check for any exception (or better: check for `IndexError` or `ValueError`), and write out the exception message in a more nicely formatted form. In this way, the programmer takes complete control of how the program behaves when errors are encountered:

```

try:
    C = read_C()
except Exception, e:
    print e          # exception message
    sys.exit(1)     # terminate execution

```

`Exception` is the parent name of all exceptions, and `e` is an exception object. Nice printout of the exception message follows from a straight `print e`. Instead of `Exception` we can write `(ValueError, IndexError)` to test more specifically for two exception types we can expect from the `read_C` function:

```

try:
    C = read_C()
except (ValueError, IndexError), e:
    print e          # exception message
    sys.exit(1)     # terminate execution

```

After the `try-except` block above, we can continue with computing $F = 9 \cdot C / 5 + 32$ and print out `F`. The complete program is found in the file `c2f_cml.py`. We may now test the program's behavior when the input is wrong and right:

Terminal

```
c2f_cml.py
Celsius degrees must be supplied on the command line

c2f_cml.py 21C
Celsius degrees must be a pure number, not "21C"

c2f_cml.py -500
C=-500 is a non-physical value!

c2f_cml.py 21
21C is 69.8F
```

This program deals with wrong input, writes an informative message, and terminates the execution without annoying behavior.

Scattered `if` tests with `sys.exit` calls are considered a bad programming style compared to the use of nested exception handling as illustrated above. You should abort execution in the main program only, not inside functions. The reason is that the functions can be re-used in other occasions where the error can be dealt with differently. For instance, one may avoid abortion by using some suitable default data.

The programming style illustrated above is considered the best way of dealing with errors, so we suggest that you hereafter apply exceptions for handling potential errors in the programs you make, simply because this is what experienced programmers expect from your codes.

4.4 A Glimpse of Graphical User Interfaces

Maybe you find it somewhat strange that the usage of the programs we have made so far in this book – and the programs we will make in the rest of the book – are less graphical and intuitive than the computer programs you are used to from school or entertainment. Those programs are operated through some self-explaining graphics, and most of the things you want to do involve pointing with the mouse, clicking on graphical elements on the screen, and maybe filling in some text fields. The programs in this book, on the other hand, are run from the command line in a terminal window or inside IPython, and input is also given here in form of plain text.

The reason why we do not equip the programs in this book with graphical interfaces for providing input, is that such graphics is both complicated and tedious to write. If the aim is to solve problems from mathematics and science, we think it is better to focus on this part rather than large amounts of code that merely offers some “expected” graphical cosmetics for putting data into the program. Textual input from the command line is also quicker to provide. Also remember that the computational functionality of a program is obviously independent from the type of user interface, textual or graphic.

As an illustration, we shall now show a Celsius to Fahrenheit conversion program with a graphical user interface (often called a GUI). The GUI is shown in Figure 4.1. We encourage you to try out the graphical interface – the name of the program is `c2f_gui.py`. The complete program text is listed below.

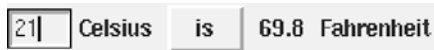

Fig. 4.1 Screen dump of the graphical interface for a Celsius to Fahrenheit conversion program. The user can type in the temperature in Celsius degrees, and when clicking on the “is” button, the corresponding Fahrenheit value is displayed.

```
from Tkinter import *
root = Tk()
C_entry = Entry(root, width=4)
C_entry.pack(side='left')
Cunit_label = Label(root, text='Celsius')
Cunit_label.pack(side='left')

def compute():
    C = float(C_entry.get())
    F = (9./5)*C + 32
    F_label.configure(text='%g' % F)

compute = Button(root, text=' is ', command=compute)
compute.pack(side='left', padx=4)

F_label = Label(root, width=4)
F_label.pack(side='left')
Funit_label = Label(root, text='Fahrenheit')
Funit_label.pack(side='left')

root.mainloop()
```

The goal of the forthcoming dissection of this program is to give a taste of how graphical user interfaces are coded. The aim is not to equip you with knowledge on how you can make such programs on your own.

A GUI is built of many small graphical elements, called *widgets*. The graphical window generated by the program above and shown in Figure 4.1 has five such widgets. To the left there is an *entry* widget where the user can write in text. To the right of this entry widget is a *label* widget, which just displays some text, here “Celsius”. Then we have a *button* widget, which when being clicked leads to computations in the program. The result of these computations is displayed as text in a *label* widget to the right of the button widget. Finally, to the right of this result text we have another *label* widget displaying the text “Fahrenheit”. The program must construct each widget and pack it correctly into the complete window. In the present case, all widgets are packed from left to right.

The first statement in the program imports functionality from the GUI toolkit `Tkinter` to construct widgets. First, we need to make a root widget that holds the complete window with all the other widgets.

This root widget is of type Tk. The first entry widget is then made and referred to by a variable `C_entry`. This widget is an object of type `Entry`, provided by the `Tkinter` module. Widgets constructions follow the syntax

```
variable_name = Widget_type(parent_widget, option1, option2, ...)
variable_name.pack(side='left')
```

When creating a widget, we must bind it to a *parent widget*, which is the graphical element in which this new widget is to be packed. Our widgets in the present program have the root widget as parent widget. Various widgets have different types of options that we can set. For example, the `Entry` widget has a possibility for setting the width of the text field, here `width=4` means that the text field is 4 characters wide. The `pack` statement is important to remember – without it, the widget remains invisible.

The other widgets are constructed in similar ways. The next fundamental feature of our program is how computations are tied to the event of clicking the button “is”. The `Button` widget has naturally a text, but more important, it binds the button to a function `compute` through the `command=compute` option. This means that when the user clicks the button “is”, the function `compute` is called. Inside the `compute` function we first fetch the Celsius value from the `C_entry` widget, using this widget’s `get` function, then we transform this string (everything typed in by the user is interpreted as text and stored in strings) to a `float` before we compute the corresponding Fahrenheit value. Finally, we can update (“configure”) the text in the `Label` widget `F_label` with a new text, namely the computed degrees in Fahrenheit.

A program with a GUI behaves differently from the programs we construct in this book. First, all the statements are executed from top to bottom, as in all our other programs, but these statements just construct the GUI and define functions. No computations are performed. Then the program enters a so-called *event loop*: `root.mainloop()`. This is an infinite loop that “listens” to user events, such as moving the mouse, clicking the mouse, typing characters on the keyboard, etc. When an event is recorded, the program starts performing associated actions. In the present case, the program waits for only one event: clicking the button “is”. As soon as we click on the button, the `compute` function is called and the program starts doing mathematical work. The GUI will appear on the screen until we destroy the window by click on the X up in the corner of the window decoration. More complicated GUIs will normally have a special “Quit” button to terminate the event loop.

In all GUI programs, we must first create a hierarchy of widgets to build up all elements of the user interface. Then the program enters an event loop and waits for user events. Lots of such events are registered

as actions in the program when creating the widgets, so when the user clicks on buttons, move the mouse into certain areas, etc., functions in the program are called and “things happen”.

Many books explain how to make GUIs in Python programs, see for instance [2, 3, 5, 7].

4.5 Making Modules

Sometimes you want to reuse a function from an old program in a new program. The simplest way to do this is to copy and paste the old source code into the new program. However, this is not good programming practice, because you then over time end up with multiple identical versions of the same function. When you want to improve the function or correct a bug, you need to remember to do the same update in all files with a copy of the function, and in real life most programmers fail to do so. You easily end up with a mess of different versions with different quality of basically the same code. Therefore, a golden rule of programming is to have one and only one version of a piece of code. All programs that want to use this piece of code must access one and only one place where the source code is kept. This principle is easy to implement if we create a module containing the code we want to reuse later in different programs.

You learned already in Chapter 1 how to import functions from Python modules. Now you will learn how to make your own modules. There is hardly anything to learn, because you just collect all the functions that constitute the module in one file, say with name `mymodule.py`. This file is automatically a module, with name `mymodule`, and you can import functions from this module in the standard way. Let us make everything clear in detail by looking at an example.

4.5.1 Example: Interest on Bank Deposits

The classical formula for the growth of money in a bank reads⁶

$$A = A_0 \left(1 + \frac{p}{360 \cdot 100} \right)^n, \quad (4.2)$$

where A_0 is the initial amount of money, and A is the present amount after n days with p percent annual interest rate. Equation (4.2) involves four parameters: A , A_0 , p , and n . We may solve for any of these, given the other three:

⁶ The formula applies the so-called Actual/360 convention where the rate per day is computed as $p/360$, while n counts the actual number of days the money is in the bank. See “[Day count convention](#)” in Wikipedia for detailed information and page 560 for a Python module for computing the number of days between two dates.

$$A_0 = A \left(1 + \frac{p}{360 \cdot 100} \right)^{-n}, \quad (4.3)$$

$$n = \frac{\ln \frac{A}{A_0}}{\ln \left(1 + \frac{p}{360 \cdot 100} \right)}, \quad (4.4)$$

$$p = 360 \cdot 100 \left(\left(\frac{A}{A_0} \right)^{1/n} - 1 \right). \quad (4.5)$$

Suppose we have implemented (4.2)–(4.5) in four functions:

```
from math import log as ln

def present_amount(A0, p, n):
    return A0*(1 + p/(360.0*100))**n

def initial_amount(A, p, n):
    return A*(1 + p/(360.0*100))**(-n)

def days(A0, A, p):
    return ln(A/A0)/ln(1 + p/(360.0*100))

def annual_rate(A0, A, n):
    return 360*100*((A/A0)**(1.0/n) - 1)
```

We want to make these functions available in a module, say with name `interest`, so that we can import functions and compute with them in a program. For example,

```
from interest import days
A0 = 1; A = 2; p = 5
n = days(A0, 2, p)
years = n/365.0
print 'Money has doubled after %.1f years' % years
```

How to make the `interest` module is described next.

4.5.2 Collecting Functions in a Module File

To make a module of the four functions `present_amount`, `initial_amount`, `days`, and `annual_rate`, we simply open an empty file in a text editor and copy the program code for all the four functions over to this file. This file is then automatically a Python module provided we save the file under any valid filename. The extension must be `.py`, but the module name is only the base part of the filename. In our case, the filename `interest.py` implies a module name `interest`. To use the `annual_rate` function in another program we simply write, in that program file,

```
from interest import annual_rate
```

or we can write

```
from interest import *
```

to import all four functions, or we can write

```
import interest
```

and access individual functions as `interest.annual_rate` and so forth.

Test Block. It is recommended to only have functions and not any statements outside functions in a module⁷. However, Python allows a special construction to let the file act both as a module with function definitions only *and* as an ordinary program that we can run, i.e., with statements that apply the functions and possibly write output. This two-fold “magic” consists of putting the application part after an `if` test of the form

```
if __name__ == '__main__':
    <block of statements>
```

The `__name__` variable is automatically defined in any module and equals the module name if the module file is imported in another program, or `__name__` equals the string `'__main__'` if the module file is run as a program. This implies that the `<block of statements>` part is executed if and only if we run the module file as a program. We shall refer to `<block of statements>` as the *test block* of a module.

Often, when modules are created from an ordinary program, the original main program is used as test block. The new module file then works as the old program, but with the new possibility of being imported in other programs. Let us write a little main program for testing the `interest` module. The idea is that we assign compatible values to the four parameters and check that given three of them, the functions calculate the remaining parameter in the correct way:

```
if __name__ == '__main__':
    A = 2.2133983053266699
    A0 = 2.0
    p = 5
    n = 730
    print 'A=%g (%g)\nA0=%g (%.1f)\nn=%d (%d)\np=%g (%.1f)' % \
          (present_amount(A0, p, n), A,
           initial_amount(A, p, n), A0,
           days(A0, A, p), n,
           annual_rate(A0, A, n), p)
```

Running the module file as a program is now possible:

⁷ The module file is executed from top to bottom during the import. With function definitions only in the module file, there will be no calculations or output from the import, just definitions of functions. This is the desirable behavior.

Terminal

```

interest.py
A=2.2134 (2.2134)
A0=2 (2.0)
n=730 (730)
p=5 (5.0)

```

The computed values appear after the equal sign, with correct values in parenthesis. We see that the program works well.

To test that the `interest.py` file also works as a module, invoke a Python shell and try to import a function and compute with it:

```

>>> from interest import present_amount
>>> present_amount(2, 5, 730)
2.2133983053266699

```

We have hence demonstrated that the file `interest.py` works both as a program and as a module.

Flexible Test Blocks. It is a good programming practice to let the test block do one or more of three things: (i) provide information on how the module or program is used, (ii) test if the module functions work properly, and (iii) offer interaction with users such that the module file can be applied as a useful program.

Instead of having a lot of statements in the test block, it might be better to collect the statements in separate functions, which then are called from the test block. A convention is to let these test or documentation functions have names starting with an underscore, because such names are not imported in other programs when doing a `from module import *` (normally we do not want to import test or documentation functions). In our example we may collect the verification statements above in a separate function and name this function `_verify` (observe the leading underscore). We also write the code a bit more explicit to better demonstrate how the module functions can be used:

```

def _verify():
    # Compatible values
    A = 2.2133983053266699; A0 = 2.0; p = 5; n = 730
    # Given three of these, compute the remaining one
    # and compare with the correct value (in parenthesis)
    A_computed = present_amount(A0, p, n)
    A0_computed = initial_amount(A, p, n)
    n_computed = days(A0, A, p)
    p_computed = annual_rate(A0, A, n)
    print 'A=%g (%g)\nA0=%g (%.1f)\nn=%d (%d)\np=%g (%.1f)' % \
        (A_computed, A, A0_computed, A0,
         n_computed, n, p_computed, p)

```

We may require a single command-line argument `verify` to run the verification. The test block can then be expressed as

```
if __name__ == '__main__':
    if len(sys.argv) == 2 and sys.argv[1] == 'verify':
        _verify()
```

To make a useful program, we may allow setting three parameters on the command line and let the program compute the remaining parameter. For example, running the program as

```
interest.py A0=2 A=1 n=1095
```

Terminal

should lead to a computation of p , in this case for seeing the size of the annual interest rate if the amount is to be doubled after three years.

How can we achieve the desired functionality? Since variables are already introduced and “initialized” on the command line, we could grab this text and execute it as Python code, either as three different lines or with semicolon between each assignment. This is easy⁸:

```
init_code = ''
for statement in sys.argv[1:]:
    init_code += statement + '\n'
exec(init_code)
```

For the sample run above with `A0=2 A=1 n=1095` on the command line, `init_code` becomes the string

```
A0=2
A=1
n=1095
```

Note that one cannot have spaces around the equal signs on the command line as this will break an assignment like `A0 = 2` into three command-line arguments, which will give rise to a `SyntaxError` in `exec(init_code)`. To tell the user about such errors, we execute `init_code` inside a `try-except` block:

```
try:
    exec(init_code)
except SyntaxError, e:
    print e
    print init_code
    sys.exit(1)
```

At this stage, our program has hopefully initialized three parameters in a successful way, and it remains to detect the remaining parameter to be computed. The following code does the work:

```
if 'A=' not in init_code:
    print 'A =', present_amount(A0, p, n)
elif 'A0=' not in init_code:
    print 'A0 =', initial_amount(A, p, n)
elif 'n=' not in init_code:
    print 'n =', days(A0, A, p)
```

⁸ The `join` function on page 285 in Chapter 6.3.1, see also page 147, is more elegant and avoids the loop.

```
elif 'p=' not in init_code:
    print 'p =', annual_rate(A0, A, n)
```

It may happen that the user of the program assign value to a parameter with wrong name or forget a parameter. In those cases we call one of our four functions with uninitialized arguments. Therefore, we should embed the code above in a `try-except` block. An uninitialized variable will lead to a `NameError`, while another frequent error is illegal values in the computations, leading to a `ValueError` exception. It is also a good habit to collect all the code related to computing the remaining, fourth parameter in a function for separating this piece of code from other parts of the module file:

```
def _compute_missing_parameter(init_code):
    try:
        exec(init_code)
    except SyntaxError, e:
        print e
        print init_code
        sys.exit(1)
    # Find missing parameter
    try:
        if 'A=' not in init_code:
            print 'A =', present_amount(A0, p, n)
        elif 'A0=' not in init_code:
            print 'A0 =', initial_amount(A, p, n)
        elif 'n=' not in init_code:
            print 'n =', days(A0, A , p)
        elif 'p=' not in init_code:
            print 'p =', annual_rate(A0, A, n)
    except NameError, e:
        print e
        sys.exit(1)
    except ValueError:
        print 'Illegal values in input:', init_code
        sys.exit(1)
```

If the user of the program fails to give any command-line arguments, we print a usage statement. Otherwise, we run a verification if the first command-line argument is “verify”, and else we run the missing parameter computation (i.e., the useful main program):

```
_filename = sys.argv[0]
_usage = """
Usage: %s A=10 p=5 n=730
Program computes and prints the 4th parameter'
(A, A0, p, or n)""" % _filename

if __name__ == '__main__':
    if len(sys.argv) == 1:
        print _usage
    elif len(sys.argv) == 2 and sys.argv[1] == 'verify':
        _verify()
    else:
        init_code = ''
        for statement in sys.argv[1:]:
            init_code += statement + '\n'
        _compute_missing_parameter(init_code)
```

Note leading underscores in variable names that are to be used locally in the `interest.py` file only.

It is also a good habit to include a doc string in the beginning of the module file. This doc string explains the purpose and use of the module:

```
"""
Module for computing with interest rates.
Symbols: A is present amount, A0 is initial amount,
n counts days, and p is the interest rate per year.

Given three of these parameters, the fourth can be
computed as follows:

    A = present_amount(A0, p, n)
    A0 = initial_amount(A, p, n)
    n = days(A0, A, p)
    p = annual_rate(A0, A, n)
"""
```

You can run the `pydoc` program to see a documentation of the new module, containing the doc string above and a list of the functions in the module: just write `pydoc interest` in a terminal window.

Now the reader is recommended to take a look at the actual file `interest.py` in `src/input` to see all elements of a good module file at once: doc string, set of functions, verification function, “main program function”, usage string, and test block.

4.5.3 Using Modules

Let us further demonstrate how to use the `interest.py` module in programs. For illustration purposes, we make a separate program file, say with name `test.py`, containing some computations:

```
from interest import days

# How many days does it take to double an amount when the
# interest rate is p=1,2,3,...14?
for p in range(1, 15):
    years = days(1, 2, p)/365.0
    print 'With p=%d%% it takes %.1f years to double the amount' \
          % (p, years)
```

There are different ways to import functions in a module, and let us explore these in an interactive session. The function call `dir()` will list all names we have defined, including imported names of variables and functions. Calling `dir(m)` will print the names defined inside a module with name `m`. First we start an interactive shell and call `dir()`

```
>>> dir()
['__builtins__', '__doc__', '__name__', '__package__']
```

These variables are always defined. Running the IPython shell will introduce several other standard variables too. Doing

```
>>> from interest import *
>>> dir()
[ ..., 'annual_rate', 'days', 'initial_amount',
'present_amount', 'ln', 'sys']
```

shows that we get our four functions imported, along with `ln` and `sys`. The latter two are needed in the `interest` module, but not necessarily in our new program `test.py`. Observe that none of the names with a leading underscore are imported. This demonstrates the importance of using a leading underscore in names for local variables and functions in a module: Names local to a module will then not pollute other programs or interactive sessions when a “star import” (`from module import *`) is performed.

Next we do

```
>>> import interest
>>> dir(interest)
['_builtins_', '__doc__', '__file__', '__name__', '__package__',
'_compute_missing_parameter', '_usage', '_verify',
'annual_rate', 'days', 'filename', 'initial_amount',
'ln', 'present_amount', 'sys']
```

All variables and functions defined or imported in the `interest.py` file are now visible, and we can access also functions and variables beginning with an underscore as long as we have the `interest.` prefix:

```
>>> interest._verify()
A=2.2134 (2.2134)
A0=2 (2.0)
n=730 (730)
p=5 (5.0)
>>> interest._filename
```

The `test.py` program works well as long as it is located in the same folder as the `interest.py` module. However, if we move `test.py` to another folder and run it, we get an error:

```
Terminal
```

```
test.py
Traceback (most recent call last):
  File "tmp.py", line 1, in <module>
    from interest import days
ImportError: No module named interest
```

Unless the module file resides in the same folder, we need to tell Python where to find our module. Python looks for modules in the folders contained in the list `sys.path`. A little program

```
import sys, pprint
pprint.pprint(sys.path)
```

prints out all these predefined module folders. You can now do one of two things:

1. Place the module file in one of the folders in `sys.path`.
2. Include the folder containing the module file in `sys.path`.

There are two ways of doing the latter task. Alternative 1 is to explicitly insert a new folder name in `sys.path` in the program that uses the module⁹:

```
modulefolder = '.././pymodules'
sys.path.insert(0, modulefolder)
```

Python searches the folders in the sequence they appear in the `sys.path` list so by inserting the folder name as the first list element we ensure that our module is found quickly, and in case there are other modules with the same name in other folders in `sys.path`, the one in `modulefolder` gets imported.

Alternative 2 is to specify the folder name in the `PYTHONPATH` environment variable. All folder names listed in `PYTHONPATH` are automatically included in `sys.path` when a Python program starts. On Mac and Linux systems, environment variables like `PYTHONPATH` are set in the `.bashrc` file in the home folder, typically as

```
export PYTHONPATH=$HOME/software/lib/pymodules:$PYTHONPATH
```

if `$HOME/software/lib/pymodules` is the folder containing Python modules.

4.6 Summary

4.6.1 Chapter Topics

Question and Answer Input. Prompting the user and reading the answer back into a variable is done by

```
var = raw_input('Give value: ')

```

The `raw_input` function returns a string containing the characters that the user wrote on the keyboard before pressing the Return key. It is necessary to convert `var` to an appropriate object (`int` or `float`, for instance) if we want to perform mathematical operations with `var`. Sometimes

```
var = eval(raw_input('Give value: '))

```

is a flexible and easy way of transforming the string to the right type of object (integer, real number, list, tuple, and so on). This last

⁹ In this sample path, the slashes are Unix specific. On Windows you must use backward slashes and a raw string. A better solution is to express the path as `os.path.join(os.pardir, os.pardir, 'mymodules')`. This will work on all platforms.

statement will not work, however, for strings unless the text is surrounded by quotes when written on the keyboard. A general conversion function that turns any text without quotes into the right object is `scitools.misc.str2obj`:

```
from scitools.misc import str2obj
var = str2obj(raw_input('Give value: '))
```

Typing, for example, 3 makes `var` refer to an `int` object, 3.14 results in a `float` object, [-1,1] results in a `list`, (1,3,5,7) in a `tuple`, and some text in the string (`str`) object 'some text' (run the program `str2obj_demo.py` to see this functionality demonstrated).

Getting Command-Line Arguments. The `sys.argv[1:]` list contains all the command-line arguments given to a program (`sys.argv[0]` contains the program name). All elements in `sys.argv` are strings. A typical usage is

```
parameter1 = float(sys.argv[1])
parameter2 = int(sys.argv[2])
parameter3 = sys.argv[3]           # parameter3 can be string
```

Using Option-Value Pairs. The `argparse` module is recommended for interpreting command-line arguments of the form `-option value`. A simple recipe with `argparse` reads

```
import argparse
parser = argparse.ArgumentParser()
parser.add_argument('--p1', '--parameter_1', type=float,
                    default=0.0, help='1st parameter')
parser.add_argument('--p2', type=float,
                    default=0.0, help='2nd parameter')

args = parser.parse_args()
p1 = args.p1
p2 = args.p2
```

On the command line we can provide any or all of these options:

```
--parameter_1 --p1 --p2
```

where each option must be succeeded by a suitable value. However, `argparse` is very flexible can easily handle options without values or (“positional”) command-line arguments without any option specifications.

Generating Code on the Fly. Calling `eval(s)` turns a string `s`, containing a Python expression, into code as if the contents of the string were written directly into the program code. The result of the following `eval` call is a `float` object holding the number 21.1:

```
>>> x = 20
>>> r = eval('x + 1.1')
>>> r
21.1
>>> type(r)
<type 'float'>
```

The `exec` function takes a string with arbitrary Python code as argument and executes the code. For example, writing

```
exec("""
def f(x):
    return %s
""" % sys.argv[1])
```

is the same as if we had hardcoded the (for the programmer unknown) contents of `sys.argv[1]` into a function definition in the program.

Turning String Formulas into Python Functions. Given a mathematical formula as a string, `s`, we can turn this formula into a callable Python function `f(x)` by

```
from scitools.StringFunction import StringFunction
# or
from scitools.std import *

f = StringFunction(s)
```

The string formula can contain parameters and an independent variable with another name than `x`:

```
Q_formula = 'amplitude*sin(w*t-phaseshift)'
Q = StringFunction(Q_formula, independent_variable='t',
                  amplitude=1.5, w=pi, phaseshift=0)
values1 = [Q(i*0.1) for t in range(10)]
Q.set_parameters(phaseshift=pi/4, amplitude=1)
values2 = [Q(i*0.1) for t in range(10)]
```

Functions of several independent variables are also supported:

```
f = StringFunction('x+y**2+A', independent_variables=('x', 'y'),
                  A=0.2)
x = 1; y = 0.5
print f(x, y)
```

Handling Exceptions. Testing for potential errors is done with `try-except` blocks:

```
try:
    <statements>
except ExceptionType1:
    <provide a remedy for ExceptionType1 errors>
except ExceptionType2, ExceptionType3, ExceptionType4:
    <provide a remedy for three other types of errors>
except:
    <provide a remedy for any other errors>
...
```

The most common exception types are `NameError` for an undefined variable, `TypeError` for an illegal value in an operation, and `IndexError` for a list index out of bounds.

Raising Exceptions. When some error is encountered in a program, the programmer can raise an exception:

```
if z < 0:
    raise ValueError('z=%s is negative - cannot do log(z)' % z)
r = log(z)
```

Modules. A module is created by putting a set of functions in a file. The filename (minus the required extension `.py`) is the name of the module. Other programs can import the module only if it resides in the same folder or in a folder contained in the `sys.path` list (see Chapter 4.5.3 for how to deal with this potential problem). Optionally, the module file can have a special `if` construct at the end, called test block, which tests the module or demonstrates its usage. The test block does not get executed when the module is imported in another program, only when the module file is run as a program.

4.6.2 Example: Bisection Root Finding

Problem. The summarizing example of this chapter concerns the implementation of the Bisection method for solving nonlinear equations of the form $f(x) = 0$ with respect to x . For example, the equation

$$x = 1 + \sin x$$

can be cast to the form $f(x) = 0$ if we move all terms to the left-hand side and define $f(x) = x - 1 - \sin x$. We say that x is a *root* of the equation $f(x) = 0$ if x is a solution of this equation. Nonlinear equations $f(x) = 0$ can have zero, one, many, or infinitely many roots.

Numerical methods for computing roots normally lead to approximate results only, i.e., $f(x)$ is not made exactly zero, but very close to zero. More precisely, an approximate root x fulfills $|f(x)| \leq \epsilon$, where ϵ is a small number. Methods for finding roots are of an iterative nature: We start with a rough approximation to a root and perform a repetitive set of steps that aim to improve the approximation. Our particular method for computing roots, the Bisection method, guarantees to find an approximate root, while other methods, such as the widely used Newton's method (see Appendix A.1.10), can fail to find roots.

The idea of the Bisection method is to start with an interval $[a, b]$ that contains a root of $f(x)$. The interval is halved at $m = (a + b)/2$, and if $f(x)$ changes sign in the left half interval $[a, m]$, one continues with that interval, otherwise one continues with the right half interval

$[m, b]$. This procedure is repeated, say n times, and the root is then guaranteed to be inside an interval of length $2^{-n}(b - a)$. The task is to write a program that implements the Bisection method and verify the implementation.

Solution. To implement the Bisection method, we need to translate the description in the previous paragraph to a precise algorithm that can be almost directly translated to computer code. Since the halving of the interval is repeated many times, it is natural to do this inside a loop. We start with the interval $[a, b]$, and adjust a to m if the root must be in the right half of the interval, or we adjust b to m if the root must be in the left half. In a language close to computer code we can express the algorithm precisely as follows:

```

for  $i = 0, 1, 2, \dots, n$ 
   $m = (a + b)/2$ 
  if  $f(a)f(m) \leq 0$  then
     $b = m$  (root is in left half)
  else
     $a = m$  (root is in right half)
  end if
end for
 $f(x)$  has a root in  $[a, b]$ 

```

Figure 4.2 displays graphically the first four steps of this algorithm for solving the equation $\cos(\pi x) = 0$, starting with the interval $[0, 0.82]$. The graphs are automatically produced by the program `bisection_movie.py`, which was run as follows for this particular example:

```

Terminal
bisection_movie.py 'cos(pi*x)' 0 0.82

```

The first command-line argument is the formula for $f(x)$, the next is a , and the final is b .

In the algorithm listed above, we recompute $f(a)$ in each `if`-test, but this is not necessary if a has not changed since the last $f(a)$ computations. It is a good habit in numerical programming to avoid redundant work. On modern computers the Bisection algorithm normally runs so fast that we can afford to do more work than necessary. However, if $f(x)$ is not a simple formula, but computed by comprehensive calculations in a program, the evaluation of f might take minutes or even hours, and reducing the number of evaluations in the Bisection algorithm is then very important. We will therefore introduce extra variables in the algorithm above to save an $f(m)$ evaluation in each iteration in the `for` loop:

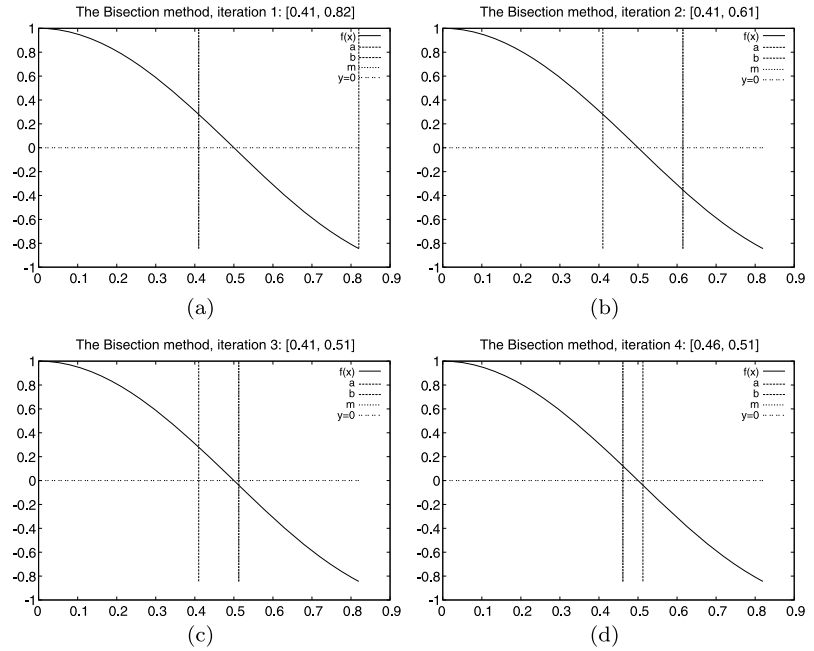

Fig. 4.2 Illustration of the first four iterations of the Bisection algorithm for solving $\cos(\pi x) = 0$. The vertical lines correspond to the current value of a and b .

```

fa = f(a)
for i = 0, 1, 2, ..., n
    m = (a + b)/2
    fm = f(m)
    if fafm ≤ 0 then
        b = m (root is in left half)
    else
        a = m (root is in right half)
        fa = fm
    end if
end for
f(x) has a root in [a, b]

```

To execute the algorithm above, we need to specify n . Say we want to be sure that the root lies in an interval of maximum extent ϵ . After n iterations the length of our current interval is $2^{-n}(b - a)$, if $[a, b]$ is the initial interval. The current interval is sufficiently small if

$$2^{-n}(b - a) = \epsilon,$$

which implies

$$n = -\frac{\ln \epsilon - \ln(b - a)}{\ln 2}. \quad (4.6)$$

Instead of calculating this n , we may simply stop the iterations when the length of the current interval is less than ϵ . The loop is then naturally implemented as a `while` loop testing on whether $b - a \leq \epsilon$. To make the algorithm more foolproof, we also insert a test to ensure that $f(x)$ really changes sign in the initial interval¹⁰.

Our final version of the Bisection algorithm now becomes

```

 $f_a = f(a)$ 
if  $f_a f(b) > 0$  then
    error:  $f$  does not change sign in  $[a, b]$ 
end if
 $i = 0$  (iteration counter)
while  $b - a > \epsilon$ :
     $i \leftarrow i + 1$ 
     $m = (a + b)/2$ 
     $f_m = f(m)$ 
    if  $f_a f_m \leq 0$  then
         $b = m$  (root is in left half)
    else
         $a = m$  (root is in right half)
         $f_a = f_m$ 
    end if
end while
if  $x$  is the real root,  $|x - m| < \epsilon$ 

```

This is the algorithm we aim to implement in a Python program.

A direct translation of the previous algorithm to a Python program should be quite a simple process:

```

eps = 1E-5
a, b = 0, 10

fa = f(a)
if fa*f(b) > 0:
    print 'f(x) does not change sign in [%g,%g]. ' % (a, b)
    sys.exit(1)

i = 0 # iteration counter
while b-a > eps:
    i += 1
    m = (a + b)/2.0
    fm = f(m)
    if fa*fm <= 0:
        b = m # root is in left half of [a,b]
    else:
        a = m # root is in right half of [a,b]
        fa = fm
    print 'Iteration %d: interval=[%g, %g]' % (i, a, b)

x = m # this is the approximate root

```

¹⁰ This guarantees a root in $[a, b]$. However, $f(a)f(b) < 0$ is not a necessary condition if there is an even number of roots in the initial interval.

```
print 'The root is', x, 'found in', i, 'iterations'
print 'f(%g)=%g' % (x, f(x))
```

This program is found in the file `bisection_v1.py`.

Verification. To verify the implementation in `bisection_v1.py` we choose a very simple $f(x)$ where we know the exact root. One suitable example is a linear function, $f(x) = 2x - 3$ such that $x = 3/2$ is the root of f . As can be seen from the source code above, we have inserted a `print` statement inside the `while` loop to control that the program really does the right things. Running the program yields the output

```
Iteration 1: interval=[0, 5]
Iteration 2: interval=[0, 2.5]
Iteration 3: interval=[1.25, 2.5]
Iteration 4: interval=[1.25, 1.875]
...
Iteration 19: interval=[1.5, 1.50002]
Iteration 20: interval=[1.5, 1.50001]
The root is 1.50000572205 found in 20 iterations
f(1.50001)=1.14441e-05
```

It seems that the implementation works. Further checks should include hand calculations for the first (say) three iterations and comparison of the results with the program.

Making a Function. The previous implementation of the bisection algorithm is fine for many purposes. To solve a new problem $f(x) = 0$ it is just necessary to change the `f(x)` function in the program. However, if we encounter solving $f(x) = 0$ in another program in another context, we must put the bisection algorithm into that program in the right place. This is simple in practice, but it requires some careful work, and it is easy to make errors. The task of solving $f(x) = 0$ by the bisection algorithm is much simpler and safer if we have that algorithm available as a function in a module. Then we can just import the function and call it. This requires a minimum of writing in later programs.

When you have a “flat” program as shown above, without basic steps in the program collected in functions, you should always consider dividing the code into functions. The reason is that parts of the program will be much easier to reuse in other programs. You save coding, and that is a good rule! A program with functions is also easier to understand, because statements are collected into logical, separate units, which is another good rule! In a mathematical context, functions are particularly important since they naturally split the code into general algorithms (like the bisection algorithm) and a problem-specific part (like a special choice of $f(x)$).

Shuffling statements in a program around to form a new and better designed version of the program is called *refactoring*. We shall now

refactor the `bisection_v1.py` program by putting the statements in the bisection algorithm in a function `bisection`. This function naturally takes $f(x)$, a , b , and ϵ as parameters and returns the found root, perhaps together with the number of iterations required:

```
def bisection(f, a, b, eps):
    fa = f(a)
    if fa*f(b) > 0:
        return None, 0

    i = 0 # iteration counter
    while b-a > eps:
        i += 1
        m = (a + b)/2.0
        fm = f(m)
        if fa*fm <= 0:
            b = m # root is in left half of [a,b]
        else:
            a = m # root is in right half of [a,b]
            fa = fm
    return m, i
```

After this function we can have a test program:

```
def f(x):
    return 2*x - 3 # one root x=1.5

eps = 1E-5
a, b = 0, 10
x, iter = bisection(f, a, b, eps)
if x is None:
    print 'f(x) does not change sign in [%g,%g].' % (a, b)
else:
    print 'The root is', x, 'found in', iter, 'iterations'
    print 'f(%g)=%g' % (x, f(x))
```

The complete code is found in file `bisection_v2.py`.

Making a Module. A motivating factor for implementing the bisection algorithm as a function `bisection` was that we could import this function in other programs to solve $f(x) = 0$ equations. However, if we do an import

```
from bisection_v2 import bisection
```

the import statement will run the main program in `bisection_v2.py`. We do not want to solve a particular $f(x) = 0$ example when we do an import of the `bisection` function! Therefore, we must put the main program in a test block (see Chapter 4.5.2). Even better is to collect the statements in the test program in a function and just call this function from the test block:

```
def _test():
    def f(x):
        return 2*x - 3 # one root x=1.5
```

```

eps = 1E-5
a, b = 0, 10
x, iter = bisection(f, a, b, eps)
if x is None:
    print 'f(x) does not change sign in [%g,%g].' % (a, b)
else:
    print 'The root is', x, 'found in', iter, 'iterations'
    print 'f(%g)=%g' % (x, f(x))

if __name__ == '__main__':
    _test()

```

The complete module with the `bisection` function, the `_test` function, and the test block is found in the file `bisection.py`.

Using the Module. Suppose you want to solve $x = \sin x$ using the bisection module. What do you have to do? First, you reformulate the equation as $f(x) = 0$, i.e., $x - \sin x = 0$ so that you identify $f(x) = x - \sin x$. Second, you make a file, say `x_eq_sinx.py`, where you import the `bisection` function, define the $f(x)$ function, and call `bisection`:

```

from bisection import bisection
from math import sin

def f(x):
    return x - sin(x)

root, iter = bisection(f, -2, 2, 1E-6)
print root

```

A Flexible Program for Solving $f(x) = 0$. The previous program hard-codes the input data $f(x)$, a , b , and ϵ to the bisection method for a specific equation. As we have pointed out in this chapter, a better solution is to let the user provide input data while the program is running. This approach avoids editing the program when a new equation needs to be solved (and as you remember, any change in a program has the danger of introducing new errors). We therefore set out to create a program that reads $f(x)$, a , b , and ϵ from the command-line. The expression for $f(x)$ is given as a text and turned into a Python function with aid of the `StringFunction` object from Chapter 4.1.4. The other parameters – a , b , and ϵ – can be read directly from the command line, but it can be handy to allow the user not to specify ϵ and provide a default value in the program instead.

The ideas above can be realized as follows in a new, general program for solving $f(x) = 0$ equations. The program is called `bisection_solver.py`:

```

import sys
usage = '%s f-formula a b [epsilon]' % sys.argv[0]
try:
    f_formula = sys.argv[1]

```

```

a = float(sys.argv[2])
b = float(sys.argv[3])
except IndexError:
    print usage; sys.exit(1)

try: # is epsilon given on the command-line?
    epsilon = float(sys.argv[4])
except IndexError:
    epsilon = 1E-6 # default value

from scitools.StringFunction import StringFunction
from math import * # might be needed for f_formula
f = StringFunction(f_formula)
from bisection import bisection

root, iter = bisection(f, a, b, epsilon)
if root == None:
    print 'The interval [%g, %g] does not contain a root' % (a, b)
    sys.exit(1)
print 'Found root %g\nof %s = 0 in [%g, %g] in %d iterations' % \
    (root, f_formula, a, b, iter)

```

Let us solve

1. $x = \tanh x$ with start interval $[-10, 10]$ and default precision ($\epsilon = 10^{-6}$),
2. $x^5 = \tanh(x^5)$ with start interval $[-10, 10]$ and default precision.

Both equations have one root $x = 0$.

Terminal

```

bisection_solver.py "x-tanh(x)" -10 10
Found root -5.96046e-07
of x-tanh(x) = 0 in [-10, 10] in 25 iterations

```

```

bisection_solver.py "x**5-tanh(x**5)" -10 10
Found root -0.0266892
of x**5-tanh(x**5) = 0 in [-10, 10] in 25 iterations

```

These results look strange. In both cases we halve the start interval $[-10, 10]$ 25 times, but in the second case we end up with a much less accurate root although the value of ϵ is the same. A closer inspection of what goes on in the bisection algorithm reveals that the inaccuracy is caused by round-off errors. As $a, b, m \rightarrow 0$, raising a small number to the fifth power in the expression for $f(x)$ yields a much smaller result. Subtracting a very small number $\tanh x^5$ from another very small number x^5 may result in a small number with wrong sign, and the sign of f is essential in the bisection algorithm. We encourage the reader to graphically inspect this behavior by running these two examples with the `bisection_plot.py` program using a smaller interval $[-1, 1]$ to better see what is going on. The command-line arguments for the `bisection_plot.py` program are `'x-tanh(x)' -1 1` and `'x**5-tanh(x**5)' -1 1`. The very flat area, in the latter case, where $f(x) \approx 0$ for $x \in [-1/2, 1/2]$ illustrates well that it is difficult to locate an exact root.

4.7 Exercises

Exercise 4.1. *Make an interactive program.*

Make a program that (i) asks the user for a temperature in Fahrenheit degrees and reads the number; (ii) computes the corresponding temperature in Celsius degrees; and (iii) prints out the temperature in the Celsius scale. Name of program file: `f2c_qa.py`. ◇

Exercise 4.2. *Read from the command line in Exer. 4.1.*

Modify the program from Exercise 4.1 such that the Fahrenheit temperature is read from the command line. Name of program file: `f2c_cml.py`. ◇

Exercise 4.3. *Use exceptions in Exer. 4.2.*

Extend the program from Exercise 4.2 with a `try-except` block to handle the potential error that the Fahrenheit temperature is missing on the command line. Name of program file: `f2c_cml_exc.py`. ◇

Exercise 4.4. *Read input from the keyboard.*

Make a program that asks for input from the user, applies `eval` to this input, and prints out the type of the resulting object and its value. Test the program by providing five types of input: an integer, a real number, a complex number, a list, and a tuple. Name of program file: `objects_qa.py`. ◇

Exercise 4.5. *Read input from the command line.*

Let a program store the result of applying the `eval` function to the first command-line argument. Print out the resulting object and its type. Run the program with different input: an integer, a real number, a list, and a tuple. (On Unix systems you need to surround the tuple expressions in quotes on the command line to avoid error message from the Unix shell.) Try the string `"this is a string"` as a command-line argument. Why does this string cause problems and what is the remedy? Name of program file: `objects_cml.py`. ◇

Exercise 4.6. *Prompt the user for input to a formula.*

Consider the simplest program for evaluating the formula $y(t) = v_0t - 0.5gt^2$:

```
v0 = 3; g = 9.81; t = 0.6
y = v0*t - 0.5*g*t**2
print y
```

Modify this code so that the program asks the user questions `t=?` and `v0=?`, and then gets `t` and `v0` from the user's input through the keyboard. Name of program file: `ball_qa.py`. ◇

Exercise 4.7. *Read command line input a formula.*

Modify the program listed in Exercise 4.6 such that `v0` and `t` are read from the command line. Name of program file: `ball_cml.py`. ◇

Exercise 4.8. *Make the program from Exer. 4.7 safer.*

The program from Exercise 4.7 reads input from the command line. Extend that program with exception handling such that missing command-line arguments are detected. In the `except IndexError` block, use the `raw_input` function to ask the user for missing input data. Name of program file: `ball_cml_qa.py`. ◇

Exercise 4.9. *Test more in the program from Exer. 4.7.*

Test if the `t` value read in the program from Exercise 4.7 lies between 0 and $2v_0/g$. If not, print a message and abort execution. Name of program file: `ball_cml_errorcheck.py`. ◇

Exercise 4.10. *Raise an exception in Exer. 4.9.*

Instead of printing an error message and aborting the program explicitly, raise a `ValueError` exception in the `if` test on legal `t` values in the program from Exercise 4.9. Include the legal interval for t in the exception message. Name of program file: `ball_cml_ValueError.py`. ◇

Exercise 4.11. *Compute the distance it takes to stop a car.*

A car driver, driving at velocity v_0 , suddenly puts on the brake. What braking distance d is needed to stop the car? One can derive, using Newton's second law of motion or a corresponding energy equation, that

$$d = \frac{1}{2} \frac{v_0^2}{\mu g}. \quad (4.7)$$

Make a program for computing d in (4.7) when the initial car velocity v_0 and the friction coefficient μ are given on the command line. Run the program for two cases: $v_0 = 120$ and $v_0 = 50$ km/h, both with $\mu = 0.3$ (μ is dimensionless). (Remember to convert the velocity from km/h to m/s before inserting the value in the formula!) Name of program file: `stopping_length.py`. ◇

Exercise 4.12. *Look up calendar functionality.*

The purpose of this exercise is to make a program which takes a date, consisting of year (4 digits), month (2 digits), and day (1–31) on the command line and prints the corresponding name of the weekday (Monday, Tuesday, etc.). Python has a module `calendar`, which you must look up in the Python Library Reference (see Chapter 2.6.3), for calculating the weekday of a date. Name of program file: `weekday.py`. ◇

Exercise 4.13. *Use the `StringFunction` tool.*

Make the program `user_formula.py` from Chapter 4.1.3 shorter by using the convenient `StringFunction` tool from Chapter 4.1.4. Name of program file: `user_formula2.py`. ◇

Exercise 4.14. *Extend a program from Ch. 4.2.1.*

How can you modify the `add_cml.py` program from the end of Chapter 4.1.2 such that it accepts input like `sqrt(2)` and `sin(1.2)`? In this case the output should be

```
<type 'float'> + <type 'float'> becomes <type 'float'>
with value 2.34625264834
```

Hint: Mathematical functions like `sqrt` and `sin` must be defined in the program before using `eval`. Furthermore, Unix (`bash`) does not like the parentheses on the command line so you need to put quotes around the command-line arguments. Name of program file: `add_cm12.py`. ◇

Exercise 4.15. *Why we test for specific exception types.*

The simplest way of writing a `try-except` block is to test for *any* exception, for example,

```
try:
    C = float(sys.argv[1])
except:
    print 'C must be provided as command-line argument'
    sys.exit(1)
```

Write the above statements in a program and test the program. What is the problem?

The fact that a user can forget to supply a command-line argument when running the program was the original reason for using a `try` block. Find out what kind of exception that is relevant for this error and test for this specific exception and re-run the program. What is the problem now? Correct the program. Name of program file: `cm1_exception.py`. ◇

Exercise 4.16. *Make a simple module.*

Make six conversion functions between temperatures in Celsius, Kelvin, and Fahrenheit: `C2F`, `F2C`, `C2K`, `K2C`, `F2K`, and `K2F`. Collect these functions in a module `convert_temp`. Import the module in an interactive Python shell and demonstrate some sample calls on temperature conversions. Name of program file: `convert_temp.py`. ◇

Exercise 4.17. *Make a useful main program for Exer. 4.16.*

Extend the module made in Exercise 4.16 with a main program in the test block. This main program should read the first command-line argument as a numerical value of a temperature and the second argument as a temperature scale: `C`, `K`, or `F`. Write out the temperature in the other two scales. For example, if `21.3 C` is given on the command line, the output should be `70.34 F 294.45 K`. Name of program file: `convert_temp2.py`. ◇

Exercise 4.18. *Make a module in Exer. 3.13.*

Collect the `f` and `S` functions in the program from Exercise 3.13 in a separate file such that this file becomes a module. Put the statements making the table (i.e., the main program from Exercise 3.13) in a separate function `table(n_values, alpha_values, T)`, and call this function only if the module file is run as a program (i.e., call `table` from a test block, see Chapter 4.5.2). Name of program file: `sinesum2.py`. ◇

Exercise 4.19. *Extend the module from Exer. 4.18.*

Extend the program from Exercise 4.18 such that T and a series of n and α values are read from the command line. The extended program should import the `table` function from the module `sinesum2` (and not copy any code from the module file). Name of program file: `sinesum3.py`.

◇

Exercise 4.20. *Use options and values in Exer. 4.19.*

Let the input to the program in Exercise 4.19 be option-value pairs of the type `-n`, `-alpha`, and `--T`, with sensible default values for these quantities set in the program. Apply the `argparse` module to read the command-line arguments. Name of program file: `sinesum4.py`.

◇

Exercise 4.21. *Check if mathematical identities hold on a computer.*

Because of round-off errors, it could happen that a mathematical rule like $(ab)^3 = a^3b^3$ does not hold (exactly) on a computer. The idea of this exercise is to check such identities for a large number of random numbers. We can make random numbers using the `random` module in Python:

```
import random
a = random.uniform(A, B)
b = random.uniform(A, B)
```

Here, `a` and `b` will be random numbers which are always larger than or equal to `A` and smaller than `B`.

Make a program that reads the number of tests to be performed from the command line. Set `A` and `B` to fixed values (say `-100` and `100`). Perform the test in a loop. Inside the loop, draw random numbers `a` and `b` and test if the two mathematical expressions `(a*b)**3` and `a**3*b**3` are equivalent. Count the number of failures of equivalence and write out the percentage of failures at the end of the program.

Duplicate the code segment outlined above to also compare the expressions `a/b` and `1/(b/a)`. Name of program file: `math_identities_failures.py`.

◇

Exercise 4.22. *Improve input to the program in Exer. 4.21.*

The purpose of this exercise is to extend the program from Exercise 4.21 to handle a large number of mathematical identities. Make a function `equal(expr1, expr2, A, B, n=500)` which tests if the mathematical expressions `expr1` and `expr2`, given as strings and involving numbers `a` and `b`, are exactly equal (`eval(expr1) == eval(expr2)`) for `n` random choices of numbers `a` and `b` in the interval between `A` and `B`. Return the percentage of failures. Make a module with the `equal` function and a test block which feeds the `equal` function with arguments read from the command line. Run the module file as a program to test the two identities from Exercise 4.21. Also test the identities $e^{a+b} = e^a e^b$

and $\ln a^b = b \ln a$ (take `a` from `math` `import *` in the module file so that mathematical functions like `exp` and `log` are defined). Name of program file: `math_identities_failures_cml.py`. \diamond

Exercise 4.23. *Apply the program from Exer. 4.22.*

Import the `equal` function from the module made in Exercise 4.22 and test the three identities from Exercise 4.21 in addition to the following identities:

- $a - b$ and $-(b - a)$
- a/b and $1/(b/a)$
- $(ab)^4$ and a^4b^4
- $(a + b)^2$ and $a^2 + 2ab + b^2$
- $(a + b)(a - b)$ and $a^2 - b^2$
- e^{a+b} and $e^a e^b$
- $\ln a^b$ and $b \ln a$
- $\ln ab$ and $\ln a + \ln b$
- ab and $e^{\ln a + \ln b}$
- $1/(1/a + 1/b)$ and $ab/(a + b)$
- $a(\sin^2 b + \cos^2 b)$ and a
- $\sinh(a + b)$ and $(e^a e^b - e^{-a} e^{-b})/2$
- $\tan(a + b)$ and $\sin(a + b)/\cos(a + b)$
- $\sin(a + b)$ and $\sin a \cos b + \sin b \cos a$

Store all the expressions in a list of 2-tuples, where each 2-tuple contains two mathematically equivalent expressions as strings which can be sent to the `eval` function. Make a nicely formatted table with a pair of equivalent expressions at each line followed by the failure rate. Try out `A=0` and `B=1` as well as `A=-1E+7` and `B=1E+7`. Does the failure rate seem to depend on the magnitude of the numbers a and b ? Name of program file: `math_identities_failures_table.py`.

Remark. Exercise 4.21 can be solved by a simple program, but if you want to check 17 identities the present exercise demonstrates how important it is to be able to automate the process via the `equal` function and two nested loops over a list of equivalent expressions. \diamond

Exercise 4.24. *Compute the binomial distribution.*

Consider an uncertain event where there are two outcomes only, typically success or failure. Flipping a coin is an example: The outcome is uncertain and of two types, either head (can be considered as success) or tail (failure). Throwing a die can be another example, if (e.g.) getting a six is considered success and all other outcomes represent failure. Let the probability of success be p and that of failure $1 - p$. If we perform n experiments, where the outcome of each experiment does not depend on the outcome of previous experiments, the probability of getting success x times (and failure $n - x$ times) is given by

$$B(x, n, p) = \frac{n!}{x!(n-x)!} p^x (1-p)^{n-x}. \quad (4.8)$$

This formula (4.8) is called the binomial distribution. The expression $x!$ is the factorial of x as defined in Exercise 3.19. Implement (4.8) in a function `binomial(x, n, p)`. Make a module containing this `binomial` function. Include a test block at the end of the module file. Name of program file: `binomial_distribution.py`. \diamond

Exercise 4.25. *Apply the binomial distribution.*

Use the module from Exercise 4.24 to make a program for solving the problems below.

1. What is the probability of getting two heads when flipping a coin five times?

This probability corresponds to $n = 5$ events, where the success of an event means getting head, which has probability $p = 1/2$, and we look for $x = 2$ successes.

2. What is the probability of getting four ones in a row when throwing a die?

This probability corresponds to $n = 4$ events, success is getting one and has probability $p = 1/6$, and we look for $x = 4$ successful events.

3. Suppose cross country skiers typically experience one ski break in one out of 120 competitions. Hence, the probability of breaking a ski can be set to $p = 1/120$. What is the probability b that a skier will experience a ski break during five competitions in a world championship?

This question is a bit more demanding than the other two. We are looking for the probability of 1, 2, 3, 4 or 5 ski breaks, so it is simpler to ask for the probability c of *not* breaking a ski, and then compute $b = 1 - c$. Define “success” as breaking a ski. We then look for $x = 0$ successes out of $n = 5$ trials, with $p = 1/120$ for each trial. Compute b .

Name of program file: `binomial_problems.py`. \diamond

Exercise 4.26. *Compute probabilities with the Poisson distribution.*

Suppose that over a period of t_m time units, a particular uncertain event happens (on average) νt_m times. The probability that there will be x such events in a time period t is approximately given by the formula

$$P(x, t, \nu) = \frac{(\nu t)^x}{x!} e^{-\nu t}. \quad (4.9)$$

This formula is known as the Poisson distribution¹¹. An important assumption is that all events are independent of each other and that

¹¹ It can be shown that (4.9) arises from (4.8) when the probability p of experiencing the event in a small time interval t/n is $p = \nu t/n$ and we let $n \rightarrow \infty$.

the probability of experiencing an event does not change significantly over time.

Implement (4.9) in a function `Poisson(x, t, nu)`, and make a program that reads x , t , and ν from the command line and writes out the probability $P(x, t, \nu)$. Use this program to solve the problems below.

1. Suppose you are waiting for a taxi in a certain street at night. On average, 5 taxis pass this street every hour at this time of the night. What is the probability of not getting a taxi after having waited 30 minutes?

Since we have 5 events in a time period of $t_m = 1$ hour, $\nu t_m = \nu = 5$. The sought probability is then $P(0, 1/2, 5)$. Compute this number.

What is the probability of having to wait two hours for a taxi?

If 8 people need two taxis, that is the probability that two taxis arrive in a period of 20 minutes?

2. In a certain location, 10 earthquakes have been recorded during the last 50 years. What is the probability of experiencing exactly three earthquakes over a period of 10 years in this area? What is the probability that a visitor for one week does not experience any earthquake?

With 10 events over 50 years we have $\nu t_m = \nu \cdot 50$ years = 10 events, which implies $\nu = 1/5$ event per year. The answer to the first question of having $x = 3$ events in a period of $t = 10$ years is given directly by (4.9). The second question asks for $x = 0$ events in a time period of 1 week, i.e., $t = 1/52$ years, so the answer is $P(0, 1/52, 1/5)$.

3. Suppose that you count the number of misprints in the first versions of the reports you write and that this number shows an average of six misprints per page. What is the probability that a reader of a first draft of one of your reports reads six pages without hitting a misprint?

Assuming that the Poisson distribution can be applied to this problem, we have “time” t_m as 1 page and $\nu \cdot 1 = 6$, i.e., $\nu = 6$ events (misprints) per page. The probability of no events in a “period” of six pages is $P(0, 6, 6)$. \diamond

Lists are introduced in Chapter 2 to store “tabular data” in a convenient way. An array is an object that is very similar to a list, but less flexible and computationally much more efficient. When using the computer to perform mathematical calculations, we often end up with a huge amount of numbers and associated arithmetic operations. Storing numbers in lists may in such contexts lead to slow programs, while arrays can make the programs run much faster. This may not be very important for the mathematical problems in this book, since most of the programs usually finish execution within a few seconds. Nevertheless, in more advanced applications of mathematics, especially the applications met in industry and science, computer programs may run for weeks and months. Any clever idea that reduces the execution time to days or hours is therefore paramount¹.

This chapter gives a brief introduction to arrays – how they are created and what they can be used for. Array computing usually ends up with a lot of numbers. It may be very hard to understand what these numbers mean by just looking at them. Since the human is a visual animal, a good way to understand numbers is to visualize them. In this chapter we concentrate on visualizing curves that reflect functions of one variable, e.g., curves of the form $y = f(x)$. A synonym for curve is graph, and the image of curves on the screen is often called a plot. We will use arrays to store the information about points along the curve. It is fair to say that array computing demands visualization and visualization demands arrays.

¹ Many may argue that programmers of mathematical software have traditionally paid too much attention to efficiency and smart program constructs. The resulting software often becomes very hard to maintain and extend. In this book we advocate a focus on clear, well-designed, and easy-to-understand programs that work correctly. Optimization for speed should always come as a second step in program development.

All program examples in this chapter can be found as files in the folder `src/plot`.

5.1 Vectors

This section gives a brief introduction to the vector concept, assuming that you have heard about vectors in the plane and maybe vectors in space before. This background will be valuable when we start to work with arrays and curve plotting.

5.1.1 The Vector Concept

Some mathematical quantities are associated with a set of numbers. One example is a point in the plane, where we need two coordinates (real numbers) to describe the point mathematically. Naming the two coordinates of a particular point as x and y , it is common to use the notation (x, y) for the point. That is, we group the numbers inside parentheses. Instead of symbols we might use the numbers directly: $(0, 0)$ and $(1.5, -2.35)$ are also examples of coordinates in the plane.

A point in three-dimensional space has three coordinates, which we may name x_1 , x_2 , and x_3 . The common notation groups the numbers inside parentheses: (x_1, x_2, x_3) . Alternatively, we may use the symbols x , y , and z , and write the point as (x, y, z) , or numbers can be used instead of symbols.

From high school you may have a memory of solving two equations with two unknowns. At the university you will soon meet problems that are formulated as n equations with n unknowns. The solution of such problems contains n numbers that we can collect inside parentheses and number from 1 to n : $(x_1, x_2, x_3, \dots, x_{n-1}, x_n)$.

Quantities such as (x, y) , (x, y, z) , or (x_1, \dots, x_n) are known as *vectors* in mathematics. A visual representation of a vector is an arrow that goes from the origin to a point. For example, the vector (x, y) is an arrow that goes from $(0, 0)$ to the point with coordinates (x, y) in the plane. Similarly, (x, y, z) is an arrow from $(0, 0, 0)$ to the point (x, y, z) in three-dimensional space.

Mathematicians found it convenient to introduce spaces with higher dimension than three, because when we have a solution of n equations collected in a vector (x_1, \dots, x_n) , we may think of this vector as a point in a space with dimension n , or equivalently, an arrow that goes from the origin $(0, \dots, 0)$ in n -dimensional space to the point (x_1, \dots, x_n) . Figure 5.1 illustrates a vector as an arrow, either starting at the origin, or at any other point. Two arrows/vectors that have the same direction and the same length are mathematically equivalent.

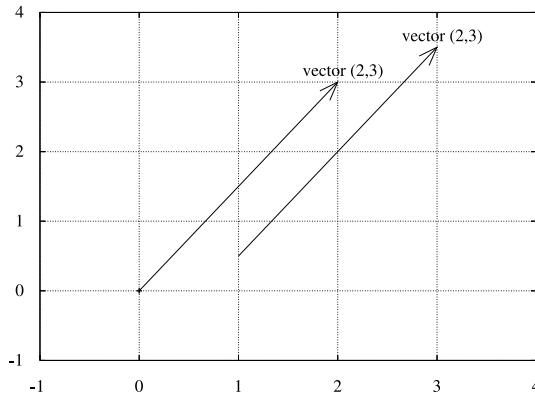

Fig. 5.1 A vector $(2, 3)$ visualized in the standard way as an arrow from the origin to the point $(2, 3)$, and mathematically equivalently, as an arrow from $(1, \frac{1}{2})$ (or any point (a, b)) to $(3, 3\frac{1}{2})$ (or $(a + 2, b + 3)$).

We say that (x_1, \dots, x_n) is an n -vector or a vector with n components. Each of the numbers x_1, x_2, \dots is a component or an element. We refer to the first component (or element), the second component (or element), and so forth.

A Python program may use a list or tuple to represent a vector:

```
v1 = [x, y]           # list of variables
v2 = (-1, 2)         # tuple of numbers
v3 = (x1, x2, x3)    # tuple of variables
from math import exp
v4 = [exp(-i*0.1) for i in range(150)]
```

While v_1 and v_2 are vectors in the plane and v_3 is a vector in three-dimensional space, v_4 is a vector in a 150-dimensional space, consisting of 150 values of the exponential function. Since Python lists and tuples have 0 as the first index, we may also in mathematics write the vector (x_1, x_2) as (x_0, x_1) . This is not at all common in mathematics, but makes the distance from a mathematical description of a problem to its solution in Python shorter.

It is impossible to visually demonstrate how a space with 150 dimensions looks like. Going from the plane to three-dimensional space gives a rough feeling of what it means to add a dimension, but if we forget about the idea of a visual perception of space, the mathematics is very simple: Going from a 4-dimensional vector to a 5-dimensional vector is just as easy as adding an element to a list of symbols or numbers.

5.1.2 Mathematical Operations on Vectors

Since vectors can be viewed as arrows having a length and a direction, vectors are extremely useful in geometry and physics. The velocity of a car has a magnitude and a direction, so has the acceleration, and the

position of a car is a point² which is also a vector. An edge of a triangle can be viewed as a line (arrow) with a direction and length.

In geometric and physical applications of vectors, mathematical operations on vectors are important. We shall exemplify some of the most important operations on vectors below. The goal is not to teach computations with vectors, but more to illustrate that such computations are defined by mathematical rules³. Given two vectors, (u_1, u_2) and (v_1, v_2) , we can add these vectors according to the rule:

$$(u_1, u_2) + (v_1, v_2) = (u_1 + v_1, u_2 + v_2). \quad (5.1)$$

We can also subtract two vectors using a similar rule:

$$(u_1, u_2) - (v_1, v_2) = (u_1 - v_1, u_2 - v_2). \quad (5.2)$$

A vector can be multiplied by a number. This number, called a below, is usually denoted as a *scalar*:

$$a \cdot (v_1, v_2) = (av_1, av_2). \quad (5.3)$$

The inner product, also called dot product, or scalar product, of two vectors is a number⁴:

$$(u_1, u_2) \cdot (v_1, v_2) = u_1v_1 + u_2v_2. \quad (5.4)$$

There is also a *cross product* defined for 2-vectors or 3-vectors, but we do not list the cross product formula here.

The length of a vector is defined by

$$\|(v_1, v_2)\| = \sqrt{(v_1, v_2) \cdot (v_1, v_2)} = \sqrt{v_1^2 + v_2^2}. \quad (5.5)$$

The same mathematical operations apply to n -dimensional vectors as well. Instead of counting indices from 1, as we usually do in mathematics, we now count from 0, as in Python. The addition and subtraction of two vectors with n components (or elements) read

$$(u_0, \dots, u_{n-1}) + (v_0, \dots, v_{n-1}) = (u_0 + v_0, \dots, u_{n-1} + v_{n-1}), \quad (5.6)$$

$$(u_0, \dots, u_{n-1}) - (v_0, \dots, v_{n-1}) = (u_0 - v_0, \dots, u_{n-1} - v_{n-1}). \quad (5.7)$$

² A car is of course not a mathematical point, but when studying the acceleration of a car, it suffices to view it as a point. In other occasions, e.g., when simulating a car crash on a computer, the car may be modeled by a large number (say 10^6) of connected points.

³ You might recall many of the formulas here from high school mathematics or physics. The really new thing in this chapter is that we show how rules for vectors in the plane and in space can easily be extended to vectors in n -dimensional space.

⁴ From high school mathematics and physics you might recall that the inner or dot product also can be expressed as the product of the lengths of the two vectors multiplied by the cosine of the angle between them. We will not make use of this formula.

Multiplication of a scalar a and a vector (v_0, \dots, v_{n-1}) equals

$$(av_0, \dots, av_{n-1}). \quad (5.8)$$

The inner or dot product of two n -vectors is defined as

$$(u_0, \dots, u_{n-1}) \cdot (v_0, \dots, v_{n-1}) = u_0v_0 + \dots + u_{n-1}v_{n-1} = \sum_{j=0}^{n-1} u_jv_j. \quad (5.9)$$

Finally, the length $\|v\|$ of an n -vector $v = (v_0, \dots, v_{n-1})$ is

$$\begin{aligned} \sqrt{(v_0, \dots, v_{n-1}) \cdot (v_0, \dots, v_{n-1})} &= (v_0^2 + v_1^2 + \dots + v_{n-1}^2)^{\frac{1}{2}} \\ &= \left(\sum_{j=0}^{n-1} v_j^2 \right)^{\frac{1}{2}}. \end{aligned} \quad (5.10)$$

5.1.3 Vector Arithmetics and Vector Functions

In addition to the operations on vectors in Chapter 5.1.2, which you might recall from high school mathematics, we can define other operations on vectors. This is very useful for speeding up programs. Unfortunately, the forthcoming vector operations are hardly treated in textbooks on mathematics, yet these operations play a significant role in mathematical software, especially in computing environment such as Matlab, Octave, Python, and R.

Applying a mathematical function of one variable, $f(x)$, to a vector is defined as a vector where f is applied to each element. Let $v = (v_0, \dots, v_{n-1})$ be a vector. Then

$$f(v) = (f(v_0), \dots, f(v_{n-1})).$$

For example, the sine of v is

$$\sin(v) = (\sin(v_0), \dots, \sin(v_{n-1})).$$

It follows that squaring a vector, or the more general operation of raising the vector to a power, can be defined as applying the operation to each element:

$$v^b = (v_0^b, \dots, v_{n-1}^b).$$

Another operation between two vectors that arises in computer programming of mathematics is the “asterisk” multiplication, defined as

$$u * v = (u_0v_0, u_1v_1, \dots, u_{n-1}v_{n-1}). \quad (5.11)$$

Adding a scalar to a vector or array can be defined as adding the scalar to each component. If a is a scalar and v a vector, we have

$$a + v = (a + v_0, \dots, a + v_{n-1}).$$

A compound vector expression may look like

$$v^2 * \cos(v) * e^v + 2. \tag{5.12}$$

How do we calculate this expression? We use the normal rules of mathematics, working our way, term by term, from left to right, paying attention to the fact that powers are evaluated before multiplications and divisions, which are evaluated prior to addition and subtraction. First we calculate v^2 , which results in a vector we may call u . Then we calculate $\cos(v)$ and call the result p . Then we multiply $u * p$ to get a vector which we may call w . The next step is to evaluate e^v , call the result q , followed by the multiplication $w * q$, whose result is stored as r . Then we add $r + 2$ to get the final result. It might be more convenient to list these operations after each other:

1. $u = v^2$
2. $p = \cos(v)$
3. $w = u * p$
4. $q = e^v$
5. $r = w * q$
6. $s = r + 2$

Writing out the vectors u , w , p , q , and r in terms of a general vector $v = (v_0, \dots, v_{n-1})$ (do it!) shows that the result of the expression (5.12) is the vector

$$(v_0^2 \cos(v_0)e^{v_0} + 2, \dots, v_{n-1}^2 \cos(v_{n-1})e^{v_{n-1}} + 2).$$

That is, component no. i in the result vector equals the number arising from applying the formula (5.12) to v_i , where the $*$ multiplication is ordinary multiplication between two numbers.

We can, alternatively, introduce the function

$$f(x) = x^2 \cos(x)e^x + 2$$

and use the result that $f(v)$ means applying f to each element in v . The result is the same as in the vector expression (5.12).

In Python programming it is important for speed (and convenience too) that we can apply functions of one variable, like $f(x)$, to vectors. What this means mathematically is something we have tried to explain in this subsection. Doing Exercises 5.5 and 5.6 may help to grasp the ideas of vector computing, and with more programming experience you will hopefully discover that vector computing is very useful. It is not

necessary to have a thorough understanding of vector computing in order to proceed with the next sections.

Arrays are used to represent vectors in a program, but one can do more with arrays than with vectors. Until Chapter 5.7 it suffices to think of arrays as the same as vectors in a program.

5.2 Arrays in Python Programs

This section introduces array programming in Python, but first we create some lists and show how arrays differ from lists.

5.2.1 Using Lists for Collecting Function Data

Suppose we have a function $f(x)$ and want to evaluate this function at a number of x points x_0, x_1, \dots, x_{n-1} . We could collect the n pairs $(x_i, f(x_i))$ in a list, or we could collect all the x_i values, for $i = 0, \dots, n-1$, in a list and all the associated $f(x_i)$ values in another list. We learned how to create such lists in Chapter 2, but as a review, we present the relevant program statements in an interactive session:

```
>>> def f(x):
...     return x**3           # sample function
...
>>> n = 5                    # no of points along the x axis
>>> dx = 1.0/(n-1)          # spacing between x points in [0,1]
>>> xlist = [i*dx for i in range(n)]
>>> ylist = [f(x) for x in xlist]
>>> pairs = [[x, y] for x, y in zip(xlist, ylist)]
```

Here we have used list comprehensions for achieving compact code. Make sure that you understand what is going on in these list comprehensions (you are encouraged to write the same code using standard for loops and appending new list elements in each pass of the loops).

The list elements consist of objects of the same type: any element in `pairs` is a list of two `float` objects, while any element in `xlist` or `ylist` is a `float`. Lists are more flexible than that, because an element can be an object of any type, e.g.,

```
mylist = [2, 6.0, 'tmp.ps', [0,1]]
```

Here `mylist` holds an `int`, a `float`, a string, and a list. This combination of diverse object types makes up what is known as *heterogeneous* lists. We can also easily remove elements from a list or add new elements anywhere in the list. This flexibility of lists is in general convenient to have as a programmer, but in cases where the elements are of the same type and the number of elements is fixed, arrays can be used instead. The benefits of arrays are faster computations, less memory

demands, and extensive support for mathematical operations on the data. Because of greater efficiency and mathematical convenience, arrays will be used to a large extent in this book. The great use of arrays is also prominent in other programming environments such as Matlab, Octave, and R, for instance. Lists will be our choice instead of arrays when we need the flexibility of adding or removing elements or when the elements may be of different object types.

5.2.2 Basics of Numerical Python Arrays

An *array* object can be viewed as a variant of a list, but with the following assumptions and features:

- All elements must be of the same type, preferably integer, real, or complex numbers, for efficient numerical computing and storage.
- The number of elements must be known⁵ when the array is created.
- Arrays are not part of standard Python⁶ – one needs an additional package called *Numerical Python*, often abbreviated as NumPy. The Python name of the package, to be used in `import` statements, is `numpy`.
- With `numpy`, a wide range of mathematical operations can be done directly on complete arrays, thereby removing the need for loops over array elements. This is commonly called *vectorization* and may cause a dramatic speed-up of Python programs. Vectorization makes use of the vector computing concepts from Chapter 5.1.3.
- Arrays with one index are often called vectors. Arrays with two indices are used as an efficient data structure for tables, instead of lists of lists. Arrays can also have three or more indices.

The following text lists some important functionality of NumPy arrays. A more comprehensive treatment is found in the excellent *NumPy Tutorial*, *NumPy User Guide*, *NumPy Reference*, *Guide to NumPy*, and *NumPy for Matlab Users*, all found at scipy.org.

The standard import statement for Numerical Python reads

```
import numpy as np
```

To convert a list `r` to an array, we use the `array` function from `numpy`:

```
a = np.array(r)
```

To create a new array of length `n`, filled with zeros, we write

```
a = np.zeros(n)
```

⁵ The number of elements can be changed, at a substantial computational cost.

⁶ Actually, there is an object type called `array` in standard Python, but this data type is not so efficient for mathematical computations.

The array elements are of a type that corresponds to Python's `float` type. A second argument to `np.zeros` can be used to specify other element types, e.g., `int`. A similar function,

```
a = np.zeros_like(c)
```

generates an array of zeros where the length is that of the array `c` and the element type is the same as those in `c`. Arrays with more than one index are treated in Chapter 5.7.

Often one wants an array to have n elements with uniformly distributed values in an interval $[p, q]$. The numpy function `linspace` creates such arrays:

```
a = np.linspace(p, q, n)
```

Array elements are accessed by square brackets as for lists: `a[i]`. Slices also work as for lists, for example, `a[1:-1]` picks out all elements except the first and the last, but contrary to lists, `a[1:-1]` is not a copy of the data in `a`. Hence,

```
b = a[1:-1]
b[2] = 0.1
```

will also change `a[3]` to 0.1. A slice `a[i:j:s]` picks out the elements starting with index `i` and stepping `s` indices at the time up to, but not including, `j`. Omitting `i` implies `i=0`, and omitting `j` implies `j=n` if `n` is the number of elements in the array. For example, `a[0:-1:2]` picks out every two elements up to, but not including, the last element, while `a[:,4]` picks out every four elements in the whole array.

5.2.3 Computing Coordinates and Function Values

With these basic operations at hand, we can continue the session from the previous section and make arrays out of the lists `xlist` and `ylist`:

```
>>> import numpy as np
>>> x2 = np.array(xlist)      # turn list xlist into array x2
>>> y2 = np.array(ylist)
>>> x2
array([ 0.   ,  0.25,  0.5  ,  0.75,  1.   ])
>>> y2
array([ 0.         ,  0.015625,  0.125   ,  0.421875,  1.         ])
```

Instead of first making a list and then converting the list to an array, we can compute the arrays directly. The equally spaced coordinates in `x2` are naturally computed by the `np.linspace` function. The `y2` array can be created by `np.zeros`, to ensure that `y2` has the right length⁷

⁷ This is referred to as *allocating* the array, and means that a part of the computer's memory is marked for being occupied by this array.

`len(x2)`, and then we can run a `for` loop to fill in all elements in `y2` with `f` values:

```
>>> n = len(xlist)
>>> x2 = np.linspace(0, 1, n)
>>> y2 = np.zeros(n)
>>> for i in xrange(n):
...     y2[i] = f(x2[i])
...
>>> y2
array([ 0.          ,  0.015625,  0.125      ,  0.421875,  1.          ])
```

Note that we here in the `for` loop have used `xrange` instead of `range`. The former is faster for long loops because it avoids generating *and storing* a list of integers, it just generates the values one by one. Hence, we prefer `xrange` over `range` for loops over long arrays. In Python version 3.x, `range` is the same as `xrange`.

We can shorten the previous code by creating the `y2` data in a list comprehension, but list comprehensions produce lists, not arrays, so we need to transform the list object to an array object:

```
>>> x2 = np.linspace(0, 1, n)
>>> y2 = np.array([f(xi) for xi in x2])
```

Nevertheless, there is a faster way of computing `y2` as the next paragraph explains.

5.2.4 Vectorization

Loops over very long arrays may run slowly. A great advantage with arrays is that we can get rid of the loops and apply `f` directly to the whole array:

```
>>> y2 = f(x2)
>>> y2
array([ 0.          ,  0.015625,  0.125      ,  0.421875,  1.          ])
```

The magic that makes `f(x2)` work builds on the vector computing concepts from Chapter 5.1.3. Instead of calling `f(x2)` we can equivalently write the function formula `x2**3` directly.

The point is that `numpy` implements vector arithmetics *for arrays* of any dimension. Moreover, `numpy` provides its own versions of mathematical functions like `cos`, `sin`, `exp`, `log`, etc., which work for array arguments and apply the mathematical function to each element. The following code, computes each array element separately:

```
from math import sin, cos, exp
import numpy as np
r = np.zeros(len(x))
for i in xrange(len(x)):
    r[i] = sin(x[i])*cos(x[i])*exp(-x[i]**2) + 2 + x[i]**2
```

while here is a corresponding code which operate on arrays directly:

```
r = np.sin(x)*np.cos(x)*np.exp(-x**2) + 2 + x**2
```

Many will prefer to see such formulas without the `np` prefix:

```
from numpy import sin, cos, exp
r = sin(x)*cos(x)*exp(-x**2) + 2 + x**2
```

An important thing to understand is that `sin` from the `math` module is different from the `sin` function provided by `numpy`. The former does not allow array arguments, while the latter accepts both real numbers and arrays.

Replacing a loop like the one above, for computing `r[i]`, by a vector/array expression like `sin(x)*cos(x)*exp(-x**2) + 2 + x**2`, is called *vectorization*. The loop version is often referred to as *scalar code*. For example,

```
import numpy as np
import math
x = np.zeros(N); y = np.zeros(N)
dx = 2.0/(N-1) # spacing of x coordinates
for i in range(N):
    x[i] = -1 + dx*i
    y[i] = math.exp(-x[i])*x[i]
```

is scalar code, while the corresponding vectorized version reads

```
x = np.linspace(-1, 1, N)
y = np.exp(-x)*x
```

We remark that list comprehensions,

```
x = array([-1 + dx*i for i in range(N)])
y = array([np.exp(-xi)*xi for xi in x])
```

result in scalar code because we still have explicit, slow Python `for` loops operating on scalar quantities. The requirement of vectorized code is that there are no explicit Python `for` loops. The loops required to compute each array element are performed in fast C or Fortran code in the `numpy` package.

Most Python functions intended for a scalar argument `x`, like

```
def f(x):
    return x**4*exp(-x)
```

automatically work for an array argument `x`:

```
x = np.linspace(-3, 3, 101)
y = f(x)
```

provided that the `exp` function in the definition of `f` accepts an array argument. This means that `exp` must have been imported as `from numpy`

`import *` or explicitly as `from numpy import exp`. One can, of course, prefix `exp` as in `np.exp`, at the loss of a less attractive mathematical syntax in the formula.

When a Python function $f(x)$ works for an array argument x , we say that the function f is vectorized. Provided that the mathematical expressions in f involves arithmetic operations and basic mathematical functions from the `math` module, f will be automatically vectorized by just importing the functions from `numpy` instead of `math`. However, if the expression inside f involves `if` tests, the code needs a rewrite to work with arrays. Chapter 5.4.1 presents examples where we have to do special actions in order to vectorize functions.

Vectorization is very important for speeding up Python programs that perform heavy computations with arrays. Moreover, vectorization gives more compact code that is easier to read. Vectorization becomes particularly important for statistical simulations in Chapter 8.

5.3 Curve Plotting

Visualizing a function $f(x)$ is done by drawing the curve $y = f(x)$ in an xy coordinate system. When we use a computer to do this task, we say that we *plot* the curve. Technically, we plot a curve by drawing straight lines between n points on the curve. The more points we use, the smoother the curve appears.

Suppose we want to plot the function $f(x)$ for $a \leq x \leq b$. First we pick out n x coordinates in the interval $[a, b]$, say we name these x_0, x_1, \dots, x_{n-1} . Then we evaluate $y_i = f(x_i)$ for $i = 0, 1, \dots, n-1$. The points (x_i, y_i) , $i = 0, 1, \dots, n-1$, now lie on the curve $y = f(x)$. Normally, we choose the x_i coordinates to be equally spaced, i.e.,

$$x_i = a + ih, \quad h = \frac{b-a}{n-1}.$$

If we store the x_i and y_i values in two arrays `x` and `y`, we can plot the curve by the command like `plot(x,y)`.

Sometimes the names of the independent variable and the function differ from x and f , but the plotting procedure is the same. Our first example of curve plotting demonstrates this fact by involving a function of t .

5.3.1 Matplotlib; Pylab

The standard package for curve plotting in Python is Matplotlib. First we exemplify Matplotlib using `matplotlib.pylab`, which enables a syntax very close to that of Matlab. This is a great advantage since many

readers may have experience with plotting in Matlab, or they will certainly meet Matlab sometime in their scientific work.

A Basic Plot. Let us plot the curve $y = t^2 \exp(-t^2)$ for t values between 0 and 3. First we generate equally spaced coordinates for t , say 51 values (50 intervals). Then we compute the corresponding y values at these points, before we call the `plot(t,y)` command to make the curve plot. Here is the complete program:

```
from matplotlib.pyplot import *

def f(t):
    return t**2*exp(-t**2)

t = linspace(0, 3, 51)    # 51 points between 0 and 3
y = zeros(len(t))        # allocate y with float elements
for i in xrange(len(t)):
    y[i] = f(t[i])

plot(t, y)
show()
```

The `from matplotlib.pyplot import *` performs a `from numpy import *` import as well as an import of all Matplotlib commands that resemble Matlab-style syntax. In this program we pre-allocate the `y` array and fill it with values, element by element, in a Python loop. Alternatively, we may operate on the whole `t` array at once, which yields faster and shorter code:

```
y = f(t)
```

To include the plot in electronic documents, we need a hardcopy of the figure in PostScript, PNG, or another image format. The `savefig` function saves the plot to files in various image formats:

```
savefig('tmp1.eps') # produce PostScript
savefig('tmp1.png') # produce PNG
```

The filename extension determines the format: `.eps` for PostScript and `.png` for PNG. Figure 5.2 displays the resulting plot.

Decorating the Plot. The x and y axes in curve plots should have labels, here t and y , respectively. Also, the curve should be identified with a label, or legend as it is often called. A title above the plot is also common. In addition, we may want to control the extent of the axes (although most plotting programs will automatically adjust the axes to the range of the data). All such things are easily added after the `plot` command:

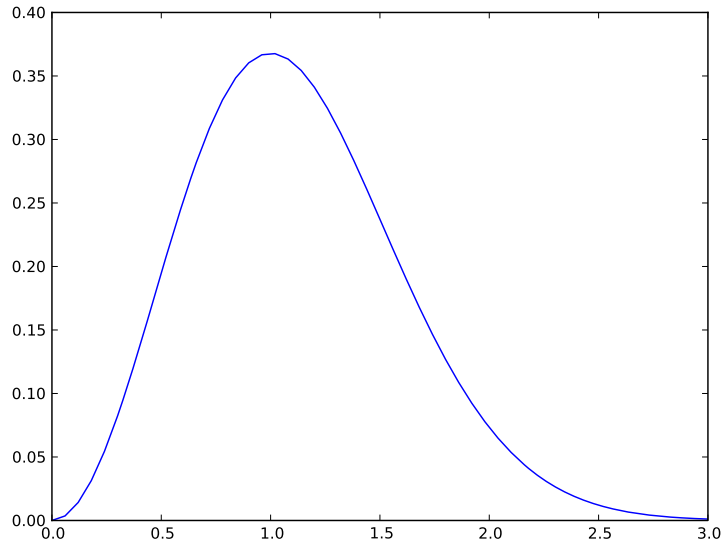

Fig. 5.2 A simple plot in PostScript format (Matplotlib).

```

plot(t, y)
xlabel('t')
ylabel('y')
legend(['t^2*exp(-t^2)'])
axis([0, 3, -0.05, 0.6]) # [tmin, tmax, ymin, ymax]
title('My First Matplotlib Demo')
savefig('tmp2.eps')
show()

```

Removing the `show()` call prevents the plot from being shown on the screen, which is advantageous if the program's purpose is to make a large number of plots in PostScript or PNG format (you do not want all the plot windows to appear on the screen and then kill all of them manually). This decorated plot is displayed in Figure 5.3.

Plotting Multiple Curves. A common plotting task is to compare two or more curves, which requires multiple curves to be drawn in the same plot. Suppose we want to plot the two functions $f_1(t) = t^2 \exp(-t^2)$ and $f_2(t) = t^4 \exp(-t^2)$. We can then just issue two `plot` commands, one for each function. To make the syntax resemble Matlab, we call `hold('on')` after the first `plot` command to indicate that subsequent `plot` commands are to draw the curves in the first plot.

```

def f1(t):
    return t**2*exp(-t**2)

def f2(t):
    return t**2*f1(t)

t = linspace(0, 3, 51)
y1 = f1(t)

```

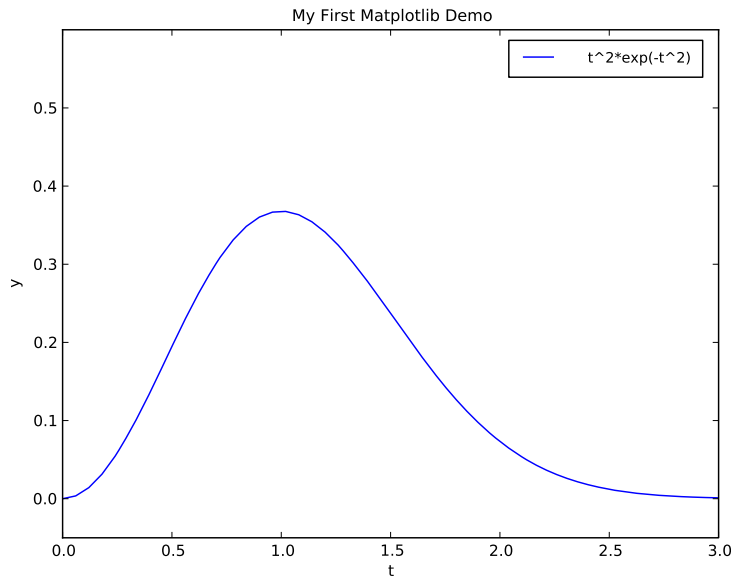

Fig. 5.3 A single curve with label, title, and axis adjusted (Matplotlib).

```

y2 = f2(t)

plot(t, y1, 'r-')
hold('on')
plot(t, y2, 'bo')
xlabel('t')
ylabel('y')
legend(['t^2*exp(-t^2)', 't^4*exp(-t^2)'])
title('Plotting two curves in the same plot')
show()

```

In these `plot` commands, we have also specified the line type: `r-` means red (`r`) line (`-`), while `bo` means a blue (`b`) circle (`o`) at each data point. Figure 5.4 shows the result. The legends for each curve is specified in a list where the sequence of strings correspond to the sequence of `plot` commands. Doing a `hold('off')` makes the next `plot` command create a new plot.

Placing Several Plots in One Figure. We may also put plots together in a figure with `r` rows and `c` columns of plots. The `subplot(r,c,a)` does this, where `a` is a row-wise counter for the individual plots. Here is an example with two rows of plots, and one plot in each row (see Figure 5.5):

```

figure() # make separate figure
subplot(2, 1, 1)
t = linspace(0, 3, 51)
y1 = f1(t)
y2 = f2(t)

plot(t, y1, 'r-', t, y2, 'bo')
xlabel('t')

```

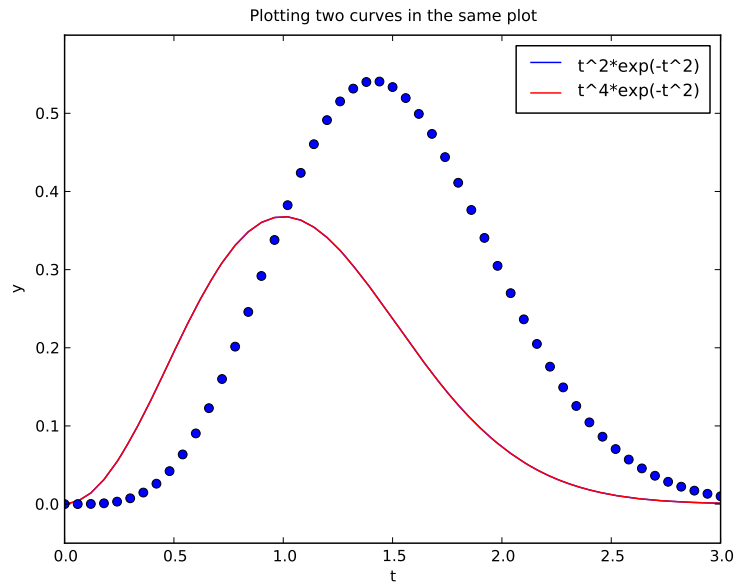

Fig. 5.4 Two curves in the same plot (Matplotlib).

```

ylabel('y')
axis([t[0], t[-1], min(y2)-0.05, max(y2)+0.5])
legend(['t^2*exp(-t^2)', 't^4*exp(-t^2)'])
title('Top figure')

subplot(2, 1, 2)
t3 = t[:4]
y3 = f2(t3)

plot(t, y1, 'b-', t3, y3, 'ys')
xlabel('t')
ylabel('y')
axis([0, 4, -0.2, 0.6])
legend(['t^2*exp(-t^2)', 't^4*exp(-t^2)'])
title('Bottom figure')
savefig('tmp4.eps')
show()

```

The `figure()` call creates a new plot window on the screen.

All of the examples above on plotting with Matplotlib are collected in the file `mpl_pylab_examples.py`.

5.3.2 Matplotlib; Pyplot

The Matplotlib developers do not promote the `matplotlib.pylab` interface. Instead, they recommend the `matplotlib.pyplot` module and prefix Numerical Python and Matplotlib functionality by short forms of their package names:

```

import numpy as np
import matplotlib.pyplot as plt

```

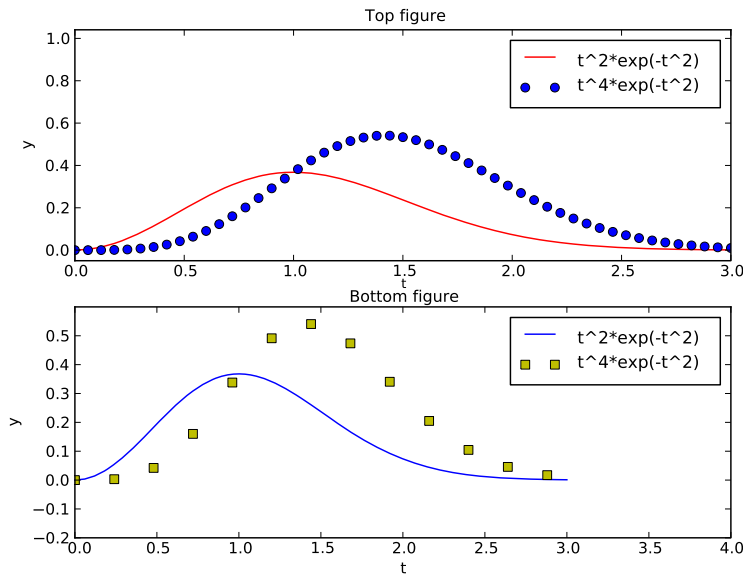

Fig. 5.5 Example on two plots in one figure (Matplotlib).

The commands in `matplotlib.pyplot` are similar to those in `matplotlib.pylab`. The plot in Figure 5.3 can typically be obtained by prefixing the `pylab` commands with `plt`:

```
plt.plot(t, y)
plt.legend(['t^2*exp(-t^2)'])
plt.xlabel('t')
plt.ylabel('y')
plt.axis([0, 3, -0.05, 0.6]) # [tmin, tmax, ymin, ymax]
plt.title('My First Matplotlib Demo')
plt.show()
plt.savefig('tmp2.eps') # produce PostScript
```

Instead of giving plot data and legends separately, it is more common to write

```
plt.plot(t, y, label='t^2*exp(-t^2)')
```

However, in this book we shall stick to the `legend` command since this makes the transition to/from Matlab easier.

Figure 5.4 can be produced by

```
def f1(t):
    return t**2*np.exp(-t**2)

def f2(t):
    return t**2*f1(t)

t = np.linspace(0, 3, 51)
y1 = f1(t)
y2 = f2(t)

plt.plot(t, y1, 'r-')
plt.plot(t, y2, 'bo')
```

```
plt.xlabel('t')
plt.ylabel('y')
plt.legend(['t^2*exp(-t^2)', 't^4*exp(-t^2)'])
plt.title('Plotting two curves in the same plot')
plt.savefig('tmp3.eps')
plt.show()
```

Putting multiple plots in a figure follows the same set-up with `subplot` as shown for `pylab`, except that commands are prefixed by `plt`. The complete example, along with the codes listed above, are found in the file `mpl_pyplot_examples.py`.

Once you have created a basic plot, there are numerous possibilities for fine-tuning the figure, i.e., adjusting tick marks on the axis, inserting text, etc. The Matplotlib website is full of instructive examples on what you can do with this excellent package.

5.3.3 SciTools and Easyviz

Although Matplotlib has recently evolved to be the *de facto* standard for curve plotting in Python, there are several other alternative packages, especially if we also consider plotting of 2D/3D scalar and vector fields. Python has interfaces to many leading visualization packages: Matlab, Gnuplot, Grace, OpenDX, and VTK. Even basic plotting with these packages has very different syntax, and deciding which package and syntax to go with was and still is a challenge. As a response to this challenge, Easyviz was created to provide a common uniform interface to all the mentioned visualization packages (including Matplotlib). The syntax of this interface was made very close to that of Matlab, since most scientists and engineers have experience with Matlab or most probably will be using it in some context⁸.

Easyviz is part of the SciTools package, which consists of a set of Python tools building on Numerical Python, ScientificPython, the comprehensive SciPy environment, and other packages for scientific computing with Python. SciTools contains in particular software related to the book [5] and the present text. Installation is straightforward (just run `python setup.py install`, if you have downloaded the source code, or do `sudo apt-get install python-scitools` on Debian-based systems such as Ubuntu Linux).

Importing SciTools and Easyviz. A standard import of SciTools is

```
from scitools.std import *
```

⁸ In general, the Python syntax used in the examples in this book is constructed to ease the transition to and from Matlab.

The advantage of this statement is that it, with a minimum of typing, imports a lot of useful modules for numerical Python programming: Easyviz, all of `numpy` (from `numpy import *`), all of `scipy` (from `scipy import *`) if available, all of `scitools.numpyutils` (some convenience functions extending `numpy`), `numpy.lib.scimath` (see Chapter 1.6.3), `StringFunction` tool (see Chapter 4.1.4), plus commonly applied modules such as `sys`, `os`, and `math`. The imported standard mathematical functions (`sqrt`, `sin`, `asin`, `exp`, etc.) work with arrays and deal transparently with real and complex input/output (as the corresponding Matlab functions).

The downside of the “star import” from `scitools.std` is twofold. First, it fills up your program or interactive session with the names of several hundred functions. Second, when using a particular function, you do not know the package it comes from. Both problems are solved by doing an import of the type used in Chapter 5.3.2:

```
import scitools.std as st
import numpy as np
```

All of the SciTools and Easyviz functions must then be prefixed by `st`. Although the `numpy` functions are available through the `st` prefix, we recommend to use the `np` prefix to clearly see where functionality comes from.

Importing `scitools.std` might be a comprehensive process, especially if `scipy` is available, and consequently take some time. A more minimalistic and faster import for plotting with Easyviz is

```
from scitools.easyviz import *
from numpy import *
```

or

```
import scitools.easyviz as ev
import numpy as np
```

The Easyviz plotting functions must then be prefixed by `ev`.

Since the Easyviz syntax for plotting is very close to that of Matlab, it is also very close to the syntax of Matplotlib. This will be demonstrated in the forthcoming examples. The advantage of using Easyviz is that the underlying plotting package, used to create the graphics and known as a *backend*, can trivially be replaced by another package. If users of your Python software have not installed a particular visualization package, the software can still be used with another alternative (which might be considerably easier to install). By default, Easyviz now employs Matplotlib for plotting. Other popular alternatives are Gnuplot and Matlab. For 2D/3D scalar and vector fields, VTK is a popular backend for Easyviz.

We shall next redo the curve plotting examples from Chapter 5.3.1 using Easyviz syntax.

A Basic Plot. Plotting the curve $y = t^2 \exp(-t^2)$ for $t \in [0, 3]$, using 51 equally spaced points (50 intervals) is performed by like this:

```
from scitools.std import *

def f(t):
    return t**2*exp(-t**2)

t = linspace(0, 3, 51)
y = f(t)
plot(t, y)
```

To save the plot in a file, either in PostScript or PNG format, we use the `savefig` function, which takes the filename as argument:

```
savefig('tmp1.eps') # produce PostScript
savefig('tmp1.png') # produce PNG
```

The filename extension determines the format: `.ps` or `.eps` for PostScript, and `.png` for PNG. A synonym for the `savefig` function is `hardcopy`.

On some platforms, some backends may result in a plot that is shown in just a fraction of a second on the screen before the plot window disappears (using the Gnuplot backend on Windows machines, or using the Matplotlib backend, constitute two examples). To make the window stay on the screen, add

```
raw_input('Press the Return key to quit: ')
```

at the end of the program. The plot window is killed when the program terminates, and this statement postpones the termination until the user hits the Return key.

Decorating the Plot. Let us plot the same curve, but now with a legend, a plot title, labels on the axes, and specified ranges of the axes:

```
from scitools.std import *

def f(t):
    return t**2*exp(-t**2)

t = linspace(0, 3, 51)
y = f(t)
plot(t, y)
xlabel('t')
ylabel('y')
legend('t^2*exp(-t^2)')
axis([0, 3, -0.05, 0.6]) # [tmin, tmax, ymin, ymax]
title('My First Easyviz Demo')
```

Easyviz has also introduced a more “Pythonic” `plot` command where all the plot properties can be set at once through keyword arguments:

```

plot(t, y,
     xlabel='t',
     ylabel='y',
     legend='t^2*exp(-t^2)',
     axis=[0, 3, -0.05, 0.6],
     title='My First Easyviz Demo',
     savefig='tmp1.eps',
     show=True)

```

With `show=False` one can avoid the plot window on the screen and just make the plot file.

Note that we in the curve legend write t square as `t^2` (L^AT_EX style) rather than `t**2` (program style). Whichever form you choose is up to you, but the L^AT_EX form sometimes looks better in some plotting programs (Matplotlib and Gnuplot are two examples).

Plotting Multiple Curves. Next we want to compare the two functions $f_1(t) = t^2 \exp(-t^2)$ and $f_2(t) = t^4 \exp(-t^2)$. Writing two `plot` commands after each other makes two separate plots. To make the second curve appear together with the first one, we need to issue a `hold('on')` call after the first `plot` command. All subsequent `plot` commands will then draw curves in the same plot, until `hold('off')` is called.

```

from scitools.std import *

def f1(t):
    return t**2*exp(-t**2)

def f2(t):
    return t**2*f1(t)

t = linspace(0, 3, 51)
y1 = f1(t)
y2 = f2(t)

plot(t, y1)
hold('on')
plot(t, y2)

xlabel('t')
ylabel('y')
legend('t^2*exp(-t^2)', 't^4*exp(-t^2)')
title('Plotting two curves in the same plot')
savefig('tmp3.eps')

```

The sequence of the multiple legends is such that the first legend corresponds to the first curve, the second legend to the second curve, and so forth.

Instead of separate calls to `plot` and the use of `hold('on')`, we can do everything at once and just send several curves to `plot`:

```

plot(t, y1, t, y2, xlabel='t', ylabel='y',
     legend=('t^2*exp(-t^2)', 't^4*exp(-t^2)'),
     title='Plotting two curves in the same plot',
     savefig='tmp3.eps')

```

Throughout this book, we very often make use of this type of compact plot command, which also only requires an import of the form `from scitools.std import plot`.

Changing Backend. Easyviz applies Matplotlib for plotting by default, so the resulting figures so far will be similar to those of Figure 5.2–5.4.

However, we can use other backends (plotting packages) for creating the graphics. The specification of which package to use is defined in a configuration file⁹, or on the command line:

Terminal

```
Terminal> python myprog.py --SCITTOOLS_easyviz_backend gnuplot
```

Now, the plotting commands in `myprog.py` will make use of Gnuplot to create the graphics, with a slightly different result than that created by Matplotlib (compare Figures 5.4 and 5.6).

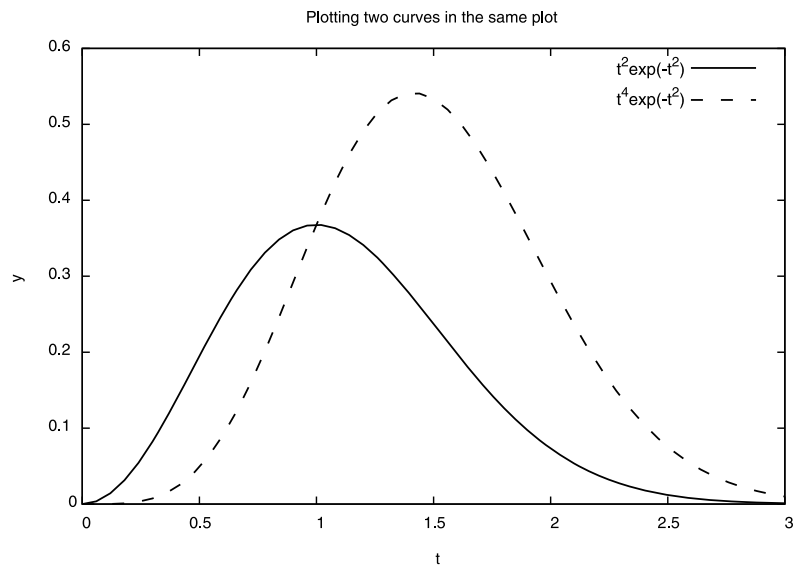

Fig. 5.6 Two curves in the same plot (Gnuplot).

Placing Several Plots in One Figure. Finally, we redo the example from Chapter 5.3.1 where two plots are combined into one figure, using the `subplot` command:

```
figure()
subplot(2, 1, 1)
t = linspace(0, 3, 51)
y1 = f1(t)
y2 = f2(t)
```

⁹ See the heading “Setting Parameters in the Configuration File” in the Easyviz documentation.

```

plot(t, y1, 'r-', t, y2, 'bo', xlabel='t', ylabel='y',
     legend=('t^2*exp(-t^2)', 't^4*exp(-t^2)'),
     axis=[t[0], t[-1], min(y2)-0.05, max(y2)+0.5],
     title='Top figure')

subplot(2, 1, 2)
t3 = t[:4]
y3 = f2(t3)

plot(t, y1, 'b-', t3, y3, 'ys',
     xlabel='t', ylabel='y',
     axis=[0, 4, -0.2, 0.6],
     legend=('t^2*exp(-t^2)', 't^4*exp(-t^2)'),
     title='Bottom figure')
savefig('tmp4.eps')

```

Note that `figure()` must be used if you want a program to make different plot windows on the screen: each `figure()` call creates a new, separate plot.

All of the Easyviz examples above are found in the file `easyviz_examples.py`. We remark that Easyviz is just a thin layer of code providing access to the most common plotting functionality for curves as well as 2D/3D scalar and vector fields. Fine-tuning of plots, e.g., specifying tick marks on the axes, is not supported, simply because 99% of plots in the daily work can be made without such functionality. For fine-tuning the plot with special commands, you need to grab an object in Easyviz that communicates directly with the underlying plotting package used to create the graphics. With this object you can issue package-specific commands and do whatever the underlying package allows you do. This is explained in the [Easyviz manual](#), which you can find at code.google.com/p/scitools. You can also get a plain text version of the manual by running `pydoc scitools.easyviz`. As soon as you have digested the very basics of plotting, you are strongly recommend to read through the curve plotting part of the Easyviz manual.

5.3.4 Making Animations

A sequence of plots can be combined into an animation and stored in a movie file. First we must generate a series of hardcopies, i.e., plots stored in files. Thereafter we must use a tool to combine the individual plot files into a movie file.

Example. The function

$$f(x; m, s) = (2\pi)^{-1/2} s^{-1} \exp\left[-\frac{1}{2}\left(\frac{x-m}{s}\right)^2\right]$$

is known as the Gaussian function or the probability density function of the normal (or Gaussian) distribution. This bell-shaped function is

“wide” for large s and “peak-formed” for small s , see Figure 5.7. The function is symmetric around $x = m$ ($m = 0$ in the figure). Our goal is to make an animation where we see how this function evolves as s is decreased. In Python we implement the formula above as a function $f(x, m, s)$.

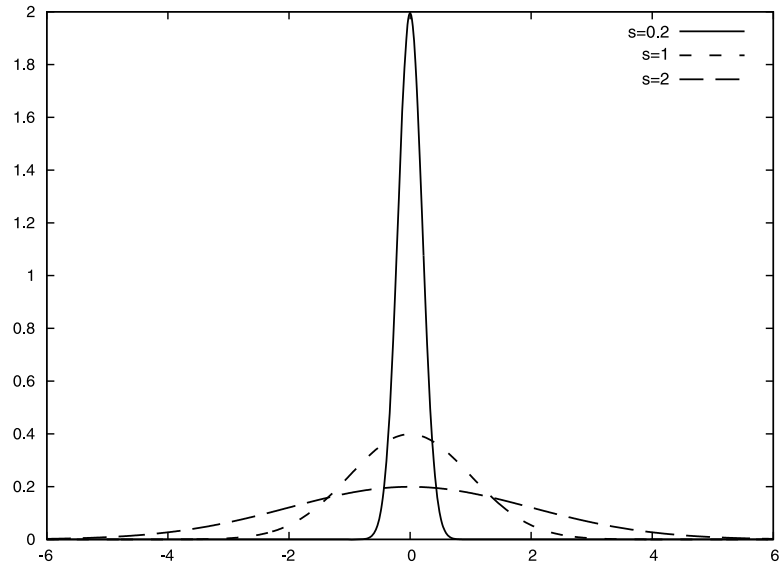

Fig. 5.7 Different shapes of a Gaussian function.

The animation is created by varying s in a loop and for each s issue a `plot` command. A moving curve is then visible on the screen. One can also make a movie file that can be played as any other computer movie using a standard movie player. To this end, each plot is saved to a file, and all the files are combined together using some suitable tool, which is reached through the `movie` function in Easyviz. All necessary steps will be apparent in the complete program below, but before diving into the code we need to comment upon a couple of issues with setting up the `plot` command for animations.

The underlying plotting program will normally adjust the axis to the maximum and minimum values of the curve if we do not specify the axis ranges explicitly. For an animation such automatic axis adjustment is misleading – any axis range must be fixed to avoid a jumping axis. The relevant values for the y axis range is the minimum and maximum value of f . The minimum value is zero, while the maximum value appears for $x = m$ and increases with decreasing s . The range of the y axis must therefore be $[0, f(m; m, \min s)]$.

The function f is defined for all $-\infty < x < \infty$, but the function value is very small already $3s$ away from $x = m$. We may therefore limit the x coordinates to $[m - 3s, m + 3s]$.

Now we are ready to take a look at the complete code for animating how the Gaussian function evolves as the s parameter is decreased from 2 to 0.2. First we show animation with the help of Easyviz, as this is very similar standard static plotting, and you can choose which plotting engine you want to use, say Gunplot or Matplotlib. The Easyviz recipe goes as follows.

```

from scitools.std import sqrt, pi, exp, linspace, plot, movie
import time

def f(x, m, s):
    return (1.0/(sqrt(2*pi)*s))*exp(-0.5*((x-m)/s)**2)

m = 0
s_min = 0.2
s_max = 2
x = linspace(m -3*s_max, m + 3*s_max, 1000)
s_values = linspace(s_max, s_min, 30)
# f is max for x=m; smaller s gives larger max value
max_f = f(m, m, s_min)

# Show the movie on the screen
# and make hardcopies of frames simultaneously.

counter = 0
for s in s_values:
    y = f(x, m, s)
    plot(x, y, axis=[x[0], x[-1], -0.1, max_f],
         xlabel='x', ylabel='f', legend='s=%4.2f' % s,
         savefig='tmp%04d.png' % counter)
    counter += 1
    #time.sleep(0.2) # can insert a pause to control movie speed

# Make movie file the simplest possible way:
movie('tmp*.png')

```

Note that the s values are decreasing (`linspace` handles this automatically if the start value is greater than the stop value). Also note that we, simply because we think it is visually more attractive, let the y axis go from -0.1 although the f function is always greater than zero. The complete code is found in the file `movie1.py`.

It is crucial to use the single, compound `plot` command shown above, where axis, labels, legends, etc., are set in the same call. Splitting up in individual calls to `plot`, `axis`, and so forth, results in jumping curves and axis. Also, when visualizing more than one animated curve at a time, make sure you send all data to a single `plot` command.

Animation in Matplotlib. Moving curves in Matplotlib require constructions that differ from the Easyviz recipe given above. The first part of the program is the same where we define `f`, `x`, `s_values`, and so on. Here we concentrate on the graphics part:

```

import matplotlib.pyplot as mpl
...
# Make a first plot
mpl.ion()
y = f(x, m, s_max)

```

```

lines = mpl.plot(x, y)
mpl.axis([x[0], x[-1], -0.1, max_f])
mpl.xlabel('x')
mpl.ylabel('f')

# Show the movie, and make hardcopies of frames simultaneously
counter = 0
for s in s_values:
    y = f(x, m, s)
    lines[0].set_ydata(y)
    mpl.draw()
    mpl.legend(['s=%4.2f' % s])
    mpl.savefig('tmp_%04d.png' % counter)
    counter += 1

```

The `mpl.ion()` call is important, so is the first plot, where we grab the result of the `plot` command, which is a list of Matplotlib's `Line2D` objects. The idea is then to update the data via `lines[0].set_ydata` and show the plot via `mpl.draw()` for each frame. For multiple curves we must update the y data for each curve, e.g.,

```

lines = plot(x, y1, x, y2, x, y3)

for parameter in parameters:
    y1 = ...
    y2 = ...
    y3 = ...
    for line, y in zip(lines, [y1, y2, y3]):
        line.set_ydata(y)
    mpl.draw()

```

The file `movie1_mpl.py` has a complete program doing animation with native Matplotlib syntax.

Remarks on Filenames. For each frame (plot) in the movie we store the plot in a file. The different files need different names and an easy way of referring to the set of files in right order. We therefore suggest to use filenames of the form `tmp0001.png`, `tmp0002.png`, `tmp0003.png`, etc. The `printf` format `04d` pads the integers with zeros such that 1 becomes 0001, 13 becomes 0013 and so on. The expression `tmp*.png` will now expand (by an alphabetic sort) to a list of all files in proper order. Without the padding with zeros, i.e., names of the form `tmp1.png`, `tmp2.png`, ..., `tmp12.png`, etc., the alphabetic order will give a wrong sequence of frames in the movie. For instance, `tmp12.png` will appear before `tmp2.png`.

Note that the names of plot files specified when making hardcopies must be consistent with the specification of names in the call to the Easyviz `movie` function. Typically, one applies a Unix wildcard notation in the call to `movie`, say `plotfile*.eps`, where the asterisk will match any set of characters. When specifying hardcopies, we must then use a filename that is consistent with `plotfile*.eps`, that is, the filename must start with `plotfile` and end with `.eps`, but in between these two parts we are free to construct (e.g.) a frame number padded with zeros.

We recommend to always remove previously generated plot files before a new set of files is made. Otherwise, the movie may get old and new files mixed up. The following Python code removes all files of the form `tmp*.png`:

```
import glob, os
for filename in glob.glob('tmp*.png'):
    os.remove(filename)
```

These code lines should be inserted at the beginning of the code example above. Alternatively, one may store all plotfiles in a subfolder and later delete the subfolder. Here is a suitable code segment¹⁰:

```
import shutil, os
subdir = 'temp' # subfolder name for plot files
if os.path.isdir(subdir): # does the subfolder already exist?
    shutil.rmtree(subdir) # delete the whole folder
os.mkdir(subdir) # make new subfolder
os.chdir(subdir) # move to subfolder
# ... perform all the plotting, make movie ...
os.chdir(os.pardir) # optional: move up to parent folder
```

Movie Formats. Having a set of (e.g.) `tmp*.png` files, one can simply generate a movie by a `movie('tmp*.png')` call. The `movie` function generates a movie file called `movie.html` (HTML format), `movie.avi` (AVI format), `movie.mpeg` (MPEG format), or `movie.gif` (animated GIF format) in the current working directory. The movie format depends on the encoders found on your machine. The HTML format can always be made and played. Hence this format is the natural choice if problems with other formats occur. The corresponding `movie` call reads

```
movie('tmp*.png', encoder='html', output_file='tmpmovie.html')
```

You can get complete control of the movie format and the name of the movie file by supplying extra arguments to the `movie` function. First, let us generate an animated GIF file called `tmpmovie.gif`:

```
movie('tmp*.eps', encoder='convert', fps=2,
      output_file='tmpmovie.gif')
```

The generation of animated GIF images applies the `convert` program from the ImageMagick suite. This program must of course be installed on the machine. The argument `fps` stands for frames per second so here the speed of the movie is slow in that there is a delay of half a second between each frame (image file). The complete `convert` command that is run by `movie` is also printed on the screen. In this case it looks like

```
convert -delay 50 tmp*.png tmpmovie.gif
```

which is a command you can run manually instead of calling `movie`. To view the animated GIF file, one can use the `animate` program (also

¹⁰ Python and many other languages use the word `directory` instead of `folder`. Consequently, the name of functions dealing with folders have a name with `dir` for “directory”.

from ImageMagick) and give the movie file as command-line argument. One can alternatively put the GIF file in a web page in an IMG tag such that a browser automatically displays the movie (see below).

An AVI movie can be generated by the call

```
movie('tmp_*.eps', encoder='ffmpeg', fps=4,
      output_file='tmpmovie1.avi',
```

Alternatively, we may generate an MPEG movie using the `ppmtompeg` encoder from the Netpbm suite of image manipulation tools:

```
movie('tmp_*.eps', encoder='ppmtompeg', fps=24,
      output_file='tmpmovie2.mpeg',
```

The `ppmtompeg` supports only a few (high) frame rates.

The next sample call to `movie` uses the `Mencoder` tool and specifies some additional arguments (video codec, video bitrate, and the quantization scale):

```
movie('tmp_*.eps', encoder='mencoder', fps=24,
      output_file='tmpmovie.mpeg',
      vcodec='mpeg2video', vbitrate=2400, qscale=4)
```

Note that even if you prefer to make the individual plot files by `Matplotlib`, `Matlab`, or whatever, the `movie` command from `Easyviz` is still handy to make a movie file out of the individual plot files. All you need to do is `from scitools.std import movie` and call `movie` with the right specification of plot file names.

Playing movie files can be done by a lot of programs. Windows Media Player is a default choice on Windows machines. On Unix, a variety of tools are available. For animated GIF files the `animate` program from the ImageMagick suite is suitable, or one can simply show the file in a web page with the HTML command ``. AVI and MPEG files can be played by, for example, the `mplayer`, `vlc`, or `totem` programs. The HTML movie is always trouble-free to play: just load `tmpmovie.html` into any web browser on any platform.

5.3.5 Curves in Pure Text

Sometimes it can be desirable to show a graph in pure ASCII text, e.g., as part of a trial run of a program included in the program itself (cf. the introduction to Chapter 1.8), or a graph can be illustrative in a doc string. For such purposes we have slightly extended a module by Imri Goldberg (`aplotter.py`) and included it as a module in `SciTools`. Running `pydoc on scitools.aplotter` describes the capabilities of this type of primitive plotting. Here we just give an example of what it can do:

```

>>> import numpy as np
>>> x = np.linspace(-2, 2, 81)
>>> y = np.exp(-0.5*x**2)*np.cos(np.pi*x)
>>> from scitools.aplotter import plot
>>> plot(x, y)

```

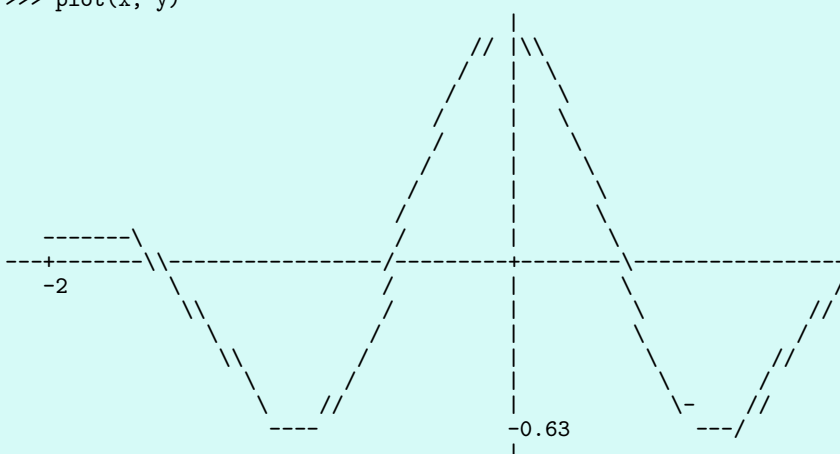

```

>>> # plot circles at data points only:
>>> plot(x, y, dot='o', plot_slope=False)

```

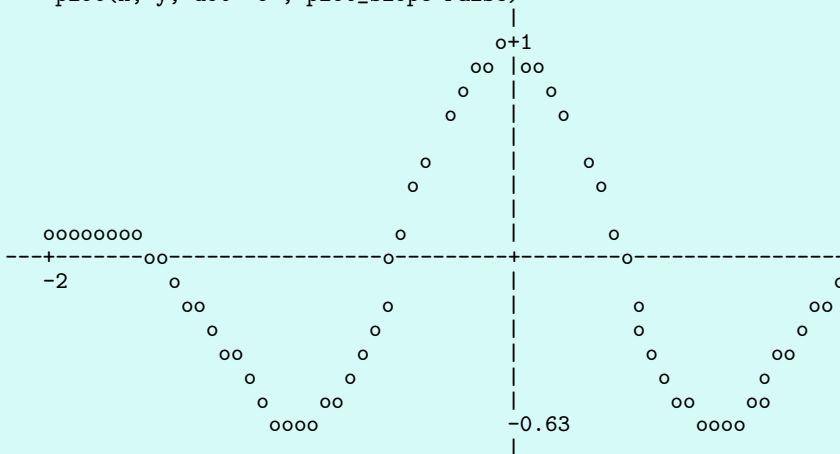

```

>>> p = plot(x, y, output=str) # store plot in a string p
>>> print p

```

(The last 13 characters of the output lines are here removed to make the lines fit the maximum textwidth of this book.)

5.4 Plotting Difficulties

The previous examples on plotting functions demonstrate how easy it is to make graphs. Nevertheless, the shown techniques might easily fail to plot some functions correctly unless we are careful. Next we address two types of difficult functions: piecewisely defined functions and rapidly varying functions.

5.4.1 Piecewisely Defined Functions

A piecewisely defined function has different function definitions in different intervals along the x axis. The resulting function, made up of pieces, may have discontinuities in the function value or in derivatives. We have to be very careful when plotting such functions, as the next two examples will show. The problem is that the plotting mechanism draws straight lines between coordinates on the function's curve, and these straight lines may not yield a satisfactory visualization of the function. The first example has a discontinuity in the function itself at one point, while the other example has a discontinuity in the derivative at three points.

Example: The Heaviside Function. Let us plot the Heaviside function

$$H(x) = \begin{cases} 0, & x < 0 \\ 1, & x \geq 0 \end{cases}$$

The most natural way to proceed is first to define the function as

```
def H(x):
    return (0 if x < 0 else 1)
```

The standard plotting procedure where we define a coordinate array x and call $y = H(x)$ will not work for array arguments x , of reasons to be explained in Chapter 5.5.2. However, we may use techniques from that chapter to create a function $Hv(x)$ which works for array arguments. Even with such a function we face difficulties with plotting it.

Since the Heaviside function consists of two flat lines, one may think that we do not need many points along the x axis to describe the curve. Let us try with nine points:

```
x = np.linspace(-10, 10, 9)
from scitools.std import plot
plot(x, Hv(x), axis=[x[0], x[-1], -0.1, 1.1])
```

However, so few x points are not able to describe the jump from 0 to 1 at $x = 0$, as shown by the solid line in Figure 5.8a. Using more points, say 50 between -10 and 10 ,

```
x2 = np.linspace(-10, 10, 50)
plot(x, Hv(x), 'r', x2, Hv(x2), 'b',
     legend=('5 points', '50 points'),
     axis=[x[0], x[-1], -0.1, 1.1])
```

makes the curve look better. However, the step is still not strictly vertical. More points will improve the situation. Nevertheless, the best is to draw two flat lines directly: from $(-10, 0)$ to $(0, 0)$, then to $(0, 1)$ and then to $(10, 1)$:

```
plot([-10, 0, 0, 10], [0, 0, 1, 1],
     axis=[x[0], x[-1], -0.1, 1.1])
```

The result is shown in Figure 5.8b.

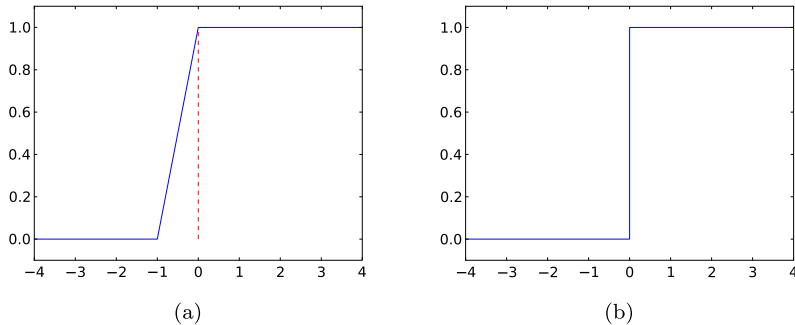

Fig. 5.8 Plot of the Heaviside function: (a) using 9 equally spaced x points; (b) using a “double point” at $x = 0$.

Some will argue that the plot of $H(x)$ should not contain the vertical line from $(0, 0)$ to $(0, 1)$, but only two horizontal lines. To make such a plot, we must draw two distinct curves, one for each horizontal line:

```
plot([-10,0], [0,0], 'r-', [0,10], [1,1], 'r-',
     axis=[x[0], x[-1], -0.1, 1.1])
```

Observe that we must specify the same line style for both lines (curves), otherwise they would by default get different colors on the screen or different line types in a hardcopy of the plot. We remark, however, that discontinuous functions like $H(x)$ are often visualized with vertical lines at the jumps, as we do in Figure 5.8b.

Example: A Hat Function. Let us plot the hat function $N(x)$, defined by (3.5) on page 105. The Python function `N(x)` shown right after (3.5) does not work with array arguments x , but Chapter 5.5.3 explains how to make a vectorized version `Nv(x)` which works for array arguments. Nevertheless, this vectorized version faces challenges when it comes to plotting.

A first approach to plotting could be

```
x = np.linspace(-2, 4, 6)
plot(x, Nv(x), 'r', axis=[x[0], x[-1], -0.1, 1.1])
```

This results in the dashed line in Figure 5.9. What is the problem? The problem lies in the computation of the x vector, which does not contain the points $x = 1$ and $x = 2$ where the function makes significant changes. The result is that the hat is “flattened”. Making an x vector with all critical points in the function definitions, $x = 0, 1, 2$, provides the necessary remedy, either

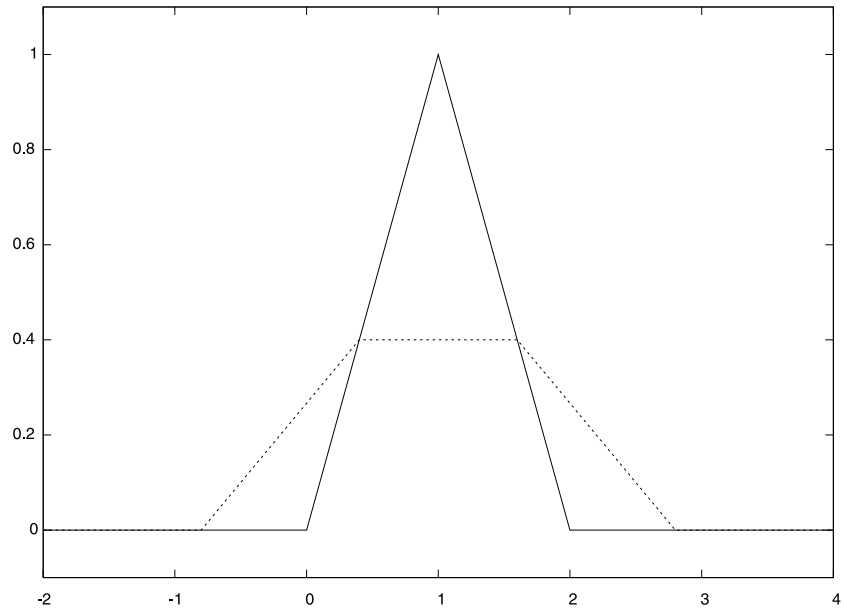

Fig. 5.9 Plot of a hat function. The solid line shows the exact function, while the dashed line arises from using inappropriate points along the x axis.

```
x = np.linspace(-2, 4, 7)
```

or the simple

```
x = [-2, 0, 1, 2, 4]
```

Any of these x alternatives and a `plot(x, Nv(x))` will result in the solid line in Figure 5.9, which is the correct visualization of the $N(x)$ function.

As in the case of the Heaviside function, it is perhaps best to drop using vectorized evaluations and just draw straight lines between the critical points of the function (since the function is linear):

```
x = [-2, 0, 1, 2, 4]
y = [N(xi) for xi in x]
plot(x, y, 'r', axis=[x[0], x[-1], -0.1, 1.1])
```

5.4.2 Rapidly Varying Functions

Let us now visualize the function $f(x) = \sin(1/x)$, using 10 and 1000 points:

```
def f(x):
    return sin(1.0/x)

from scitools.std import linspace, plot
x1 = linspace(-1, 1, 10)
```

```
x2 = linspace(-1, 1, 1000)
plot(x1, f(x1), label='%d points' % len(x))
plot(x2, f(x2), label='%d points' % len(x))
```

The two plots are shown in Figure 5.10. Using only 10 points gives a completely wrong picture of this function, because the function oscillates faster and faster as we approach the origin. With 1000 points we get an impression of these oscillations, but the accuracy of the plot in the vicinity of the origin is still poor. A plot with 100000 points has better accuracy, in principle, but the extremely fast oscillations near the origin just drown in black ink (you can try it out yourself).

Another problem with the $f(x) = \sin(1/x)$ function is that it is easy to define an x vector containing $x = 0$, such that we get division by zero. Mathematically, the $f(x)$ function has a singularity at $x = 0$: it is difficult to define $f(0)$, so one should exclude this point from the function definition and work with a domain $x \in [-1, -\epsilon] \cup [\epsilon, 1]$, with ϵ chosen small.

The lesson learned from these examples is clear. You must investigate the function to be visualized and make sure that you use an appropriate set of x coordinates along the curve. A relevant first step is to double the number of x coordinates and check if this changes the plot. If not, you probably have an adequate set of x coordinates.

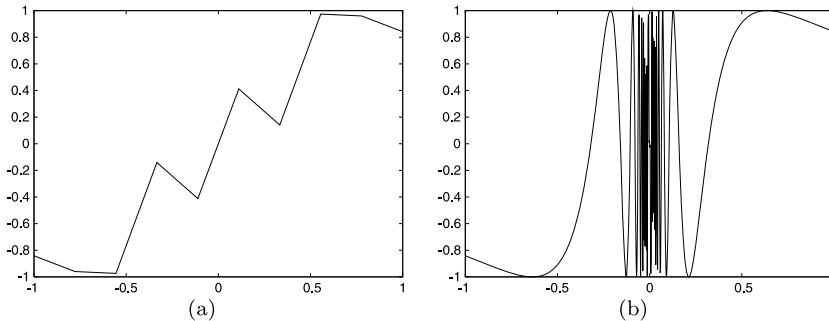

Fig. 5.10 Plot of the function $\sin(1/x)$ with (a) 10 points and (b) 1000 points.

5.5 More Advanced Vectorization of Functions

So far we have seen that vectorization of a Python function $f(x)$ implementing some mathematical function $f(x)$ seems trivial: $f(x)$ works right away with an array argument x and, in that case, returns an array where f is applied to each element in x . When the expression for $f(x)$ is given in terms of a string and the `StringFunction` tool is used to generate the corresponding Python function $f(x)$, one extra step must

be performed to vectorize the Python function. This step is explained in Chapter 5.5.1.

The described vectorization works well as long as the expression $f(x)$ is a mathematical formula without any `if` test. As soon as we have `if` tests (conditional mathematical expressions) the vectorization becomes more challenging. Some useful techniques are explained through two examples in Chapters 5.5.2 and 5.5.3. The described techniques are considered advanced material and only necessary when the time spent on evaluating a function at a very large set of points needs to be significantly decreased.

5.5.1 Vectorizing StringFunction Objects

The `StringFunction` object described in Chapter 4.1.4 does unfortunately not work with array arguments unless we explicitly tell the object to do so. The recipe is very simple. Say `f` is some `StringFunction` object. To allow array arguments we are required to call `f.vectorize(globals())` once:

```
from numpy import *
x = linspace(0, 1, 30)
# f(x) will in general not work

f.vectorize(globals())
values = f(x)           # f works with array arguments
```

It is important that you import everything from `numpy` (or `scitools.std`) *before* calling `f.vectorize`, exactly as shown.

You may take the `f.vectorize` call as a magic recipe. Still, some readers want to know what problem `f.vectorize` solves. Inside the `StringFunction` module we need to have access to mathematical functions for expressions like `sin(x)*exp(x)` to be evaluated. These mathematical functions are by default taken from the `math` module and hence they do not work with array arguments. If the user, in the main program, has imported mathematical functions that work with array arguments, these functions are registered in a dictionary returned from `globals()`. By the `f.vectorize` call we supply the `StringFunction` module with the user's global namespace so that the evaluation of the string expression can make use of the mathematical functions for arrays from the user's program. Unless you use `np.sin(x)*np.cos(x)` etc. in the string formulas, make sure you do a `from numpy import *` so that the function names are defined without any prefix.

Even after calling `f.vectorize(globals())`, a `StringFunction` object may face problems with vectorization. One example is a piecewise constant function as specified by a string expression `'1 if x > 2 else 0'`. Chapter 5.5.2 explains why `if` tests fail for arrays and what the remedies are.

5.5.2 Vectorization of the Heaviside Function

We consider the Heaviside function defined in (3.25) on page 128. The most compact way of implementing this function is

```
def H(x):
    return (0 if x < 0 else 1)
```

Trying to call $H(x)$ with an array argument x fails:

```
>>> def H(x): return (0 if x < 0 else 1)
...
>>> import numpy as np
>>> x = np.linspace(-10, 10, 5)
>>> x
array([-10., -5.,  0.,  5., 10.])
>>> H(x)
...
ValueError: The truth value of an array with more than
one element is ambiguous. Use a.any() or a.all()
```

The problem is related to the test $x < 0$, which results in an array of boolean values, while the `if` test needs a single boolean value (essentially taking `bool(x < 0)`):

```
>>> b = x < 0
>>> b
array([ True,  True, False, False, False], dtype=bool)
>>> bool(b) # evaluate b in a boolean context
...
ValueError: The truth value of an array with more than
one element is ambiguous. Use a.any() or a.all()
>>> b.any() # True if any element in b is True
True
>>> b.all() # True if all elements in b are True
False
```

The `any` and `all` calls do not help us since we want to take actions element by element depending on whether $x[i] < 0$ or not.

There are four ways to find a remedy to our problems with the `if x < 0` test: (i) we can write an explicit loop for computing the elements, (ii) we can use a tool for automatically vectorize $H(x)$, (iii) we can mix boolean and floating-point calculations, or (iv) we can manually vectorize the $H(x)$ function. All four methods will be illustrated next.

Loop. The following function works well for arrays if we insert a simple loop over the array elements (such that $H(x)$ operates on scalars only):

```
def H_loop(x):
    r = np.zeros(len(x))
    for i in xrange(len(x)):
        r[i] = H(x[i])
    return r

# Example:
x = np.linspace(-5, 5, 6)
y = H_loop(x)
```

Automatic Vectorization. Numerical Python contains a method for automatically vectorizing a Python function $H(x)$ that works with scalars (pure numbers) as x argument:

```
import numpy as np
H_vec = np.vectorize(H)
```

The `H_vec(x)` function will now work with vector/array arguments x . Unfortunately, such automatically vectorized functions runs at a fairly slow speed compared to the implementations below (see the end of Chapter 5.5.3 for specific timings).

Mixing Boolean and Floating-Point Calculations. It appears that a very simple solution to vectorizing the $H(x)$ function is to implement it as

```
def H(x):
    return x >= 0
```

The return value is now a `bool` object, not an `int` or `float` as we would mathematically expect to be the proper type of the result. However, the `bool` object works well in both scalar and vectorized operations as long as we involve the returned $H(x)$ in some arithmetic expression. The `True` and `False` values are then interpreted as 1 and 0. Here is a demonstration:

```
>>> x = np.linspace(-1, 1, 5)
>>> H(x)
array([False, False,  True,  True,  True], dtype=bool)
>>> 1*H(x)
array([0, 0, 1, 1, 1])
>>> H(x) - 2
array([-2, -2, -1, -1, -1])
>>>
>>> x = 0.2 # test scalar argument
>>> H(x)
True
>>> 1*H(x)
1
>>> H(x) - 2
-1
```

If returning a boolean value is considered undesirable, we can turn the `bool` object into the proper type by

```
def H(x):
    r = x >= 0
    if isinstance(x, (int,float)):
        return int(r)
    elif isinstance(x, np.ndarray):
        return np.asarray(r, dtype=np.int)
```

Manual Vectorization. By manual vectorization we normally mean translating the algorithm into a set of calls to functions in the `numpy` package such that no loops are visible in the Python code. The last

version of the $H(x)$ is a manual vectorization, but now we shall look at a more general technique when the result is not necessarily 0 or 1. In general, manual vectorization is non-trivial and requires knowledge of and experience with the underlying library for array computations. Fortunately, there is a simple `numpy` recipe for turning functions of the form

```
def f(x):
    if condition:
        r = <expression1>
    else:
        r = <expression2>
    return r
```

into vectorized form:

```
def f_vectorized(x):
    x1 = <expression1>
    x2 = <expression2>
    r = np.where(condition, x1, x2)
    return r
```

The `np.where` function returns an array of the same length as `condition`, whose element no. i equals $x1[i]$ if `condition[i]` is True, and $x2[i]$ otherwise. With Python loops we can express this principle as

```
def my_where(condition, x1, x2):
    r = np.zeros(len(condition)) # result
    for i in xrange(condition):
        r[i] = x1[i] if condition[i] else x2[i]
    return r
```

The `x1` and `x2` variables can be pure numbers too in the call to `np.where`.

In our case we can use the `np.where` function as follows:

```
def Hv(x):
    return np.where(x < 0, 0.0, 1.0)
```

Instead of using `np.where` we can apply *boolean indexing*. The idea is that an array `a` allow to be indexed by an array `b` of boolean values: `a[b]`. The result `a[b]` is a new array with all the elements `a[i]` where `b[i]` is True:

```
>>> a
array([ 0. ,  2.5,  5. ,  7.5, 10. ])
>>> b = a > 5
>>> b
array([False, False, False,  True,  True], dtype=bool)
>>> a[b]
array([ 7.5, 10. ])
```

We can assign new values to the elements in `a` where `b` is True:

```
>>> a[b]
array([ 7.5, 10. ])
>>> a[b] = np.array([-10, -20], dtype=np.float)
>>> a
```

```
array([ 0. ,  2.5,  5. , -10. , -20. ])
>>> a[b] = -4
>>> a
array([ 0. ,  2.5,  5. , -4. , -4. ])
```

To implement the Heaviside function, we start with an array of zeros and then assign 1 to the elements where $x \geq 0$:

```
def Hv(x):
    r = np.zeros(len(x), dtype=np.int)
    r[x >= 0] = 1
    return r
```

5.5.3 Vectorization of a Hat Function

We now turn the attention to the hat function $N(x)$ defined by (3.5) on page 105. The corresponding Python implementation `N(x)` shown right after (3.5) does not work with array arguments x , because the boolean expressions, like $x < 0$, are arrays and they cannot yield a single `True` or `False` value for the `if` tests, as explained in Chapter 5.5.2.

The simplest remedy is to use `np.vectorize` from Chapter 5.5.2:

```
N_vec = np.vectorize(N)
```

It is then important that `N(x)` returns `float` and not `int` values, otherwise the vectorized version will produce `int` values and hence be incorrect.

A manual rewrite, yielding a faster vectorized function, is more demanding than for the Heaviside function because we now have multiple branches in the `if` test. One sketch is to replace

```
if condition1:
    r = <expression1>
elif condition2:
    r = <expression2>
elif condition3:
    r = <expression3>
else:
    r = <expression4>
```

by

```
x1 = <expression1>
x2 = <expression2>
x3 = <expression3>
x4 = <expression4>
r = np.where(condition1, x1, x4) # initialize with "else" expr.
r = np.where(condition2, x2, r)
r = np.where(condition3, x3, r)
```

Alternatively, we can use boolean indexing. Assuming that `<expressionX>` is some expression involving an array x and coded as a Python function `fX(x)` (X is 1, 2, 3, or 4), we can write

```
r = f4(x)
r[condition1] = f1(x[condition1])
r[condition2] = f2(x[condition2])
r[condition3] = f2(x[condition3])
```

Specifically, when the function for scalar arguments x reads

```
def N(x):
    if x < 0:
        return 0.0
    elif 0 <= x < 1:
        return x
    elif 1 <= x < 2:
        return 2 - x
    elif x >= 2:
        return 0.0
```

a vectorized attempt would be

```
def Nv(x):
    r = np.where(x < 0, 0.0, 0.0)
    r = np.where(0 <= x < 1, x, r)
    r = np.where(1 <= x < 2, 2-x, r)
    r = np.where(x >= 2, 0.0, r)
    return r
```

The first and last line are not strictly necessary as we could just start with a zero vector (making the insertion of zeros for the first and last condition a redundant operation).

However, any condition like $0 \leq x < 1$, which is equivalent to $0 \leq x$ and $x < 1$, does not work because the `and` operator does not work with array arguments. Fortunately, there is a simple solution to this problem. All operators in Python (`+`, `-`, `and`, `or`, etc.) are available as pure functions in a module `operator`: `operator.add`, `operator.sub`, `operator.and_`, `operator.or_`¹¹, etc. A working `Nv` function must apply `operator.and_` instead in each condition:

```
import operator

def Nv1(x):
    condition1 = x < 0
    condition2 = operator.and_(0 <= x, x < 1)
    condition3 = operator.and_(1 <= x, x < 2)
    condition4 = x >= 2

    r = np.where(condition1, 0.0, 0.0)
    r = np.where(condition2, x, r)
    r = np.where(condition3, 2-x, r)
    r = np.where(condition4, 0.0, r)
    return r
```

With boolean indexing we get the alternative form

¹¹ Recall that `and` and `or` are reserved keywords, see page 10, so a module or program cannot have variables or functions with these names. To circumvent this problem, the convention is to add a trailing underscore to the name.

```
def Nv2(x):
    condition1 = x < 0
    condition2 = operator.and_(0 <= x, x < 1)
    condition3 = operator.and_(1 <= x, x < 2)
    condition4 = x >= 2

    r = np.zeros(len(x))
    r[condition1] = 0.0
    r[condition2] = x[condition2]
    r[condition3] = 2-x[condition3]
    r[condition4] = 0.0
    return r
```

Again, the first and last assignment to `r` can be omitted in this special case where we start with a zero vector.

The file `hat.py` implements four vectorized versions of the $N(x)$ function: `N_loop`, which is a plain loop calling up $N(x)$ for each `x[i]` element in the array `x`, `N_vec` which is the result of automatic vectorization via `np.vectorize`, the `Nv1` function shown above, which uses the `np.where` constructions, and the `Nv2` function which uses boolean indexing. With a length of `x` of 1,000,000, the results on my computer¹² became 4.8 s for `N_loop`, 1 s `N_vec`, 0.3 s for `Nv1`, and 0.08 s for `Nv2`. Boolean indexing is clearly the fastest method.

5.6 More on Numerical Python Arrays

This section lists some more advanced but useful operations with Numerical Python arrays.

5.6.1 Copying Arrays

Let `x` be an array. The statement `a = x` makes `a` refer to the same array as `x`. Changing `a` will then also affect `x`:

```
>>> import numpy as np
>>> x = np.array([1, 2, 3.5])
>>> a = x
>>> a[-1] = 3 # this changes x[-1] too!
>>> x
array([ 1.,  2.,  3.])
```

Changing `a` without changing `x` requires `a` to be a copy of `x`:

```
>>> a = x.copy()
>>> a[-1] = 9
>>> a
array([ 1.,  2.,  9.])
>>> x
array([ 1.,  2.,  3.])
```

¹² MacBook Air 11", 1.6 GHz Intel CPU, running Ubuntu in a VMWare virtual machine.

5.6.2 In-Place Arithmetics

Let `a` and `b` be two arrays of the same shape. The expression `a += b` means `a = a + b`, but this is not the complete story. In the statement `a = a + b`, the sum `a + b` is first computed, yielding a new array, and then the name `a` is bound to this new array. The old array `a` is lost unless there are other names assigned to this array. In the statement `a += b`, elements of `b` are added directly into the elements of `a` (in memory). There is no hidden intermediate array as in `a = a + b`. This implies that `a += b` is more efficient than `a = a + b` since Python avoids making an extra array. We say that the operators `+=`, `*=`, and so on, perform *in-place* arithmetics in arrays.

Consider the compound array expression

```
a = (3*x**4 + 2*x + 4)/(x + 1)
```

The computation actually goes as follows with seven hidden arrays for storing intermediate results:

1. `r1 = x**4`
2. `r2 = 3*r1`
3. `r3 = 2*x`
4. `r4 = r2 + r3`
5. `r5 = r4 + 4`
6. `r6 = x + 1`
7. `r7 = r5/r6`
8. `a = r7`

With in-place arithmetics we can get away with creating three new arrays, at a cost of a significantly less readable code:

```
a = x.copy()
a **= 4
a *= 3
a += 2*x
a += 4
a /= x + 1
```

The three extra arrays in this series of statement arise from copying `x`, and computing the right-hand sides `2*x` and `x+1`.

Quite often in computational science and engineering, a huge number of arithmetics is performed on very large arrays, and then saving memory and array allocation time by doing in-place arithmetics is important.

The mix of assignment and in-place arithmetics makes it easy to make unintended changes of more than one array. For example, this code changes `x`:

```
a = x
a += y
```

since `a` refers to the same array as `x` and the change of `a` is done in-place.

5.6.3 Allocating Arrays

We have already seen that the `np.zeros` function is handy for making a new array `a` of a given size. Very often the size and the type of array elements have to match another existing array `x`. We can then either copy the original array, e.g.,

```
a = x.copy()
```

and fill elements in `a` with the right new values, or we can say

```
a = np.zeros(x.shape, x.dtype)
```

The attribute `x.dtype` holds the array element type (`dtype` for data type), and as mentioned before, `x.shape` is a tuple with the array dimensions.

Sometimes we may want to ensure that an object is an array, and if not, turn it into an array. The `np.asarray` function is useful in such cases:

```
a = np.asarray(a)
```

Nothing is copied if `a` already is an array, but if `a` is a list or tuple, a new array with a copy of the data is created.

5.6.4 Generalized Indexing

Chapter 5.2.2 shows how slices can be used to extract and manipulate subarrays. The slice `f:t:i` corresponds to the index set `f, f+i, f+2*i, ...` up to, but not including, `t`. Such an index set can be given explicitly too: `a[range(f,t,i)]`. That is, the integer list from `range` can be used as a set of indices. In fact, any integer list or integer array can be used as index:

```
>>> a = np.linspace(1, 8, 8)
>>> a
array([ 1.,  2.,  3.,  4.,  5.,  6.,  7.,  8.])
>>> a[[1,6,7]] = 10
>>> a
array([ 1., 10.,  3.,  4.,  5.,  6., 10., 10.])
>>> a[range(2,8,3)] = -2 # same as a[2:8:3] = -2
>>> a
array([ 1., 10., -2.,  4.,  5., -2., 10., 10.])
```

We can also use boolean arrays to generate an index set. The indices in the set will correspond to the indices for which the boolean array has `True` values. This functionality allows expressions like `a[x<m]`. Here are two examples, continuing the previous interactive session:

```

>>> a[a < 0]          # pick out the negative elements of a
array([-2., -2.])
>>> a[a < 0] = a.max()
>>> a
array([ 1., 10., 10.,  4.,  5., 10., 10., 10.])
>>> # Replace elements where a is 10 by the first
>>> # elements from another array/list:
>>> a[a == 10] = [10, 20, 30, 40, 50, 60, 70]
>>> a
array([ 1., 10., 20.,  4.,  5., 30., 40., 50.])

```

Generalized indexing using integer arrays or lists is important for vectorized initialization of array elements. The syntax for generalized indexing of higher-dimensional arrays is slightly different, see Chapter 5.7.2.

5.6.5 Testing for the Array Type

Inside an interactive Python shell you can easily check an object's type using the `type` function (see Chapter 1.5.2). In case of a Numerical Python array, the type name is `ndarray`:

```

>>> a = np.linspace(-1, 1, 3)
>>> a
array([-1.,  0.,  1.])
>>> type(a)
<type 'numpy.ndarray'>

```

Sometimes you need to test if a variable is an `ndarray` or a `float` or `int`. The `isinstance` function can be used this purpose:

```

>>> isinstance(a, np.ndarray)
True
>>> isinstance(a, (float,int)) # float or int?
False

```

A typical use of `isinstance` and `type` to check on object's type is shown next.

Example: Vectorizing a Constant Function. Suppose we have a constant function,

```

def f(x):
    return 2

```

This function accepts an array argument `x`, but will return a `float` while a vectorized version of the function should return an array of the same shape as `x` where each element has the value 2. The vectorized version can be realized as

```

def fv(x):
    return np.zeros(x.shape, x.dtype) + 2

```

The optimal vectorized function would be one that works for both a scalar and an array argument. We must then test on the argument type:

```
def f(x):
    if isinstance(x, (float, int)):
        return 2
    elif isinstance(x, np.ndarray):
        return np.zeros(x.shape, x.dtype) + 2
    else:
        raise TypeError\
            ('x must be int, float or ndarray, not %s' % type(x))
```

5.6.6 Compact Syntax for Array Generation

There is a special compact syntax `r_[f:t:s]` for the `linspace` function:

```
>>> a = r_[-5:5:11j] # same as linspace(-5, 5, 11)
>>> print a
[-5. -4. -3. -2. -1.  0.  1.  2.  3.  4.  5.]
```

Here, `11j` means 11 coordinates (between -5 and 5 , including the upper limit 5). That is, the number of elements in the array is given with the imaginary number syntax.

5.6.7 Shape Manipulation

The `shape` attribute in array objects holds the shape, i.e., the size of each dimension. A function `size` returns the total number of elements in an array. Here are a few equivalent ways of changing the shape of an array:

```
>>> a = np.linspace(-1, 1, 6)
>>> print a
[-1. -0.6 -0.2  0.2  0.6  1. ]
>>> a.shape
(6,)
>>> a.size
6
>>> a.shape = (2, 3)
>>> a = a.reshape(2, 3) # alternative
>>> a.shape
(2, 3)
>>> print a
[[-1. -0.6 -0.2]
 [ 0.2  0.6  1. ]]
>>> a.size # total no of elements
6
>>> len(a) # no of rows
2
>>> a.shape = (a.size,) # reset shape
```

Note that `len(a)` always returns the length of the first dimension of an array.

5.7 Higher-Dimensional Arrays

5.7.1 Matrices and Arrays

Vectors appeared when mathematicians needed to calculate with a list of numbers. When they needed a table (or a list of lists in Python terminology), they invented the concept of *matrix* (singular) and *matrices* (plural). A table of numbers has the numbers ordered into rows and columns. One example is

$$\begin{bmatrix} 0 & 12 & -1 & 5 \\ -1 & -1 & -1 & 0 \\ 11 & 5 & 5 & -2 \end{bmatrix}$$

This table with three rows and four columns is called a 3×4 matrix¹³. If the symbol A is associated with this matrix, $A_{i,j}$ denotes the number in row number i and column number j . Counting rows and columns from 0, we have, for instance, $A_{0,0} = 0$ and $A_{2,3} = -2$. We can write a general $m \times n$ matrix A as

$$\begin{bmatrix} A_{0,0} & \cdots & A_{0,n-1} \\ \vdots & \ddots & \vdots \\ A_{m-1,0} & \cdots & A_{m-1,n-1} \end{bmatrix}$$

Matrices can be added and subtracted. They can also be multiplied by a scalar (a number), and there is a concept of “length”. The formulas are quite similar to those presented for vectors, but the exact form is not important here.

We can generalize the concept of table and matrix to *array*, which holds quantities with in general d indices. Equivalently we say that the array has rank d . For $d = 3$, an array A has elements with three indices: $A_{p,q,r}$. If p goes from 0 to $n_p - 1$, q from 0 to $n_q - 1$, and r from 0 to $n_r - 1$, the A array has $n_p \times n_q \times n_r$ elements in total. We may speak about the *shape* of the array, which is a d -vector holding the number of elements in each “array direction”, i.e., the number of elements for each index. For the mentioned A array, the shape is (n_p, n_q, n_r) .

The special case of $d = 1$ is a vector, and $d = 2$ corresponds to a matrix. When we program we may skip thinking about vectors and matrices (if you are not so familiar with these concepts from a mathematical point of view) and instead just work with arrays. The number of indices corresponds to what is convenient in the programming problem we try to solve.

¹³ Mathematicians don’t like this sentence, but it suffices for our purposes.

5.7.2 Two-Dimensional Numerical Python Arrays

Recall the nested list from Chapter 2.4, where `[C, F]` pairs are elements in a list `table`. The construction of `table` goes as follows:

```
>>> Cdegrees = [-30 + i*10 for i in range(3)]
>>> Fdegrees = [9./5*C + 32 for C in Cdegrees]
>>> table = [[C, F] for C, F in zip(Cdegrees, Fdegrees)]
>>> print table
[[-30, -22.0], [-20, -4.0], [-10, 14.0]]
```

Note that the `table` list is a nested list. This nested list can be turned into an array,

```
>>> table2 = np.array(table)
>>> print table2
[[-30. -22.]
 [-20.  -4.]
 [-10.  14.]]
>>> type(table2)
<type 'numpy.ndarray'>
```

We say that `table2` is a *two-dimensional* array, or an array of rank 2.

The `table` list and the `table2` array are stored very differently in memory. The `table` variable refers to a list object containing three elements. Each of these elements is a reference to a separate list object with two elements, where each element refers to a separate `float` object. The `table2` variable is a reference to a single array object that again refers to a consecutive sequence of bytes in memory where the six floating-point numbers are stored. The data associated with `table2` are found in one “chunk” in the computer’s memory, while the data associated with `table` are scattered around in memory. On today’s machines, it is much more expensive to find data in memory than to compute with the data. Arrays make the data fetching more efficient, and this is major reason for using arrays. However, this efficiency gain is only present for very large arrays, not for a 3×2 array.

Indexing a nested list is done in two steps, first the outer list is indexed, giving access to an element that is another list, and then this latter list is indexed:

```
>>> table[1][0]      # table[1] is [-20,4], whose index 0 holds -20
-20
```

This syntax works for two-dimensional arrays too:

```
>>> table2[1][0]
-20.0
```

but there is another syntax which is more common for arrays:

```
>>> table2[1,0]
-20.0
```

A two-dimensional array reflects a table and has a certain number of “rows” and “columns”. We refer to “rows” as the *first dimension* of the array and “columns” as the *second dimension*. These two dimensions are available as `table2.shape`:

```
>>> table2.shape
(3, 2)
```

Here, 3 is the number of “rows” and 2 is the number of “columns”.

A loop over all the elements in a two-dimensional array is usually expressed as two *nested* for loops, one for each index:

```
>>> for i in range(table2.shape[0]):
...     for j in range(table2.shape[1]):
...         print 'table2[%d,%d] = %g' % (i, j, table2[i,j])
...
table2[0,0] = -30
table2[0,1] = -22
table2[1,0] = -20
table2[1,1] = -4
table2[2,0] = -10
table2[2,1] = 14
```

An alternative (but less efficient) way of visiting each element in an array with any number of dimensions makes use of a single for loop:

```
>>> for index_tuple, value in np.ndenumerate(table2):
...     print 'index %s has value %g' % \
...         (index_tuple, table2[index_tuple])
...
index (0,0) has value -30
index (0,1) has value -22
index (1,0) has value -20
index (1,1) has value -4
index (2,0) has value -10
index (2,1) has value 14
```

In the same way as we can extract sublists of lists, we can extract subarrays of arrays using slices.

```
table2[0:table2.shape[0], 1] # 2nd column (index 1)
array([-22., -4., 14.])

>>> table2[0:, 1]           # same
array([-22., -4., 14.])

>>> table2[:, 1]           # same
array([-22., -4., 14.])
```

To illustrate array slicing further, we create a bigger array:

```
>>> t = np.linspace(1, 30, 30).reshape(5, 6)
>>> t
array([[ 1.,  2.,  3.,  4.,  5.,  6.],
       [ 7.,  8.,  9., 10., 11., 12.],
       [13., 14., 15., 16., 17., 18.],
       [19., 20., 21., 22., 23., 24.],
       [25., 26., 27., 28., 29., 30.]])
```

```
>>> t[1:-1:2, 2:]
array([[ 9., 10., 11., 12.],
       [21., 22., 23., 24.]])
```

To understand the slice, look at the original `t` array and pick out the two rows corresponding to the first slice `1:-1:2`,

```
[ 7.,  8.,  9., 10., 11., 12.]
 [19., 20., 21., 22., 23., 24.]
```

Among the rows, pick the columns corresponding to the second slice `2:`,

```
[ 9., 10., 11., 12.]
 [21., 22., 23., 24.]
```

Another example is

```
>>> t[:-2, :-1:2]
array([[ 1.,  3.,  5.],
       [ 7.,  9., 11.],
       [13., 15., 17.]])
```

Generalized indexing as described for one-dimensional arrays in Chapter 5.6.4 requires a more comprehensive syntax for higher-dimensional arrays. Say we want to extract a subarray of `t` that consists of the rows with indices 0 and 3 and the columns with indices 1 and 2:

```
>>> t[np.ix_([0,3], [1,2])]
array([[ 2.,  3.],
       [20., 21.]])
>>> t[np.ix_([0,3], [1,2])] = 0
>>> t
array([[ 1.,  0.,  0.,  4.,  5.,  6.],
       [ 7.,  8.,  9., 10., 11., 12.],
       [13., 14., 15., 16., 17., 18.],
       [19.,  0.,  0., 22., 23., 24.],
       [25., 26., 27., 28., 29., 30.]])
```

Recall that slices only gives a view to the array, not a copy of the values:

```
>>> a = t[1:-1:2, 1:-1]
>>> a
array([[ 8.,  9., 10., 11.],
       [ 0.,  0., 22., 23.]])
>>> a[:, :] = -99
>>> a
array([[ -99., -99., -99., -99.],
       [-99., -99., -99., -99.]])
>>> t # is t changed to? yes!
array([[ 1.,  0.,  0.,  4.,  5.,  6.],
       [ 7., -99., -99., -99., -99., 12.],
       [13., 14., 15., 16., 17., 18.],
       [19., -99., -99., -99., -99., 24.],
       [25., 26., 27., 28., 29., 30.]])
```

5.7.3 Array Computing

The operations on vectors in Chapter 5.1.3 can quite straightforwardly be extended to arrays of any dimension. Consider the definition of applying a function $f(v)$ to a vector v : we apply the function to each element v_i in v . For a two-dimensional array A with elements $A_{i,j}$, $i = 0, \dots, m$, $j = 0, \dots, n$, the same definition yields

$$f(A) = (f(A_{0,0}), \dots, f(A_{m-1,0}), f(A_{1,0}), \dots, f(A_{m-1,n-1})).$$

For an array B with any rank, $f(B)$ means applying f to each array entry.

The asterisk operation from Chapter 5.1.3 is also naturally extended to arrays: $A * B$ means multiplying an element in A by the corresponding element in B , i.e., element (i, j) in $A * B$ is $A_{i,j}B_{i,j}$. This definition naturally extends to arrays of any rank, provided the two arrays have the same shape.

Adding a scalar to an array implies adding the scalar to each element in the array. Compound expressions involving arrays, e.g., $\exp(-A * *2) * A + 1$, work as for vectors. One can in fact just imagine that all the array elements are stored after each other in a long vector¹⁴, and the array operations can then easily be defined in terms of the vector operations from Chapter 5.1.3.

Remark. Readers with knowledge of matrix computations may ask how an expression like A^2 interfere with $A**2$. In matrix computing, A^2 is a matrix-matrix product, which is very different from squaring each element in A as $A**2$ or $A*A$ implies. Fortunately, the matrix computing operations look different from the array computing operations in mathematical typesetting. In a program, however, $A*A$ and $A**2$ are identical computations, but the first one could lead to a confusion with a matrix-matrix product AA . With NumPy arrays the matrix-matrix product is obtained by `dot(A, A)`. The matrix-vector product Ax , where x is a vector, is computed by `dot(A, x)`. With matrix objects (see Chapter 5.7.5) $A*A$ implies the mathematical matrix multiplication AA .

5.7.4 Two-Dimensional Arrays and Functions of Two Variables

Given a function of two variables, say

```
def f(x, y):
    return sin(sqrt(x**2 + y**2))
```

we can plot this function by writing

¹⁴ This is the way the array elements are stored in the computer's memory.

```

from scitools.std import sin, sqrt, linspace, ndgrid, mesh
x = y = linspace(-5, 5, 21) # coordinates in x and y direction
xv, yv = ndgrid(x, y)
z = f(xv, yv)
mesh(xv, yv, z)

```

There are two new things here: (i) the call to `ndgrid`, which is necessary to transform one-dimensional coordinate arrays in the x and y direction into arrays valid for evaluating f over a two-dimensional grid; and (ii) the plot function whose name now is `mesh`, which is one out of many plot functions for two-dimensional functions. Another plot type you can try out is

```
surf(xv, yv, z)
```

More material on visualizing $f(x, y)$ functions is found in the section “Visualizing Scalar Fields” in the Easyviz tutorial. This tutorial can be reached through the command `pydoc scitools.easyviz` in a terminal window or from Googlecode.

5.7.5 Matrix Objects

This section only makes sense if you are familiar with basic linear algebra and the matrix concept. The arrays created so far have been of type `ndarray`. NumPy also has a matrix type called `matrix` or `mat` for one- and two-dimensional arrays. One-dimensional arrays are then extended with one extra dimension such that they become matrices, i.e., either a row vector or a column vector:

```

>>> import numpy as np
>>> x1 = np.array([1, 2, 3], float)
>>> x2 = np.matrix(x1) # or mat(x1)
>>> x2 # row vector
matrix([[ 1.,  2.,  3.]])
>>> x3 = mat(x).transpose() # column vector
>>> x3
matrix([[ 1.],
        [ 2.],
        [ 3.]])

>>> type(x3)
<class 'numpy.matrixlib.defmatrix.matrix'>
>>> isinstance(x3, np.matrix)
True

```

A special feature of `matrix` objects is that the multiplication operator represents the matrix-matrix, vector-matrix, or matrix-vector product as we know from linear algebra:

```

>>> A = eye(3) # identity matrix
>>> A
array([[ 1.,  0.,  0.],
       [ 0.,  1.,  0.],
       [ 0.,  0.,  1.]])

```

```

>>> A = mat(A)
>>> A
matrix([[ 1.,  0.,  0.],
        [ 0.,  1.,  0.],
        [ 0.,  0.,  1.]])
>>> y2 = x2*A          # vector-matrix product
>>> y2
matrix([[ 1.,  2.,  3.]])
>>> y3 = A*x3          # matrix-vector product
>>> y3
matrix([[ 1.],
        [ 2.],
        [ 3.]])

```

One should note here that the multiplication operator between standard `ndarray` objects is quite different, as the next interactive session demonstrates.

```

>>> A*x1                # no matrix-array product!
Traceback (most recent call last):
...
ValueError: matrices are not aligned

>>> # try array*array product:
>>> A = (zeros(9) + 1).reshape(3,3)
>>> A
array([[ 1.,  1.,  1.],
       [ 1.,  1.,  1.],
       [ 1.,  1.,  1.]])
>>> A*x1                # [A[0,:]*x1, A[1,:]*x1, A[2,:]*x1]
array([[ 1.,  2.,  3.],
       [ 1.,  2.,  3.],
       [ 1.,  2.,  3.]])
>>> B = A + 1
>>> A*B                # element-wise product
array([[ 2.,  2.,  2.],
       [ 2.,  2.,  2.],
       [ 2.,  2.,  2.]])
>>> A = mat(A); B = mat(B)
>>> A*B                # matrix-matrix product
matrix([[ 6.,  6.,  6.],
        [ 6.,  6.,  6.],
        [ 6.,  6.,  6.]])

```

Readers who are familiar with Matlab, or intend to use Python and Matlab together, should seriously think about programming with `matrix` objects instead of `ndarray` objects, because the `matrix` type behaves quite similar to matrices and vectors in Matlab. Nevertheless, `matrix` cannot be used for arrays of larger dimension than two.

5.8 Summary

5.8.1 Chapter Topics

This chapter has introduced computing with arrays and plotting curve data stored in arrays. The Numerical Python package contains lots of functions for array computing, including the ones listed in Table 5.1. Plotting has been done with tools that resemble the syntax of Matlab.

Table 5.1 Summary of important functionality for Numerical Python arrays.

<code>array(1d)</code>	copy list data <code>1d</code> to a <code>numpy</code> array
<code>asarray(d)</code>	make array of data <code>d</code> (copy if list, no copy if already array)
<code>zeros(n)</code>	make a <code>float</code> vector/array of length <code>n</code> , with zeros
<code>zeros(n, int)</code>	make an <code>int</code> vector/array of length <code>n</code> with zeros
<code>zeros((m,n))</code>	make a two-dimensional <code>float</code> array with shape <code>(m,n)</code>
<code>zeros(x.shape, x.dtype)</code>	make array of same shape as <code>x</code> and same element data type
<code>linspace(a,b,m)</code>	uniform sequence of <code>m</code> numbers between <code>a</code> and <code>b</code> (<code>b</code> is included in the sequence)
<code>a.shape</code>	tuple containing <code>a</code> 's shape
<code>a.size</code>	total no of elements in <code>a</code>
<code>len(a)</code>	length of a one-dim. array <code>a</code> (same as <code>a.shape[0]</code>)
<code>a.reshape(3,2)</code>	return <code>a</code> reshaped as 3×2 array
<code>a[i]</code>	vector indexing
<code>a[i,j]</code>	two-dim. array indexing
<code>a[1:k]</code>	slice: reference data with indices $1, \dots, k-1$
<code>a[1:8:3]</code>	slice: reference data with indices $1, 4, \dots, 7$
<code>b = a.copy()</code>	copy an array
<code>sin(a), exp(a), ...</code>	<code>numpy</code> functions applicable to arrays
<code>c = concatenate((a, b))</code>	<code>c</code> contains <code>a</code> with <code>b</code> appended
<code>c = where(cond, a1, a2)</code>	<code>c[i] = a1[i]</code> if <code>cond[i]</code> , else <code>c[i] = a2[i]</code>
<code>isinstance(a, ndarray)</code>	is <code>True</code> if <code>a</code> is an array

Array Computing. When we apply a Python function $f(x)$ to a Numerical Python array `x`, the result is the same as if we apply `f` to each element in `x` separately. However, when `f` contains `if` statements, these are in general invalid if an array `x` enters the boolean expression. We then have to rewrite the function, often by applying the `where` function from Numerical Python.

Plotting Curves. Chapters 5.3.1 and 5.3.2 provide a quick overview of how to plot curves with the aid of Matplotlib. The same examples coded with the Easyviz plotting interface appear in Chapter 5.3.3.

Making Movies. Each frame in a movie must be a hardcopy of a plot, i.e., a plotfile in some standard format such as PNG or PostScript. These plotfiles should have names containing a counter padded with leading zeros. One example may be `forceplot_0001.eps`, `forceplot_0002.eps`. Having the plotfiles with names on this form, we can make a movie file `movie.gif` with two frames per second by the `movie` function from Easyviz (from `scitools.std import movie`):

```
movie('forceplot_*.png', encoder='convert',
      output_file='movie.gif', fps=2)
```

The resulting movie, in the animated GIF format, can be shown in a web page or displayed by the `animate` program.

Other movie formats can be produced by using other encoders, e.g., `ppmtompeg` and `ffmpeg` for the MPEG format, or `mencoder` for the AVI

format. There are lots of options to the `movie` function, which you can see by writing `pydoc scitools.easyviz.movie` (see page 78 for how to run such a command).

5.8.2 Example: Animating a Function

Problem. In this chapter's summarizing example we shall visualize how the temperature varies downward in the earth as the surface temperature oscillates between high day and low night values. One question may be: What is the temperature change 10 m down in the ground if the surface temperature varies between 2 C in the night and 15 C in the day?

Let the z axis point downwards, towards the center of the earth, and let $z = 0$ correspond to the earth's surface. The temperature at some depth z in the ground at time t is denoted by $T(z, t)$. If the surface temperature has a periodic variation around some mean value T_0 , according to

$$T(0, t) = T_0 + A \cos(\omega t),$$

one can find, from a mathematical model for heat conduction, that the temperature at an arbitrary depth is

$$T(z, t) = T_0 + Ae^{-az} \cos(\omega t - az), \quad a = \sqrt{\frac{\omega}{2k}}. \quad (5.13)$$

The parameter k reflects the ground's ability to conduct heat (k is called the *thermal diffusivity* or the *heat conduction coefficient*).

The task is to make an animation of how the temperature profile in the ground, i.e., T as a function of z , varies in time. Let ω correspond to a time period of 24 hours. The mean temperature T_0 is taken as 10 C, and the maximum variation A is assumed to be 10 C. The heat conduction coefficient k may be set as 1 mm²/s (which is 10⁻⁶ m²/s in proper SI units).

Solution. To animate $T(z, t)$ in time, we need to make a loop over points in time, and in each pass in the loop we must save a plot of T , as a function of z , to file. The plot files can then be combined to a movie. The algorithm becomes

```
for  $t_i = i\Delta t$ ,  $i = 0, 1, 2, \dots, n$ :
    plot the curve  $y(z) = T(z, t_i)$ 
    store the plot in a file
combine all the plot files into a movie
```

It can be wise to make a general `animate` function where we just feed in some $f(x, t)$ function and make all the plot files. If `animate` has

arguments for setting the labels on the axis and the extent of the y axis, we can easily use `animate` also for a function $T(z, t)$ (we just use z as the name for the x axis and T as the name for the y axis in the plot). Recall that it is important to fix the extent of the y axis in a plot when we make animations, otherwise most plotting programs will automatically fit the extent of the axis to the current data, and the tick marks on the y axis will jump up and down during the movie. The result is a wrong visual impression of the function.

The names of the plot files must have a common stem appended with some frame number, and the frame number should have a fixed number of digits, such as 0001, 0002, etc. (if not, the sequence of the plot files will not be correct when we specify the collection of files with an asterisk for the frame numbers, e.g., as in `tmp*.png`). We therefore include an argument to `animate` for setting the name stem of the plot files. By default, the stem is `tmp_`, resulting in the filenames `tmp_0000.png`, `tmp_0001.png`, `tmp_0002.png`, and so forth. Other convenient arguments for the `animate` function are the initial time in the plot, the time lag Δt between the plot frames, and the coordinates along the x axis. The `animate` function then takes the form

```
def animate(tmax, dt, x, function, ymin, ymax, t0=0,
           xlabel='x', ylabel='y', filename='tmp_'):
    t = t0
    counter = 0
    while t <= tmax:
        y = function(x, t)
        plot(x, y,
             axis=[x[0], x[-1], ymin, ymax],
             title='time=%2d h' % (t/3600.0),
             xlabel=xlabel, ylabel=ylabel,
             savefig=filename + '%04d.png' % counter)
        t += dt
        counter += 1
```

The $T(z, t)$ function is easy to implement, but we need to decide whether the parameters A , ω , T_0 , and k shall be arguments to the Python implementation of $T(z, t)$ or if they shall be global variables. Since the `animate` function expects that the function to be plotted has only two arguments, we must implement $T(z, t)$ as `T(z,t)` in Python and let the other parameters be global variables (Chapters 7.1.1 and 7.1.2 explain this problem in more detail and present a better implementation). The `T(z,t)` implementation then reads

```
def T(z, t):
    # T0, A, k, and omega are global variables
    a = sqrt(omega/(2*k))
    return T0 + A*exp(-a*z)*cos(omega*t - a*z)
```

Suppose we plot $T(z, t)$ at n points for $z \in [0, D]$. We make such plots for $t \in [0, t_{\max}]$ with a time lag Δt between the them. The frames in the movie are now made by

```
# set T0, A, k, omega, D, n, tmax, dt
z = linspace(0, D, n)
animate(tmax, dt, z, T, T0-A, T0+A, 0, 'z', 'T')
```

We have here set the extent of the y axis in the plot as $[T_0 - A, T_0 + A]$, which is in accordance with the $T(z, t)$ function.

The call to `animate` above creates a set of files with names of the form `tmp_*.png`. The animation is then created by a call

```
movie('tmp_*.png', encoder='convert', fps=2,
      output_file='tmp_heatwave.gif')
```

It now remains to assign proper values to all the global variables in the program: n , D , T_0 , A , ω , dt , t_{\max} , and k . The oscillation period is 24 hours, and ω is related to the period P of the cosine function by $\omega = 2\pi/P$ (realize that $\cos(t2\pi/P)$ has period P). We then express $P = 24 \text{ h} = 24 \cdot 60 \cdot 60 \text{ s}$ and compute $\omega = 2\pi/P$. The total simulation time can be 3 periods, i.e., $t_{\max} = 3P$. The $T(z, t)$ function decreases exponentially with the depth z so there is no point in having the maximum depth D larger than the depth where T is approximately zero, say 0.001. We have that $e^{-aD} = 0.001$ when $D = -a^{-1} \ln 0.001$, so we can use this estimate in the program. The proper initialization of all parameters can then be expressed as follows¹⁵:

```
k = 1E-6      # thermal diffusivity (in m*m/s)
P = 24*60*60.# oscillation period of 24 h (in seconds)
omega = 2*pi/P
dt = P/24     # time lag: 1 h
tmax = 3*P    # 3 day/night simulation
T0 = 10       # mean surface temperature in Celsius
A = 10        # amplitude of the temperature variations in Celsius
a = sqrt(omega/(2*k))
D = -(1/a)*log(0.001) # max depth
n = 501       # no of points in the z direction
```

We encourage you to run the program `heatwave.py` to see the movie. The hardcopy of the movie is in the file `tmp_heatwave.gif`. Figure 5.11 displays two snapshots in time of the $T(z, t)$ function.

Scaling. In this example, as in many other scientific problems, it was easier to write the code than to assign proper physical values to the input parameters in the program. To learn about the physical process, here how heat propagates from the surface and down in the ground, it is often advantageous to scale the variables in the problem so that we work with dimensionless variables. Through the scaling procedure we normally end up with much fewer physical parameters which must be assigned values. Let us show how we can take advantage of scaling the present problem.

¹⁵ Note that it is very important to use consistent units. Here we express all units in terms of meter, second, and Kelvin or Celsius.

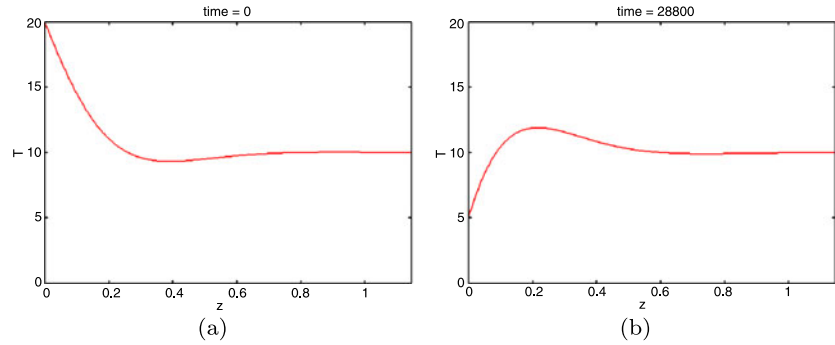

Fig. 5.11 Plot of the temperature $T(z, t)$ in the ground for two different t values.

Consider a variable x in a problem with some dimension. The idea of scaling is to introduce a new variable $\bar{x} = x/x_c$, where x_c is a *characteristic size* of x . Since x and x_c have the same dimension, the dimension cancels in \bar{x} such that \bar{x} is dimensionless. Choosing x_c to be the expected maximum value of x , ensures that $\bar{x} \leq 1$, which is usually considered a good idea. That is, we try to have all dimensionless variables varying between zero and one. For example, we can introduce a dimensionless z coordinate: $\bar{z} = z/D$, and now $\bar{z} \in [0, 1]$. Doing a proper scaling of a problem is challenging so for now it is sufficient to just follow the steps below – and not worry why we choose a certain scaling.

In the present problem we introduce these dimensionless variables:

$$\begin{aligned}\bar{z} &= z/D \\ \bar{T} &= \frac{T - T_0}{A} \\ \bar{t} &= \omega t\end{aligned}$$

We now insert $z = \bar{z}D$ and $t = \bar{t}/\omega$ in the expression for $T(z, t)$ and get

$$T = T_0 + Ae^{-b\bar{z}} \cos(\bar{t} - b\bar{z}), \quad b = aD$$

or

$$\bar{T}(\bar{z}, \bar{t}) = \frac{T - T_0}{A} = e^{-b\bar{z}} \cos(\bar{t} - b\bar{z}).$$

We see that \bar{T} depends on only *one* dimensionless parameter b in addition to the independent dimensionless variables \bar{z} and \bar{t} . It is common practice at this stage of the scaling to just drop the bars and write

$$T(z, t) = e^{-bz} \cos(t - bz). \quad (5.14)$$

This function is much simpler to plot than the one with lots of physical parameters, because now we know that T varies between -1 and 1 , t varies between 0 and 2π for one period, and z varies between 0 and 1 .

The scaled temperature has only one “free” parameter b . That is, the shape of the graph is completely determined by b .

In our previous movie example, we used specific values for D , ω , and k , which then implies a certain $b = D\sqrt{\omega/(2k)}$ (≈ 6.9). However, we can now run different b values and see the effect on the heat propagation. Different b values will in our problems imply different periods of the surface temperature variation and/or different heat conduction values in the ground’s composition of rocks. Note that doubling ω and k leaves the same b – it is only the fraction ω/k that influences the value of b .

We can reuse the `animate` function also in the scaled case, but we need to make a new $T(z, t)$ function and, e.g., a main program where b can be read from the command line:

```
def T(z, t):
    return exp(-b*z)*cos(t - b*z) # b is global

b = float(sys.argv[1])
n = 401
z = linspace(0, 1, n)
animate(3*2*pi, 0.05*2*pi, z, T, -1.2, 1.2, 0, 'z', 'T')
movie('tmp*.png', encoder='convert', fps=2,
      output_file='tmp_heatwave.gif')
```

Running the program, found as the file `heatwave_scaled.py`, for different b values shows that b governs how deep the temperature variations on the surface $z = 0$ penetrate. A large b makes the temperature changes confined to a thin layer close to the surface (see Figure 5.12 for $b = 20$), while a small b leads to temperature variations also deep down in the ground (see Figure 5.13 for $b = 2$).

We can understand the results from a physical perspective. Think of increasing ω , which means reducing the oscillation period so we get a more rapid temperature variation. To preserve the value of b we must increase k by the same factor. Since a large k means that heat quickly spreads down in the ground, and a small k implies the opposite, we see that more rapid variations at the surface requires a larger k to more quickly conduct the variations down in the ground. Similarly, slow temperature variations on the surface can penetrate deep in the ground even if the ground’s ability to conduct (k) is low.

5.9 Exercises

Exercise 5.1. *Fill lists with function values.*

Define

$$h(x) = \frac{1}{\sqrt{2\pi}} e^{-\frac{1}{2}x^2}. \quad (5.15)$$

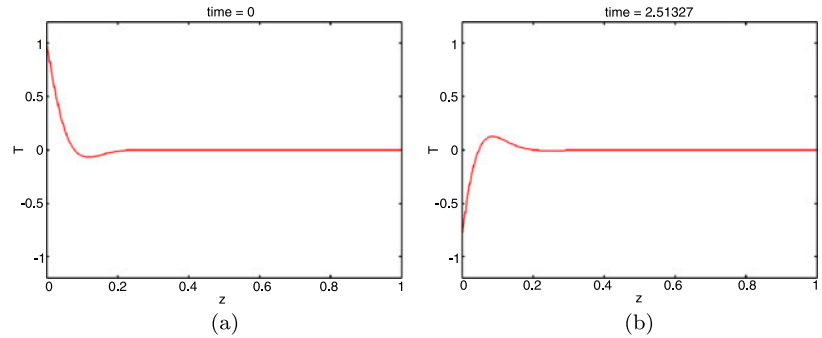

Fig. 5.12 Plot of the dimensionless temperature $T(z, t)$ in the ground for two different t values and $b = 20$.

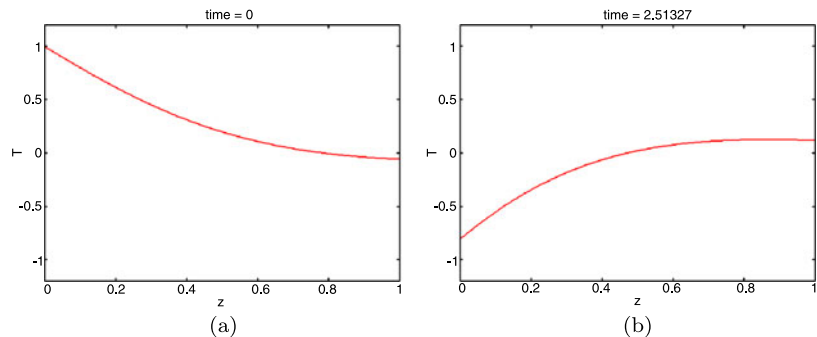

Fig. 5.13 Plot of the dimensionless temperature $T(z, t)$ in the ground for two different t values and $b = 2$.

Fill lists `xlist` and `hlist` with x and $h(x)$ values for 41 uniformly spaced x coordinates in $[-4, 4]$. Hint: You may adapt the example in Chapter 5.2.1. Name of program file: `fill_lists.py`. \diamond

Exercise 5.2. *Fill arrays; loop version.*

The aim is to fill two arrays `x` and `y` with x and $h(x)$ values, respectively, where $h(x)$ is defined in (5.15). Let the x values be as in Exercise 5.1. Create empty arrays `x` and `y` arrays and compute each element in `x` and `y` with a `for` loop. Name of program file: `fill_arrays_loop.py`. \diamond

Exercise 5.3. *Fill arrays; vectorized version.*

Vectorize the code in Exercise 5.2 by creating the x values using the `linspace` function from the `numpy` package and by evaluating $h(x)$ for an array argument. Name of program file: `fill_arrays_vectorized.py`. \diamond

Exercise 5.4. *Plot a function.*

Make a plot of the function in Exercise 5.1 for $x \in [-4, 4]$. Name of program file: `plot_Gaussian.py`. \diamond

Exercise 5.5. *Apply a function to a vector.*

Given a vector $v = (2, 3, -1)$ and a function $f(x) = x^3 + xe^x + 1$, apply f to each element in v . Then calculate $f(v)$ as $v^3 + v * e^v + 1$ using vector computing rules. Show that the two results are equal. \diamond

Exercise 5.6. *Simulate by hand a vectorized expression.*

Suppose x and t are two arrays of the same length, entering a vectorized expression

```
y = cos(sin(x)) + exp(1/t)
```

If x holds two elements, 0 and 2, and t holds the elements 1 and 1.5, calculate by hand (using a calculator) the y array. Thereafter, write a program that mimics the series of computations you did by hand (typically a sequence of operations of the kind we listed on page 192 – use explicit loops, but at the end you can use Numerical Python functionality to check the results). Name of program file: `simulate_vector_computing.py`. \diamond

Exercise 5.7. *Demonstrate array slicing.*

Create an array w with values 0, 0.1, 0.2, ..., 3. Write out $w[:]$, $w[:-2]$, $w[:5]$, $w[2:-2:6]$. Convince yourself in each case that you understand which elements of the array that are printed. Name of program file: `slicing.py`. \diamond

Exercise 5.8. *Replace list operations by array computing.*

The data analysis problem in Chapter 2.6.2 is solved by list operations. Convert the list to a two-dimensional array and perform the three tasks using array operations. There should be no explicit loops in this Python program. Name of program file: `sun_data_vec.py`. \diamond

Exercise 5.9. *Plot a formula.*

Make a plot of the function $y(t) = v_0t - 0.5gt^2$ for $v_0 = 10$, $g = 9.81$, and $t \in [0, 2v_0/g]$. The label on the x axis should be ‘time (s)’ and the label on the y axis should be ‘height (m)’. Name of program file: `plot_ball1.py`. \diamond

Exercise 5.10. *Plot a formula for several parameters.*

Make a program that reads a set of v_0 values from the command line and plots the corresponding curves $y(t) = v_0t - 0.5gt^2$ in the same figure (set $g = 9.81$). Let $t \in [0, 2v_0/g]$ for each curve, which implies that you need a different vector of t coordinates for each curve. Name of program file: `plot_ball2.py`. \diamond

Exercise 5.11. *Specify the x and y axes in Exer. 5.10.*

Extend the program from Exercises 5.10 such that the minimum and maximum x and y values are computed, and use the extreme values to specify the extent of the x and y axes. Add some space above the highest curve. Name of program file: `plot_ball3.py`. \diamond

Exercise 5.12. *Plot exact and inexact Fahrenheit–Celsius formulas.*

Exercise 2.2 introduces a simple rule to quickly compute the Celsius temperature from the Fahrenheit degrees: $C = (F - 30)/2$. Compare this curve against the exact curve $C = (F - 32)5/9$ in a plot. Let F vary between -20 and 120 . Name of program file: `f2c_shortcut_plot.py`. \diamond

Exercise 5.13. *Plot the trajectory of a ball.*

The formula for the trajectory of a ball is given in (1.5) on page 39. In a program, first read the input data y_0 , θ , and v_0 from the command line. Then plot the trajectory $y = f(x)$ for $y \geq 0$. Name of program file: `plot_trajectory.py`. \diamond

Exercise 5.14. *Implement Lagrange’s interpolation formula.*

Imagine we have $n+1$ measurements of some quantity y that depends on x : $(x_0, y_0), (x_1, y_1), \dots, (x_n, y_n)$. We may think of y as a function of x and ask what y is at some arbitrary point x not coinciding with any of the points x_0, \dots, x_n . This problem is known as *interpolation*. One way to solve this problem is to fit a continuous function that goes through all the $n + 1$ points and then evaluate this function for any desired x . A candidate for such a function is the polynomial of degree n that goes through all the points. This polynomial can be written

$$p_L(x) = \sum_{k=0}^n y_k L_k(x), \quad (5.16)$$

where

$$L_k(x) = \prod_{i=0, i \neq k}^n \frac{x - x_i}{x_k - x_i}. \quad (5.17)$$

The \prod notation corresponds to \sum , but the terms are multiplied. For example,

$$\prod_{i=0, i \neq k}^n x_i = x_0 x_1 \cdots x_{k-1} x_{k+1} \cdots x_n.$$

The polynomial $p_L(x)$ is known as Lagrange’s interpolation formula, and the points $(x_0, y_0), \dots, (x_n, y_n)$ are called interpolation points.

Make functions `p_L(x, xp, yp)` and `L_k(x, k, xp, yp)` that evaluate $p_L(x)$ and $L_k(x)$ by (5.16) and (5.17), respectively, at the point x . The arrays `xp` and `yp` contain the x and y coordinates of the $n + 1$ interpolation points, respectively. That is, `xp` holds x_0, \dots, x_n , and `yp` holds y_0, \dots, y_n .

To verify the program, we observe that $L_k(x_k) = 1$ and that $L_k(x_i) = 0$ for $i \neq k$, implying that $p_L(x_k) = y_k$. That is, the polynomial p_L goes through all the points $(x_0, y_0), \dots, (x_n, y_n)$. Write a function `verify(xp, yp)` that computes $|p_L(x_k) - y_k|$ at all the interpolation points (x_k, y_k) and checks that the value is approximately zero. Call `verify` with `xp` and `yp` corresponding to 5 equally spaced

points along the curve $y = \sin(x)$ for $x \in [0, \pi]$. Thereafter, evaluate $p_L(x)$ for an x in the middle of two interpolation points and compare the value of $p_L(x)$ with the exact one, $\sin(x)$. Name of program file: `Lagrange_poly1.py`. \diamond

Exercise 5.15. *Plot the polynomial in Exer. 5.14.*

Write a function `graph(f, n, xmin, xmax, resolution=1001)` for plotting $p_L(x)$ in Exercise 5.14, based on interpolation points taken from some mathematical function $f(x)$ represented by the argument `f`. The argument `n` denotes the number of interpolation points sampled from the $f(x)$ function, and `resolution` is the number of points between `xmin` and `xmax` used to plot $p_L(x)$. The x coordinates of the `n` interpolation points can be uniformly distributed between `xmin` and `xmax`. In the graph, the interpolation points $(x_0, y_0), \dots, (x_n, y_n)$ should be marked by small circles. Test the `graph` function by choosing 5 points in $[0, \pi]$ and `f` as $\sin x$.

Make a module `Lagrange_poly2` containing the `p_L`, `L_k`, `verify`, and `graph` functions. The call to `verify` described in Exercise 5.14 and the call to `graph` described above should appear in the module's test block. Name of program file: `Lagrange_poly2.py`. \diamond

Exercise 5.16. *Investigate the polynomial in Exer. 5.14.*

Unfortunately, the polynomial $p_L(x)$ defined and implemented in Exercise 5.14 can exhibit some undesired oscillatory behavior which we shall explore graphically in this exercise. Compute $n + 1$ interpolation points taken from the curve $f(x) = |x|$ for $x \in [-2, 2]$: $x_k = -2 + 4k/n$ and $y_k = |x_k|$, $k = 0, 1, \dots, n$. Call the `graph` function from Exercise 5.15. for $n = 2, 4, 6, 10$. All the graphs of $p_L(x)$ should appear in the same plot for comparison. In addition, make a new figure with calls to `graph` for $n = 13$ and $n = 20$. All the calls to `graph` should appear in some separate program file which imports the `Lagrange_poly2` module made in Exercise 5.15.

The purpose of the $p_L(x)$ function is to compute (x, y) between some given (often measured) data points $(x_0, y_0), \dots, (x_n, y_n)$. We see from the graphs that for a small number of interpolation points, $p_L(x)$ is quite close to the curve $y = |x|$ we used to generate the data points, but as n increases, $p_L(x)$ starts to oscillate, especially toward the end points (x_0, y_0) and (x_n, y_n) . Much research has historically been focused on methods that do not result in such strange oscillations when fitting a polynomial to a set of points. Name of program file: `Lagrange_poly2b.py`. \diamond

Exercise 5.17. *Plot a wave packet.*

The function

$$f(x, t) = e^{-(x-3t)^2} \sin(3\pi(x-t)) \quad (5.18)$$

describes for a fixed value of t a wave localized in space. Make a program that visualizes this function as a function of x on the interval $[-4, 4]$ when $t = 0$. Name of program file: `plot_wavpacket.py`. \diamond

Exercise 5.18. *Judge a plot.*

Assume you have the following program for plotting a parabola:

```
import numpy as np
x = np.linspace(0, 2, 20)
y = x*(2 - x)
import matplotlib.pyplot as plt
plt.plot(x, y)
plt.show()
```

Then you switch to the function $\cos(18\pi x)$ by altering the computation of y to $y = \cos(18*\pi*x)$. Judge the resulting plot. Is it correct? Display the $\cos(18\pi x)$ function with 1000 points in the same plot. Name of program file: `judge_plot.py`. \diamond

Exercise 5.19. *Plot the viscosity of water.*

The viscosity of water, μ , varies with the temperature T (in Kelvin) according to

$$\mu(T) = A \cdot 10^{B/(T-C)}, \quad (5.19)$$

where $A = 2.414 \cdot 10^{-5}$ Pa s, $B = 247.8$ K, and $C = 140$ K. Plot $\mu(T)$ for T between 0 and 100 degrees Celsius. Label the x axis with ‘temperature (C)’ and the y axis with ‘viscosity (Pa s)’. Note that T in the formula for μ must be in Kelvin. Name of program file: `water_viscosity.py`. \diamond

Exercise 5.20. *Explore a complicated function graphically.*

The wave speed c of water surface waves depends on the length λ of the waves. The following formula relates c to λ :

$$c(\lambda) = \sqrt{\frac{g\lambda}{2\pi} \left(1 + s \frac{4\pi^2}{\rho g \lambda^2} \right) \tanh\left(\frac{2\pi h}{\lambda}\right)}. \quad (5.20)$$

Here, g is the acceleration of gravity (981 cm/s), s is the air-water surface tension ($7.9 \cdot 10^{-4}$ N/cm), ρ is the density of water (can be taken as 1 kg/cm^3), and h is the water depth in cm. Let us fix h at 5000 cm. First make a plot of $c(\lambda)$ (in cm/s) for small λ (0.1 cm to 10 cm). Then make a plot $c(\lambda)$ for larger λ (1 m to 2 km, but converted to cm since this cm is the length scale in the values for ρ , s , and g). Name of program file: `water_wave_velocity.py`. \diamond

Exercise 5.21. *Plot Taylor polynomial approximations to $\sin x$.*

The sine function can be approximated by a polynomial according to the following formula:

$$\sin x \approx S(x; n) = \sum_{j=0}^n (-1)^j \frac{x^{2j+1}}{(2j+1)!}. \quad (5.21)$$

The expression $(2j + 1)!$ is the factorial (see Exercise 3.19). The error in the approximation $S(x; n)$ decreases as n increases and in the limit we have that $\lim_{n \rightarrow \infty} S(x; n) = \sin x$. The purpose of this exercise is to visualize the quality of various approximations $S(x; n)$ as n increases.

The first part of the exercise is to write a Python function `S(x, n)` that computes $S(x; n)$. Use a straightforward approach where you compute each term as it stands in the formula, i.e., $(-1)^j x^{2j+1}$ divided by the factorial $(2j + 1)!$. (We remark that Exercise A.18 outlines a much more efficient computation of the terms in the series.)

The next part of the exercise is to plot $\sin x$ on $[0, 4\pi]$ together with the approximations $S(x; 1)$, $S(x; 2)$, $S(x; 3)$, $S(x; 6)$, and $S(x; 12)$. Name of program file: `plot_Taylor_sin.py`. \diamond

Exercise 5.22. *Animate a wave packet.*

Display an animation of the function $f(x, t)$ in Exercise 5.17 by plotting f as a function of x on $[-6, 6]$ for a set of t values in $[-1, 1]$. Also make an animated GIF file. A suitable resolution can be 1000 intervals (1001 points) along the x axis, 60 intervals (61 points) in time, and 6 frames per second in the animated GIF file. Use the recipe in Chapter 5.3.4 and remember to remove the family of old plot files in the beginning of the program. Name of program file: `plot_wavpacket_movie.py`. \diamond

Exercise 5.23. *Animate a smoothed Heaviside function.*

Visualize the smoothed Heaviside function $H_\epsilon(x)$, defined in (3.26) on page 128, as an animation where ϵ starts at 2 and then goes to zero. Name of program file: `smoothed_Heaviside_movie.py`. \diamond

Exercise 5.24. *Animate two-scale temperature variations.*

We consider temperature oscillations in the ground as addressed in Chapter 5.8.2. Now we want to visualize daily and annual variations. Let A_1 be the amplitude of annual variations and A_2 the amplitude of the day/night variations. Let also $P_1 = 365$ days and $P_2 = 24$ h be the periods of the annual and the daily oscillations. The temperature at time t and depth z is then given by¹⁶

$$T(z, t) = T_0 + A_1 e^{-a_1 z} \sin(\omega_1 t - a_1 z) + A_2 e^{-a_2 z} \sin(\omega_2 t - a_2 z), \quad (5.22)$$

where

$$\begin{aligned} \omega_1 &= 2\pi P_1, \\ \omega_2 &= 2\pi P_2, \end{aligned}$$

¹⁶ Here we assume that the temperature T equals the reference temperature T_0 at $t = 0$, resulting in a sine variation rather than the cosine variation in (5.13).

$$a_1 = \sqrt{\frac{\omega_1}{2k}},$$

$$a_2 = \sqrt{\frac{\omega_2}{2k}}.$$

Choose $k = 10^{-6}$ m²/s, $A_1 = 15$ C, $A_2 = 7$ C, and the resolution Δt as $P_2/10$. Modify the `heatwave.py` program in order to animate this new temperature function. Name of program file: `heatwave2.py`. \diamond

Exercise 5.25. *Improve the solution in Exer. 5.24.*

Watching the animation in Exercise 5.24 reveals that there are rapid oscillations in a small layer close to $z = 0$. The variations away from $z = 0$ are much smaller in time and space. It would therefore be wise to use more z coordinates close to $z = 0$ than for larger z values. Given a set $x_0 < x_1 < \dots < x_n$ of uniformly spaced coordinates in $[a, b]$, we can compute new coordinates \bar{x}_i , stretched toward $x = a$, by the formula

$$\bar{x}_i = a + (b - a) \left(\frac{x_i - a}{b - a} \right)^s,$$

for some $s > 1$. Use this formula to stretch the z coordinates to the left. Experiment with $s \in [1.2, 3]$ and few points (say 15) and visualize the curve as a line with circles at the points so that you can easily see the distribution of points toward the left end. Run the animation with no circles and (say) 501 points when a suitable s has been found.

We say that the new z coordinates are *adapted* to the curve, meaning that we have distributed the z coordinates where we need them most, i.e., where there are rapid variations of the curve. Name of program file: `heatwave2a.py`. \diamond

Exercise 5.26. *Animate a sequence of approximations to π .*

Exercise 3.11 outlines an idea for approximating π as the length of a polygon inside the circle. Wrap the code from Exercise 3.11 in a function `pi_approx(N)` which returns the approximation to π using a polygon with $N + 1$ equally distributed points. The task of the present exercise is to visually display the polygons as a movie, where each frame shows the polygon with $N + 1$ points together with the circle and a title reflecting the corresponding error in the approximate value of π . The whole movie arises from letting N run through $4, 5, 6, \dots, K$, where K is some (large) prescribed value. Let there be a pause of 0.3 s between each frame in the movie. By playing the movie you will see how the polygons move closer and closer to the circle and how the approximation to π improves. Name of program file: `pi_polygon_movie.py`. \diamond

Exercise 5.27. *Animate a planet's orbit.*

A planet's orbit around a star has the shape of an ellipse. The purpose of this exercise is to make an animation of the movement along

the orbit. One should see a small disk, representing the planet, moving along an elliptic curve. An evolving solid line shows the development of the planet's orbit as the planet moves.

The points (x, y) along the ellipse are given by the expressions

$$x = a \cos(\omega t), \quad y = b \sin(\omega t),$$

where a is the semimajor axis of the ellipse, b is the semiminor axis, ω is an angular velocity of the planet around the star, and t denotes time. One complete orbit corresponds to $t \in [0, 2\pi/\omega]$. Let us discretize time into time points $t_k = k\Delta t$, where $\Delta t = 2\pi/(\omega n)$. Each frame in the movie corresponds to (x, y) points along the curve with t values t_0, t_1, \dots, t_i , i representing the frame number ($i = 1, \dots, n$). Let the plot title of each frame display the planet's instantaneous velocity magnitude. This magnitude is the length of the velocity vector

$$\left(\frac{dx}{dt}, \frac{dy}{dt} \right) = (-\omega a \sin(\omega t), \omega b \cos(\omega t)),$$

which becomes $\omega \sqrt{a^2 \sin^2(\omega t) + b^2 \cos^2(\omega t)}$.

Implement the visualization of the planet's orbit using the method above. Run the special case of a circle and verify that the magnitude of the velocity remains constant as the planet moves. Name of program file: `planet_orbit.py`. \diamond

Exercise 5.28. *Animate the evolution of Taylor polynomials.*

A general series approximation (to a function) can be written as

$$S(x; M, N) = \sum_{k=M}^N f_k(x).$$

For example, the Taylor polynomial of degree N for e^x equals $S(x; 0, N)$ with $f_k(x) = x^k/k!$. The purpose of the exercise is to make a movie of how $S(x; M, N)$ develops (and hopefully improves as an approximation) as we add terms in the sum. That is, the frames in the movie correspond to plots of $S(x; M, M)$, $S(x; M, M+1)$, $S(x; M, M+2)$, \dots , $S(x; M, N)$.

Make a function

```
animate_series(fk, M, N, xmin, xmax, ymin, ymax, n, exact)
```

for creating such animations. The argument `fk` holds a Python function implementing the term $f_k(x)$ in the sum, `M` and `N` are the summation limits, the next arguments are the minimum and maximum x and y values in the plot, `n` is the number of x points in the curves to be plotted, and `exact` holds the function that $S(x)$ aims at approximating.

Here is some more information on how to write the `animate_series` function. The function must accumulate the $f_k(x)$ terms in a variable s , and for each k value, s is plotted against x together with a curve

reflecting the exact function. Each plot must be saved in a file, say with names `tmp_0000.png`, `tmp_0001.png`, and so on (these filenames can be generated by `tmp_%04d.png`, using an appropriate counter). Use the `movie` function to combine all the plot files into a movie in a desired movie format.

In the beginning of the `animate_series` function, it is necessary to remove all old plot files of the form `tmp_*.png`. This can be done by the `glob` module and the `os.remove` function as exemplified in Chapter 5.3.4.

Test the `animate_series` function in two cases:

1. The Taylor series for $\sin x$, where $f_k(x) = (-1)^k x^{2k+1}/(2k+1)!$, and $x \in [0, 13\pi]$, $M = 0$, $N = 40$, $y \in [-2, 2]$.
2. The Taylor series for e^{-x} , where $f_k(x) = (-x)^k/k!$, and $x \in [0, 15]$, $M = 0$, $N = 30$, $y \in [-0.5, 1.4]$.

Name of program file: `animate_Taylor_series.py`. ◇

Exercise 5.29. *Plot the velocity profile for pipeflow.*

A fluid that flows through a (very long) pipe has zero velocity on the pipe wall and a maximum velocity along the centerline of the pipe. The velocity v varies through the pipe cross section according to the following formula:

$$v(r) = \left(\frac{\beta}{2\mu_0}\right)^{1/n} \frac{n}{n+1} (R^{1+1/n} - r^{1+1/n}), \quad (5.23)$$

where R is the radius of the pipe, β is the pressure gradient (the force that drives the flow through the pipe), μ_0 is a viscosity coefficient (small for air, larger for water and even larger for toothpaste), n is a real number reflecting the viscous properties of the fluid ($n = 1$ for water and air, $n < 1$ for many modern plastic materials), and r is a radial coordinate that measures the distance from the centerline ($r = 0$ is the centerline, $r = R$ is the pipe wall).

Make a function that evaluates $v(r)$. Plot $v(r)$ as a function of $r \in [0, R]$, with $R = 1$, $\beta = 0.02$, $\mu = 0.02$, and $n = 0.1$. Thereafter, make an animation of how the $v(r)$ curves varies as n goes from 1 and down to 0.01. Because the maximum value of $v(r)$ decreases rapidly as n decreases, each curve can be normalized by its $v(0)$ value such that the maximum value is always unity. Name of program file: `plot_velocity_pipeflow.py`. ◇

Exercise 5.30. *Plot the functions from Exer. 3.13.*

Exercise 3.13 defines the approximation $S(t; n)$ to a function $f(t)$. Plot $S(t; 1)$, $S(t; 3)$, $S(t; 20)$, $S(t; 200)$, and the exact $f(t)$ function in the same plot. Use $T = 2\pi$. Name of program file: `sinesum1_plot.py`. ◇

Exercise 5.31. *Make a movie of the functions from Exer. 3.13.*

First perform Exercise 5.30. A natural next step is to animate the evolution of $S(t; n)$ as n increases. Create such an animation and observe how the discontinuity in $f(t)$ is poorly approximated by $S(t; n)$, even when n grows large (plot $f(t)$ in each frame). This is a well-known deficiency, called Gibbs's phenomenon, when approximating discontinuous functions by sine or cosine (Fourier) series. Name of program file: `sinesum1_movie.py`. \diamond

Exercise 5.32. *Plot functions from the command line.*

For quickly getting a plot a function $f(x)$ for $x \in [x_{\min}, x_{\max}]$ it could be nice to have a program that takes the minimum amount of information from the command line and produces a plot on the screen and saves the plot to a file `tmp.png`. The usage of the program goes as follows:

```
Terminal
plotf.py "f(x)" xmin xmax
```

A specific example is

```
Terminal
plotf.py "exp(-0.2*x)*sin(2*pi*x)" 0 4*pi
```

Hint: Make x coordinates from the second and third command-line arguments and then use `eval` (or `StringFunction` from Chapters 4.1.4 and 5.5.1) on the first argument. Try to write as short program as possible (we leave it to Exercise 5.33 to test for valid input). Name of program file: `plotf_v1.py`. \diamond

Exercise 5.33. *Improve the program from Exercise 5.32.*

Equip the program from Exercise 5.32 with tests on valid input on the command line. Also allow an optional fourth command-line argument for the number of points along the function curve. Set this number to 501 if it is not given. Name of program file: `plotf.py`. \diamond

Exercise 5.34. *Demonstrate energy concepts from physics.*

The vertical position $y(t)$ of a ball thrown upward is given by $y(t) = v_0 t - 0.5gt^2$, where g is the acceleration of gravity and v_0 is the velocity at $t = 0$. Two important physical quantities in this context are the potential energy, obtained by doing work against gravity, and the kinetic energy, arising from motion. The potential energy is defined as $P = mgy$, where m is the mass of the ball. The kinetic energy is defined as $K = \frac{1}{2}mv^2$, where v is the velocity of the ball, related to y by $v(t) = y'(t)$. Plot $P(t)$ and $K(t)$ in the same plot, along with their sum $P + K$. Let $t \in [0, 2v_0/g]$. Read m and v_0 from the command line. Run the program with various choices of m and v_0 and observe that $P + K$ is always constant in this motion. In fact, it turns out that $P + K$

is constant for a large class of motions, and this is a very important result in physics. Name of program file: `energy_physics.py`. ◇

Exercise 5.35. *Plot a w-like function.*

Define mathematically a function that looks like the ‘w’ character. Plot this function. Name of program file: `plot_w.py`. ◇

Exercise 5.36. *Plot a piecewise constant function.*

Consider the piecewise constant function defined in Exercise 3.27. Make a Python function `plot_piecewise(data, xmax)` which draws a graph of the function, where `data` is the nested list explained in Exercise 3.27 and `xmax` is the maximum x coordinate. Use ideas from Chapter 5.4.1. Name of program file: `plot_piecewise_constant.py`. ◇

Exercise 5.37. *Vectorize a piecewise constant function.*

Consider the piecewise constant function defined in Exercise 3.27. Make vectorized version implementation. Name of program file: `piecewise_constant_vec.py`. ◇

Exercise 5.38. *Visualize approximations in the Midpoint integration rule.*

Consider the midpoint rule for integration from Exercise 3.8. Use Matplotlib to make an illustration of the midpoint rule as shown in Figure 5.14a. Look up the documentation of the Matplotlib function `fill_between` and use this function to create the filled areas between $f(x)$ and the approximating rectangles. The $f(x)$ function used in Figure 5.14 is

$$f(x) = x(12 - x) + \sin(\pi x), \quad x \in [0, 10].$$

Note that the `fill_between` requires the two curves to have the same number of points. For accurate visualization of $f(x)$ you need quite many x coordinates, and the rectangular approximation to $f(x)$ must be drawn using the same set of x coordinates. Name of program file: `viz_midpoint.py`. ◇

Exercise 5.39. *Visualize approximations in the Trapezoidal integration rule.*

Redo Exercise 5.38 for the Trapezoidal rule from Exercise 3.7 to produce the graph shown in Figure 5.14b. Name of program file: `viz_trapezoidal.py`. ◇

Exercise 5.40. *Experience overflow in a function.*

When an object (ball, car, airplane) moves through the air, there is a very, very thin layer of air close to the object’s surface where the air velocity varies dramatically¹⁷, from the same value as the velocity of

¹⁷ This layer is called a *boundary layer*. The physics in the boundary layer is very important for air resistance and cooling/heating of objects.

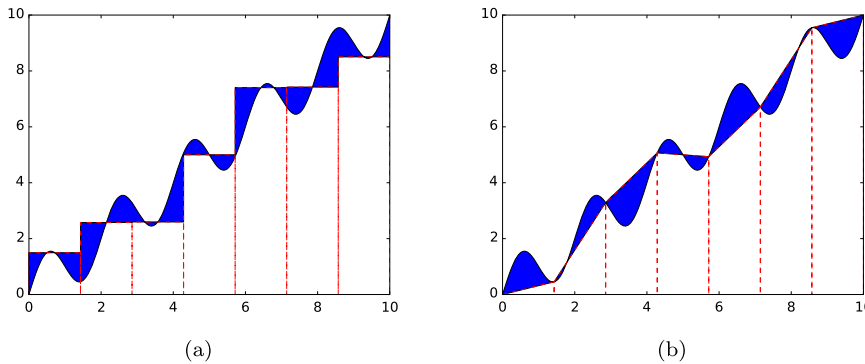

Fig. 5.14 Visualization of numerical integration rules: (a) the Midpoint rule; (b) the Trapezoidal rule. The filled areas illustrate the errors in the approximation of the area under the curve.

the object at the object’s surface to zero a few centimeters away. The change in velocity is quite abrupt and can be modeled by the function

$$v(x) = \frac{1 - e^{x/\mu}}{1 - e^{1/\mu}},$$

where $x = 1$ is the object’s surface, and $x = 0$ is some distance away where one cannot notice any wind velocity v because of the passing object ($v = 0$). The wind velocity coincides with the velocity of the object at $x = 1$, here set to $v = 1$. The parameter μ is very small and related to the viscosity of air. With a small value of μ , it becomes difficult to calculate $v(x)$ on a computer.

Make a function `v(x, mu=1E-6, exp=math.exp)` for calculating the formula for $v(x)$ using `exp` as a possibly user-given exponential function. Let the `v` function return the nominator and denominator in the formula as well as the fraction (result). Call the `v` function for various `x` values between 0 and 1 in a `for` loop, let `mu` be `1E-3`, and have an inner `for` loop over two different `exp` functions: `math.exp` and `numpy.exp`. The output will demonstrate how the denominator is subject to overflow and how difficult it is to calculate this function on a computer.

Also plot $v(x)$ for $\mu = 1, 0.01, 0.001$ on $[0, 1]$ using 10,000 points to see what the function looks like. Name of program file: `boundary_layer_func1.py`. \diamond

Exercise 5.41. *Experience less overflow in a function.*

In the program from Exercise 5.40, convert `x` and `eps` to a higher precision representation of real numbers, with the aid of the NumPy type `float96`:

```
import numpy
x = numpy.float96(x); mu = numpy.float96(e)
```

Call the `v` function with these type of variables observe how much “better” results we get with `float96` compared the standard `float` value

(which is `float64` – the number reflects the number of bits in the machine’s representation of a real number). Also call the `v` function with `x` and `mu` as `float32` variables and report how the function now behaves. Name of program file: `boundary_layer_func2.py`. \diamond

Exercise 5.42. *Extend Exer. 5.5 to a rank 2 array.*

Let A be the two-dimensional array

$$\begin{bmatrix} 0 & 12 & -1 \\ -1 & -1 & -1 \\ 11 & 5 & 5 \end{bmatrix}$$

Apply the function f from Exercise 5.5 to each element in A . Then calculate the result of the array expression $A * 3 + A * e^A + 1$, and demonstrate that the end result of the two methods are the same. \diamond

Exercise 5.43. *Explain why array computations fail.*

The following loop computes the array y from x :

```
>>> import numpy as np
>>> x = np.linspace(0, 1, 3)
>>> y = np.zeros(len(x))
>>> for i in range(len(x)):
...     y[i] = x[i] + 4
```

However, the alternative loop

```
>>> for xi, yi in zip(x, y):
...     yi = xi + 5
```

leaves y unchanged. Why? Explain in detail what happens in each pass of this loop and write down the contents of x_i , y_i , x , and y as the loop progresses. \diamond

Files are used for permanent storage of information on a computer. From previous computer experience you are hopefully used to save information to files and open the files at a later time for inspection again. The present chapter tells you how Python programs can access information in files (Chapter 6.1) and also create new files (Chapter 6.5). The chapter builds on programming concepts introduced in Chapters 1–5.

Since files often contain structured information that one wants to map to objects in a running program, there is a need for flexible objects where various kinds of other objects can be stored. Dictionaries are very handy for this purpose and are described in Chapter 6.2.

Information in files often appear as pure text, so to interpret and extract data from files it is sometimes necessary to carry out sophisticated operations on the text. Python strings have many methods for performing such operations, and the most important functionality is described in Chapter 6.3.

The World Wide Web is full of information and scientific data that may be useful to access from a program. Chapter 6.4 tells you how to read web pages from a program and interpret the contents using string operations.

The folder `src/files` contains all the program example files referred to in the present chapter.

6.1 Reading Data from File

Suppose we have recorded some measurements in a file `data1.txt`, located in the `src/files` folder. The goal of our first example of reading files is to read the measurement values in `data1.txt`, find the average value, and print it out in the terminal window.

Before trying to let a program read a file, we must know the *file format*, i.e., what the contents of the file looks like, because the structure of the text in the file greatly influences the set of statements needed to read the file. We therefore start with viewing the contents of the file `data1.txt`. To this end, load the file into a text editor or viewer¹. What we see is a column with numbers:

```
21.8
18.1
19
23
26
17.8
```

Our task is to read this column of numbers into a list in the program and compute the average of the list items.

6.1.1 Reading a File Line by Line

To read a file, we first need to *open* the file. This action creates a file object, here stored in the variable `infile`:

```
infile = open('data1.txt', 'r')
```

The second argument to the `open` function, the string `'r'`, tells that we want to open the file for reading. We shall later see that a file can be opened for writing instead, by providing `'w'` as the second argument. After the file is read, one should close the file object with `infile.close()`.

For Loop over Lines. We can read the contents of the file in various ways. The basic recipe for reading the file line by line applies a `for` loop like this:

```
for line in infile:
    # do something with line
```

The `line` variable is a string holding the current line in the file. The `for` loop over lines in a file has the same syntax as when we go through a list. Just think of the file object `infile` as a collection of elements, here lines in a file, and the `for` loop visits these elements in sequence such that the `line` variable refers to one line at a time. If something seemingly goes wrong in such a loop over lines in a file, it is useful to do a `print line` inside the loop.

Instead of reading one line at a time, we can load all lines into a list of strings (lines) by

¹ You can use `emacs`, `vim`, `more`, or `less` on Unix and Mac. On Windows, `WordPad` is appropriate, or the `type` command in a DOS window. Word processors such as OpenOffice or Microsoft Word can also be used.

```
lines = infile.readlines()
```

This statement is equivalent to

```
lines = []
for line in infile:
    lines.append(line)
```

or the list comprehension:

```
lines = [line for line in infile]
```

In the present example, we load the file into the list `lines`. The next task is to compute the average of the numbers in the file. Trying a straightforward sum of all numbers on all lines,

```
mean = 0
for number in lines:
    mean = mean + number
mean = mean/len(lines)
```

gives an error message:

```
TypeError: unsupported operand type(s) for +: 'int' and 'str'
```

The reason is that `lines` holds each line (`number`) as a string, not a float or int that we can add to other numbers. A fix is to convert each line to a float:

```
mean = 0
for line in lines:
    number = float(line)
    mean = mean + number
mean = mean/len(lines)
```

This code snippet works fine. The complete code can be found in the file `files/mean1.py`.

Summing up a list of numbers is often done in numerical programs, so Python has a special function `sum` for performing this task. However, `sum` must in the present case operate on a list of floats, not strings. We can use a list comprehension to turn all elements in `lines` into corresponding float objects:

```
mean = sum([float(line) for line in lines])/len(lines)
```

An alternative implementation is to load the lines into a list of float objects directly. Using this strategy, the complete program (found in file `mean2.py`) takes the form

```
infile = open('data1.txt', 'r')
numbers = [float(line) for line in infile.readlines()]
infile.close()
mean = sum(numbers)/len(numbers)
print mean
```

A newcomer to programming might find it confusing to see that one problem is solved by many alternative sets of statements, but this is the very nature of programming. A clever programmer will judge several alternative solutions to a programming task and choose one that is either particularly compact, easy to understand, and/or easy to extend later. We therefore present more examples on how to read the `data1.txt` file and compute with the data.

While Loop over Lines. The call `infile.readline()` returns a string containing the text at the current line. A new `infile.readline()` will read the next line. When `infile.readline()` returns an empty string, the end of the file is reached and we must stop further reading. The following `while` loop reads the file line by line using `infile.readline()`:

```
while True:
    line = infile.readline()
    if not line:
        break
    # process line
```

This is perhaps a somewhat strange loop, but it is a well-established way of reading a file in Python (especially in older codes). The shown `while` loop runs forever since the condition is always `True`. However, inside the loop we test if `line` is `False`, and it is `False` when we reach the end of the file, because `line` then becomes an empty string, which in Python evaluates to `False`. When `line` is `False`, the `break` statement breaks the loop and makes the program flow jump to the first statement after the `while` block.

Computing the average of the numbers in the `data1.txt` file can now be done in yet another way:

```
infile = open('data1.txt', 'r')
mean = 0
n = 0
while True:
    line = infile.readline()
    if not line:
        break
    mean += float(line)
    n += 1
mean = mean/float(n)
```

Reading a File into a String. The call `infile.read()` reads the whole file and returns the text as a string object. The following interactive session illustrates the use and result of `infile.read()`:

```
>>> infile = open('data1.txt', 'r')
>>> filestr = infile.read()
>>> filestr
'21.8\n18.1\n19\n23\n26\n17.8\n'
>>> print filestr
21.8
18.1
```

```
19
23
26
17.8
```

Note the difference between just writing `filestr` and writing `print filestr`. The former dumps the string with newlines as “backslash n” characters, while the latter is a “pretty print” where the string is written out without quotes and with the newline characters as visible line shifts².

Having the numbers inside a string instead of inside a file does not look like a major step forward. However, string objects have many useful functions for extracting information. A very useful feature is *split*: `filestr.split()` will split the string into words (separated by blanks or any other sequence of characters you have defined). The “words” in this file are the numbers:

```
>>> words = filestr.split()
>>> words
['21.8', '18.1', '19', '23', '26', '17.8']
>>> numbers = [float(w) for w in words]
>>> mean = sum(numbers)/len(numbers)
>>> print mean
20.95
```

A more compact program looks as follows (`mean3.py`):

```
infile = open('data1.txt', 'r')
numbers = [float(w) for w in infile.read().split()]
mean = sum(numbers)/len(numbers)
```

The next section tells you more about splitting strings.

6.1.2 Reading a Mixture of Text and Numbers

The `data1.txt` file has a very simple structure since it contains numbers only. Many data files contain a mix of text and numbers. The file `rainfall.dat` provides an example³:

```
Average rainfall (in mm) in Rome: 1188 months between 1782 and 1970
Jan 81.2
Feb 63.2
Mar 70.3
Apr 55.7
May 53.0
Jun 36.4
Jul 17.5
Aug 27.5
Sep 60.9
Oct 117.7
Nov 111.0
Dec 97.9
Year 792.9
```

² The difference between these two outputs is explained in Chapter 7.3.9.

³ <http://www.worldclimate.com/cgi-bin/data.pl?ref=N41E012+2100+1623501G1>

How can we read the rainfall data in this file and make a plot of the values?

The most straightforward solution is to read the file line by line, and for each line split the line into words, pick out the last (second) word on the line, convert this word to `float`, and store the `float` objects in a list. Having the rainfall values in a list of real numbers, we can make a plot of the values versus the month number. The complete code, wrapped in a function, may look like this (file `rainfall.py`):

```
def extract_data(filename):
    infile = open(filename, 'r')
    infile.readline() # skip the first line
    numbers = []
    for line in infile:
        words = line.split()
        number = float(words[1])
        numbers.append(number)
    infile.close()
    return numbers

values = extract_data('rainfall.dat')
from scitools.std import plot
month_indices = range(1, 13)
plot(month_indices, values[:-1], 'o2')
```

Note that the first line in the file is just a comment line and of no interest to us. We therefore read this line by `infile.readline()`. The for loop over the lines in the file will then start from the next (second) line.

Also note that `numbers` contain data for the 12 months plus the average annual rainfall. We want to plot the average rainfall for the months only, i.e., `values[0:12]` or simply `values[:-1]` (everything except the last entry). Along the “x” axis we put the index of a month, starting with 1. A call to `range(1,13)` generates these indices.

We can condense the for loop over lines in the file, if desired, by using a list comprehension:

```
def extract_data(filename):
    infile = open(filename, 'r')
    infile.readline() # skip the first line
    numbers = [float(line.split()[1]) for line in infile]
    infile.close()
    return numbers
```

6.1.3 What Is a File, Really?

This section is not mandatory for understanding the rest of the book. However, we think the information here is fundamental for understanding what files are about.

A file is simply a sequence of characters. In addition to the sequence of characters, a file has some data associated with it, typically the name of the file, its location on the disk, and the file size. These data

are stored somewhere by the operating system. Without this extra information beyond the pure file contents as a sequence of characters, the operating system cannot find a file with a given name on the disk.

Each character in the file is represented as a *byte*, consisting of eight *bits*. Each bit is either 0 or 1. The zeros and ones in a byte can be combined in $2^8 = 256$ ways. This means that there are 256 different types of characters. Some of these characters can be recognized from the keyboard, but there are also characters that do not have a familiar symbol. The name of such characters looks cryptic when printed.

Pure Text Files. To see that a file is really just a sequence of characters, invoke an editor for plain text, e.g., the editor you use to write Python programs. Write the four characters ABCD into the editor, do not press the Return key, and save the text to a file `test1.txt`. Use your favorite tool for file and folder overview and move to the folder containing the `test1.txt` file. This tool may be Windows Explorer, My Computer, or a DOS window on Windows; a terminal window, Konqueror, or Nautilus on Linux; or a terminal window or Finder on Mac. If you choose a terminal window, use the `cd` (change directory) command to move to the proper folder and write `dir` (Windows) or `ls -l` (Linux/Mac) to list the files and their sizes. In a graphical program like Windows Explorer, Konqueror, Nautilus, or Finder, select a view that shows the *size* of each file⁴. You will see that the `test1.txt` file has a size of 4 bytes⁵. The 4 bytes are exactly the 4 characters ABCD in the file. Physically, the file is just a sequence of 4 bytes on your hard disk.

Go back to the editor again and add a newline by pressing the Return key. Save this new version of the file as `test2.txt`. When you now check the size of the file it has grown to five bytes. The reason is that we added a newline character (symbolically known as “backslash n”).

Instead of examining files via editors and folder viewers we may use Python interactively:

```
>>> file1 = open('test1.txt', 'r').read() # read file into string
>>> file1
'ABCD'
>>> len(file1)          # length of string in bytes/characters
4
>>> file2 = open('test2.txt', 'r').read()
>>> file2
'ABCD\n'
>>> len(file2)
5
```

Python has in fact a function that returns the size of a file directly:

⁴ Choose “view as details” in Windows Explorer, “View as List” in Nautilus, the list view icon in Finder, or you just point at a file icon in Konqueror and watch the pop-up text.

⁵ If you use `ls -l`, the size measured in bytes is found in column 5, right before the date.

```
>>> import os
>>> size = os.path.getsize('test1.txt')
>>> size
4
```

Word Processor Files. Most computer users write text in a word processing program, such as Microsoft Word or OpenOffice. Let us investigate what happens with our four characters ABCD in such a program. Start the word processor, open a new document, and type in the four characters ABCD only. Save the document as a .doc file (Microsoft Word) or an .odt file (OpenOffice). Load this file into an editor for pure text and look at the contents. You will see that there are numerous strange characters that you did not write (!). This additional “text” contains information on what type of document this is, the font you used, etc. The OpenOffice version of this file has 5725 bytes! However, if you save the file as a pure text file, with extension .txt, the size is not more than four bytes, and the text file contains just the corresponding characters ABCD.

Instead of loading the OpenOffice file into an editor we can again read the file contents into a string in Python and examine this string:

```
>>> infile = open('test3.odt', 'r') # open OpenOffice file
>>> s = infile.read()
>>> len(s) # file size
5725
>>> s
'PK\x03\x04\x14\x00\x00\x00\x00\x00r\x80E6~\xc62\x0c\...
\x00\x00mimetypeapplication/vnd.oasis.opendocument.textPK\x00...
\x00\x00content.xml\xa5VMS\xdb0\x10\xbd\x7Wx|\xe8\xcd\x11...'
```

Each backslash followed by x and a number is a code for a special character not found on the keyboard (recall that there are 256 characters and only a subset is associated with keyboard symbols). Although we show just a small portion of all the characters in this file in the above output⁶, we can guarantee that you cannot find the pure sequence of characters ABCD. However, the computer program that generated the file, OpenOffice in this example, can easily interpret the meaning of all the characters in the file and translate the information into nice, readable text on the screen.

Image Files. A digital image – captured by a digital camera or a mobile phone – is a file. And since it is a file, the image is just a sequence of characters. Loading some JPEG file into a pure text editor, you can see all the strange characters in there. On the first line you will (normally) find some recognizable text in between the strange characters. This text reflects the type of camera used to capture the image and the date and time when the picture was taken. The next lines contain

⁶ Otherwise, the output would have occupied several pages in this book with about five thousand backslash-x-number symbols...

more information about the image. Thereafter, the file contains a set of numbers representing the image. The basic representation of an image is a set of $m \times n$ pixels, where each pixel has a color represented as a combination of 256 values of red, green, and blue, which can be stored as three bytes (resulting in 256^3 color values). A 6 megapixel camera will then need to store $3 \times 6 \cdot 10^6 = 18$ megabytes for one picture. The JPEG file contains only a couple of megabytes. The reason is that JPEG is a *compressed* file format, produced by applying a smart technique that can throw away pixel information in the original picture such that the human eye hardly can detect the inferior quality.

A video is just a sequence of images, and therefore a video is also a stream of bytes. If the change from one video frame (image) to the next is small, one can use smart methods to compress the image information in time. Such compression is particularly important for videos since the file sizes soon get too large for being transferred over the Internet. A small video file occasionally has bad visual quality, caused by too much compression.

Music Files. An MP3 file is much like a JPEG file: First, there is some information about the music (artist, title, album, etc.), and then comes the music itself as a stream of bytes. A typical MP3 file has a size of something like five million bytes⁷, i.e., five megabytes (5 Mb). On a 2 Gb MP3 player you can then store roughly $2,000,000,000/5,000,000 = 400$ MP3 files. MP3 is, like JPEG, a compressed format. The complete data of a song on a CD (the WAV file) contains about ten times as many bytes. As for pictures, the idea is that one can throw away a lot of bytes in an intelligent way, such that the human ear hardly detects the difference between a compressed and uncompressed version of the music file.

PDF Files. Looking at a PDF file in a pure text editor shows that the file contains some readable text mixed with some unreadable characters. It is not possible for a human to look at the stream of bytes and deduce the text in the document⁸. A PDF file reader can easily interpret the contents of the file and display the text in a human-readable form on the screen.

Remarks. We have repeated many times that a file is just a stream of bytes. A human can interpret (read) the stream of bytes if it makes sense in a human language – or a computer language (provided the human is a programmer). When the series of bytes does not make

⁷ The exact size depends on the complexity of the music, the length of the track, and the MP3 resolution.

⁸ From the assumption that there are always some strange people doing strange things, there might be somebody out there who – with a lot of training – can interpret the pure PDF code with the eyes.

sense to any human, a computer program must be used to interpret the sequence of characters.

Think of a report. When you write the report as pure text in a text editor, the resulting file contains just the characters you typed in from the keyboard. On the other hand, if you applied a word processor like Microsoft Word or OpenOffice, the report file contains a large number of extra bytes describing properties of the formatting of the text. This stream of extra bytes does not make sense to a human, and a computer program is required to interpret the file content and display it in a form that a human can understand. Behind the sequence of bytes in the file there are strict rules telling what the series of bytes means. These rules reflect the *file format*. When the rules or file format is publicly documented, a programmer can use this documentation to make her own program for interpreting the file contents⁹. It happens, though, that secret file formats are used, which require certain programs from certain companies to interpret the files.

6.2 Dictionaries

So far in the book we have stored information in various types of objects, such as numbers, strings, list, and arrays. A *dictionary* is a very flexible object for storing various kind of information, and in particular when reading files. It is therefore time to introduce the dictionary type.

A list is a collection of objects indexed by an integer going from 0 to the number of elements minus one. Instead of looking up an element through an integer index, it can be more handy to use a text. Roughly speaking, a list where the index can be a text is called a dictionary in Python. Other computer languages use other names for the same thing: HashMap, hash, associative array, or map.

6.2.1 Making Dictionaries

Suppose we need to store the temperatures from three cities: Oslo, London, and Paris. For this purpose we can use a list,

```
temps = [13, 15.4, 17.5]
```

but then we need to remember the sequence of cities, e.g., that index 0 corresponds to Oslo, index 1 to London, and index 2 to Paris. That is, the London temperature is obtained as `temps[1]`. A dictionary with the city name as index is more convenient, because this allows us to

⁹ Interpreting such files is much more complicated than our examples on reading human-readable files in this book.

write `temps['London']` to look up the temperature in London. Such a dictionary is created by one of the following two statements

```
temps = {'Oslo': 13, 'London': 15.4, 'Paris': 17.5}
# or
temps = dict(Oslo=13, London=15.4, Paris=17.5)
```

Additional text-value pairs can be added when desired. We can, for instance, write

```
temps['Madrid'] = 26.0
```

The `temps` dictionary has now four text-value pairs, and a `print temps` yields

```
{'Oslo': 13, 'London': 15.4, 'Paris': 17.5, 'Madrid': 26.0}
```

6.2.2 Dictionary Operations

The string “indices” in a dictionary are called *keys*. To loop over the keys in a dictionary `d`, one writes `for key in d:` and works with `key` and the corresponding value `d[key]` inside the loop. We may apply this technique to write out the temperatures in the `temps` dictionary from the previous paragraph:

```
>>> for city in temps:
...     print 'The temperature in %s is %g' % (city, temps[city])
...
The temperature in Paris is 17.5
The temperature in Oslo is 13
The temperature in London is 15.4
The temperature in Madrid is 26
```

We can check if a key is present in a dictionary by the syntax `if key in d:`

```
>>> if 'Berlin' in temps:
...     print 'Berlin:', temps['Berlin']
... else:
...     print 'No temperature data for Berlin'
...
No temperature data for Berlin
```

Writing `key in d` yields a standard boolean expression, e.g.,

```
>>> 'Oslo' in temps
True
```

The keys and values can be extracted as lists from a dictionary:

```
>>> temps.keys()
['Paris', 'Oslo', 'London', 'Madrid']
>>> temps.values()
[17.5, 13, 15.4, 26.0]
```

An important feature of the `keys` method in dictionaries is that the order of the returned list of keys is unpredictable. If you need to traverse the keys in a certain order, you can sort the keys. A loop over the keys in the `temps` dictionary in alphabetic order is written as

```
>>> for city in sorted(temps):
...     print city
...
London
Madrid
Oslo
Paris
```

Python also has a special dictionary type, called `OrderedDict`, found in the `collections` module. This dictionary remembers the order of key-value pairs as they were created. A `for` loop over an `OrderedDict` object will always visit the keys in this particular order.

A key-value pair can be removed by `del d[key]`:

```
>>> del temps['Oslo']
>>> temps
{'Paris': 17.5, 'London': 15.4, 'Madrid': 26.0}
>>> len(temps) # no of key-value pairs in dictionary
3
```

Sometimes we need to take a copy of a dictionary:

```
>>> temps_copy = temps.copy()
>>> del temps_copy['Paris'] # this does not affect temps
>>> temps_copy
{'London': 15.4, 'Madrid': 26.0}
>>> temps
{'Paris': 17.5, 'London': 15.4, 'Madrid': 26.0}
```

Note that if two variables refer to the same dictionary and we change the contents of the dictionary through either of the variables, the change will be seen in both variables:

```
>>> t1 = temps
>>> t1['Stockholm'] = 10.0 # change t1
>>> temps # temps is also changed
{'Stockholm': 10.0, 'Paris': 17.5, 'London': 15.4, 'Madrid': 26.0}
```

To avoid that `temps` is affected by adding a new key-value pair to `t1`, `t1` must be a copy of `temps`.

Remark. In Python version 2.x, `temps.keys()` returns a list object while in Python version 3.x, `temps.keys()` only enables iterating over the keys. To write code that works with both versions one can use `list(temps.keys())` in the cases where a list is really needed and just `temps.keys()` in a `for` loop over the keys.

6.2.3 Example: Polynomials as Dictionaries

The keys in a dictionary are not restricted to be strings. In fact, any Python object whose contents cannot be changed can be used as key¹⁰. For example, we may use integers as keys in a dictionary. This is a handy way of representing polynomials, as will be explained next.

Consider the polynomial

$$p(x) = -1 + x^2 + 3x^7.$$

The data associated with this polynomial can be viewed as a set of power-coefficient pairs, in this case the coefficient -1 belongs to power 0, the coefficient 1 belongs to power 2, and the coefficient 3 belongs to power 7. A dictionary can be used to map a power to a coefficient:

```
p = {0: -1, 2: 1, 7: 3}
```

A list can, of course, also be used, but in this case we must fill in all the zero coefficients too, since the index must match the power:

```
p = [-1, 0, 1, 0, 0, 0, 0, 3]
```

The advantage with a dictionary is that we need to store only the non-zero coefficients. For the polynomial $1 + x^{100}$ the dictionary holds two elements while the list holds 101 elements (see Exercise 6.16).

The following function can be used to evaluate a polynomial represented as a dictionary:

```
def poly1(data, x):
    sum = 0.0
    for power in data:
        sum += data[power]*x**power
    return sum
```

The `data` argument must be a dictionary where `data[power]` holds the coefficient associated with the term `x**power`. A more compact implementation can make use of Python's `sum` function to sum the elements of a list:

```
def poly1(data, x):
    return sum([data[p]*x**p for p in data])
```

That is, we first make a list of the terms in the polynomial using a list comprehension, and then we feed this list to the `sum` function. Note that the name `sum` is different in the two implementations: In the first, `sum` is a `float` object, and in the second, `sum` is a function. When we set `sum=0.0` in the first implementation, we bind the name `sum` to a

¹⁰ Such objects are known as *immutable* data types and consist of `int`, `float`, `complex`, `str`, and `tuple`. Lists and dictionaries can change their contents and are called *mutable* objects. These cannot be used as keys in dictionaries. If you desire a list as key, use a tuple instead.

new `float` object, and the built-in Python function associated with the name `sum` is then no longer accessible inside the `poly1` function¹¹. Outside the function, nevertheless, `sum` will be the summation function (unless we have bound the global name `sum` to another object somewhere else in the main program).

With a list instead of dictionary for representing the polynomial, a slightly different evaluation function is needed:

```
def poly2(data, x):
    sum = 0
    for power in range(len(data)):
        sum += data[power]*x**power
    return sum
```

If there are many zeros in the `data` list, `poly2` must perform all the multiplications with the zeros, while `poly1` computes with the non-zero coefficients only and is hence more efficient.

Another major advantage of using a dictionary to represent a polynomial rather than a list is that negative powers are easily allowed, e.g.,

```
p = {-3: 0.5, 4: 2}
```

can represent $\frac{1}{2}x^{-3} + 2x^4$. With a list representation, negative powers require much more book-keeping. We may, for example, set

```
p = [0.5, 0, 0, 0, 0, 0, 0, 2]
```

and remember that `p[i]` is the coefficient associated with the power `i-3`. In particular, the `poly2` function will no longer work for such lists, while the `poly1` function works also for dictionaries with negative keys (powers).

There is (in Python v2.7/v3.1) a dictionary counterpart to list comprehensions, called *dictionary comprehensions*, for quickly generating parameterized key-value pairs with a `for` loop. Such a construction is convenient to generate the coefficients in a polynomial:

```
from math import factorial
d = {k: (-1)**k/factorial(k) for k in range(n+1)}
```

The `d` dictionary now contains the power-coefficient pairs of the Taylor polynomial of degree `n` for e^{-x} .

You are now encouraged to solve Exercise 6.17 on page 333 to become more familiar with the concept of dictionaries.

¹¹ This is not strictly correct, because `sum` is a local variable while the summation function is associated with a global name `sum`, which can be reached through `globals()['sum']`.

6.2.4 Dictionaries with Default Values and Ordering

Dictionaries with Default Values. Looking up keys that are not present in the dictionary requires special treatment. Consider a polynomial dictionary of the type introduced in Chapter 6.2.3. Say we have $2x^{-3} - 1.5x^{-1} - 2x^2$ represented by

```
p1 = {-3: 2, -1: -1.5, 2: -2}
```

If the code tries to look up `p1[1]`, this operation results in a `KeyError` since 1 is not a registered key in `p1`. We therefore need to do either

```
if key in p1:
    value = p1[key]
```

or use

```
value = p1.get(key, 0.0)
```

where `p1.get` returns `p1[key]` if `key` in `p1` and the default value `0.0` if not. A third possibility is to work with a dictionary with a default value:

```
from collections import defaultdict

def polynomial_coeff_default():
    # default value for polynomial dictionary
    return 0.0

p2 = defaultdict(polynomial_coeff_default)
p2.update(p1)
```

The `p2` can be indexed by any key, and for unregistered keys the `polynomial_coeff_default` function is called to provide a value. This must be a function without arguments. Usually, a separate function is never made, but either a type is inserted or a lambda function. The example above is equivalent to

```
p2 = defaultdict(lambda: 0.0)
p2 = defaultdict(float)
```

In the latter case `float()` is called for each unknown key, and `float()` returns a `float` object with zero value. Now we can look up `p2[1]` and get the default value 0. It must be remarked that this key is then a part of the dictionary:

```
>>> p2 = defaultdict(lambda: 0.0)
>>> p2.update({2: 8}) # only one key
>>> p2[1]
0.0
>>> p2[0]
0.0
>>> p2[-2]
0.0
>>> print p2
{0: 0.0, 1: 0.0, 2: 8, -2: 0.0}
```

Ordered Dictionaries. The elements of a dictionary has an undefined order. For example,

```
>>> p1 = {-3: 2, -1: -1.5, 2: -2}
>>> print p1
{2: -2, -3: 2, -1: -1.5}
```

One can control the order by sorting the keys, either by the default sorting (alphabetically for string keys, ascending order for number keys):

```
>>> for key in sorted(p1):
...     print key, p1[key]
...
-3 2
-1 -1.5
2 -2
```

The `sorted` function also accept an optional argument where the user can supply a function that sorts two keys (see Exercise 3.32).

However, Python features a dictionary type that preserves the order of the keys as they were registered:

```
>>> from collections import OrderedDict
>>> p2 = OrderedDict({-3: 2, -1: -1.5, 2: -2})
>>> print p2
OrderedDict([(2, -2), (-3, 2), (-1, -1.5)])
>>> p2[-5] = 6
>>> for key in p2:
...     print key, p2[key]
...
2 -2
-3 2
-1 -1.5
-5 6
```

Here is an example with dates as keys where the order is important.

```
>>> data = {'Jan 2': 33, 'Jan 16': 0.1, 'Feb 2': 2}
>>> for date in data:
...     print date, data[date]
...
Feb 2 2
Jan 2 33
Jan 16 0.1
```

The order of the keys in the loop is not the right registered order, but this is easily achieved by `OrderedDict`

```
>>> data = OrderedDict()
>>> data['Jan 2'] = 33
>>> data['Jan 16'] = 0.1
>>> data['Feb 2'] = 2
>>> for date in data:
...     print date, data[date]
...
Jan2 33
Jan 16 0.1
Feb 2 2
```

A comment on alternative solutions should be made here. Trying to sort the data dictionary when it is an ordinary `dict` object does not help, as by default the sorting will be alphabetically, resulting in the sequence 'Feb 2', 'Jan 16', and 'Jan 2'. What does help, however, is to use Python's `datetime` objects as keys reflecting dates, since these objects will be correctly sorted. A `datetime` object can be created from a string like 'Jan 2, 2017' using a special syntax (see the module documentation). The relevant code is

```
>>> import datetime
>>> data = {}
>>> d = datetime.datetime.strptime # short form
>>> data[d('Jan 2, 2017', '%b %d, %Y')] = 33
>>> data[d('Jan 16, 2017', '%b %d, %Y')] = 0.1
>>> data[d('Feb 2, 2017', '%b %d, %Y')] = 2
```

Printing out in sorted order gives the right sequence of dates:

```
>>> for date in sorted(data):
...     print date, data[date]
...
2017-01-02 00:00:00 33
2017-01-16 00:00:00 0.1
2017-02-02 00:00:00 2
```

The time is automatically part of a `datetime` object and set to 00:00:00 when not specified.

While `OrderedDict` provides a simpler and shorter solution to keeping keys (here dates) in the right order in a dictionary, using `datetime` objects for dates has many advantages: dates can be formatted and written out in various ways, counting days between two dates is easy (see Appendix A.1.1), calculating the corresponding week number and name of the weekday is supported, to mention some functionality.

6.2.5 Example: File Data in Dictionaries

Problem. The file `files/densities.dat` contains a table of densities of various substances measured in g/cm^3 :

air	0.0012
gasoline	0.67
ice	0.9
pure water	1.0
seawater	1.025
human body	1.03
limestone	2.6
granite	2.7
iron	7.8
silver	10.5
mercury	13.6
gold	18.9
platinum	21.4
Earth mean	5.52
Earth core	13
Moon	3.3
Sun mean	1.4
Sun core	160
proton	2.8E+14

In a program we want to access these density data. A dictionary with the name of the substance as key and the corresponding density as value seems well suited for storing the data.

Solution. We can read the `densities.dat` file line by line, split each line into words, use a float conversion of the last word as density value, and the remaining one or two words as key in the dictionary.

```
def read_densities(filename):
    infile = open(filename, 'r')
    densities = {}
    for line in infile:
        words = line.split()
        density = float(words[-1])

        if len(words[:-1]) == 2:
            substance = words[0] + ' ' + words[1]
        else:
            substance = words[0]

        densities[substance] = density
    infile.close()
    return densities

densities = read_densities('densities.dat')
```

This code is found in the file `density.py`. With string operations from Chapter 6.3.1 we can avoid the special treatment of one or two words in the name of the substance and achieve simpler and more general code, see Exercise 6.10.

6.2.6 Example: File Data in Nested Dictionaries

Problem. We are given a data file with measurements of some properties with given names (here A, B, C ...). Each property is measured a given number of times. The data are organized as a table where the rows contain the measurements and the columns represent the measured properties:

	A	B	C	D
1	11.7	0.035	2017	99.1
2	9.2	0.037	2019	101.2
3	12.2	no	no	105.2
4	10.1	0.031	no	102.1
5	9.1	0.033	2009	103.3
6	8.7	0.036	2015	101.9

The word “no” stands for no data, i.e., we lack a measurement. We want to read this table into a dictionary `data` so that we can look up measurement no. `i` of (say) property `C` as `data['C'][i]`. For each property `p`, we want to compute the mean of all measurements and store this as `data[p]['mean']`.

Algorithm. The algorithm for creating the `data` dictionary goes as follows:

```

examine the first line: split it into words and
    initialize a dictionary with the property names
    as keys and empty dictionaries ({} ) as values
for each of the remaining lines in the file:
    split the line into words
    for each word after the first:
        if the word is not "no":
            transform the word to a real number and store
            the number in the relevant dictionary

```

Implementation. The solution requires familiarity with dictionaries and list slices (also called sublists, see Chapter 2.4.3). A new aspect needed in the solution is *nested dictionaries*, that is, dictionaries of dictionaries. The latter topic is first explained, via an example:

```
>>> d = {'key1': {'key1': 2, 'key2': 3}, 'key2': 7}
```

Observe here that the value of `d['key1']` is a dictionary which we can index with its keys `key1` and `key2`:

```
>>> d['key1']          # this is a dictionary
{'key2': 3, 'key1': 2}
>>> type(d['key1'])   # proof
<type 'dict'>
>>> d['key1']['key1'] # index a nested dictionary
2
>>> d['key1']['key2']
3
```

In other words, repeated indexing works for nested dictionaries as for nested lists. The repeated indexing does not apply to `d['key2']` since that value is just an integer:

```
>>> d['key2']['key1']
...
TypeError: unsubscriptable object
>>> type(d['key2'])
<type 'int'>
```

When we have understood the concept of nested dictionaries, we are in a position to present a complete code that solves our problem of loading the tabular data in the file `table.dat` into a nested dictionary `data` and computing mean values. First, we list the program, stored in the file `table2dict.py`, and display the program's output. Thereafter, we dissect the code in detail.

```

infile = open('table.dat', 'r')
lines = infile.readlines()
infile.close()
data = {} # data[property][measurement_no] = propertyvalue
first_line = lines[0]

```

```

properties = first_line.split()
for p in properties:
    data[p] = {}

for line in lines[1:]:
    words = line.split()
    i = int(words[0])          # measurement number
    values = words[1:]        # values of properties
    for p, v in zip(properties, values):
        if v != 'no':
            data[p][i] = float(v)

# Compute mean values
for p in data:
    values = data[p].values()
    data[p]['mean'] = sum(values)/len(values)

for p in sorted(data):
    print 'Mean value of property %s = %g' % (p, data[p]['mean'])

```

The corresponding output from this program becomes

```

Mean value of property A = 10.1667
Mean value of property B = 0.0344
Mean value of property C = 2015
Mean value of property D = 102.133

```

To view the nested data dictionary, we may insert

```
import scitools.pprint2; scitools.pprint2.pprint(data)
```

which produces something like

```

{'A': {1: 11.7, 2: 9.2, 3: 12.2, 4: 10.1, 5: 9.1, 6: 8.7,
      'mean': 10.1667},
 'B': {1: 0.035, 2: 0.037, 4: 0.031, 5: 0.033, 6: 0.036,
      'mean': 0.0344},
 'C': {1: 2017, 2: 2019, 5: 2009, 6: 2015, 'mean': 2015},
 'D': {1: 99.1,
      2: 101.2,
      3: 105.2,
      4: 102.1,
      5: 103.3,
      6: 101.9,
      'mean': 102.133}}

```

Dissection. To understand a computer program, you need to understand what the result of every statement is. Let us work through the code, almost line by line, and see what it does.

First, we load all the lines of the file into a list of strings called `lines`. The `first_line` variable refers to the string

```
'      A      B      C      D'
```

We split this line into a list of words, called `properties`, which then contains

```
['A', 'B', 'C', 'D']
```

With each of these property names we associate a dictionary with the measurement number as key and the property value as value, but first we must create these “inner” dictionaries as empty before we can add the measurements:

```
for p in properties:
    data[p] = {}
```

The first pass in the `for` loop picks out the string

```
'1    11.7    0.035    2017    99.1'
```

as the `line` variable. We split this line into words, the first word (`words[0]`) is the measurement number, while the rest `words[1:]` is a list of property values, here named `values`. To pair up the right properties and values, we loop over the `properties` and `values` lists simultaneously:

```
for p, v in zip(properties, values):
    if v != 'no':
        data[p][i] = float(v)
```

Recall that some values may be missing and we drop to record that value¹². Because the `values` list contains strings (words) read from the file, we need to explicitly transform each string to a `float` number before we can compute with the values.

After the `for line in lines[1:]` loop, we have a dictionary `data` of dictionaries where all the property values are stored for each measurement number and property name. Figure 6.1 shows a graphical representation of the `data` dictionary.

It remains to compute the average values. For each property name `p`, i.e., key in the `data` dictionary, we can extract the recorded values as the list `data[p].values()` and simply send this list to Python's `sum` function and divide by the number of measured values for this property, i.e., the length of the list:

```
for p in data:
    values = data[p].values()
    data[p]['mean'] = sum(values)/len(values)
```

Alternatively, we can write an explicit loop to compute the average:

```
for p in data:
    sum_values = 0
    for value in data[p]:
        sum_values += value
    data[p]['mean'] = sum_values/len(data[p])
```

When we want to look up a measurement no. `n` of property `B`, we must recall that this particular measurement may be missing so we must do a test if `n` is key in the dictionary `data[p]`:

```
if n in data['B']:
    value = data['B'][n]

# alternative:
value = data['B'][n] if n in data['B'] else None
```

¹² We could, alternatively, set the value to `None`.

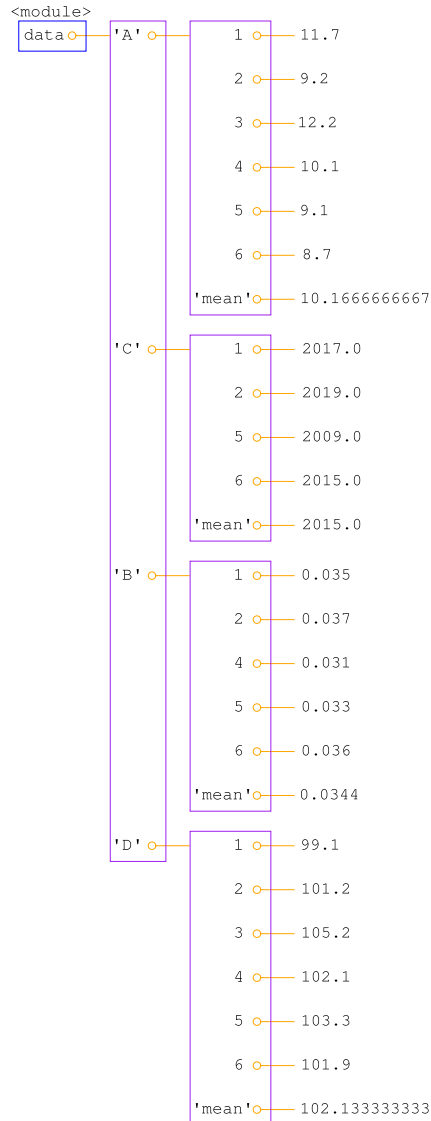

Fig. 6.1 Illustration of the nested dictionary created in the `table2dict.py` program.

6.2.7 Example: Comparing Stock Prices

Problem. We want to compare the evolution of the stock prices of three giant companies in the computer industry: Microsoft, Sun Microsystems, and Google. Relevant data files for stock prices can be downloaded from *finance.yahoo.com*. Fill in the company’s name and click on “GET QUOTES” in the top bar of this page, then choose “Historical Prices”. On the resulting web page we can specify start and end dates for the historical prices of the stock. We let this be January 1, 1988, for Microsoft and Sun, and January 1, 2005, for Google. The end dates were set to June 1, 2008, in this example. Ticking off “Monthly”

values and clicking “Get Prices” result in a table of stock prices. We can download the data in a tabular format by clicking “Download To Spreadsheet” below the table. Here is an example of such a file:

```
Date,Open,High,Low,Close,Volume,Adj Close
2008-06-02,12.91,13.06,10.76,10.88,16945700,10.88
2008-05-01,15.50,16.37,12.37,12.95,26140700,12.95
2008-04-01,15.78,16.23,14.62,15.66,10330100,15.66
2008-03-03,16.35,17.38,15.41,15.53,12238800,15.53
2008-02-01,17.47,18.03,16.06,16.40,12147900,16.40
2008-01-02,17.98,18.14,14.20,17.50,15156100,17.50
2007-12-03,20.61,21.55,17.96,18.13,9869900,18.13
2007-11-01,5.65,21.60,5.10,20.78,17081500,20.78
```

The file format is simple: columns are separated by comma, the first line contains column headings, and the data lines have the date in the first column and various measures of stock prices in the next columns. Reading about the meaning of the various data on the Yahoo! web pages reveals that our interest concerns the final column (these prices are adjusted for splits and dividends). Three relevant data files can be found in `src/files` with the names `company_monthly.csv`, where `company` is Microsoft, Sun, or Google.

The task is to plot the evolution of stock prices of the three companies. It is natural to scale the prices to start at a unit value in January 1988 and let the Google price start at the maximum of the Sun and Microsoft stock values in January 2005.

Solution. There are two major parts of this problem: (i) reading the file and (ii) plotting the data. The reading part is quite straightforward, while the plotting part needs some special considerations since the “x” values in the plot are dates and not real numbers. In the forthcoming text we solve the individual subproblems one by one, showing the relevant Python snippets. The complete program is found in the file `stockprices.py`.

We start with the reading part. Since the reading will be repeated for three files, we make a function with the filename as argument. The result of reading a file should be two lists (or arrays) with the dates and the stock prices, respectively. We therefore return these two lists from the function. The algorithm for reading the data goes as follows:

```
open the file
create two empty lists, dates and prices, for collecting the data
read the first line (of no interest)
for each line in the rest of the file:
    split the line wrt. comma
    append the first word on the line to the dates list
    append the last word on the line to the prices list
close the file
```

There are a couple of additional points to consider. First, the words on a line are strings, and at least the prices (last word) should be converted

to a float. The first word, the date, has the form year-month-day (e.g., 2008-02-04). Since we asked for monthly data only, the day part is of no interest. Skipping the day part can be done by extracting a substring of the date string: `date[:-3]`, which means everything in the string except the last three characters (see Chapter 6.3.1 for more on substrings). The remaining date specification is now of the form year-month (e.g., 2008-02), represented as a string. Turning this into a number for plotting is not so easy, so we keep this string as it is in the list of dates.

The second point of consideration in the algorithm above is the sequence of data in the two lists: the files have the most recent date at the top and the oldest at the bottom, while it is natural to plot the evolution of stock prices against *increasing* time. Therefore, we must reverse the two lists of data before we return them to the calling code.

The algorithm above, together with the two additional comments, can now be translated into Python code:

```
def read_file(filename):
    infile = open(filename, 'r')
    infile.readline() # read column headings
    dates = []; prices = []
    for line in infile:
        columns = line.split(',')
        date = columns[0]
        date = date[:-3] # skip day of month
        price = columns[-1]
        dates.append(date)
        prices.append(float(price))
    infile.close()
    dates.reverse()
    prices.reverse()
    return dates, prices
```

The reading of a file is done by a call to this function, e.g.,

```
dates_Google, prices_Google = read_file('stockprices_Google.csv')
```

Instead of working with separate variables for the file data, we may collect the data in dictionaries, with the company name as key. One possibility is to use two dictionaries:

```
dates = {}; prices = {}
d, p = read_file('stockprices_Sun.csv')
dates['Sun'] = d; prices['Sun'] = p
d, p = read_file('stockprices_Microsoft.csv')
dates['MS'] = d; prices['MS'] = p
d, p = read_file('stockprices_Google.csv')
dates['Google'] = d; prices['Google'] = p
```

We can also collect the dates and prices dictionaries in a dictionary data:

```
data = {'prices': prices, 'dates': dates}
```

Note that `data` is a nested dictionary, so that to extract, e.g., the prices of the Microsoft stock, one writes `data['prices']['MS']`.

The next task is to normalize the stock prices so that we can easily compare them. The idea is to let Sun and Microsoft start out with a unit price and let Google start out with the best of the Sun and Microsoft prices. Normalizing the Sun and Microsoft prices is done by dividing by the first prices:

```
norm_price = prices['Sun'][0]
prices['Sun'] = [p/norm_price for p in prices['Sun']]
```

with a similar code for the Microsoft prices. Normalizing the Google prices is more involved as we need to extract the prices of Sun and Microsoft stocks from January 2005. Since the `dates` and `prices` lists correspond to each other, element by element, we can get the index corresponding to the date '2005-01' in the list of dates and use this index to extract the corresponding price. The normalization can then be coded as

```
jan05_MS = prices['MS'][dates['MS'].index('2005-01')]
jan05_Sun = prices['Sun'][dates['Sun'].index('2005-01')]
norm_price = prices['Google'][0]/max(jan05_MS, jan05_Sun)
prices['Google'] = [p/norm_price for p in prices['Google']]
```

The purpose of the final plot is to show how the prices evolve in time. The problem is that our time data consists of strings of the form year-month. We need to convert this string information to some “x” coordinate information in the plot. The simplest strategy is to just plot the prices against the list index, i.e., the “x” coordinates correspond to counting months. Suitable lists of monthly based indices for Sun and Microsoft are straightforward to create with the `range` function:

```
x = {}
x['Sun'] = range(len(prices['Sun']))
x['MS'] = range(len(prices['MS']))
```

The “x” coordinates for the Google prices are somewhat more complicated, because the indices must start at the index corresponding to January 2005 in the Sun and Microsoft data. However, we extracted that index in the normalization of the Google prices, so we have already done most of the work:

```
jan05 = dates['Sun'].index('2005-01')
x['Google'] = range(jan05, jan05 + len(prices['Google']), 1)
```

The final step is to plot the three set of data:

```
from scitools.std import plot
plot(x['MS'], prices['MS'], 'r-',
     x['Sun'], prices['Sun'], 'b-',
     x['Google'], prices['Google'], 'y-',
     legend=('Microsoft', 'Sun', 'Google'))
```

Figure 6.2 displays the resulting plot. As seen from the plot, the best investment would be to start with Microsoft stocks in 1988 and switch

all the money to Google stocks in 2005. You can easily modify the program to explore what would happen if you started out with Sun stocks and switched to Google in 2005.

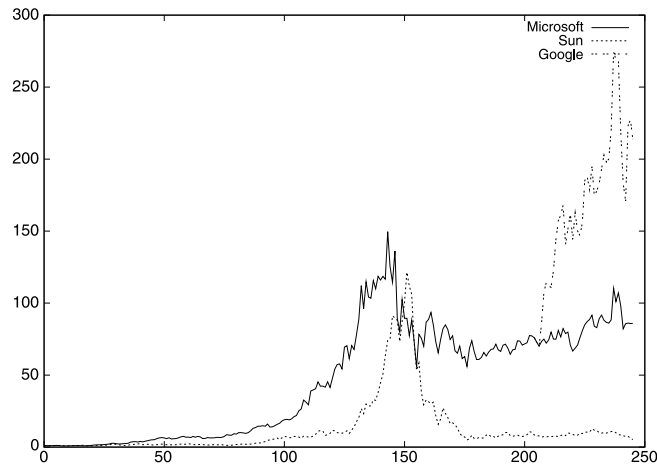

Fig. 6.2 The evolution of stock prices for three companies in the period January 1998 to June 2008.

Generalization. We can quite easily generalize the program to handle data from an arbitrary collection of companies, at least if we restrict the time period to be the same for all stocks. Exercise 6.18 asks you to do this. As you will realize, the use of dictionaries instead of separate variables in our program constitutes one important reason why the program becomes easy to extend. Avoiding different time periods for different price data also makes the generalized program simpler than the one we developed above.

6.3 Strings

Many programs need to manipulate text. For example, when we read the contents of a file into a string or list of strings (lines), we may want to change parts of the text in the string(s) – and maybe write out the modified text to a new file. So far in this chapter we have converted parts of the text to numbers and computed with the numbers. Now it is time to learn how to manipulate the text strings themselves.

6.3.1 Common Operations on Strings

Python has a rich set of operations on string objects. Some of the most common operations are listed below.

Substring Specification. The expression `s[i:j]` extracts the substring starting with character number `i` and ending with character number `j-1` (similarly to lists, 0 is the index of the first character):

```
>>> s = 'Berlin: 18.4 C at 4 pm'
>>> s[8:]      # from index 8 to the end of the string
'18.4 C at 4 pm'
>>> s[8:12]   # index 8, 9, 10 and 11 (not 12!)
'18.4'
```

A negative upper index counts, as usual, from the right such that `s[-1]` is the last element, `s[-2]` is the next last element, and so on.

```
>>> s[8:-1]
'18.4 C at 4 p'
>>> s[8:-8]
'18.4 C'
```

Searching for Substrings. The call `s.find(s1)` returns the index where the substring `s1` first appears in `s`. If the substring is not found, `-1` is returned.

```
>>> s.find('Berlin') # where does 'Berlin' start?
0
>>> s.find('pm')
20
>>> s.find('Oslo')   # not found
-1
```

Sometimes the aim is to just check if a string is contained in another string, and then we can use the syntax:

```
>>> 'Berlin' in s:
True
>>> 'Oslo' in s:
False
```

Here is a typical use of the latter construction in an if test:

```
>>> if 'C' in s:
...     print 'C found'
... else:
...     print 'no C'
...
C found
```

Two other convenient methods for checking if a string starts with or ends with a specified string are `startswith` and `endswith`:

```
>>> s.startswith('Berlin')
True
>>> s.endswith('am')
False
```

Substitution. The call `s.replace(s1, s2)` replaces substring `s1` by `s2` everywhere in `s`:

```
>>> s.replace(' ', '_')
'Berlin:_18.4_C_at_4_pm'
>>> s.replace('Berlin', 'Bonn')
'Bonn: 18.4 C at 4 pm'
```

A variant of the last example, where several string operations are put together, consists of replacing the text before the first colon¹³:

```
>>> s.replace(s[:s.find(':')], 'Bonn')
'Bonn: 18.4 C at 4 pm'
```

String Splitting. The call `s.split()` splits the string `s` into words separated by whitespace (space, tabulator, or newline):

```
>>> s.split()
['Berlin:', '18.4', 'C', 'at', '4', 'pm']
```

Splitting a string `s` into words separated by a text `t` can be done by `s.split(t)`. For example, we may split with respect to colon:

```
>>> s.split(':')
['Berlin', ' 18.4 C at 4 pm']
```

We know that `s` contains a city name, a colon, a temperature, and then C:

```
>>> s = 'Berlin: 18.4 C at 4 pm'
```

With `s.splitlines()`, a multi-line string is split into lines (very useful when a file has been read into a string and we want a list of lines):

```
>>> t = '1st line\n2nd line\n3rd line'
>>> print t
1st line
2nd line
3rd line
>>> t.splitlines()
['1st line', '2nd line', '3rd line']
```

Upper and Lower Case. `s.lower()` transforms all characters to their lower case equivalents, and `s.upper()` performs a similar transformation to upper case letters:

```
>>> s.lower()
'berlin: 18.4 c at 4 pm'
>>> s.upper()
'BERLIN: 18.4 C AT 4 PM'
```

Strings Are Constant. A string cannot be changed, i.e., any change always results in a new string. Replacement of a character is not possible:

¹³ Take a “break” and convince yourself that you understand how we specify the substring to be replaced.

```
>>> s[18] = 5
...
TypeError: 'str' object does not support item assignment
```

If we want to replace `s[18]`, a new string must be constructed, for example by keeping the substrings on either side of `s[18]` and inserting a `'5'` in between:

```
>>> s[:18] + '5' + s[19:]
'Berlin: 18.4 C at 5 pm'
```

Strings with Digits Only. One can easily test whether a string contains digits only or not:

```
>>> '214'.isdigit()
True
>>> ' 214 '.isdigit()
False
>>> '2.14'.isdigit()
False
```

Whitespace. We can also check if a string contains spaces only by calling the `isspace` method. More precisely, `isspace` tests for *whitespace*, which means the space character, newline, or the TAB character:

```
>>> '   '.isspace() # blanks
True
>>> '\n'.isspace() # newline
True
>>> '\t'.isspace() # TAB
True
>>> ''.isspace() # empty string
False
```

The `isspace` is handy for testing for blank lines in files. An alternative is to strip first and then test for an empty string:

```
>>> line = '\n'
>>> empty.strip() == ''
True
```

Stripping off leading and/or trailing spaces in a string is sometimes useful:

```
>>> s = ' text with leading/trailing space \n'
>>> s.strip()
'text with leading/trailing space'
>>> s.lstrip() # left strip
'text with leading/trailing space \n'
>>> s.rstrip() # right strip
' text with leading/trailing space'
```

Joining Strings. The opposite of the `split` method is `join`, which joins elements in a list of strings with a specified delimiter in between. That is, the following two types of statements are inverse operations:

```
t = delimiter.join(words)
words = t.split(delimiter)
```

An example on using `join` may be

```
>>> strings = ['Newton', 'Secant', 'Bisection']
>>> t = ', '.join(strings)
>>> t
'Newton, Secant, Bisection'
```

As an illustration of the usefulness of `split` and `join`, we want to remove the first two words on a line. This task can be done by first splitting the line into words and then joining the words of interest:

```
>>> line = 'This is a line of words separated by space'
>>> words = line.split()
>>> line2 = ' '.join(words[2:])
>>> line2
'a line of words separated by space'
```

There are many more methods in string objects. All methods are described in the Python Library Reference, see “[string methods](#)” in the [index](#).

6.3.2 Example: Reading Pairs of Numbers

Problem. Suppose we have a file consisting of pairs of real numbers, i.e., text of the form (a, b) , where a and b are real numbers. This notation for a pair of numbers is often used for points in the plane, vectors in the plane, and complex numbers. A sample file may look as follows:

```
(1.3,0)    (-1,2)    (3,-1.5)
(0,1)      (1,0)    (1,1)
(0,-0.01) (10.5,-1) (2.5,-2.5)
```

The file can be found as `read_pairs1.dat`. Our task is to read this text into a nested list `pairs` such that `pairs[i]` holds the pair with index i , and this pair is a tuple of two `float` objects. We assume that there are no blanks inside the parentheses of a pair of numbers (we rely on a `split` operation which would otherwise not work).

Solution. To solve this programming problem, we can read in the file line by line; for each line: split the line into words (i.e., split with respect to whitespace); for each word: strip off the parentheses, split with respect to comma, and convert the resulting two words to floats. Our brief algorithm can be almost directly translated to Python code:

```
lines = open('read_pairs1.dat', 'r').readlines()

pairs = [] # list of (n1, n2) pairs of numbers
for line in lines:
    words = line.split()
    for word in words:
```



```

word = word[1:-1] # strip off parenthesis
n1, n2 = word.split(',')
n1 = float(n1); n2 = float(n2)
pair = (n1, n2)
pairs.append(pair) # add 2-tuple to last row

```

This code is available in the file `read_pairs1.py`. Figure 6.3 shows a snapshot of the state of the variables in the program after having treated the first line. You should explain each line in the program to yourself, and compare your understanding with the figure.

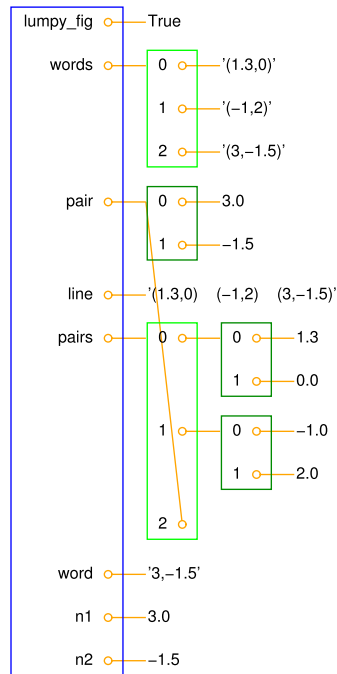

Fig. 6.3 Illustration of the variables in the `read_pairs.py` program after the first pass in the loop over words in the first line of the data file.

The output from the program becomes

```

[(1.3, 0.0),
 (-1.0, 2.0),
 (3.0, -1.5),
 (0.0, 1.0),
 (1.0, 0.0),
 (1.0, 1.0),
 (0.0, -0.01),
 (10.5, -1.0),
 (2.5, -2.5)]

```

We remark that our solution to this programming problem relies heavily on the fact that spaces inside the parentheses are not allowed. If spaces were allowed, the simple split to obtain the pairs on a line as words would not work. What can we then do?

We can first strip off all blanks on a line, and then observe that the pairs are separated by the text `')(('`. The first and last pair on a line

will have an extra parenthesis that we need to remove. The rest of code is similar to the previous code and can be found in `read_pairs2.py`:

```
infile = open('read_pairs2.dat', 'r')
lines = infile.readlines()

pairs = [] # list of (n1, n2) pairs of numbers
for line in lines:
    line = line.strip() # remove whitespace such as newline
    line = line.replace(' ', '') # remove all blanks
    words = line.split(',')
    # strip off leading/trailing parenthesis in first/last word:
    words[0] = words[0][1:] # (-1,3 -> -1,3
    words[-1] = words[-1][:-1] # 8.5,9) -> 8.5,9
    for word in words:
        n1, n2 = word.split(',')
        n1 = float(n1); n2 = float(n2)
        pair = (n1, n2)
        pairs.append(pair)

infile.close()
```

The program can be tested on the file `read_pairs2.dat`:

```
(1.3 , 0)      (-1 , 2 )      (3, -1.5)
(0 , 1)        ( 1, 0)        ( 1 , 1 )
(0,-0.01)     (10.5,-1)      (2.5, -2.5)
```

A third approach is to notice that if the pairs were separated by commas,

```
(1, 3.0),      (-1, 2),      (3, -1.5)
(0, 1),        (1, 0),        (1, 1)
```

the file text is very close to the Python syntax of a list of 2-tuples. By adding enclosing brackets, plus a comma at the end of each line,

```
[(1, 3.0),      (-1, 2),      (3, -1.5),
(0, 1),        (1, 0),        (1, 1),]
```

we have a string to which we can apply `eval` to get the pairs list directly. Here is the code doing this (program `read_pairs3.py`):

```
infile = open('read_pairs3.dat', 'r')
listtext = '['
for line in infile:
    # add line, without newline (line[:-1]), with a trailing comma:
    listtext += line[:-1] + ', '
infile.close()
listtext = listtext + ']'
pairs = eval(listtext)
```

In general, it is a good idea to construct file formats that are as close as possible to valid Python syntax such that one can take advantage of the `eval` or `exec` functions to turn text into “live objects”.

6.3.3 Example: Reading Coordinates

Problem. Suppose we have a file with coordinates (x, y, z) in three-dimensional space. The file format looks as follows:

```

x=-1.345      y= 0.1112      z= 9.1928
x=-1.231      y=-0.1251     z= 1001.2
x= 0.100      y= 1.4344E+6   z=-1.0100
x= 0.200      y= 0.0012     z=-1.3423E+4
x= 1.5E+5     y=-0.7666     z= 1027

```

The goal is to read this file and create a list with (x,y,z) 3-tuples, and thereafter convert the nested list to a two-dimensional array with which we can compute.

Note that there is sometimes a space between the = signs and the following number and sometimes not. Splitting with respect to space and extracting every second word is therefore not an option. We shall present three solutions.

Solution 1: Substring Extraction. The file format looks very regular with the $x=$, $y=$, and $z=$ texts starting in the same columns at every line. By counting characters, we realize that the $x=$ text starts in column 2, the $y=$ text starts in column 16, while the $z=$ text starts in column 31. Introducing

```

x_start = 2
y_start = 16
z_start = 31

```

the three numbers in a line string are obtained as the substrings

```

x = line[x_start+2:y_start]
y = line[y_start+2:z_start]
z = line[z_start+2:]

```

The following code, found in file `file2coor_v1.py`, creates the `coor` array with shape $(n, 3)$, where n is the number of (x, y, z) coordinates.

```

infile = open('xyz.dat', 'r')
coor = [] # list of (x,y,z) tuples
for line in infile:
    x_start = 2
    y_start = 16
    z_start = 31
    x = line[x_start+2:y_start]
    y = line[y_start+2:z_start]
    z = line[z_start+2:]
    print 'debug: x="%s", y="%s", z="%s"' % (x,y,z)
    coor.append((float(x), float(y), float(z)))
infile.close()

import numpy as np
coor = np.array(coor)
print coor.shape, coor

```

The `print` statement inside the loop is always wise to include when doing string manipulations, simply because counting indices for substring limits quickly leads to errors. Running the program, the output from the loop looks like this

```

debug: x="-1.345  ", y=" 0.1112  ", z=" 9.1928

```

for the first line in the file. The double quotes show the exact extent of the extracted coordinates. Note that the last quote appears on the next line. This is because `line` has a newline at the end (this newline must be there to define the end of the line), and the substring `line[z_start:]` contains the newline at the end of `line`. Writing `line[z_start:-1]` would leave the newline out of the z coordinate. However, this has no effect in practice since we transform the substrings to `float`, and an extra newline or other blanks make no harm.

The `coor` object at the end of the program has the value

```
[[-1.34500000e+00  1.11200000e-01  9.19280000e+00]
 [-1.23100000e+00 -1.25100000e-01  1.00120000e+03]
 [ 1.00000000e-01  1.43440000e+06 -1.01000000e+00]
 [ 2.00000000e-01  1.20000000e-03 -1.34230000e+04]
 [ 1.50000000e+05 -7.66600000e-01  1.02700000e+03]]
```

Solution 2: String Search. One problem with the solution approach above is that the program will not work if the file format is subject to a change in the column positions of `x=`, `y=`, or `z=`. Instead of hardcoding numbers for the column positions, we can use the `find` method in string objects to locate these column positions:

```
x_start = line.find('x=')
y_start = line.find('y=')
z_start = line.find('z=')
```

The rest of the code is similar to the complete program listed above, and the complete code is stored in the file `file2coor_v2.py`.

Solution 3: String Split. String splitting is a powerful tool, also in the present case. Let us split with respect to the equal sign. The first line in the file then gives us the words

```
['x', '-1.345', 'y', '0.1112', 'z', '9.1928']
```

We throw away the first word, and strip off the last character in the next word. The final word can be used as is. The complete program is found in the file `file2coor_v3.py` and looks like

```
infile = open('xyz.dat', 'r')
coor = [] # list of (x,y,z) tuples
for line in infile:
    words = line.split('=')
    x = float(words[1][:-1])
    y = float(words[2][:-1])
    z = float(words[3])
    coor.append((x, y, z))
infile.close()

import numpy as np
coor = np.array(coor)
print coor.shape, coor
```

More sophisticated examples of string operations appear in Chapter 6.4.4.

6.4 Reading Data from Web Pages

Python has a module `urllib` which makes it possible to read data from a web page as easily as we can read data from an ordinary file¹⁴. Before we do this, a few concepts from the Internet world must be touched.

6.4.1 About Web Pages

Web pages are viewed with a web browser. There are many browsers: Firefox, Internet Explorer, Safari, Opera, and Google Chrome to mention the most famous. Any web page you visit is associated with an address, usually something like

<http://www.some.where.net/some/file.html>

This type of web address is called a URL (which stands for Uniform Resource Locator¹⁵). The graphics you see in a web browser, i.e., the web page you see with your eyes, is produced by a series of commands that specifies the text on the page, the images, buttons to be pressed, etc. Roughly speaking, these commands are like statements in computer programs. The commands are stored in a text file and follow rules in a language, exactly as you are used to when writing statements in a programming language.

The common language for defining web pages is HTML. A web page is then simply a text file with text containing HTML commands. Instead of a physical file, the web page can also be the output text from a program. In that case the URL is the name of the program file.

The web browser interprets the text and the HTML commands, and then decides how to display the information visually. Let us demonstrate this for a very simple web page shown in Figure 6.4. This page was produced by the following text with embedded HTML commands:

```
<html>
<body bgcolor="orange">
<h1>A Very Simple HTML Page</h1> <!-- headline -->
Web pages are written in a language called
<a href="http://www.w3.org/MarkUp/Guide/">HTML</a>.
Ordinary text is written as ordinary text, but when we
need links, headlines, lists,
<ul>
<li><em>emphasized words</em>, or
<li><b>boldface text</b>,
</ul>
we need to embed the text inside HTML tags. We can also
insert GIF or PNG images, taken from other Internet sites,
if desired.
<hr> <!-- horizontal line -->

```

¹⁴ In principle this is true, but in practice the text in web pages tend to be much more complicated than the text in the files we have treated so far.

¹⁵ Another term is URI (Uniform Resource Identifier), which is replacing URL in technical documentation. We stick to URL, however, in this book because Python's tools for accessing resources on the Internet have `url` as part of module and function names.

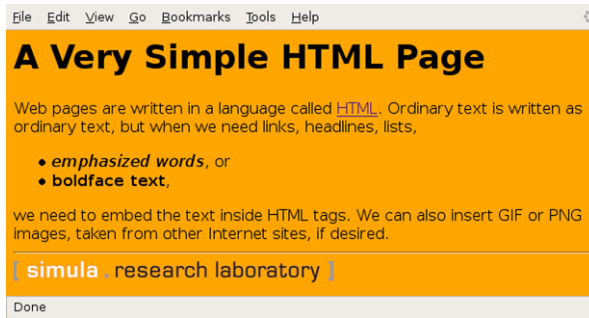

Fig. 6.4 Example of what a very simple HTML file looks like in a web browser.

```
</body>
</html>
```

A typical HTML command consists of an opening and a closing *tag*. For example, emphasized text is specified by enclosing the text inside `em` (emphasize) tags:

```
<em>emphasized words</em>
```

The opening tag is enclosed in less than and greater than signs, while the closing tag has an additional forward slash before the tag name.

In the HTML file we see an opening and closing `html` tag around the whole text in the file. Similarly, there is a pair of `body` tags, where the first one also has a parameter `bgcolor` which can be used to specify a background color in the web page. Section headlines are specified by enclosing the headline text inside `h1` tags. Subsection headlines apply `h2` tags, which results in a smaller font compared with `h1` tags. Comments appear inside `<!--` and `-->`. Links to other web pages are written inside `a` tags, with an argument `href` for the link's web address. Lists apply the `ul` (unordered list) tag, while each item is written with just an opening tag `li` (list item), but no closing tag is necessary. Images are also specified with just an opening tag having name `img`, and the image file is given as a file name or URL of a file, enclosed in double quotes, as the `src` parameter.

The ultra-quick HTML course in the previous paragraphs gives a glimpse of how web pages can be constructed. One can either write the HTML file by hand in a pure text editor, or one can use programs such as Dream Weaver to help design the page graphically in a user-friendly environment, and then the program can automatically generate the right HTML syntax in files.

6.4.2 How to Access Web Pages in Programs

Why is it useful to know some HTML and how web pages are constructed? The reason is that the web is full of information that we can

get access to through programs and use in new contexts. What we can get access to is not the visual web page you see, but the underlying HTML file. The information you see on the screen appear in text form in the HTML file, and by extracting text, we can get hold of the text's information in a program.

Given the URL as a string stored in a variable, there are two ways of accessing the HTML text in a Python program:

1. Download the HTML file and store it as a local file with a given name, say `webpage.html`:

```
import urllib
url = 'http://www.simula.no/research/scientific/cbc'
urllib.urlretrieve(url, filename='webpage.html')
```

2. Open the HTML file as a file-like object:

```
infile = urllib.urlopen(url)
```

This `infile` object has methods such as `read`, `readline`, and `readlines`.

6.4.3 Example: Reading Pure Text Files

Some web pages are just pure text files. Extracting the data from such pages are as easy as reading ordinary text files. Here is an example of historic weather data from the UK:

<http://www.metoffice.gov.uk/climate/uk/stationdata/>

We may choose a station, say Oxford, which directs us to the page

<http://www.metoffice.gov.uk/climate/uk/stationdata/oxforddata.txt>

We can download this data file by

```
import urllib
url = \
'http://www.metoffice.gov.uk/climate/uk/stationdata/oxforddata.txt'
urllib.urlretrieve(url, filename='Oxford.txt')
```

The files looks as follows:

```
Oxford
Location: 4509E 2072N, 63 metres amsl
Estimated data is marked with a * after the value.
Missing data (more than 2 days missing in month) is marked by ---.
Sunshine data taken from an automatic ...
  yyyy  mm   tmax   tmin   af   rain   sun
        degC degC   days   mm   hours
  1853   1    8.4    2.7    4   62.8   ---
  1853   2    3.2   -1.8   19   29.3   ---
  1853   3    7.7   -0.6   20   25.9   ---
  1853   4   12.6    4.5    0   60.1   ---
  1853   5   16.8    6.1    0   59.5   ---
...
  2010   1    4.7   -1.0   17   56.4   68.2
  2010   2    7.1    1.3    7   79.8   59.3
  2010   3   11.3    3.2    8   47.6  130.2
```

2010	4	15.8	4.9	0	25.5	209.5	
2010	5	17.6	7.3	0	28.6	207.4	
2010	6	23.0	11.1	0	34.5	230.5	
2010	7	23.3*	14.1*	0*	24.4*	184.4*	Provisional
2010	8	21.4	12.0	0	146.2	123.8	Provisional
2010	9	19.0	10.0	0	48.1	118.6	Provisional
2010	10	14.6	7.4	2	43.5	128.8	Provisional

After the 7 header lines the data consists of 7 or 8 columns of numbers, the 8th being of no interest. Some numbers may have * or # appended to them, but this character must be stripped off before using the number. The columns contain the year, the month number (1–12), average maximum temperature, average minimum temperature, total number of days of air frost (af) during the month, total rainfall during the month, and the total number of hours with sun during the month. The temperature averages are taken over the maximum and minimum temperatures for all days in the month. Unavailable data are marked by three dashes.

The data can be conveniently stored in a dictionary with, e.g., three main keys: place (name), location (the info on the 2nd), and data. The latter is a dictionary with two keys: year and month.

The following program creates the data dictionary:

```
infile = open(local_file, 'r')
data = {}
data['place'] = infile.readline().strip()
data['location'] = infile.readline().strip()
# Skip the next 5 lines
for i in range(5):
    infile.readline()

data['data'] = {}
for line in infile:
    columns = line.split()

    year = int(columns[0])
    month = int(columns[1])

    if columns[-1] == 'Provisional':
        del columns[-1]
    for i in range(2, len(columns)):
        if columns[i] == '---':
            columns[i] = None
        elif columns[i][-1] == '*' or columns[i][-1] == '#':
            # Strip off trailing character
            columns[i] = float(columns[i][:-1])
        else:
            columns[i] = float(columns[i])

    tmax, tmin, air_frost, rain, sun = columns[2:]

    if not year in data['data']:
        data['data'][year] = {}
    data['data'][year][month] = {'tmax': tmax,
                                 'tmin': tmin,
                                 'air frost': air_frost,
                                 'sun': sun}
```

The code is available in the file `historic_weather.py`.

With a few lines of code, we can extract the data we want, say a two-dimensional array of the number of sun hours in a month (these data are available from year 1929):

```
sun = [[data['data'][y][m]['sun'] for m in range(1,13)] \
       for y in range(1929, 2010)]
import numpy as np
sun = np.array(sun)
```

One can now do analysis of the data as exemplified in Chapter 2.6.2 and Exercise 5.8.

6.4.4 Example: Extracting Data from HTML

Very often, interesting data in a web page appear inside HTML code. We then need to interpret the text using string operations and store the data in variables. An example will clarify the principle.

The web site www.worldclimate.com contains data on temperature and rainfall in a large number of cities around the world. For example,

<http://www.worldclimate.com/cgi-bin/data.pl?ref=N38W009+2100+08535W>

contains a table of the average rainfall for each month of the year in the town Lisbon, Portugal. Our task is to download this web page and extract the tabular data (rainfall per month) in a list.

Downloading the file is done with `urllib` as explained in Chapters 6.4.2 and 6.4.3. Before attempting to read and interpret the text in the file, we need to look at the HTML code to find the interesting parts and determine how we can extract the data. The table with the rainfall data appears in the middle of the file. A sketch of the relevant HTML code goes as follows:

```
<p>Weather station <strong>LISBOA</strong> ...
<tr><th align=right><th> Jan<th> Feb<th> ... <br>
<tr><td> mm <td align=right> 95.2 <td align=right> 86.7 ...<br>
<tr><td>inches <td align=right>3.7<td align=right>3.4 ...<br>
```

Our task is to walk through the file line by line and stop for processing the first and third line above:

```
infile = open('Lisbon_rainfall.html', 'r')
rainfall = []
for line in infile:
    if 'Weather station' in line:
        station = line.split('</strong>')[0].split('<strong>')[0]
    if '<td> mm <td' in line:
        data = line.split('<td align=right>')
```

The resulting data list looks like

```
['<tr><td> mm ', ' 95.2 ', ..., '702.4<br> \n']
```

To process this list further, we strip off the `
...` part of the last element:

```
data[-1] = data[-1].split('<br>')[0]
```

Then we drop the first element and convert the others to float objects:

```
data = [float(x) for x in data[1:]]
```

Now we have the rainfall data for each month as a list of real numbers. The complete program appears in the file `Lisbon_rainfall.py`. The recipe provided in this example can be used to interpret many other types of web pages where HTML code and data are wired together.

6.5 Writing Data to File

Writing data to file is easy. There is basically one function to pay attention to: `outfile.write(s)`, which writes a string `s` to a file handled by the file object `outfile`. Unlike `print`, `outfile.write(s)` does not append a newline character to the written string. It will therefore often be necessary to add a newline character,

```
outfile.write(s + '\n')
```

if the string `s` is meant to appear on a single line in the file and `s` does not already contain a trailing newline character. File writing is then a matter of constructing strings containing the text we want to have in the file and for each such string call `outfile.write`.

Writing to a file demands the file object `f` to be opened for writing:

```
# write to new file, or overwrite file:
outfile = open(filename, 'w')

# append to the end of an existing file:
outfile = open(filename, 'a')
```

6.5.1 Example: Writing a Table to File

Problem. As a worked example of file writing, we shall write out a nested list with tabular data to file. A sample list may take look as

```
[ [ 0.75,          0.29619813, -0.29619813, -0.75          ],
  [ 0.29619813,   0.11697778, -0.11697778, -0.29619813 ],
  [-0.29619813, -0.11697778,  0.11697778,  0.29619813 ],
  [-0.75,        -0.29619813,  0.29619813,  0.75          ] ]
```

Solution. We iterate through the rows (first index) in the list, and for each row, we iterate through the column values (second index) and write each value to the file. At the end of each row, we must insert a newline character in the file to get a linebreak. The code resides in the file `write1.py`:

```

data = [[ 0.75,      0.29619813, -0.29619813, -0.75      ],
        [ 0.29619813, 0.11697778, -0.11697778, -0.29619813],
        [-0.29619813, -0.11697778, 0.11697778, 0.29619813],
        [-0.75,      -0.29619813, 0.29619813, 0.75      ]]

outfile = open('tmp_table.dat', 'w')
for row in data:
    for column in row:
        outfile.write('%14.8f' % column)
    outfile.write('\n')
outfile.close()

```

The resulting data file becomes

```

0.75000000    0.29619813   -0.29619813   -0.75000000
0.29619813    0.11697778   -0.11697778   -0.29619813
-0.29619813   -0.11697778    0.11697778    0.29619813
-0.75000000   -0.29619813    0.29619813    0.75000000

```

An extension of this program consists in adding column and row headings:

```

      column 1      column 2      column 3      column 4
row 1    0.75000000    0.29619813   -0.29619813   -0.75000000
row 2    0.29619813    0.11697778   -0.11697778   -0.29619813
row 3   -0.29619813   -0.11697778    0.11697778    0.29619813
row 4   -0.75000000   -0.29619813    0.29619813    0.75000000

```

To obtain this end result, we need to add some statements to the program `write1.py`. For the column headings we need to know the number of columns, i.e., the length of the rows, and loop from 1 to this length:

```

ncolumns = len(data[0])
outfile.write('      ')
for i in range(1, ncolumns+1):
    outfile.write('%10s      ' % ('column %2d' % i))
outfile.write('\n')

```

Note the use of a nested `printf` construction: The text we want to insert is itself a `printf` string. We could also have written the text as `'column ' + str(i)`, but then the length of the resulting string would depend on the number of digits in `i`. It is recommended to always use `printf` constructions for a tabular output format, because this gives automatic padding of blanks so that the width of the output strings remain the same. As always, the tuning of the widths is done in a trial-and-error process.

To add the row headings, we need a counter over the row numbers:

```

row_counter = 1
for row in data:
    outfile.write('row %2d' % row_counter)
    for column in row:
        outfile.write('%14.8f' % column)
    outfile.write('\n')
    row_counter += 1

```

The complete code is found in the file `write2.py`. We could, alternatively, iterate over the indices in the list:

```

for i in range(len(data)):
    outfile.write('row %2d' % (i+1))
    for j in range(len(data[i])):
        outfile.write('%14.8f' % data[i][j])
    outfile.write('\n')

```

6.5.2 Standard Input and Output as File Objects

Reading user input from the keyboard applies the function `raw_input` as explained in Chapter 4.1. The keyboard is a medium that the computer in fact treats as a file, referred to as *standard input*.

The `print` command prints text in the terminal window. This medium is also viewed as a file from the computer's point of view and called *standard output*. All general-purpose programming languages allow reading from standard input and writing to standard output. This reading and writing can be done with two types of tools, either file-like objects or special tools like `raw_input` (see Chapter 4.1.1) and `print` in Python. We will here describe the file-like objects: `sys.stdin` for standard input and `sys.stdout` for standard output. These objects behave as file objects, except that they do not need to be opened or closed. The statement

```
s = raw_input('Give s:')
```

is equivalent to

```
print 'Give s: ',
s = sys.stdin.readline()
```

Recall that the trailing comma in the `print` statement avoids the new-line that `print` by default adds to the output string. Similarly,

```
s = eval(raw_input('Give s:'))
```

is equivalent to

```
print 'Give s: ',
s = eval(sys.stdin.readline())
```

For output to the terminal window, the statement

```
print s
```

is equivalent to

```
sys.stdout.write(s + '\n')
```

Why it is handy to have access to standard input and output as file objects can be illustrated by an example. Suppose you have a function that reads data from a file object `infile` and writes data to a file object `outfile`. A sample function may take the form

```
def x2f(infile, outfile, f):
    for line in infile:
        x = float(line)
        y = f(x)
        outfile.write('%g\n' % y)
```

This function works with all types of files, including web pages as `infile` (see Chapter 6.4). With `sys.stdin` as `infile` and/or `sys.stdout` as `outfile`, the `x2f` function also works with standard input and/or standard output. Without `sys.stdin` and `sys.stdout`, we would need different code, employing `raw_input` and `print`, to deal with standard input and output. Now we can write a single function that deals with all file media in a unified way.

There is also something called *standard error*. Usually this is the terminal window, just as standard output, but programs can distinguish between writing ordinary output to standard output and error messages to standard error, and these output media can be redirected to, e.g., files such that one can separate error messages from ordinary output. In Python, standard error is the file-like object `sys.stderr`. A typical application of `sys.stderr` is to report errors:

```
if x < 0:
    sys.stderr.write('Illegal value of x'); sys.exit(1)
```

This message to `sys.stderr` is an alternative to `print` or raising an exception.

Redirecting Standard Input, Output, and Error. Standard output from a program `prog` can be redirected to a file `output` instead of the screen, by using the greater than sign¹⁶:

```
Terminal
Terminal> prog > output
```

Similarly, output to the medium called *standard error* can be redirected by

```
Terminal
Terminal> prog &> output
```

For example, error messages are normally written to standard error, which is exemplified in this little terminal session on a Unix machine:

```
Terminal
Unix> ls bla-bla1 bla-bla2
ls: cannot access bla-bla1: No such file or directory
ls: cannot access bla-bla2: No such file or directory
Unix> ls bla-bla1 bla-bla2 &> errors
Unix> cat errors # print the file errors
```

¹⁶ `prog` can be any program, including a Python program run as, e.g., `python myprog.py`.

```
ls: cannot access bla-bla1: No such file or directory
ls: cannot access bla-bla2: No such file or directory
```

When the program reads from standard input (the keyboard), we can equally well redirect standard input to a file, say with name `raw_input`, such that the program reads from this file rather than from the keyboard:

```
Terminal> prog < input
```

Combinations are also possible:

```
Terminal> prog < input > output
```

Note. The redirection of standard output, input, and error does not work for programs run inside IPython, only when run directly in the operating system in a terminal window.

Inside a Python program we can also let standard input, output, and error work with ordinary files instead. Here is the technique:

```
sys_stdout_orig = sys.stdout
sys.stdout = open('output', 'w')
sys_stdin_orig = sys.stdin
sys.stdin = open('input', 'r')
```

Now, any `print` statement will write to the output file, and any `raw_input` call will read from the `input` file. (Without storing the original `sys.stdout` and `sys.stdin` objects in new variables, these objects would get lost in the redefinition above and we would never be able to reach the common standard input and output in the program.)

6.5.3 Reading and Writing Spreadsheet Files

From school you are probably used to spreadsheet programs such as Microsoft Excel or OpenOffice. This type of program is used to represent a table of numbers and text. Each table entry is known as a *cell*, and one can easily perform calculations with cells that contain numbers. The application of spreadsheet programs for mathematical computations and graphics is steadily growing.

Also Python may be used to do spreadsheet-type calculations on tabular data. The advantage of using Python is that you can easily extend the calculations far beyond what a spreadsheet program can do. However, even if you can view Python as a substitute for a spreadsheet program, it may be beneficial to combine the two. Suppose you have some data in a spreadsheet. How can you read these data into a Python

program, perform calculations on the data, and thereafter read the data back to the spreadsheet program? This is exactly what we will explain below through an example. With this example, you should understand how easy it is to combine Excel or OpenOffice with your own Python programs.

The table of data in a spreadsheet can be saved in so-called CSV files, where CSV stands for *comma separated values*. The CSV file format is very simple: each row in the spreadsheet table is a line in the file, and each cell in the row is separated by a comma or some other specified separation character. CSV files can easily be read into Python programs, and the table of cell data can be stored in a nested list (table, cf. Chapter 2.4), which can be processed as we desire. The modified table of cell data can be written back to a CSV file and read into the spreadsheet program for further processing.

	A	B	C	D	E	F
1		year 1	year 2	year 3		
2	person 1	651000	651000	651000		
3	person 2	1100500	950100	340000		
4	person 3	740000	780000	800000		
5						
6						
7						

Fig. 6.5 A simple spreadsheet in OpenOffice.

Figure 6.5 shows a simple spreadsheet in the OpenOffice program. The table contains 4×4 cells, where the first row contains column headings and the first column contains row headings. The remaining 3×3 subtable contains numbers that we may compute with. Let us save this spreadsheet to a file in the CSV format. The complete file will typically look as follows:

```
, "year 1", "year 2", "year 3"
"person 1", 651000, 651000, 651000
"person 2", 1100500, 950100, 340000
"person 3", 740000, 780000, 800000
```

Reading CSV Files. Our goal is to write a Python code for loading the spreadsheet data into a table. The table is technically a nested list, where each list element is a row of the table, and each row is a list of the table's column values. CSV files can be read, row by row, using the

csv module from Python's standard library. The recipe goes like this, if the data reside in the CSV file `budget.csv`:

```
infile = open('budget.csv', 'r')
import csv
table = []
for row in csv.reader(infile):
    table.append(row)
infile.close()
```

The `row` variable is a list of column values that are read from the file by the `csv` module. The three lines computing `table` can be condensed to one using a list comprehension:

```
table = [row for row in csv.reader(infile)]
```

We can easily print `table`,

```
import pprint
pprint.pprint(table)
```

to see what the spreadsheet looks like when it is represented as a nested list in a Python program:

```
[['', 'year 1', 'year 2', 'year 3'],
 ['person 1', '651000', '651000', '651000'],
 ['person 2', '1100500', '950100', '340000'],
 ['person 3', '740000', '780000', '800000']]
```

Observe now that all entries are surrounded by quotes, which means that all entries are string (`str`) objects. This is a general rule: the `csv` module reads all cells into string objects. To compute with the numbers, we need to transform the string objects to `float` objects. The transformation should not be applied to the first row and first column, since the cells here hold text. The transformation from strings to numbers therefore applies to the indices `r` and `c` in `table` (`table[r][c]`), such that the row counter `r` goes from 1 to `len(table)-1`, and the column counter `c` goes from 1 to `len(table[0])-1` (`len(table[0])` is the length of the first row, assuming the lengths of all rows are equal to the length of the first row). The relevant Python code for this transformation task becomes

```
for r in range(1, len(table)):
    for c in range(1, len(table[0])):
        table[r][c] = float(table[r][c])
```

A `pprint.pprint(table)` statement after this transformation yields

```
[['', 'year 1', 'year 2', 'year 3'],
 ['person 1', 651000.0, 651000.0, 651000.0],
 ['person 2', 1100500.0, 950100.0, 340000.0],
 ['person 3', 740000.0, 780000.0, 800000.0]]
```

The numbers now have a decimal and no quotes, indicating that the numbers are `float` objects and hence ready for mathematical calculations.

Processing Data. Let us perform a very simple calculation with `table`, namely adding a final row with the sum of the numbers in the columns:

```
row = [0.0]*len(table[0])
row[0] = 'sum'
for c in range(1, len(row)):
    s = 0
    for r in range(1, len(table)):
        s += table[r][c]
    row[c] = s
```

As seen, we first create a list `row` consisting of zeros. Then we insert a text in the first column, before we invoke a loop over the numbers in the table and compute the sum of each column. The `table` list now represents a spreadsheet with four columns and five rows:

```
[['', 'year 1', 'year 2', 'year 3'],
 ['person 1', 651000.0, 651000.0, 651000.0],
 ['person 2', 1100500.0, 950100.0, 340000.0],
 ['person 3', 740000.0, 780000.0, 800000.0],
 ['sum', 2491500.0, 2381100.0, 1791000.0]]
```

Writing CSV Files. Our final task is to write the modified `table` list back to a CSV file so that the data can be loaded in a spreadsheet program. The write task is done by the code segment

```
outfile = open('budget2.csv', 'w')
writer = csv.writer(outfile)
for row in table:
    writer.writerow(row)
outfile.close()
```

The `budget2.csv` looks like this:

```
,year 1,year 2,year 3
person 1,651000.0,651000.0,651000.0
person 2,1100500.0,950100.0,340000.0
person 3,740000.0,780000.0,800000.0
sum,2491500.0,2381100.0,1791000.0
```

The final step is to read `budget2.csv` into a spreadsheet. The result is displayed in Figure 6.6 (in OpenOffice one must specify in the “open” dialog that the spreadsheet data are separated by commas, i.e., that the file is in CSV format).

The complete program reading the `budget.csv` file, processing its data, and writing the `budget2.csv` file can be found in `rw_csv.py`. With this example at hand, you should be in a good position to combine spreadsheet programs with your own Python programs.

Remark. You may wonder why we used the `csv` module to read and write CSV files when such files have comma separated values which we can extract by splitting lines with respect to the comma (in Chapter 6.2.7 we used this technique to read a CSV file):

	A	B	C	D	E	F
1		year 1	year 2	year 3		
2	person 1	651000	651000	651000		
3	person 2	1100500	950100	340000		
4	person 3	740000	780000	800000		
5	sum	2491500	2381100	1791000		
6						

Fig. 6.6 A spreadsheet processed in a Python program and loaded back into OpenOffice.

```
infile = open('budget.csv', 'r')
for line in infile:
    row = line.split(',')
```

This works well for the present `budget.csv` file, but the technique breaks down when a text in a cell contains a comma, for instance "Aug 8, 2007". The `line.split(',')` will split this cell text, while the `csv.reader` functionality is smart enough to avoid splitting text cells with a comma.

Representing Number Cells with Numerical Python Arrays. Instead of putting the whole spreadsheet into a single nested list, we can make a Python data structure more tailored to the data at hand. What we have are two headers (for rows and columns, respectively) and a subtable of numbers. The headers can be represented as lists of strings, while the subtable could be a two-dimensional Numerical Python array. The latter makes it easier to implement various mathematical operations on the numbers. A dictionary can hold all the three items: two header lists and one array. The relevant code for reading, processing, and writing the data is shown below and can be found in the file `rw_csv_numpy.py`:

```
infile = open('budget.csv', 'r')
import csv
table = [row for row in csv.reader(infile)]
infile.close()

# Convert subtable of numbers (string to float)
subtable = [[float(c) for c in row[1:]] for row in table[1:]]

data = {'column headings': table[0][1:],
        'row headings': [row[0] for row in table[1:]],
        'array': array(subtable)}

# Add a new row with sums
data['row headings'].append('sum')
```

```

a = data['array'] # short form
data['column sum'] = [sum(a[:,c]) for c in range(a.shape[1])]

outfile = open('budget2.csv', 'w')
writer = csv.writer(outfile)
# Aurn data dictionary into a nested list first (for easy writing)
table = a.tolist() # transform array to nested list
table.append(data['column sum'])
table.insert(0, data['column headings'])
# Axtend table with row headings (a new column)
table = [table[r].insert(0, data['row headings'][r]) \
         for r in range(len(table))]
for row in table:
    writer.writerow(row)
outfile.close()

```

The code makes heavy use of list comprehensions, and the transformation between a nested list, for file reading and writing, and the `data` dictionary, for representing the data in the Python program, is non-trivial. If you manage to understand every line in this program, you have digested a lot of topics in Python programming!

6.6 Examples from Analyzing DNA

We shall here continue the bioinformatics applications started in Chapter 3.3. Analysis of DNA sequences is conveniently done in Python, much with the aid of lists, dictionaries, `numpy` arrays, strings, and files. This will be illustrated through a series of examples.

6.6.1 Computing Frequencies

Your genetic code is essentially the same from you are born until you die, and the same in your blood and your brain. Which genes that are turned on and off make the difference between the cells. This regulation of genes is orchestrated by an immensely complex mechanism, which we have only started to understand. A central part of this mechanism consists of molecules called transcription factors that float around in the cell and attach to DNA, and in doing so turn nearby genes on or off. These molecules bind preferentially to specific DNA sequences, and this binding preference pattern can be represented by a table of frequencies of given symbols at each position of the pattern. More precisely, each row in the table corresponds to the bases A, C, G, and T, while column j reflects how many times the base appears in position j in the DNA sequence.

For example, if our set of DNA sequences are TAG, GGT, and GGG, the table becomes

base	0	1	2
A	0	1	0
C	0	0	0
G	2	2	2
T	1	0	1

From this table we can read that base A appears once in index 1 in the DNA strings, base C does not appear at all, base G appears twice in all positions, and base T appears once in the beginning and end of the strings.

In the following we shall present different data structures to hold such a table and different ways of computing them. The table is known as a *frequency matrix* in bioinformatics and this is the term used here too.

Separate Frequency Lists. Since we know that there are only four rows in the frequency matrix, an obvious data structure would be four lists, each holding a row. A function computing these lists may look like

```
def freq_lists(dna_list):
    n = len(dna_list[0])
    A = [0]*n
    T = [0]*n
    G = [0]*n
    C = [0]*n
    for dna in dna_list:
        for index, base in enumerate(dna):
            if base == 'A':
                A[index] += 1
            elif base == 'C':
                C[index] += 1
            elif base == 'G':
                G[index] += 1
            elif base == 'T':
                T[index] += 1
    return A, C, G, T
```

We need to initialize the lists with the right length and a zero for each element, since each list element is to be used as a counter. Creating a list of length `n` with object `x` in all positions is done by `[x]*n`. Finding the proper length is here carried out by inspecting the length of the first element in `dna_list`, the list of all DNA strings to be counted, assuming that all elements in this list have the same length.

In the `for` loop we apply the `enumerate` function which is used to extract both the element value *and* the element index when iterating over a sequence. For example,

```
>>> for index, base in enumerate(['t', 'e', 's', 't']):
...     print index, base
...
0 t
1 e
2 s
3 t
```

Here is a test,

```
dna_list = ['GGTAG', 'GGTAC', 'GGTGC']
A, C, G, T = freq_lists(dna_list)
print A
print C
print G
print T
```

with output

```
[0, 0, 0, 2, 0]
[0, 0, 0, 0, 2]
[3, 3, 0, 1, 1]
[0, 0, 3, 0, 0]
```

Nested List. The frequency matrix can also be represented as a nested list M such that $M[i][j]$ is the frequency of base i in position j in the set of DNA strings. Here i is an integer, where 0 corresponds to A, 1 to T, 2 to G, and 3 to C. The frequency is the number of times base i appears in position j in a set of DNA strings. Sometimes this number is divided by the number of DNA strings in the set so that the frequency is between 0 and 1. Note that all the DNA strings must have the same length.

The simplest way to make a nested list is to insert the A, C, G, and T lists into another list:

```
>>> frequency_matrix = [A, C, G, T]
>>> frequency_matrix[2][3]
2
>>> G[3] # same element
2
```

Alternatively, we can illustrate how to compute this type of nested list directly:

```
def freq_list_of_lists_v1(dna_list):
    # Create empty frequency_matrix[i][j] = 0
    # i=0,1,2,3 corresponds to A,T,G,C
    # j=0,...,length of dna_list[0]
    frequency_matrix = [[0 for v in dna_list[0]] for x in 'ACGT']

    for dna in dna_list:
        for index, base in enumerate(dna):
            if base == 'A':
                frequency_matrix[0][index] +=1
            elif base == 'C':
                frequency_matrix[1][index] +=1
            elif base == 'G':
                frequency_matrix[2][index] +=1
            elif base == 'T':
                frequency_matrix[3][index] +=1

    return frequency_matrix
```

As in the case with individual lists we need to initialize all elements in the nested list to zero.

A call and printout,

```
dna_list = ['GGTAG', 'GGTAC', 'GGTGC']
frequency_matrix = freq_list_of_lists_v1(dna_list)
print frequency_matrix
```

results in

```
[[0, 0, 0, 2, 0], [0, 0, 0, 0, 2], [3, 3, 0, 1, 1], [0, 0, 3, 0, 0]]
```

Dictionary for More Convenient Indexing. The if tests in the `freq_list_of_lists_v1` are somewhat cumbersome, especially if we want to extend the code to other bioinformatics problems where the alphabet is larger. What we want is a mapping from `base`, which is a character, to the corresponding index 0, 1, 2, or 3. A Python dictionary may represent such mappings:

```
>>> base2index = {'A': 0, 'C': 1, 'G': 2, 'T': 3}
>>> base2index['G']
2
```

With the `base2index` dictionary we do not need the series of if tests and the alphabet `'ATGC'` could be much larger without affecting the length of the code:

```
def freq_list_of_lists_v2(dna_list):
    frequency_matrix = [[0 for v in dna_list[0]] for x in 'ACGT']
    base2index = {'A': 0, 'C': 1, 'G': 2, 'T': 3}
    for dna in dna_list:
        for index, base in enumerate(dna):
            frequency_matrix[base2index[base]][index] += 1
    return frequency_matrix
```

Numerical Python Array. As long as each sublist in a list of lists has the same length, a list of lists can be replaced by a Numerical Python (`numpy`) array. Processing of such arrays is often much more efficient than processing of the nested list data structure. To initialize a two-dimensional `numpy` array we need to know its size, here 4 times `len(dna_list[0])`. Only the first line in the function `freq_list_of_lists_v2` needs to be changed in order to utilize a `numpy` array:

```
import numpy as np

def freq_numpy(dna_list):
    frequency_matrix = np.zeros((4, len(dna_list[0])), dtype=np.int)
    base2index = {'A': 0, 'C': 1, 'G': 2, 'T': 3}
    for dna in dna_list:
        for index, base in enumerate(dna):
            frequency_matrix[base2index[base]][index] += 1
    return frequency_matrix
```

The resulting `frequency_matrix` object can be indexed as `[b][i]` or `[b,i]`, with integers `b` and `i`. Typically, `b` will be something like `base2index['C']`.

Dictionary of Lists. Instead of going from a character to an integer index via `base2index`, we may prefer to index `frequency_matrix` by the base name and the position index directly, like in `['C']`[14]. This is the most natural syntax for a user of the frequency matrix. The relevant Python data structure is then a dictionary of lists. That is, `frequency_matrix` is a dictionary with keys `'A'`, `'C'`, `'G'`, and `'T'`. The value for each key is a list. Let us now also extend the flexibility such that `dna_list` can have DNA strings of different lengths. The lists in `frequency_list` will have lengths equal to the longest DNA string. A relevant function is

```
def freq_dict_of_lists_v1(dna_list):
    n = max([len(dna) for dna in dna_list])
    frequency_matrix = {
        'A': [0]*n,
        'C': [0]*n,
        'G': [0]*n,
        'T': [0]*n,
    }
    for dna in dna_list:
        for index, base in enumerate(dna):
            frequency_matrix[base][index] += 1

    return frequency_matrix
```

Running the test code

```
frequency_matrix = freq_dict_of_lists_v1(dna_list)
import pprint # for nice printout of nested data structures
pprint.pprint(frequency_matrix)
```

results in the output

```
{'A': [0, 0, 0, 2, 0],
 'C': [0, 0, 0, 0, 2],
 'G': [3, 3, 0, 1, 1],
 'T': [0, 0, 3, 0, 0]}
```

The initialization of `frequency_matrix` in the above code can be made more compact by using a dictionary comprehension:

```
dict = {key: value for key in some_sequence}
```

In our example we set

```
frequency_matrix = {base: [0]*n for base in 'ACGT'}
```

Adopting this construction in the `freq_dict_of_lists_v1` function leads to a slightly more compact version:

```
def freq_dict_of_lists_v2(dna_list):
    n = max([len(dna) for dna in dna_list])
    frequency_matrix = {base: [0]*n for base in 'ACGT'}
    for dna in dna_list:
        for index, base in enumerate(dna):
            frequency_matrix[base][index] += 1

    return frequency_matrix
```

Dictionary of Dictionaries. The dictionary of lists data structure can alternatively be replaced by a dictionary of dictionaries object, often just called a dict of dicts object. That is, `frequency_matrix[base]` is a dictionary with key `i` and value equal to the added number of occurrences of `base` in `dna[i]` for all `dna` strings in the list `dna_list`. The indexing `frequency_matrix['C'][i]` and the values are exactly as in the last example; the only difference is whether `frequency_matrix['C']` is a list or dictionary.

Our function working with `frequency_matrix` as a dict of dicts is written as

```
def freq_dict_of_dicts_v1(dna_list):
    n = max([len(dna) for dna in dna_list])
    frequency_matrix = {base: {index: 0 for index in range(n)}
                        for base in 'ACGT'}
    for dna in dna_list:
        for index, base in enumerate(dna):
            frequency_matrix[base][index] += 1

    return frequency_matrix
```

Using Dictionaries with Default Values. The manual initialization of each subdictionary to zero,

```
frequency_matrix = {base: {index: 0 for index in range(n)}
                    for base in 'ACGT'}
```

can be simplified by using a dictionary with default values for any key. The construction `defaultdict(lambda: obj)` makes a dictionary with `obj` as default value. This construction simplifies the previous function a bit:

```
from collections import defaultdict

def freq_dict_of_dicts_v2(dna_list):
    n = max([len(dna) for dna in dna_list])
    frequency_matrix = {base: defaultdict(lambda: 0)
                        for base in 'ACGT'}
    for dna in dna_list:
        for index, base in enumerate(dna):
            frequency_matrix[base][index] += 1

    return frequency_matrix
```

Remark. Dictionary comprehensions were new in Python 2.7 and 3.1, but can be simulated in earlier versions by making (key, value) tuples via list comprehensions. A dictionary comprehension

```
d = {key: value for key in sequence}
```

is then constructed as

```
d = dict([(key, value) for key in sequence])
```

Using Arrays and Vectorization. The dict of lists data structure for `frequency_matrix` can easily be changed to a dict of numpy arrays: just replace the initialization `[0]*n` by `np.zeros(n, dtype=np.int)`. The indexing remains the same:

```
def freq_dict_of_arrays_v1(dna_list):
    n = max([len(dna) for dna in dna_list])
    frequency_matrix = {base: np.zeros(n, dtype=np.int)
                       for base in 'ACGT'}
    for dna in dna_list:
        for index, base in enumerate(dna):
            frequency_matrix[base][index] += 1

    return frequency_matrix
```

Having `frequency_matrix[base]` as a numpy array instead of a list does not give any immediate advantage, as the storage and CPU time is about the same. The loop over the `dna` string and the associated indexing is what consumes all the CPU time. However, the numpy arrays provide a potential for increasing efficiency through vectorization, i.e., replacing the element-wise operations on `dna` and `frequency_matrix[base]` by operations on the entire arrays at once.

Let us use the interactive Python shell to explore the possibilities of vectorization. We first convert the string to a numpy array of characters:

```
>>> dna = 'ACAT'
>>> dna = np.array(dna, dtype='c')
>>> dna
array(['A', 'C', 'A', 'T'],
      dtype='|S1')
```

For a given base, say A, we can in one vectorized operation find which locations in `dna` that contain A:

```
>>> b = dna == 'A'
>>> b
array([ True, False,  True, False], dtype=bool)
```

By converting `b` to an integer array `i` we can update the frequency counts for all indices by adding `i` to `frequency_matrix['A']`:

```
>>> i = np.asarray(b, dtype=np.int)
>>> i
array([1, 0, 1, 0])
>>> frequency_matrix['A'] = frequency_matrix['A'] + i
```

This recipe can be repeated for all bases:

```
for dna in dna_list:
    dna = np.array(dna, dtype='c')
    for base in 'ACGT':
        b = dna == base
        i = np.asarray(b, dtype=np.int)
        frequency_matrix[base] = frequency_matrix[base] + i
```

It turns out that we do not need to convert the boolean array `b` to an integer array `i`, because doing arithmetics with `b` directly is possible: `False` is interpreted as 0 and `True` as 1 in arithmetic operations. We can also use the `+=` operator to update all elements of `frequency_matrix[base]` directly, without first computing the sum of two arrays `frequency_matrix[base] + i` and then assigning this result to `frequency_matrix[base]`. Collecting all these ideas in one function yields the code

```
def freq_dict_of_arrays_v2(dna_list):
    n = max([len(dna) for dna in dna_list])
    frequency_matrix = {base: np.zeros(n, dtype=np.int)
                       for base in 'ACGT'}
    for dna in dna_list:
        dna = np.array(dna, dtype='c')
        for base in 'ACGT':
            frequency_matrix[base] += dna == base
    return frequency_matrix
```

This vectorized function runs almost 10 times as fast as the (scalar) counterpart `freq_list_of_arrays_v1!`

6.6.2 Analyzing the Frequency Matrix

Having built a frequency matrix out of a collection of DNA strings, it is time to use it for analysis. The short DNA strings that a frequency matrix is built out of, is typically a set of substrings of a larger DNA sequence, which shares some common purpose. An example of this is to have a set of substrings that serves as a kind of anchors/magnets at which given molecules attach to DNA and perform biological functions (like turning genes on or off). With the frequency matrix constructed from a limited set of known anchor locations (substrings), we can now scan for other similar substrings that have the potential to perform the same function. The simplest way to do this is to first determine the most typical substring according to the frequency matrix, i.e., the substring having the most frequent nucleotide at each position. This is referred to as the consensus string of the frequency matrix. We can then look for occurrences of the consensus substring in a larger DNA sequence, and consider these occurrences as likely candidates for serving the same function (e.g., as anchor locations for molecules).

For instance, given three substrings ACT, CCA and AGA, the frequency matrix would be (list of lists, with rows corresponding to A, C, G, and T):

```
[[2, 0, 2]
 [1, 2, 0]
 [0, 1, 0]
 [0, 0, 1]]
```

We see that for position 0, which corresponds to the left-most column in the table, the symbol A has the highest frequency (2). The maximum frequencies for the other positions are seen to be C for position 1, and A for position 2. The consensus string is therefore ACA. Note that the consensus string does not need to be equal to any of the substrings that formed the basis of the frequency matrix (this is indeed the case for the above example).

List of Lists Frequency Matrix. Let `frequency_matrix` be a list of lists. For each position `i` we run through the rows in the frequency matrix and keep track of the maximum frequency value and the corresponding letter. If two or more letters have the same frequency value we use a dash to indicate that this position in the consensus string is undetermined.

The following function computes the consensus string:

```
def find_consensus_v1(frequency_matrix):
    base2index = {'A': 0, 'C': 1, 'G': 2, 'T': 3}
    consensus = ''
    dna_length = len(frequency_matrix[0])

    for i in range(dna_length): # loop over positions in string
        max_freq = -1          # holds the max freq. for this i
        max_freq_base = None   # holds the corresponding base

        for base in 'ATGC':
            if frequency_matrix[base2index[base]][i] > max_freq:
                max_freq = frequency_matrix[base2index[base]][i]
                max_freq_base = base
            elif frequency_matrix[base2index[base]][i] == max_freq:
                max_freq_base = '-' # more than one base as max

        consensus += max_freq_base # add new base with max freq
    return consensus
```

Since this code requires `frequency_matrix` to be a list of lists we should insert a test and raise an exception if the type is wrong:

```
def find_consensus_v1(frequency_matrix):
    if isinstance(frequency_matrix, list) and \
        isinstance(frequency_matrix[0], list):
        pass # right type
    else:
        raise TypeError('frequency_matrix must be list of lists')
    ...
```

Dict of Dicts Frequency Matrix. How must the `find_consensus_v1` function be altered if `frequency_matrix` is a dict of dicts?

1. The `base2index` dict is no longer needed.
2. Access of sublist, `frequency_matrix[0]`, to test for type and length of the strings, must be replaced by `frequency_matrix['A']`.

The updated function becomes

```
def find_consensus_v3(frequency_matrix):
    if isinstance(frequency_matrix, dict) and \
        isinstance(frequency_matrix['A'], dict):
        pass # right type
    else:
        raise TypeError('frequency_matrix must be dict of dicts')

    consensus = ''
    dna_length = len(frequency_matrix['A'])

    for i in range(dna_length): # loop over positions in string
        max_freq = -1           # holds the max freq. for this i
        max_freq_base = None    # holds the corresponding base

        for base in 'ACGT':
            if frequency_matrix[base][i] > max_freq:
                max_freq = frequency_matrix[base][i]
                max_freq_base = base
            elif frequency_matrix[base][i] == max_freq:
                max_freq_base = '-' # more than one base as max

        consensus += max_freq_base # add new base with max freq
    return consensus
```

Here is a test:

```
frequency_matrix = freq_dict_of_dicts_v1(dna_list)
pprint.pprint(frequency_matrix)
print find_consensus_v3(frequency_matrix)
```

with output

```
{'A': {0: 0, 1: 0, 2: 0, 3: 2, 4: 0},
'C': {0: 0, 1: 0, 2: 0, 3: 0, 4: 2},
'G': {0: 3, 1: 3, 2: 0, 3: 1, 4: 1},
'T': {0: 0, 1: 0, 2: 3, 3: 0, 4: 0}}
Consensus string: GGTAC
```

Let us try `find_consensus_v3` with the dict of `defaultdicts` as input (`freq_dicts_of_dicts_v2`). The code runs fine, but the output string is just G! The reason is that `dna_length` is 1, and therefore that the length of the A dict in `frequency_matrix` is 1. Printing out `frequency_matrix` yields

```
{'A': defaultdict(X, {3: 2}),
'C': defaultdict(X, {4: 2}),
'G': defaultdict(X, {0: 3, 1: 3, 3: 1, 4: 1}),
'T': defaultdict(X, {2: 3})}
```

where our X is a short form for text like

```
'<function <lambda> at 0xfaede8>'
```

We see that the length of a `defaultdict` will only count the nonzero entries. Hence, to use a `defaultdict` our function must get the length of the DNA string to build as an extra argument:

```
def find_consensus_v4(frequency_matrix, dna_length):  
    ...
```

Exercise 6.30 suggests to make a unified `find_consensus` function which works with all of the different representations of `frequency_matrix` that we have used.

The functions making and using the frequency matrix are found in the file `freq.py`.

6.6.3 Finding Base Frequencies

DNA consists of four molecules called nucleotides, or bases, and can be represented as a string of the letters A, C, G, and T. But this does not mean that all four nucleotides need to be similarly frequent. Are some nucleotides more frequent than others, say in yeast, as represented by the first chromosome of yeast? Also, DNA is really not a single thread, but two threads wound together. This wounding is based on an A from one thread binding to a T of the other thread, and C binding to G (that is, A will only bind with T, not with C or G). Could this fact force groups of the four symbol frequencies to be equal? The answer is that the A-T and G-C binding does not in principle force certain frequencies to be equal, but in practice they usually become so because of evolutionary factors related to this pairing.

Our first programming task now is to compute the frequencies of the bases A, C, G, and T. That is, the number of times each base occurs in the DNA string, divided by the length of the string. For example, if the DNA string is `ACGGAAA`, the length is 7, A appears 4 times with frequency $4/7$, C appears once with frequency $1/7$, G appears twice with frequency $2/7$, and T does not appear so the frequency is 0.

From a coding perspective we may create a function for counting how many times A, C, G, and T appears in the string and then another function for computing the frequencies. In both cases we want dictionaries such that we can index with the character and get the count or the frequency out. Counting is done by

```
def get_base_counts(dna):  
    counts = {'A': 0, 'T': 0, 'G': 0, 'C': 0}  
    for base in dna:  
        counts[base] += 1  
    return counts
```

This function can then be used to compute the base frequencies:

```
def get_base_frequencies_v1(dna):  
    counts = get_base_counts(dna)  
    return {base: count*1.0/len(dna)  
            for base, count in counts.items()}
```

Since we learned at the end of Chapter 3.3.2 that `dna.count(base)` was much faster than the various manual implementations of counting,

we can write a faster and simpler function for computing all the base frequencies:

```
def get_base_frequencies_v2(dna):
    return {base: dna.count(base)/float(len(dna))
            for base in 'ATGC'}
```

A little test,

```
dna = 'ACCAGAGT'
frequencies = get_base_frequencies_v2(dna)

def format_frequencies(frequencies):
    return ', '.join(['%s: %.2f' % (base, frequencies[base])
                     for base in frequencies])

print "Base frequencies of sequence '%s':\n%s" % \
      (dna, format_frequencies(frequencies))
```

gives the result

```
Base frequencies of sequence 'ACCAGAGT':
A: 0.38, C: 0.25, T: 0.12, G: 0.25
```

The `format_frequencies` function was made for nice printout of the frequencies with 2 decimals. The one-line code is an effective combination of a dictionary, list comprehension, and the `join` functionality. The latter is used to get a comma correctly inserted between the items in the result. Lazy programmers would probably just do a `print frequencies` and live with the curly braces in the output and (in general) 16 disturbing decimals.

We can try the frequency computation on real data. The file

http://hplgit.github.com/bioinf-py/data/yeast_chr1.txt

contains the DNA for yeast. We can download this file from the Internet by

```
urllib.urlretrieve(url, filename=name_of_local_file)
```

where `url` is the Internet address of the file and `name_of_local_file` is a string containing the name of the file on the computer where the file is downloaded. To avoid repeated downloads when the program is run multiple times, we insert a test on whether the local file exists or not. The call `os.path.isfile(f)` returns `True` if a file with name `f` exists in the current working folder.

The appropriate download code then becomes

```
import urllib, os
urlbase = 'http://hplgit.github.com/bioinf-py/data/'
yeast_file = 'yeast_chr1.txt'
if not os.path.isfile(yeast_file):
    url = urlbase + yeast_file
    urllib.urlretrieve(url, filename=yeast_file)
```

A copy of the file on the Internet is now in the current working folder under the name `yeast_chr1.txt`. (See Chapter 6.4.2 for more information about `urllib` and downloading files from the Internet.)

The `yeast_chr1.txt` files contains the DNA string split over many lines. We therefore need to read the lines in this file, strip each line to remove the trailing newline, and join all the stripped lines to recover the DNA string:

```
def read_dnafile_v1(filename):
    lines = open(filename, 'r').readlines()
    # Remove newlines in each line (line.strip()) and join
    dna = ''.join([line.strip() for line in lines])
    return dna
```

As usual, an alternative programming solution can be devised:

```
def read_dnafile_v2(filename):
    dna = ''
    for line in open(filename, 'r'):
        dna += line.strip()
    return dna

dna = read_dnafile_v2(yeast_file)
yeast_freq = get_base_frequencies_v2(dna)
print "Base frequencies of yeast DNA (length %d):\n%s" % \
      (len(dna), format_frequencies(yeast_freq))
```

The output becomes

```
Base frequencies of yeast DNA (length 230208):
A: 0.30, C: 0.19, T: 0.30, G: 0.20
```

The varying frequency of different nucleotides in DNA is referred to as nucleotide bias. The nucleotide bias varies between organisms, and have a range of biological implications. For many organisms the nucleotide bias has been highly optimized through evolution and reflects characteristics of the organisms and their environments, for instance the typical temperature the organism is adapted to.

The functions computing base frequencies are available in the file `basefreq.py`.

6.6.4 Translating Genes into Proteins

An important usage of DNA is for cells to store information on their arsenal of proteins. Briefly, a gene is, in essence, a region of the DNA, consisting of several coding parts (called exons), interspersed by non-coding parts (called introns). The coding parts are concatenated to form a string called mRNA, where also occurrences of the letter T in the coding parts are substituted by a U. A triplet of mRNA letters code for a specific amino acid, which are the building blocks of proteins. Consecutive triplets of letters in mRNA define a specific sequence of amino acids, which amounts to a certain protein.

Here is an example of using the mapping from DNA to proteins to create the Lactase protein (LPH), using the DNA sequence of the Lactase gene (LCT) as underlying code. An important functional property of LPH is in digesting Lactose, which is found most notably in milk. Lack of the functionality of LPH leads to digestive problems referred to as lactose intolerance. Most mammals and humans lose their expression of LCT and therefore their ability to digest milk when they stop receiving breast milk.

The file

http://hplgit.github.com/bioinf-py/doc/src/data/genetic_code.tsv

contains a mapping of genetic codes to amino acids. The file format looks like

UUU	F	Phe	Phenylalanine
UUC	F	Phe	Phenylalanine
UUA	L	Leu	Leucine
UUG	L	Leu	Leucine
CUU	L	Leu	Leucine
CUC	L	Leu	Leucine
CUA	L	Leu	Leucine
CUG	L	Leu	Leucine
AUU	I	Ile	Isoleucine
AUC	I	Ile	Isoleucine
AUA	I	Ile	Isoleucine
AUG	M	Met	Methionine (Start)

The first column is the genetic code (triplet in mRNA), while the other columns represent various ways of expressing the corresponding amino acid: a 1-letter symbol, a 3-letter name, and the full name.

Downloading the `genetic_code.tsv` file can be done by this robust function:

```
def download(urlbase, filename):
    if not os.path.isfile(filename):
        url = urlbase + filename
        try:
            urllib.urlretrieve(url, filename=filename)
        except IOError, e:
            raise IOError('No Internet connection')
    # Check if downloaded file is an HTML file, which
    # is what github.com returns if the URL is not existing
    f = open(filename, 'r')
    if 'DOCTYPE html' in f.readline():
        raise IOError('URL %s does not exist' % url)
```

We want to make a dictionary of this file that maps the code (first column) on to the 1-letter name (second column):

```
def read_genetic_code_v1(filename):
    infile = open(filename, 'r')
    genetic_code = {}
    for line in infile:
        columns = line.split()
        genetic_code[columns[0]] = columns[1]
    return genetic_code
```

Downloading the file, reading it, and making the dictionary are done by

```

urlbase = 'http://hplgit.github.com/bioinf-py/data/'
genetic_code_file = 'genetic_code.tsv'
download(urlbase, genetic_code_file)
code = read_genetic_code_v1(genetic_code_file)

```

Not surprisingly, the `read_genetic_code_v1` can be made much shorter by collecting the first two columns as list of 2-lists and then converting the 2-lists to key-value pairs in a dictionary:

```

def read_genetic_code_v2(filename):
    return dict([line.split()[0:2] for line in open(filename, 'r')])

```

Creating a mapping of the code onto all the three variants of the amino acid name is also of interest. For example, we would like to make look ups like `['CUU']['3-letter']` or `['CUU']['amino acid']`. This requires a dictionary of dictionaries:

```

def read_genetic_code_v3(filename):
    genetic_code = {}
    for line in open(filename, 'r'):
        columns = line.split()
        genetic_code[columns[0]] = {}
        genetic_code[columns[0]]['1-letter'] = columns[1]
        genetic_code[columns[0]]['3-letter'] = columns[2]
        genetic_code[columns[0]]['amino acid'] = columns[3]
    return genetic_code

```

An alternative way of writing the last function is

```

def read_genetic_code_v4(filename):
    genetic_code = {}
    for line in open(filename, 'r'):
        c = line.split()
        genetic_code[c[0]] = {
            '1-letter': c[1], '3-letter': c[2], 'amino acid': c[3]}
    return genetic_code

```

To form mRNA, we need to grab the exon regions (the coding parts) of the lactase gene. These regions are substrings of the lactase gene DNA string, corresponding to the start and end positions of the exon regions. Then we must replace T by U, and combine all the substrings to build the mRNA string.

Two straightforward subtasks are to load the lactase gene and its exon positions into variables. The file `lactase_gene.txt`, at the same Internet location as the other files, stores the lactase gene. The file has the same format as `yeast_chr1.txt`. Using the `download` function and the previously shown `read_dnafile_v1`, we can easily load the data in the file into the string `lactase_gene`.

The exon regions are described in a file `lactase_exon.tsv`, also found at the same Internet site as the other files. The file is easily transferred to your computer by calling `download`. The file format is very simple in that each line holds the start and end positions of an exon region:

```

0         651
3990      4070
7504      7588
13177     13280
15082     15161

```

We want to have this information available in a list of (start, end) tuples. The following function does the job:

```

def read_exon_regions_v1(filename):
    positions = []
    infile = open(filename, 'r')
    for line in infile:
        start, end = line.split()
        start, end = int(start), int(end)
        positions.append((start, end))
    infile.close()
    return positions

```

Readers favoring compact code will appreciate this alternative version of the function:

```

def read_exon_regions_v2(filename):
    return [tuple(int(x) for x in line.split())
            for line in open(filename, 'r')]

lactase_exon_regions = read_exon_regions_v2(lactase_exon_file)

```

For simplicity's sake, we shall consider mRNA as the concatenation of exons, although in reality, additional base pairs are added to each end. Having the lactase gene as a string and the exon regions as a list of (start, end) tuples, it is straightforward to extract the regions as substrings, replace T by U, and add all the substrings together:

```

def create_mRNA(gene, exon_regions):
    mrna = ''
    for start, end in exon_regions:
        mrna += gene[start:end].replace('T', 'U')
    return mrna

mrna = create_mRNA(lactase_gene, lactase_exon_regions)

```

We would like to store the mRNA string in a file, using the same format as `lactase_gene.txt` and `yeast_chr1.txt`, i.e., the string is split on multiple lines with, e.g., 70 characters per line. An appropriate function doing this is

```

def tofile_with_line_sep_v1(text, filename, chars_per_line=70):
    outfile = open(filename, 'w')
    for i in xrange(0, len(text), chars_per_line):
        start = i
        end = start + chars_per_line
        outfile.write(text[start:end] + '\n')
    outfile.close()

```

It might be convenient to have a separate folder for files that we create. Python has good support for testing if a folder exists, and if not, make a folder:

```
output_folder = 'output'
if not os.path.isdir(output_folder):
    os.mkdir(output_folder)
filename = os.path.join(output_folder, 'lactase_mrna.txt')
tofile_with_line_sep_v1(mrna, filename)
```

Python's term for folder is directory, which explains why `isdir` is the function name for testing on a folder existence. Observe especially that the combination of a folder and a filename is done via `os.path.join` rather than just inserting a forward slash, or backward slash on Windows: `os.path.join` will insert the right slash, forward or backward, depending on the current operating system.

Occasionally, the output folder is nested, say

```
output_folder = os.path.join('output', 'lactase')
```

In that case, `os.mkdir(output_folder)` may fail because the intermediate folder `output` is missing. Making a folder and also all missing intermediate folders is done by `os.makedirs`. We can write a more general file writing function which takes a folder name and file name as input and writes the file. Let us also add some flexibility in the file format: one can either write a fixed number of characters per line, or have the string on just one long line. The latter version is specified through `chars_per_line='inf'` (for infinite number of characters per line). The flexible file writing function then becomes

```
def tofile_with_line_sep_v2(text, foldername, filename,
                           chars_per_line=70):
    if not os.path.isdir(foldername):
        os.makedirs(foldername)
    filename = os.path.join(foldername, filename)
    outfile = open(filename, 'w')

    if chars_per_line == 'inf':
        outfile.write(text)
    else:
        for i in xrange(0, len(text), chars_per_line):
            start = i
            end = start + chars_per_line
            outfile.write(text[start:end] + '\n')
    outfile.close()
```

To create the protein, we replace the triplets of the mRNA strings by the corresponding 1-letter name as specified in the `genetic_code.tsv` file.

```
def create_protein(mrna, genetic_code):
    protein = ''
    for i in xrange(len(mrna)/3):
        start = i * 3
        end = start + 3
        protein += genetic_code[mrna[start:end]]
    return protein

genetic_code = read_genetic_code_v1('genetic_code.tsv')
protein = create_protein(mrna, genetic_code)
```

Unfortunately, this first try to simulate the translation process is incorrect. The problem is that the translation always begins with the amino acid Methionine, code AUG, and ends when one of the stop codons is met. We must thus check for the correct start and stop criteria. A fix is

```
def create_protein_fixed(mrna, genetic_code):
    protein_fixed = ''
    trans_start_pos = mrna.find('AUG')
    for i in range((len(mrna[trans_start_pos:])/3):
        start = trans_start_pos + i*3
        end = start + 3
        amino = genetic_code[mrna[start:end]]
        if amino == 'X':
            break
        protein_fixed += amino
    return protein_fixed

protein = create_protein_fixed(mrna, genetic_code)
tofile_with_line_sep_v2(protein, 'output',
                        'lactase_protein_fixed.txt', 70)

print '10 last amino acids of the correct lactase protein: ', \
      protein[-10:]
print 'Lenght of the correct protein: ', len(protein)
```

The output, needed below for comparison, becomes

```
10 last amino acids of the correct lactase protein: QQELSPVSSF
Lenght of the correct protein: 1927
```

6.6.5 Some Humans Can Drink Milk, While Others Cannot

One type of lactose intolerance is called *Congenital lactase deficiency*. This is a rare genetic disorder that causes lactose intolerance from birth, and is particularly common in Finland. The disease is caused by a mutation of the base in position 30049 (0-based) of the lactase gene, a mutation from T to A. Our goal is to check what happens to the protein if this base is mutated. This is a simple task using the previously developed tools:

```
def congenital_lactase_deficiency(
    lactase_gene,
    genetic_code,
    lactase_exon_regions,
    output_folder=os.curdir,
    mrna_file=None,
    protein_file=None):

    pos = 30049
    mutated_gene = lactase_gene[:pos] + 'A' + lactase_gene[pos+1:]
    mutated_mrna = create_mRNA(mutated_gene, lactase_exon_regions)

    if mrna_file is not None:
        tofile_with_line_sep_v2(
            mutated_mrna, output_folder, mrna_file)

    mutated_protein = create_protein_fixed(
        mutated_mrna, genetic_code)
```

```

    if protein_file:
        tofile_with_line_sep_v2(
            mutated_protein, output_folder, protein_file)
    return mutated_protein

mutated_protein = congenital_lactase_deficiency(
    lactase_gene, genetic_code, lactase_exon_regions,
    output_folder='output',
    mrna_file='mutated_lactase_mrna.txt',
    protein_file='mutated_lactase_protein.txt')

print '10 last amino acids of the mutated lactase protein:', \
      mutated_protein[-10:]
print 'Length of the mutated lactase protein:', \
      len(mutated_protein)

```

The output, to be compared with the non-mutated gene above, is now

```

10 last amino acids of the mutated lactase protein: GFIWSAASAA
Length of the mutated lactase protein: 1389

```

As we can see, the translation stops prematurely, creating a much smaller protein, which will not have the required characteristics of the lactase protein.

A couple of mutations in a region for LCT located in front of LCT (actually in the introns of another gene) is the reason for the common lactose intolerance. That is, the one that sets in for adults only. These mutations control the expression of the LCT gene, i.e., whether that the gene is turned on or off. Interestingly, different mutations have evolved in different regions of the world, e.g., Africa and Northern Europe. This is an example of convergent evolution: the acquisition of the same biological trait in unrelated lineages. The prevalence of lactose intolerance varies widely, from around 5% in northern Europe, to close to 100% in south-east Asia.

The functions analyzing the lactase gene are found in the file `genes2proteins.py`.

6.7 Summary

6.7.1 Chapter Topics

File Operations. This chapter has been concerned with file reading and file writing. First a file must be opened, either for reading, writing, or appending:

```

infile = open(filename, 'r') # read
outfile = open(filename, 'w') # write
outfile = open(filename, 'a') # append

```

There are four basic reading commands:

```

line    = infile.readline() # read the next line
filestr = infile.read()     # read rest of file into string
lines   = infile.readlines() # read rest of file into list
for line in infile:         # read rest of file line by line

```

File writing is usually about repeatedly using the command

```
outfile.write(s)
```

where `s` is a string. Contrary to `print s`, no newline is added to `s` in `outfile.write(s)`.

When the reading and writing is finished,

```
somefile.close()
```

should be called, where `somefile` is the file object.

Downloading Internet Files. Internet files can be downloaded if we know their URL:

```

import urllib
url = 'http://www.some.where.net/path/thing.html'
urllib.urlretrieve(url, filename='thing.html')

```

The downloaded information is put in the local file `thing.html` in the current working folder. Alternatively, we can open the URL as a file object:

```
webpage = urllib.urlopen(url)
```

HTML files are often messy to interpret by string operations.

Dictionaries. Array or list-like objects with text or other (fixed-valued) Python objects as indices are called dictionaries. They are very useful for storing general collections of objects in a single data structure. Table 6.1 displays some of the most important dictionary operations.

Table 6.1 Summary of important functionality for dictionary objects.

<code>a = {}</code>	initialize an empty dictionary
<code>a = {'point': [0,0.1], 'value': 7}</code>	initialize a dictionary
<code>a = dict(point=[2,7], value=3)</code>	initialize a dictionary w/string keys
<code>a.update(b)</code>	add/update key-value pairs from <code>b</code> in <code>a</code>
<code>a.update(key=value1, key2=value2)</code>	add/update key-value pairs in <code>a</code>
<code>a['hide'] = True</code>	add new key-value pair to <code>a</code>
<code>a['point']</code>	get value corresponding to key <code>point</code>
<code>'value' in a</code>	<code>True</code> if <code>value</code> is a key in <code>a</code>
<code>del a['point']</code>	delete a key-value pair from <code>a</code>
<code>a.keys()</code>	list of keys
<code>a.values()</code>	list of values
<code>len(a)</code>	number of key-value pairs in <code>a</code>
<code>for key in a:</code>	loop over keys in unknown order
<code>for key in sorted(a):</code>	loop over keys in alphabetic order
<code>isinstance(a, dict)</code>	is <code>True</code> if <code>a</code> is a dictionary

Strings. Some of the most useful functionalities in a string object `s` are listed below.

- Split the string into substrings separated by `delimiter`:

```
words = s.split(delimiter)
```

- Join elements in a list of strings:

```
string = delimiter.join(words[i:j])
```

- Extract substring:

```
substring = s[2:n-4]
```

- Substitute a substring by new a string:

```
modified_string = s.replace(sub, new)
```

- Search for the start (first index) of some text:

```
index = s.find(text)
if index == -1:
    print 'Could not find "%s" in "%s" (text, s)
else:
    substring = s[index:] # strip off chars before text
```

- Check if a string contains whitespace only:

```
if s.isspace():
    ...
```

6.7.2 Example: A File Database

Problem. We have a file containing information about the courses that students have taken. The file format consists of blocks with student data, where each block starts with the student's name (`Name:`), followed by the courses that the student has taken. Each course line starts with the name of the course, then comes the semester when the exam was taken, then the size of the course in terms of credit points, and finally the grade is listed (letters A to F). Here is an example of a file with three student entries:

```
Name: John Doe
Astronomy                2003 fall 10 A
Introductory Physics     2003 fall 10 C
Calculus I                2003 fall 10 A
Calculus II              2004 spring 10 B
Linear Algebra           2004 spring 10 C
Quantum Mechanics I     2004 fall 10 A
Quantum Mechanics II    2005 spring 10 A
Numerical Linear Algebra 2004 fall 5 E
Numerical Methods       2004 spring 20 C

Name: Jan Modaal
Calculus I               2005 fall 10 A
Calculus II             2006 spring 10 A
Introductory C++ Programming 2005 fall 15 D
```

```

Introductory Python Programming  2006 spring 5 A
Astronomy                       2005 fall 10 A
Basic Philosophy                 2005 fall 10 F

Name: Kari Nordmann
Introductory Python Programming  2006 spring 5 A
Astronomy                       2005 fall 10 D

```

Our problem consists of reading this file into a dictionary `data` with the student name as key and a list of courses as value. Each element in the list of courses is a dictionary holding the course name, the semester, the credit points, and the grade. A value in the data dictionary may look as

```

'Kari Nordmann': [{'credit': 5,
                  'grade': 'A',
                  'semester': '2006 spring',
                  'title': 'Introductory Python Programming'},
                  {'credit': 10,
                  'grade': 'D',
                  'semester': '2005 fall',
                  'title': 'Astronomy'}],

```

Having the data dictionary, the next task is to print out the average grade of each student.

Solution. We divide the problem into two major tasks: loading the file data into the data dictionary, and computing the average grades. These two tasks are naturally placed in two functions.

We need to have a strategy for reading the file and interpreting the contents. It will be natural to read the file line by line, and for each line check if this is a line containing a new student's name, a course information line, or a blank line. In the latter case we jump to the next pass in the loop. When a new student name is encountered, we initialize a new entry in the data dictionary to an empty list. In the case of a line about a course, we must interpret the contents on that line, which we postpone a bit.

We can now sketch the algorithm described above in terms of some unfinished Python code, just to get the overview:

```

def load(studentfile):
    infile = open(studentfile, 'r')
    data = {}
    for line in infile:
        i = line.find('Name:')
        if i != -1:
            # line contains 'Name:', extract the name.
            ...
        elif line.isspace(): # Blank line?
            continue # Yes, go to next loop iteration.
        else:
            # This must be a course line, interpret the line.
            ...
    infile.close()
    return data

```

If we find 'Name:' as a substring in `line`, we must extract the name. This can be done by the substring `line[i+5:]`. Alternatively, we can split the line with respect to colon and strip off the first word:

```
words = line.split(':')
name = ' '.join(words[1:])
```

We have chosen the former strategy of extracting the name as a substring in the final program.

Each course line is naturally split into words for extracting information:

```
words = line.split()
```

The name of the course consists of a number of words, but we do not know how many. Nevertheless, we know that the final words contain the semester, the credit points, and the grade. We can hence count from the right and extract information, and when we are finished with the semester information, the rest of the `words` list holds the words in the name of the course. The code goes as follows:

```
grade = words[-1]
credit = int(words[-2])
semester = ' '.join(words[-4:-2])
course_name = ' '.join(words[:-4])
data[name].append({'title': course_name,
                  'semester': semester,
                  'credit': credit,
                  'grade': grade})
```

This code is a good example of the usefulness of split and join operations when extracting information from a text.

Now to the second task of computing the average grade. Since the grades are letters we cannot compute with them. A natural way to proceed is to convert the letters to numbers, compute the average number, and then convert that number back to a letter. Conversion between letters and numbers is easily represented by a dictionary:

```
grade2number = {'A': 5, 'B': 4, 'C': 3, 'D': 2, 'E': 1, 'F': 0}
```

To convert from numbers to grades, we construct the “inverse” dictionary:

```
number2grade = {}
for grade in grade2number:
    number2grade[grade2number[grade]] = grade
```

In the computation of the average grade we should use a weighted sum such that larger courses count more than smaller courses. The weighted mean value of a set of numbers r_i with weights w_i , $i = 0, \dots, n - 1$, is

given by

$$\frac{\sum_{i=0}^{n-1} w_i r_i}{\sum_{i=0}^{n-1} w_i}.$$

This weighted mean value must then be rounded to the nearest integer, which can be used as key in `number2grade` to find the corresponding grade expressed as a letter. The weight w_i is naturally taken as the number of credit points in the course with grade r_i . The whole process is performed by the following function:

```
def average_grade(data, name):
    sum = 0; weights = 0
    for course in data[name]:
        weight = course['credit']
        grade = course['grade']
        sum += grade2number[grade]*weight
        weights += weight
    avg = sum/float(weights)
    return number2grade[round(avg)]
```

The complete code is found in the file `students.py`. Running this program gives the following output of the average grades:

```
John Doe: B
Kari Nordmann: C
Jan Modaal: C
```

One feature of the `students.py` code is that the output of the names are sorted after the last name. How can we accomplish that? A straight for `name` in `data` loop will visit the keys in an unknown (random) order. To visit the keys in alphabetic order, we must use

```
for name in sorted(data):
```

This default sort will sort with respect to the first character in the name strings. We want a sort according to the last part of the name. A tailored sort function can then be written (see Exercise 3.32 for an introduction to tailored sort functions). In this function we extract the last word in the names and compare them:

```
def sort_names(name1, name2):
    last_name1 = name1.split()[-1]
    last_name2 = name2.split()[-2]
    if last_name1 < last_name2:
        return -1
    elif last_name1 > last_name2:
        return 1
    else:
        return 0
```

We can now pass on `sort_names` to the `sorted` function to get a sequence that is sorted with respect to the last word in the students' names:

```
for name in sorted(data, sort_names):
    print '%s: %s' % (name, average_grade(data, name))
```

6.8 Exercises

Exercise 6.1. *Read a two-column data file.*

The file `src/files/xy.dat` contains two columns of numbers, corresponding to x and y coordinates on a curve. The start of the file looks as this:

```
-1.0000    -0.0000
-0.9933    -0.0087
-0.9867    -0.0179
-0.9800    -0.0274
-0.9733    -0.0374
```

Make a program that reads the first column into a list `x` and the second column into a list `y`. Then convert the lists to arrays, and plot the curve. Print out the maximum and minimum y coordinates. (Hint: Read the file line by line, split each line into words, convert to `float`, and append to `x` and `y`.) Name of program file: `read_2columns.py` ◇

Exercise 6.2. *Read a data file.*

The files `density_water.dat` and `density_air.dat` files in the folder `src/files` contain data about the density of water and air (resp.) for different temperatures. The data files have some comment lines starting with `#` and some lines are blank. The rest of the lines contain density data: the temperature in the first column and the corresponding density in the second column. The goal of this exercise is to read the data in such a file and plot the density versus the temperature as distinct (small) circles for each data point. Let the program take the name of the data file as command-line argument. Apply the program to both files. Name of program file: `read_density_data.py` ◇

Exercise 6.3. *Simplify the implementation of Exer. 6.1.*

Look up the documentation of the `numpy.loadtxt` function and use it to load the file data in Exercise 6.1 into arrays. Name of program file: `read_2columns_loadtxt.py`. ◇

Exercise 6.4. *Fit a polynomial to data.*

The purpose of this exercise is to find a simple mathematical formula for the how the density of water or air depends on the temperature. First, load the density data from file as explained in Exercises 6.2 or 6.3. Then we want to experiment with NumPy utilities that can find a polynomial that approximate the density curve.

NumPy has a function `polyfit(x, y, deg)` for finding a “best fit” of a polynomial of degree `deg` to a set of data points given by the array arguments `x` and `y`. The `polyfit` function returns a list of the coefficients in the fitted polynomial, where the first element is the coefficient for the term with the highest degree, and the last element corresponds to the constant term. For example, given points in `x` and `y`, `polyfit(x, y,`

1) returns the coefficients a , b in a polynomial $a*x + b$ that fits the data in the best way¹⁷.

NumPy also has a utility `poly1d` which can take the tuple or list of coefficients calculated by, e.g., `polyfit` and return the polynomial as a Python function that can be evaluated. The following code snippet demonstrates the use of `polyfit` and `poly1d`:

```
coeff = polyfit(x, y, deg)
p = poly1d(coeff)
print p # prints the polynomial expression
y_fitted = p(x)
plot(x, y, 'r-', x, y_fitted, 'b-',
      legend=('data', 'fitted polynomial of degree %d' % deg'))
```

For the density–temperature relationship we want to plot the data from file and two polynomial approximations, corresponding to a 1st and 2nd degree polynomial. From a visual inspection of the plot, suggest simple mathematical formulas that relate the density of air to temperature and the density of water to temperature. Make three separate plots of the Name of program file: `fit_density_data.py` ◇

Exercise 6.5. *Read acceleration data and find velocities.*

A file `src/files/acc.dat` contains measurements a_0, a_1, \dots, a_{n-1} of the acceleration of an object moving along a straight line. The measurement a_k is taken at time point $t_k = k\Delta t$, where Δt is the time spacing between the measurements. The purpose of the exercise is to load the acceleration data into a program and compute the velocity $v(t)$ of the object at some time t .

In general, the acceleration $a(t)$ is related to the velocity $v(t)$ through $v'(t) = a(t)$. This means that

$$v(t) = v(0) + \int_0^t a(\tau) d\tau. \quad (6.1)$$

If $a(t)$ is only known at some discrete, equally spaced points in time, a_0, \dots, a_{n-1} (which is the case in this exercise), we must compute the integral (6.1) numerically, for example by the Trapezoidal rule:

$$v(t_k) \approx \Delta t \left(\frac{1}{2} a_0 + \frac{1}{2} a_k + \sum_{i=1}^{k-1} a_i \right), \quad 1 \leq k \leq n-1. \quad (6.2)$$

We assume $v(0) = 0$ so that also $v_0 = 0$.

Read the values a_0, \dots, a_{n-1} from file into an array, plot the acceleration versus time, and use (6.2) to compute one $v(t_k)$ value, where Δt

¹⁷ More precisely, a line $y = ax + b$ is a “best fit” to the data points (x_i, y_i) , $i = 0, \dots, n-1$ if a and b are chosen to make the sum of squared errors $R = \sum_{j=0}^{n-1} (y_j - (ax_j + b))^2$ as small as possible. This approach is known as *least squares approximation* to data and proves to be extremely useful throughout science and technology.

and $k \geq 1$ are specified on the command line. Name of program file: `acc2vel_v1.py`. \diamond

Exercise 6.6. *Read acceleration data and plot velocities.*

The task in this exercise is the same as in Exercise 6.5, except that we now want to compute $v(t_k)$ for all time points $t_k = k\Delta t$ and plot the velocity versus time. Repeated use of (6.2) for all k values is very inefficient. A more efficient formula arises if we add the area of a new trapezoid to the previous integral (see also Appendix A.1.7):

$$v(t_k) = v(t_{k-1}) + \int_{t_{k-1}}^{t_k} a(\tau) d\tau \approx v(t_{k-1}) + \Delta t \frac{1}{2}(a_{k-1} + a_k), \quad (6.3)$$

for $k = 1, 2, \dots, n-1$, while $v_0 = 0$. Use this formula to fill an array `v` with velocity values. Now only Δt is given on the command line, and the a_0, \dots, a_{n-1} values must be read from file as in Exercise 6.5. Name of program file: `acc2vel.py`. \diamond

Exercise 6.7. *Find velocity from GPS coordinates.*

Imagine that a GPS device measures your position at every s seconds. The positions are stored as (x, y) coordinates in a file `src/files/pos.dat` with the an x and y number on each line, except for the first line which contains the value of s .

First, load s into a `float` variable and the x and y numbers into two arrays and draw a straight line between the points (i.e., plot the y coordinates versus the x coordinates).

The next task is to compute and plot the velocity of the movements. If $x(t)$ and $y(t)$ are the coordinates of the positions as a function of time, we have that the velocity in x direction is $v_x(t) = dx/dt$, and the velocity in y direction is $v_y = dy/dt$. Since x and y are only known for some discrete times, $t_k = ks$, $k = 0, \dots, n-1$, we must use numerical differentiation. A simple (forward) formula is

$$v_x(t_k) \approx \frac{x(t_{k+1}) - x(t_k)}{s}, \quad v_y(t_k) \approx \frac{y(t_{k+1}) - y(t_k)}{s},$$

$$k = 0, \dots, n-2.$$

Compute arrays `vx` and `vy` with velocities based on the formulas above for $v_x(t_k)$ and $v_y(t_k)$, $k = 0, \dots, n-2$. Plot `vx` versus time and `vy` versus time. Name of program file: `position2velocity.py`. \diamond

Exercise 6.8. *Make a dictionary from a table.*

The file `src/files/constants.txt` contains a table of the values and the dimensions of some fundamental constants from physics. We want to load this table into a dictionary `constants`, where the keys are the names of the constants. For example, `constants['gravitational constant']` holds the value of the gravitational constant ($6.67259 \cdot 10^{-11}$) in Newton's law of gravitation. Make a function that reads and

interprets the text in the file, and thereafter returns the dictionary.
Name of program file: `fundamental_constants.py`. ◇

Exercise 6.9. *Explore syntax differences: lists vs. dictionaries.*

Consider this code:

```
t1 = {}
t1[0] = -5
t1[1] = 10.5
```

Explain why the lines above work fine while the ones below do not:

```
t2 = []
t2[0] = -5
t2[1] = 10.5
```

What must be done in the last code snippet to make it work properly?
Name of program file: `list_vs_dict.py`. ◇

Exercise 6.10. *Improve the program from Ch. 6.2.5.*

Consider the program `density.py` from Chapter 6.2.5. One problem we face when implementing this program is that the name of the substance can contain one or two words, and maybe more words in a more comprehensive table. The purpose of this exercise is to use string operations to shorten the code and make it more general. Implement the following two methods in separate functions in the same program, and control that they give the same result.

1. Let `substance` consist of all the words but the last, using the `join` method in string objects to combine the words.
2. Observe that all the densities start in the same column file and use substrings to divide `line` into two parts. (Hint: Remember to strip the first part such that, e.g., the density of ice is obtained as `densities['ice']` and not `densities['ice ']`.)

Name of program file: `density_improved.py`. ◇

Exercise 6.11. *Interpret output from a program.*

The program `src/funcif/lsum.py` produces, among other things, this output:

```
epsilon: 1e-04, exact error: 8.18e-04, n=55
epsilon: 1e-06, exact error: 9.02e-06, n=97
epsilon: 1e-08, exact error: 8.70e-08, n=142
epsilon: 1e-10, exact error: 9.20e-10, n=187
epsilon: 1e-12, exact error: 9.31e-12, n=233
```

Redirect the output to a file (by `python lsum.py > file`). Write a Python program that reads the file and extracts the numbers corresponding to `epsilon`, `exact error`, and `n`. Store the numbers in three arrays and plot `epsilon` and the `exact error` versus `n`. Use a logarithmic scale on the y axis (enabled by the `log='y'` keyword argument to the `plot` function). Name of program file: `read_error.py`. ◇

Exercise 6.12. *Make a dictionary.*

Based on the stars data in Exercise 3.32, make a dictionary where the keys contain the names of the stars and the values correspond to the luminosity. Name of program file: `stars_data_dict1.py`. ◇

Exercise 6.13. *Make a nested dictionary.*

Store the data about stars from Exercise 3.32 in a nested dictionary such that we can look up the distance, the apparent brightness, and the luminosity of a star with name `N` by

```
stars[N]['distance']
stars[N]['apparent brightness']
stars[N]['luminosity']
```

Name of program file: `stars_data_dict2.py`. ◇

Exercise 6.14. *Make a nested dictionary from a file.*

The file `src/files/human_evolution.txt` holds information about various human species and their height, weight, and brain volume. Make a program that reads this file and stores the tabular data in a nested dictionary `humans`. The keys in `humans` correspond to the specie name (e.g., “homo erectus”), and the values are dictionaries with keys for “height”, “weight”, “brain volume”, and “when” (the latter for when the specie lived). For example, `humans['homo neanderthalensis']['mass']` should equal `'55-70'`. Let the program write out the `humans` dictionary in a nice tabular form similar to that in the file. Name of program file: `humans.py`. ◇

Exercise 6.15. *Compute the area of a triangle.*

The purpose of this exercise is to write an `area` function as in Exercise 3.9, but now we assume that the vertices of the triangle is stored in a dictionary and not a list. The keys in the dictionary correspond to the vertex number (1, 2, or 3) while the values are 2-tuples with the x and y coordinates of the vertex. For example, in a triangle with vertices $(0, 0)$, $(1, 0)$, and $(0, 2)$ the `vertices` argument becomes

```
{1: (0,0), 2: (1,0), 3: (0,2)}
```

Name of program file: `area_triangle_dict.py`. ◇

Exercise 6.16. *Compare data structures for polynomials.*

Write a code snippet that uses both a list and a dictionary to represent the polynomial $-\frac{1}{2} + 2x^{100}$. Print the list and the dictionary, and use them to evaluate the polynomial for $x = 1.05$ (you can apply the `poly1` and `poly2` functions from Chapter 6.2.3). Name of program file: `poly_repr.py`. ◇

Exercise 6.17. *Compute the derivative of a polynomial.*

A polynomial can be represented by a dictionary as explained in Chapter 6.2.3. Write a function `diff` for differentiating such a polynomial. The `diff` function takes the polynomial as a dictionary argument

and returns the dictionary representation of the derivative. Recall the formula for differentiation of polynomials:

$$\frac{d}{dx} \sum_{j=0}^n c_j x^j = \sum_{j=1}^n j c_j x^{j-1}. \quad (6.4)$$

This means that the coefficient of the x^{j-1} term in the derivative equals j times the coefficient of x^j term of the original polynomial. With p as the polynomial dictionary and dp as the dictionary representing the derivative, we then have $dp[j-1] = j*p[j]$ for j running over all keys in p , except when j equals 0.

Here is an example of the use of the function `diff`:

```
>>> p = {0: -3, 3: 2, 5: -1}      # -3 + 2*x**3 - x**5
>>> diff(p)                       # should be 6*x**2 - 5*x**4
{2: 6, 4: -5}
```

Name of program file: `poly_diff.py`. ◇

Exercise 6.18. *Generalize the program from Ch. 6.2.7.*

The program from Chapter 6.2.7 is specialized for three particular companies. Suppose you download n files from *finance.yahoo.com*, all with monthly stock price data for the *same* period of time. Also suppose you name these files `company.csv`, where `company` reflects the name of the company. Modify the program from Chapter 6.2.7 such that it reads a set of filenames from the command line and creates a plot that compares the evolution of the corresponding stock prices. Normalize all prices such that they initially start at a unit value. Name of program file: `stockprices3.py`. ◇

Exercise 6.19. *Write function data to file.*

We want to dump x and $f(x)$ values to a file, where the x values appear in the first column and the $f(x)$ values appear in the second. Choose n equally spaced x values in the interval $[a, b]$. Provide f , a , b , n , and the filename as input data on the command line. Use the `StringFunction` tool (see Chapters 4.1.4 and 5.5.1) to turn the textual expression for f into a Python function. (Note that the program from Exercise 6.1 can be used to read the file generated in the present exercise into arrays again for visualization of the curve $y = f(x)$.) Name of program files `write_cml_function.py`. ◇

Exercise 6.20. *Specify functions on the command line.*

Explain what the following two code snippets do and give an example of how they can be used. Snippet 1:

```
import sys
from scitools.StringFunction import StringFunction
parameters = {}
for prm in sys.argv[4:]:
```



```

    key, value = prm.split('=')
    parameters[key] = eval(value)
f = StringFunction(sys.argv[1], independent_variables=sys.argv[2],
                  **parameters)
var = float(sys.argv[3])
print f(var)

```

Snippet 2:

```

import sys
from scitools.StringFunction import StringFunction
f = eval('StringFunction(sys.argv[1], ' + \
        'independent_variables=sys.argv[2], %s)' % \
        ('', '.join(sys.argv[4:]))')
var = float(sys.argv[3])
print f(var)

```

Hint: Read about the `StringFunction` tool in Chapter 4.1.4 and about a variable number of keyword arguments in Appendix H.5. Name of program file: `cml_functions.py`. \diamond

Exercise 6.21. *Interpret function specifications.*

To specify arbitrary functions $f(x_1, x_2, \dots; p_1, p_2, \dots)$ with independent variables x_1, x_2, \dots and a set of parameters p_1, p_2, \dots , we allow the following syntax on the command line or in a file:

`<expression>` is function of `<list1>` with parameter `<list2>`

where `<expression>` denotes the function formula, `<list1>` is a comma-separated list of the independent variables, and `<list2>` is a comma-separated list of name = value parameters. The part with parameters `<list2>` is omitted if there are no parameters. The names of the independent variables and the parameters can be chosen freely as long as the names can be used as Python variables. Here are four different examples of what we can specify on the command line using this syntax:

```

sin(x) is a function of x
sin(a*y) is a function of y with parameter a=2
sin(a*x-phi) is a function of x with parameter a=3, phi=-pi
exp(-a*x)*cos(w*t) is a function of t with parameter a=1,w=pi,x=2

```

Create a Python function that takes such function specifications as input and returns an appropriate `StringFunction` object. This object must be created from the function expression and the list of independent variables and parameters. For example, the last function specification above leads to the following `StringFunction` creation:

```

f = StringFunction('exp(-a*x)*sin(k*x-w*t)',
                  independent_variables=['t'],
                  a=1, w=pi, x=2)

```

Hint: Use string operations to extract the various parts of the string. For example, the expression can be split out by calling `split('is a function')`. Typically, you need to extract `<expression>`, `<list1>`, and `<list2>`, and create a string like

```
StringFunction(<expression>, independent_variables=[<list1>],
              <list2>)
```

and sending it to `eval` to create the object. Name of program file: `text2func.py`. ◇

Exercise 6.22. *Compare average temperatures in cities.*

The tarfile `src/misc/city_temp.tar.gz` contains a set of files with temperature data for a large number of cities around the world. The files are in text format with four columns, containing the month number, the date, the year, and the temperature, respectively. Missing temperature observations are represented by the value `-99`. The mapping between the names of the text files and the names of the cities are defined in an HTML file `citylistWorld.htm`.

First, write a function that can read the `citylistWorld.htm` file and create a dictionary with mapping between city and filenames. Second, write a function that takes this dictionary and a city name as input, opens the corresponding text file, and loads the data into an appropriate data structure (dictionary of arrays and city name is a suggestion). Third, write a function that can take a number of such data structures and the corresponding city names to create a plot of the temperatures over a certain time period.

Name of program file: `temperature_data.py`. ◇

Exercise 6.23. *Try Word or OpenOffice to write a program.*

The purpose of this exercise is to tell you how hard it may be to write Python programs in the standard programs that most people use for writing text.

Type the following one-line program in either Microsoft Word or OpenOffice:

```
print "Hello, World!"
```

Both Word and OpenOffice are so “smart” that they automatically edit “print” to “Print” since a sentence should always start with a capital. This is just an example that word processors are made for writing documents, not computer programs.

Save the program as a `.doc` (Word) or `.odt` (OpenOffice) file. Now try to run this file as a Python program. You will get a message

```
SyntaxError: Non-ASCII character
```

Explain why you get this error.

Then save the program as a `.txt` file. Run this file as a Python program. It may work well if you wrote the program text in Microsoft Word, but with OpenOffice there may still be strange characters in the file. Use a text editor to view the exact contents of the file. Name of program file: `office.py`. ◇

Exercise 6.24. *Evaluate objects in a boolean context.*

Writing `if a:` or `while a:` in a program, where `a` is some object, requires evaluation of `a` in a boolean context. To see the value of an object `a` in a boolean context, one can call `bool(a)`. Try the following program to learn what values of what objects that are `True` or `False` in a boolean context:

```
objects = [
    '',          # empty string
    'string',   # non-empty string
    [],         # empty list
    [0],        # list with one element
    (),         # empty tuple
    (0,),       # tuple with one element
    {},         # empty dict
    {0:0},      # dict with one element
    0,          # int zero
    0.0,        # float zero
    0j,         # complex zero
    10,         # int 10
    10.,        # float 10
    10j,        # imaginary 10
    zeros(0),   # empty array
    zeros(1),   # array with one element (zero)
    zeros(1)+10, # array with one element (10)
    zeros(2),   # array with two elements (watch out!)
]
for element in objects:
    object = eval(element)
    print 'object = %s; if object: is %s' % \
        (element, bool(object))
```

Write down a rule for the family of Python objects that evaluate to `False` in a boolean context. ◇

Exercise 6.25. *Fit a polynomial to experimental data.*

Suppose we have measured the oscillation period T of a simple pendulum with a mass m at the end of a massless rod of length L . We have varied L and recorded the corresponding T value. The measurements are found in a file `src/files/pendulum.dat`, containing two columns. The first column contains L values and the second column has the corresponding T values.

Load the L and T values into two arrays. Plot L versus T using circles for the data points. We shall assume that L as a function of T is a polynomial. Use the NumPy utilities `polyfit` and `poly1d`, as explained in Exercise 6.4, and experiment with fitting polynomials of degree 1, 2, and 3. Visualize the polynomial curves together with the experimental data. Which polynomial fits the measured data best? Name of program file: `fit_pendulum_data.py`. ◇

Exercise 6.26. *Generate an HTML report with figures.*

The goal of this exercise is to let a program write a report in HTML format containing the solution to Exercise 5.22 on page 249. First,

include the program from that Exercises, with additional explaining text if necessary. Program code can be placed inside `<pre>` and `</pre>` tags. Second, insert three plots of the $f(x, t)$ function for three different t values (find suitable t values that illustrate the displacement of the wave packet). Third, add an animated GIF file with the movie of $f(x, t)$. Insert headlines (`<h1>` tags) wherever appropriate. Name of program file: `wavepacket_report.py`. ◇

Exercise 6.27. *Extract information from a weather page.*

Find the Yahoo! page with the weather forecast for your favorite city. Study the HTML source and write a program that downloads the HTML page, extracts forecast information such as weather type, temperature, etc. Write out this information in a compact style on the screen. This exercise is a starter for the more useful Exercise 6.28 for comparing alternative forecasts in a compact fashion. Name of program file: `Yahoo_weather.py`. ◇

Exercise 6.28. *Compare alternative weather forecasts.*

For each of a collection of weather forecast sites, say

```
http://weather.yahoo.com
http://www.weather.com
http://www.weatherchannel.com
http://weather.cnn.com
http://yr.no
```

find the pages corresponding to your favorite location. Study the HTML sources and write a function for each HTML page that downloads the web page and extracts basic forecast information: date, weather type (name of symbol), and temperature. Write out a comparison of different forecasts on the screen. Name of program file: `weather_forecast_comparison1.py`. ◇

Exercise 6.29. *Improve the output in Exercise 6.28.*

Pure text on the screen was suggested as output in Exercise 6.28. A useful alternative is to construct an HTML page with compact forecast information, where also weather symbols (images) are displayed. Extend each of the functions in Exercise 6.28 to also extract the filename containing the weather symbol(s) and write the code for presenting the comparison in HTML. Name of program file: `weather_forecast_comparison2.py`. ◇

Exercise 6.30. *Allow different types for a function argument.*

Consider the family of `find_consensus_v*` functions from Chapter 6.6.2. The different versions work on different representations of the frequency matrix. Make a unified `find_consensus` function which accepts different data structures for the `frequency_matrix`. Test on the type of data structure and perform the necessary actions. Name of program file: `find_consensus.py`. ◇

Exercise 6.31. *Make a function more robust.*

Consider the function `get_base_counts(dna)` (from Chapter 6.6.3), which counts how many times A, C, G, and T appears in the string `dna`:

Unfortunately, this function crashes if other letters appear in `dna`. Write an enhanced function `get_base_counts2` which solves this problem. Test it on a string like `'ADLSTLLD'`. Name of program file: `get_base_counts2.py`. ◇

```
def get_base_counts(dna):
    counts = {'A': 0, 'T': 0, 'G': 0, 'C': 0}
    for base in dna:
        counts[base] += 1
    return counts
```

Exercise 6.32. *Find proportion of bases inside/outside exons.*

Consider the lactase gene as described in Chapters 6.6.4 and 6.6.5. What is the proportion of base A inside and outside exons of the lactase gene? Write a function `get_exons`, which returns all the substrings of the exon regions concatenated, and a function `get_introns`, which returns all the substrings between the exon regions concatenated. The function `get_base_frequencies` from Chapter 6.6.3 can then be used to analyze the frequencies of bases A, C, G, and T in the two strings. Name of program file: `prop_A_exons.py`. ◇

A class packs a set of data (variables) together with a set of functions operating on the data. The goal is to achieve more modular code by grouping data and functions into manageable (often small) units. Most of the mathematical computations in this book can easily be coded without using classes, but in many problems, classes enable either more elegant solutions or code that is easier to extend at a later stage. In the non-mathematical world, where there are no mathematical concepts and associated algorithms to help structure the problem solving, software development can be very challenging. Classes may then improve the understanding of the problem and contribute to simplify the modeling of data and actions in programs. As a consequence, almost all large software systems being developed in the world today are heavily based on classes.

Programming with classes is offered by most modern programming languages, also Python. In fact, Python employs classes to a very large extent, but one can – as we have seen in previous chapters – use the language for lots of purposes without knowing what a class is. However, one will frequently encounter the class concept when searching books or the World Wide Web for Python programming information. And more important, classes often provide better solutions to programming problems. This chapter therefore gives an introduction to the class concept with emphasis on applications to numerical computing. More advanced use of classes, including inheritance and object orientation, is the subject of Chapter 9.

The folder `src/class` contains all the program examples from the present chapter.

7.1 Simple Function Classes

Classes can be used for many things in scientific computations, but one of the most frequent programming tasks is to represent mathematical functions which have a set of parameters in addition to one or more independent variables. Chapter 7.1.1 explains why such mathematical functions pose difficulties for programmers, and Chapter 7.1.2 shows how the class idea meets these difficulties. Chapter 7.1.3 presents another example where a class represents a mathematical function. More advanced material about classes, which for some readers may clarify the ideas, but which can also be skipped in a first reading, appears in Chapters 7.1.4 and Chapter 7.1.5.

7.1.1 Problem: Functions with Parameters

To motivate for the class concept, we will look at functions with parameters. The $y(t) = v_0t - \frac{1}{2}gt^2$ function on page 1 is such a function. Conceptually, in physics, y is a function of t , but y also depends on two other parameters, v_0 and g , although it is not natural to view y as a function of these parameters. We may write $y(t; v_0, g)$ to indicate that t is the independent variable, while v_0 and g are parameters. Strictly speaking, g is a fixed parameter¹, so only v_0 and t can be arbitrarily chosen in the formula. It would then be better to write $y(t; v_0)$.

In the general case, we may have a function of x that has n parameters p_1, \dots, p_n : $f(x; p_1, \dots, p_n)$. One example could be

$$g(x; A, a) = Ae^{-ax}.$$

How should we implement such functions? One obvious way is to have the independent variable and the parameters as arguments:

```
def y(t, v0):
    g = 9.81
    return v0*t - 0.5*g*t**2

def g(x, a, A):
    return A*exp(-a*x)
```

Problem. There is one major problem with this solution. Many software tools we can use for mathematical operations on functions assume that a function of one variable has only one argument in the computer representation of the function. For example, we may have a tool for differentiating a function $f(x)$ at a point x , using the approximation

$$f'(x) \approx \frac{f(x+h) - f(x)}{h} \quad (7.1)$$

¹ As long as we are on the surface of the earth, g can be considered fixed, but in general g depends on the distance to the center of the earth.

coded as

```
def diff(f, x, h=1E-5):
    return (f(x+h) - f(x))/h
```

The `diff` function works with any function `f` that takes one argument:

```
def h(t):
    return t**4 + 4*t

dh = diff(h, 0.1)

from math import sin, pi
x = 2*pi
dsin = diff(sin, x, h=1E-6)
```

Unfortunately, `diff` will not work with our `y(t, v0)` function. Calling `diff(y, t)` leads to an error inside the `diff` function, because it tries to call our `y` function with only one argument while the `y` function requires two.

Writing an alternative `diff` function for `f` functions having two arguments is a bad remedy as it restricts the set of admissible `f` functions to the very special case of a function with one independent variable and one parameter. A fundamental principle in computer programming is to strive for software that is as general and widely applicable as possible. In the present case, it means that the `diff` function should be applicable to all functions `f` of one variable, and letting `f` take one argument is then the natural decision to make.

The mismatch of function arguments, as outlined above, is a major problem because a lot of software libraries are available for operations on mathematical functions of one variable: integration, differentiation, solving $f(x) = 0$, finding extrema, etc. (see for instance Chapter 4.6.2 and Appendices A.1.10, B, C, and E). All these libraries will try to call the mathematical function we provide with only one argument.

A Bad Solution: Global Variables. The requirement is thus to define Python implementations of mathematical functions of one variable with one argument, the independent variable. The two examples above must then be implemented as

```
def y(t):
    g = 9.81
    return v0*t - 0.5*g*t**2

def g(t):
    return A*exp(-a*x)
```

These functions work only if `v0`, `A`, and `a` are global variables, initialized before one attempts to call the functions. Here are two sample calls where `diff` differentiates `y` and `g`:

```
v0 = 3
dy = diff(y, 1)

A = 1; a = 0.1
dg = diff(g, 1.5)
```

The use of global variables is in general considered bad programming. Why global variables are problematic in the present case can be illustrated when there is need to work with several versions of a function. Suppose we want to work with two versions of $y(t; v_0)$, one with $v_0 = 1$ and one with $v_0 = 5$. Every time we call `y` we must remember which version of the function we work with, and set `v0` accordingly prior to the call:

```
v0 = 1; r1 = y(t)
v0 = 5; r2 = y(t)
```

Another problem is that variables with simple names like `v0`, `a`, and `A` may easily be used as global variables in other parts of the program. These parts may change our `v0` in a context different from the `y` function, but the change affects the correctness of the `y` function. In such a case, we say that changing `v0` has *side effects*, i.e., the change affects other parts of the program in an unintentional way. This is one reason why a golden rule of programming tells us to limit the use of global variables as much as possible.

Another solution to the problem of needing two v_0 parameters could be to introduce two `y` functions, each with a distinct v_0 parameter:

```
def y1(t):
    g = 9.81
    return v0_1*t - 0.5*g*t**2

def y2(t):
    g = 9.81
    return v0_2*t - 0.5*g*t**2
```

Now we need to initialize `v0_1` and `v0_2` once, and then we can work with `y1` and `y2`. However, if we need 100 v_0 parameters, we need 100 functions. This is tedious to code, error prone, difficult to administer, and simply a really bad solution to a programming problem.

So, is there a good remedy? The answer is yes: The class concept solves all the problems described above!

7.1.2 Representing a Function as a Class

A class contains a set of variables (data) and a set of functions, held together as one unit. The variables are visible in all the functions in the class. That is, we can view the variables as “global” in these functions. These characteristics also apply to modules, and modules can be used to obtain many of the same advantages as classes offer (see comments

in Chapter 7.1.5). However, classes are technically very different from modules. You can also make many copies of a class, while there can be only one copy of a module. When you master both modules and classes, you will clearly see the similarities and differences. Now we continue with a specific example of a class.

Consider the function $y(t; v_0) = v_0 t - \frac{1}{2} g t^2$. We may say that v_0 and g , represented by the variables `v0` and `g`, constitute the data. A Python function, say `value(t)`, is needed to compute the value of $y(t; v_0)$ and this function must have access to the data `v0` and `g`, while `t` is an argument.

A programmer experienced with classes will then suggest to collect the data `v0` and `g`, and the function `value(t)`, together as a class. In addition, a class usually has another function, called *constructor* for initializing the data. The constructor is always named `__init__`. Every class must have a name, often starting with a capital, so we choose `Y` as the name since the class represents a mathematical function with name y . Figure 7.1 sketches the contents of class `Y` as a so-called UML diagram, here created with Lumpy (from Appendix H.3) with aid of the little program `class_Y_v1_UML.py`. The UML diagram has two “boxes”, one where the functions are listed, and one where the variables are listed. Our next step is to implement this class in Python.

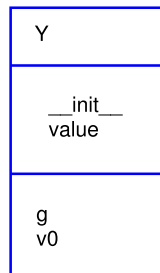

Fig. 7.1 UML diagram with function and data in the simple class `Y` for representing a mathematical function $y(t; v_0)$.

Implementation. The complete code for our class `Y` looks as follows in Python:

```

class Y:
    def __init__(self, v0):
        self.v0 = v0
        self.g = 9.81

    def value(self, t):
        return self.v0*t - 0.5*self.g*t**2
  
```

A puzzlement for newcomers to Python classes is the `self` parameter, which may take some efforts and time to fully understand.

Usage and Dissection. Before we dig into what each in the class implementation means, we start by showing how the class can be used to compute values of the mathematical function $y(t; v_0)$.

A class creates a new data type, here of name `Y`, so when we use the class to make objects, those objects are of type `Y`². An object of a user-defined class (like `Y`) is usually called an *instance*. We need such an instance in order to use the data in the class and call the `value` function. The following statement constructs an instance bound to the variable name `y`:

```
y = Y(3)
```

Seemingly, we call the class `Y` as if it were a function. Actually, `Y(3)` is automatically translated by Python to a call to the constructor `__init__` in class `Y`. The arguments in the call, here only the number 3, are always passed on as arguments to `__init__` after the `self` argument. That is, `v0` gets the value 3 and `self` is just dropped in the call. This may be confusing, but it is a rule that the `self` argument is never used in calls to functions in classes.

With the instance `y`, we can compute the value $y(t = 0.1; v_0 = 3)$ by the statement

```
v = y.value(0.1)
```

Here also, the `self` argument is dropped in the call to `value`. To access functions and variables in a class, we must prefix the function and variable names by the name of the instance and a dot: the `value` function is reached as `y.value`, and the variables are reached as `y.v0` and `y.g`. We can, for example, print the value of `v0` in the instance `y` by writing

```
print y.v0
```

The output will in this case be 3.

We have already introduced the term “instance” for the object of a class. Functions in classes are commonly called *methods*, and variables (data) in classes are called *attributes*. From now on we will use this terminology. In our sample class `Y` we have two methods, `__init__` and `value`, and two attributes, `v0` and `g`. The names of methods and attributes can be chosen freely, just as names of ordinary Python functions and variables. However, the constructor must have the name `__init__`, otherwise it is not automatically called when we create new instances.

You can do whatever you want in whatever method, but it is a convention to use the constructor for initializing the variables in the class such that the class is “ready for use”.

² All familiar Python objects, like lists, tuples, strings, floating-point numbers, integers, etc., are in fact built-in Python classes, with names `list`, `tuple`, `str`, `float`, `int`, etc.

The self Variable. Now we will provide some more explanation of the `self` parameter and how the class methods work. Inside the constructor `__init__`, the argument `self` is a variable holding the new instance to be constructed. When we write

```
self.v0 = v0
self.g = 9.81
```

we define two new attributes in this instance. The `self` parameter is invisibly returned to the calling code. We can imagine that Python translates `y = Y(3)` to

```
Y.__init__(y, 3)
```

so when we do a `self.v0 = v0` in the constructor, we actually initialize `y.v0`. The prefix with `Y.` is necessary to reach a class method (just like prefixing a function in a module with the module name, e.g., `math.exp`). If we prefix with `Y.`, we need to explicitly feed in an instance for the `self` argument, like `y` in the code line above, but if we prefix with `y.` (the instance name) the `self` argument is dropped. It is the latter “instance name prefix” which we shall use when computing with classes.

Let us look at a call to the `value` method to see a similar use of the `self` argument. When we write

```
value = y.value(0.1)
```

Python translates this to a call

```
value = Y.value(y, 0.1)
```

such that the `self` argument in the `value` method becomes the `y` instance. In the expression inside the `value` method,

```
self.v0*t - 0.5*self.g*t**2
```

`self` is `y` so this is the same as

```
y.v0*t - 0.5*y.g*t**2
```

The rules regarding “`self`” are listed below:

- Any class method must have `self` as first argument³.
- `self` represents an (arbitrary) instance of the class.
- To access another class method or a class attribute, inside class methods, we must prefix with `self`, as in `self.name`, where `name` is the name of the attribute or the other method.
- `self` is dropped as argument in calls to class methods.

³ The name can be any valid variable name, but the name `self` is a widely established convention in Python.

It takes some time to understand the `self` variable, but more examples and hands-on experience with class programming will help, so just be patient and continue reading.

Extension of the Class. We can have as many attributes and methods as we like in a class, so let us add a new method to class `Y`. This method is called `formula` and prints a string containing the formula of the mathematical function y . After this formula, we provide the value of v_0 . The string can then be constructed as

```
'v0*t - 0.5*g*t**2; v0=%g' % self.v0
```

where `self` is an instance of class `Y`. A call of `formula` does not need any arguments:

```
print y.formula()
```

should be enough to create, return, and print the string. However, even if the `formula` method does not need any arguments, it must have a `self` argument, which is left out in the call but needed inside the method to access the attributes. The implementation of the method is therefore

```
def formula(self):
    return 'v0*t - 0.5*g*t**2; v0=%g' % self.v0
```

For completeness, the whole class now reads

```
class Y:
    def __init__(self, v0):
        self.v0 = v0
        self.g = 9.81

    def value(self, t):
        return self.v0*t - 0.5*self.g*t**2

    def formula(self):
        return 'v0*t - 0.5*g*t**2; v0=%g' % self.v0
```

Example on use may be

```
y = Y(5)
t = 0.2
v = y.value(t)
print 'y(t=%g; v0=%g) = %g' % (t, y.v0, v)
print y.formula()
```

with the output

```
y(t=0.2; v0=5) = 0.8038
v0*t - 0.5*g*t**2; v0=5
```

Remark. A common mistake done by newcomers to the class construction is to place the code that applies the class at the same indentation as the class methods. This is illegal. Only method definitions and assignments to so-called static attributes (Chapter 7.6) can appear in

the indented block under the `class` headline. Ordinary attribute assignment must be done inside methods. The main program using the class must appear with the same indent as the `class` headline.

Using Methods as Ordinary Functions. We may create several y functions with different values of v_0 :

```
y1 = Y(1)
y2 = Y(1.5)
y3 = Y(-3)
```

We can treat `y1.value`, `y2.value`, and `y3.value` as ordinary Python functions of t , and then pass them on to any Python function that expects a function of one variable. In particular, we can send the functions to the `diff(f, x)` function from page 343:

```
dy1dt = diff(y1.value, 0.1)
dy2dt = diff(y2.value, 0.1)
dy3dt = diff(y3.value, 0.2)
```

Inside the `diff(f, x)` function, the argument `f` now behaves as a function of one variable that automatically carries with it two variables v_0 and g . When `f` refers to (e.g.) `y3.value`, Python actually knows that `f(x)` means `y3.value(x)`, and inside the `y3.value` method `self` is `y3`, and we have access to `y3.v0` and `y3.g`.

Doc Strings. A function may have a doc string right after the function definition, see Chapter 3.1.7. The aim of the doc string is to explain the purpose of the function and, for instance, what the arguments and return values are. A class can also have a doc string, it is just the first string that appears right after the `class` headline. The convention is to enclose the doc string in triple double quotes `"""`:

```
class Y:
    """The vertical motion of a ball."""

    def __init__(self, v0):
        ...
```

More comprehensive information can include the methods and how the class is used in an interactive session:

```
class Y:
    """
    Mathematical function for the vertical motion of a ball.

    Methods:
        constructor(v0): set initial velocity v0.
        value(t): compute the height as function of t.
        formula(): print out the formula for the height.

    Attributes:
        v0: the initial velocity of the ball (time 0).
        g: acceleration of gravity (fixed).
```

```

Usage:
>>> y = Y(3)
>>> position1 = y.value(0.1)
>>> position2 = y.value(0.3)
>>> print y.formula()
v0*t - 0.5*g*t**2; v0=3
"""

```

7.1.3 Another Function Class Example

Let us apply the ideas from the `Y` class to the $v(r)$ function specified in (5.23) on page 252. We may write this function as $v(r; \beta, \mu_0, n, R)$ to indicate that there is one primary independent variable (r) and four physical parameters (β , μ_0 , n , and R). The class typically holds the physical parameters as variables and provides an `value(r)` method for computing the v function:

```

class VelocityProfile:
    def __init__(self, beta, mu0, n, R):
        self.beta, self.mu0, self.n, self.R = beta, mu0, n, R

    def value(self, r):
        beta, mu0, n, R = self.beta, self.mu0, self.n, self.R
        n = float(n) # ensure float divisions
        v = (beta/(2.0*mu0))**(1/n)*(n/(n+1))*\
            (R**(1+1/n) - r**(1+1/n))
        return v

```

There is seemingly one new thing here in that we initialize several variables on the same line⁴:

```
self.beta, self.mu0, self.n, self.R = beta, mu0, n, R
```

This is perfectly valid Python code and equivalent to the multi-line code

```
self.beta = beta
self.mu0 = mu0
self.n = n
self.R = R
```

In the `value` method it is convenient to avoid the `self.` prefix in the mathematical formulas and instead introduce the local short names `beta`, `mu0`, `n`, and `R`. This is in general a good idea, because it makes it easier to read the implementation of the formula and check its correctness.

Here is one possible application of class `VelocityProfile`:

⁴ The comma-separated list of variables on the right-hand side forms a tuple so this assignment is just the usual construction where a set of variables on the left-hand side is set equal to a list or tuple on the right-hand side, element by element. See page 57.

```
v1 = VelocityProfile(R=1, beta=0.06, mu0=0.02, n=0.1)
# Plot v1 versus r
from scitools.std import *
r = linspace(0, 1, 50)
v = v1.value(r)
plot(r, v, label=('r', 'v'), title='Velocity profile')
```

Remark. Another solution to the problem of sending functions with parameters to a general library function such as `diff` is provided in Appendix H.5. The remedy there is to transfer the parameters as arguments “through” the `diff` function. This can be done in a general way as explained in that appendix.

7.1.4 Alternative Function Class Implementations

To illustrate class programming further, we will now realize class `Y` from Chapter 7.1.2 in a different way. You may consider this section as advanced and skip it, but for some readers the material might improve the understanding of class `Y` and give some insight into class programming in general.

It is a good habit always to have a constructor in a class and to initialize class attributes here, but this is not a requirement. Let us drop the constructor and make `v0` an optional argument to the `value` method. If the user does not provide `v0` in the call to `value`, we use a `v0` value that must have been provided in an earlier call and stored as an attribute `self.v0`. We can recognize if the user provides `v0` as argument or not by using `None` as default value for the keyword argument and then test if `v0` is `None`.

Our alternative implementation of class `Y`, named `Y2`, now reads

```
class Y2:
    def value(self, t, v0=None):
        if v0 is not None:
            self.v0 = v0
        g = 9.81
        return self.v0*t - 0.5*g*t**2
```

This time the class has only one method and one attribute as we skipped the constructor and let `g` be a local variable in the `value` method.

But if there is no constructor, how is an instance created? Python fortunately creates an empty constructor. This allows us to write

```
y = Y2()
```

to make an instance `y`. Since nothing happens in the automatically generated empty constructor, `y` has no attributes at this stage. Writing

```
print y.v0
```

therefore leads to the exception

```
AttributeError: Y2 instance has no attribute 'v0'
```

By calling

```
v = y.value(0.1, 5)
```

we create an attribute `self.v0` inside the `value` method. In general, we can create any attribute name in any method by just assigning a value to `self.name`. Now trying a

```
print y.v0
```

will print 5. In a new call,

```
v = y.value(0.2)
```

the previous `v0` value (5) is used inside `value` as `self.v0` unless a `v0` argument is specified in the call.

The previous implementation is not foolproof if we fail to initialize `v0`. For example, the code

```
y = Y2()
v = y.value(0.1)
```

will terminate in the `value` method with the exception

```
AttributeError: Y2 instance has no attribute 'v0'
```

As usual, it is better to notify the user with a more informative message. To check if we have an attribute `v0`, we can use the Python function `hasattr`. Calling `hasattr(self, 'v0')` returns `True` only if the instance `self` has an attribute with name `'v0'`. An improved `value` method now reads

```
def value(self, t, v0=None):
    if v0 is not None:
        self.v0 = v0
    if not hasattr(self, 'v0'):
        print 'You cannot call value(t) without first \'
              \'calling value(t,v0) to set v0'
        return None
    g = 9.81
    return self.v0*t - 0.5*g*t**2
```

Alternatively, we can try to access `self.v0` in a `try-except` block, and perhaps raise an exception `TypeError` (which is what Python raises if there are not enough arguments to a function or method):

```
def value(self, t, v0=None):
    if v0 is not None:
        self.v0 = v0
    g = 9.81
    try:
        value = self.v0*t - 0.5*g*t**2
    except AttributeError:
        msg = 'You cannot call value(t) without first '
            'calling value(t,v0) to set v0'
        raise TypeError(msg)
    return value
```

Note that Python detects an `AttributeError`, but from a user's point of view, not enough parameters were supplied in the call so a `TypeError` is more appropriate to communicate back to the calling code.

We think class `Y` is a better implementation than class `Y2`, because the former is simpler. As already mentioned, it is a good habit to include a constructor and set data here rather than “recording data on the fly” as we try to in class `Y2`. The whole purpose of class `Y2` is just to show that Python provides great flexibility with respect to defining attributes, and that there are no requirements to what a class *must* contain.

7.1.5 Making Classes Without the Class Construct

Newcomers to the class concept often have a hard time understanding what this concept is about. The present section tries to explain in more detail how we can introduce classes without having the class construct in the computer language. This information may or may not increase your understanding of classes. If not, programming with classes will definitely increase your understanding with time, so there is no reason to worry. In fact, you may safely jump to Chapter 7.3 as there are no important concepts in this section that later sections build upon.

A class contains a collection of variables (data) and a collection of methods (functions). The collection of variables is unique to each instance of the class. That is, if we make ten instances, each of them has its own set of variables. These variables can be thought of as a dictionary with keys equal to the variable names. Each instance then has its own dictionary, and we may roughly view the instance as this dictionary⁵.

On the other hand, the methods are shared among the instances. We may think of a method in a class as a standard global function that takes an instance in the form of a dictionary as first argument. The method has then access to the variables in the instance (dictionary) provided in the call. For the `Y` class from Chapter 7.1.2 and an instance

⁵ The instance can also contain static class attributes (Chapter 7.6), but these are to be viewed as global variables in the present context.

y, the methods are ordinary functions with the following names and arguments:

```
Y.value(y, t)
Y.formula(y)
```

The class acts as a *namespace*, meaning that all functions must be prefixed by the namespace name, here Y. Two different classes, say C1 and C2, may have functions with the same name, say `value`, but when the `value` functions belong to different namespaces, their names `C1.value` and `C2.value` become distinct. Modules are also namespaces for the functions and variables in them (think of `math.sin`, `cmath.sin`, `numpy.sin`).

The only peculiar thing with the class construct in Python is that it allows us to use an alternative syntax for method calls:

```
y.value(t)
y.formula()
```

This syntax coincides with the traditional syntax of calling class methods and providing arguments, as found in other computer languages, such as Java, C#, C++, Simula, and Smalltalk. The dot notation is also used to access variables in an instance such that we inside a method can write `self.v0` instead of `self['v0']` (`self` refers to `y` through the function call).

We could easily implement a simple version of the class concept without having a class construction in the language. All we need is a dictionary type and ordinary functions. The dictionary acts as the instance, and methods are functions that take this dictionary as the first argument such that the function has access to all the variables in the instance. Our Y class could now be implemented as

```
def value(self, t):
    return self['v0']*t - 0.5*self['g']*t**2

def formula(self):
    print 'v0*t - 0.5*g*t**2; v0=%g' % self['v0']
```

The two functions are placed in a module called Y. The usage goes as follows:

```
import Y
y = {'v0': 4, 'g': 9.81} # make an "instance"
y1 = Y.value(y, t)
```

We have no constructor since the initialization of the variables is done when declaring the dictionary `y`, but we could well include some initialization function in the Y module

```
def init(v0):  
    return {'v0': v0, 'g': 9.81}
```

The usage is now slightly different:

```
import Y  
y = Y.init(4)          # make an "instance"  
y1 = Y.value(y, t)
```

This way of implementing classes with the aid of a dictionary and a set of ordinary functions actually forms the basis for class implementations in many languages. Python and Perl even have a syntax that demonstrates this type of implementation. In fact, every class instance in Python has a dictionary `__dict__` as attribute, which holds all the variables in the instance. Here is a demo that proves the existence of this dictionary in class `Y`:

```
>>> y = Y(1.2)  
>>> print y.__dict__  
{'v0': 1.2, 'g': 9.8100000000000005}
```

To summarize: A Python class can be thought of as some variables collected in a dictionary, and a set of functions where this dictionary is automatically provided as first argument such that functions always have full access to the class variables.

First Remark. We have in this section provided a view of classes *from a technical point of view*. Others may view a class as a way of modeling the world in terms of data and operations on data. However, in sciences that employ the language of mathematics, the modeling of the world is usually done by mathematics, and the mathematical structures provide understanding of the problem and structure of programs. When appropriate, mathematical structures can conveniently be mapped on to classes in programs to make the software simpler and more flexible.

Second Remark. The view of classes in this section neglects very important topics such as inheritance and dynamic binding, which we treat in Chapter 9. For more completeness of the present section, we briefly describe how our combination of dictionaries and global functions can deal with inheritance and dynamic binding (but this will not make sense unless you know what inheritance is).

Data inheritance can be obtained by letting a subclass dictionary do an `update` call with the superclass dictionary as argument. In this way all data in the superclass are also available in the subclass dictionary. Dynamic binding of methods is more complicated, but one can think of checking if the method is in the subclass module (using `hasattr`), and if not, one proceeds with checking super class modules until a version of the method is found.

7.2 More Examples on Classes

The use of classes to solve problems from mathematical and physical sciences may not be so obvious. On the other hand, in many administrative programs for managing interactions between objects in the real world the objects themselves are natural candidates for being modeled by classes. Below we give some examples on what classes can be used to model.

7.2.1 Bank Accounts

The concept of a bank account in a program is a good candidate for a class. The account has some data, typically the name of the account holder, the account number, and the current balance. Three things we can do with an account is withdraw money, put money into the account, and print out the data of the account. These actions are modeled by methods. With a class we can pack the data and actions together into a new data type so that one account corresponds to one variable in a program.

Class `Account` can be implemented as follows:

```
class Account:
    def __init__(self, name, account_number, initial_amount):
        self.name = name
        self.no = account_number
        self.balance = initial_amount

    def deposit(self, amount):
        self.balance += amount

    def withdraw(self, amount):
        self.balance -= amount

    def dump(self):
        s = '%s, %s, balance: %s' % \
            (self.name, self.no, self.balance)
        print s
```

Here is a simple test of how class `Account` can be used:

```
>>> from classes import Account
>>> a1 = Account('John Olsson', '19371554951', 20000)
>>> a2 = Account('Liz Olsson', '19371564761', 20000)
>>> a1.deposit(1000)
>>> a1.withdraw(4000)
>>> a2.withdraw(10500)
>>> a1.withdraw(3500)
>>> print "a1's balance:", a1.balance
a1's balance: 13500
>>> a1.dump()
John Olsson, 19371554951, balance: 13500
>>> a2.dump()
Liz Olsson, 19371564761, balance: 9500
```

The author of this class does not want users of the class to operate on the attributes directly and thereby change the name, the account

number, or the balance. The intention is that users of the class should only call the constructor, the `deposit`, `withdraw`, and `dump` methods, and (if desired) inspect the `balance` attribute, but never change it. Other languages with class support usually have special keywords that can restrict access to class attributes and methods, but Python does not. Either the author of a Python class has to rely on correct usage, or a special convention can be used: Any name starting with an underscore represents an attribute that should never be touched or a method that should never be called. One refers to names starting with an underscore as *protected* names. These can be freely used inside methods in the class, but not outside.

In class `Account`, it is natural to protect access to the `name`, `no`, and `balance` attributes by prefixing these names by an underscore. For *reading* only of the `balance` attribute, we provide a new method `get_balance`. The user of the class should now only call the methods in the class and not access any attributes.

The new “protected” version of class `Account`, called `AccountP`, reads

```
class AccountP:
    def __init__(self, name, account_number, initial_amount):
        self._name = name
        self._no = account_number
        self._balance = initial_amount

    def deposit(self, amount):
        self._balance += amount

    def withdraw(self, amount):
        self._balance -= amount

    def get_balance(self):
        return self._balance

    def dump(self):
        s = '%s, %s, balance: %s' % \
            (self._name, self._no, self._balance)
        print s
```

We can technically access the attributes, but we then break the convention that names starting with an underscore should never be touched outside the class. Here is class `AccountP` in action:

```
>>> a1 = AccountP('John Olsson', '19371554951', 20000)
>>> a1.deposit(1000)
>>> a1.withdraw(4000)
>>> a1.withdraw(3500)
>>> a1.dump()
John Olsson, 19371554951, balance: 13500
>>> print a1._balance          # it works, but a convention is broken
13500
print a1.get_balance()        # correct way of viewing the balance
13500
>>> a1._no = '19371554955'    # this is a "serious crime"
```

Python has a special construct, called *properties*, that can be used to protect attributes from being changed. This is very useful, but the

author considers properties a bit too complicated for this introductory book.

7.2.2 Phone Book

You are probably familiar with the phone book on your mobile phone. The phone book contains a list of persons. For each person you can record the name, telephone numbers, email address, and perhaps other relevant data. A natural way of representing such personal data in a program is to create a class, say class `Person`. The attributes of the class holds data like the name, mobile phone number, office phone number, private phone number, and email address. The constructor may initialize some of the data about a person. Additional data can be specified later by calling methods in the class. One method can print the data. Other methods can register additional telephone numbers and an email address. In addition we initialize some of the attributes in a constructor method. The attributes that are not initialized when constructing a `Person` instance can be added later by calling appropriate methods. For example, adding an office number is done by calling `add_office_number`.

Class `Person` may look as

```
class Person:
    def __init__(self, name,
                 mobile_phone=None, office_phone=None,
                 private_phone=None, email=None):
        self.name = name
        self.mobile = mobile_phone
        self.office = office_phone
        self.private = private_phone
        self.email = email

    def add_mobile_phone(self, number):
        self.mobile = number

    def add_office_phone(self, number):
        self.office = number

    def add_private_phone(self, number):
        self.private = number

    def add_email(self, address):
        self.email = address
```

Note the use of `None` as default value for various attributes: the object `None` is commonly used to indicate that a variable or attribute is defined, but yet not with a sensible value.

A quick demo session of class `Person` may go as follows:

```
>>> p1 = Person('Hans Hanson',
...             office_phone='767828283', email='h@hanshanson.com')
>>> p2 = Person('Ole Olsen', office_phone='767828292')
>>> p2.add_email('olsen@somemail.net')
>>> phone_book = [p1, p2]
```

It can be handy to add a method for printing the contents of a `Person` instance in a nice fashion:

```
def dump(self):
    s = self.name + '\n'
    if self.mobile is not None:
        s += 'mobile phone:  %s\n' % self.mobile
    if self.office is not None:
        s += 'office phone:  %s\n' % self.office
    if self.private is not None:
        s += 'private phone: %s\n' % self.private
    if self.email is not None:
        s += 'email address: %s\n' % self.email
    print s
```

With this method we can easily print the phone book:

```
>>> for person in phone_book:
...     person.dump()
...
Hans Hanson
office phone:  767828283
email address: h@hanshanson.com

Ole Olsen
office phone:  767828292
email address: olsen@somemail.net
```

A phone book can be a list of `Person` instances, as indicated in the examples above. However, if we quickly want to look up the phone numbers or email address for a given name, it would be more convenient to store the `Person` instances in a dictionary with the name as key:

```
>>> phone_book = {'Hanson': p1, 'Olsen': p2}
>>> for person in sorted(phone_book): # alphabetic order
...     phone_book[person].dump()
```

The current example of `Person` objects is extended in Chapter [7.3.5](#).

7.2.3 A Circle

Geometric figures, such as a circle, are other candidates for classes in a program. A circle is uniquely defined by its center point (x_0, y_0) and its radius R . We can collect these three numbers as attributes in a class. The values of x_0 , y_0 , and R are naturally initialized in the constructor. Other methods can be `area` and `circumference` for calculating the area πR^2 and the circumference $2\pi R$:

```
class Circle:
    def __init__(self, x0, y0, R):
        self.x0, self.y0, self.R = x0, y0, R

    def area(self):
        return pi*self.R**2

    def circumference(self):
        return 2*pi*self.R
```

An example of using class `Circle` goes as follows:

```
>>> c = Circle(2, -1, 5)
>>> print 'A circle with radius %g at (%g, %g) has area %g' % \
...      (c.R, c.x0, c.y0, c.area())
A circle with radius 5 at (2, -1) has area 78.5398
```

The ideas of class `Circle` can be applied to other geometric objects as well: rectangles, triangles, ellipses, boxes, spheres, etc. Exercise 7.3 tests if you are able to adapt class `Circle` to a rectangle and a triangle.

Remark. There are usually many solutions to a programming problem. Representing a circle is no exception. Instead of using a class, we could collect x_0 , y_0 , and R in a list and create global functions `area` and `circumference` that take such a list as argument:

```
x0, y0, R = 2, -1, 5
circle = [x0, y0, R]

def area(c):
    R = c[2]
    return pi*R**2

def circumference(c):
    R = c[2]
    return 2*pi*R
```

Alternatively, the circle could be represented by a dictionary with keys `'center'` and `'radius'`:

```
circle = {'center': (2, -1), 'radius': 5}

def area(c):
    R = c['radius']
    return pi*R**2

def circumference(c):
    R = c['radius']
    return 2*pi*R
```

7.3 Special Methods

Some class methods have names starting and ending with a double underscore. These methods allow a special syntax in the program and are called *special methods*. The constructor `__init__` is one example. This method is automatically called when an instance is created (by calling the class as a function), but we do not need to explicitly write `__init__`. Other special methods make it possible to perform arithmetic operations with instances, to compare instances with `>`, `>=`, `!=`, etc., to call instances as we call ordinary functions, and to test if an instance is true or false, to mention some possibilities.

7.3.1 The Call Special Method

Computing the value of the mathematical function represented by class `Y` on page 345, with `y` as the name of the instance, is performed by writing `y.value(t)`. If we could write just `y(t)`, the `y` instance would look as an ordinary function. Such a syntax is indeed possible and offered by the special method named `__call__`. Writing `y(t)` implies a call

```
y.__call__(t)
```

if class `Y` has the method `__call__` defined. We may easily add this special method:

```
class Y:
    ...
    def __call__(self, t):
        return self.v0*t - 0.5*self.g*t**2
```

The previous `value` method is now redundant. A good programming convention is to include a `__call__` method in all classes that represent a mathematical function. Instances with `__call__` methods are said to be *callable* objects, just as plain functions are callable objects as well. The call syntax for callable objects is the same, regardless of whether the object is a function or a class instance. Given an object `a`,

```
if callable(a):
```

tests whether `a` behaves as a callable, i.e., if `a` is a Python function or an instance with a `__call__` method.

In particular, an instance of class `Y` can be passed as the `f` argument to the `diff` function on page 343:

```
y = Y(v0=5)
dydt = diff(y, 0.1)
```

Inside `diff`, we can test that `f` is not a function but an instance of class `Y`. However, we only use `f` in calls, like `f(x)`, and for this purpose an instance with a `__call__` method works as a plain function. This feature is very convenient.

The next section demonstrates a neat application of the call operator `__call__` in a numerical algorithm.

7.3.2 Example: Automatic Differentiation

Problem. Given a Python implementation `f(x)` of a mathematical function $f(x)$, we want to create an object that behaves as a Python function for computing the derivative $f'(x)$. For example, if this object is of type `Derivative`, we should be able to write something like

```
>>> def f(x):
        return x**3
...
>>> dfdx = Derivative(f)
>>> x = 2
>>> dfdx(x)
12.000000992884452
```

That is, `dfdx` behaves as a straight Python function for implementing the derivative $3x^2$ of x^3 (well, the answer is only approximate, with an error in the 7th decimal, but the approximation can easily be improved).

Maple, Mathematica, and many other software packages can do exact symbolic mathematics, including differentiation and integration. A Python package SymPy for symbolic mathematics is free and simple to use, and could easily be applied to calculate the exact derivative of a large class of functions $f(x)$. However, functions that are defined in an algorithmic way (e.g., solution of another mathematical problem), or functions with branches, random numbers, etc., pose fundamental problems to symbolic differentiation, and then numerical differentiation is required. Therefore we base the computation of derivatives in `Derivative` instances on finite difference formulas. This strategy also leads to much simpler code compared to exact symbolic differentiation.

Solution. The most basic, but not the best formula for a numerical derivative is (7.1), which we reuse here for simplicity. The reader can easily switch from this formula to a better one if desired. The idea now is that we make a class to hold the function to be differentiated, call it `f`, and a step size `h` to be used in the numerical approximation. These variables can be set in the constructor. The `__call__` operator computes the derivative with aid of the general formula (7.1). All this can be coded as

```
class Derivative:
    def __init__(self, f, h=1E-5):
        self.f = f
        self.h = float(h)

    def __call__(self, x):
        f, h = self.f, self.h      # make short forms
        return (f(x+h) - f(x))/h
```

Note that we turn `h` into a `float` to avoid potential integer division.

Below follows an application of the class to differentiate two functions $f(x) = \sin x$ and $g(t) = t^3$:

```
>>> from math import sin, cos, pi
>>> df = Derivative(sin)
>>> x = pi
>>> df(x)
-1.000000082740371
>>> cos(x) # exact
-1.0
```

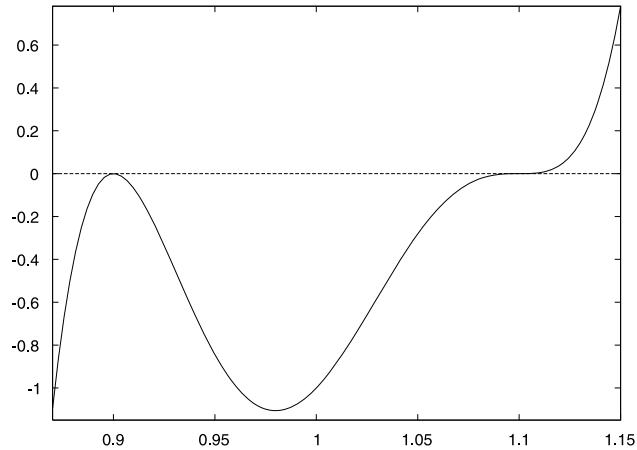



Fig. 7.2 Plot of $y = 10^5(x - 0.9)^2(x - 1.1)^3$.

```
>>> Newton(f, 1.01, df_exact, epsilon=1E-5)
(1.0987610065618421, 8, -7.5139689100699629e-06)
```

This example indicates that there are hardly any drawbacks in using a “smart” inexact general differentiation approach as in the `Derivative` class. The advantages are many – most notably, `Derivative` avoids potential errors from possibly incorrect manual coding of possibly lengthy expressions of possibly wrong hand-calculations. The errors in the involved approximations can be made smaller, usually much smaller than other errors, like the tolerance in Newton’s method in this example or the uncertainty in physical parameters in real-life problems.

7.3.3 Example: Automagic Integration

We can apply the ideas from Chapter 7.3.2 to make a class for computing the integral of a function numerically. Given a function $f(x)$, we want to compute

$$F(x; a) = \int_a^x f(t) dt.$$

The computational technique consists of using the Trapezoidal rule with n intervals ($n + 1$ points):

$$\int_a^x f(t) dt = h \left(\frac{1}{2} f(a) + \sum_{i=1}^{n-1} f(a + ih) + \frac{1}{2} f(x) \right), \quad (7.2)$$

where $h = (x - a)/n$. In an application program, we want to compute $F(x; a)$ by a simple syntax like

```
def f(x):
    return exp(-x**2)*sin(10*x)

a = 0; n = 200
F = Integral(f, a, n)
print F(x)
```

Here, $f(x)$ is the Python function to be integrated, and $F(x)$ behaves as a Python function that calculates values of $F(x; a)$.

A Simple Implementation. Consider a straightforward implementation of the Trapezoidal rule in a Python function:

```
def trapezoidal(f, a, x, n):
    h = (x-a)/float(n)
    I = 0.5*f(a)
    for i in iseq(1, n-1):
        I += f(a + i*h)
    I += 0.5*f(x)
    I *= h
    return I
```

The `iseq` function, offered by `scitools.std`, is an alternative to `range` where the upper limit, here `n-1`, is included in the set of numbers. We can alternatively use `range(1, n)`, but the correspondence with the indices in the mathematical description of the rule is then not one-to-one.

Class `Integral` must have some attributes and a `__call__` method. Since the latter method is supposed to take `x` as argument, the other parameters `a`, `f`, and `n` must be class attributes. The implementation then becomes

```
class Integral:
    def __init__(self, f, a, n=100):
        self.f, self.a, self.n = f, a, n

    def __call__(self, x):
        return trapezoidal(self.f, self.a, x, self.n)
```

Observe that we just reuse the `trapezoidal` function to perform the calculation. We could alternatively have copied the body of the `trapezoidal` function into the `__call__` method. However, if we already have this algorithm implemented and tested as a function, it is better to call the function. The class is then known as a *wrapper* of the underlying function. A wrapper allows something to be called with alternative syntax. With the `Integral(x)` wrapper we can supply the upper limit of the integral only – the other parameters are supplied when we create an instance of the `Integral` class.

An application program computing $\int_0^{2\pi} \sin x dx$ might look as follows:

```
from math import sin, pi
G = Integral(sin, 0, 200)
value = G(2*pi)
```

An equivalent calculation is

```
value = trapezoidal(sin, 0, 2*pi, 200)
```

Remark. Class `Integral` is inefficient (but probably more than fast enough) for plotting $F(x; a)$ as a function x . Exercise 7.28 suggests to optimize the class for this purpose.

7.3.4 Turning an Instance into a String

Another special method is `__str__`. It is called when a class instance needs to be converted to a string. This happens when we say `print a`, and `a` is an instance. Python will then look into the `a` instance for a `__str__` method, which is supposed to return a string. If such a special method is found, the returned string is printed, otherwise just the name of the class is printed. An example will illustrate the point. First we try to print an `y` instance of class `Y` from Chapter 7.1.2 (where there is no `__str__` method):

```
>>> print y
<__main__.Y instance at 0xb751238c>
```

This means that `y` is an `Y` instance in the `__main__` module (the main program or the interactive session). The output also contains an address telling where the `y` instance is stored in the computer's memory.

If we want `print y` to print out the `y` instance, we need to define the `__str__` method in class `Y`:

```
class Y:
    ...
    def __str__(self):
        return 'v0*t - 0.5*g*t**2; v0=%g' % self.v0
```

Typically, `__str__` replaces our previous `formula` method and `__call__` replaces our previous `value` method. Python programmers with the experience that we now have gained will therefore write class `Y` with special methods only:

```
class Y:
    def __init__(self, v0):
        self.v0 = v0
        self.g = 9.81

    def __call__(self, t):
        return self.v0*t - 0.5*self.g*t**2

    def __str__(self):
        return 'v0*t - 0.5*g*t**2; v0=%g' % self.v0
```

Let us see the class in action:

```
>>> y = Y(1.5)
>>> y(0.2)
0.1038
>>> print y
v0*t - 0.5*g*t**2; v0=1.5
```

What have we gained by using special methods? Well, we can still only evaluate the formula and write it out, but many users of the class will claim that the syntax is more attractive since $y(t)$ in code means $y(t)$ in mathematics, and we can do a `print y` to view the formula. The bottom line of using special methods is to achieve a more user-friendly syntax. The next sections illustrate this point further.

7.3.5 Example: Phone Book with Special Methods

Let us reconsider class `Person` from Chapter 7.2.2. The `dump` method in that class is better implemented as a `__str__` special method. This is easy: We just change the method name and replace `print s` by `return s`.

Storing `Person` instances in a dictionary to form a phone book is straightforward. However, we make the dictionary a bit easier to use if we wrap a class around it. That is, we make a class `PhoneBook` which holds the dictionary as an attribute. An `add` method can be used to add a new person:

```
class PhoneBook:
    def __init__(self):
        self.contacts = {} # dict of Person instances

    def add(self, name, mobile=None, office=None,
           private=None, email=None):
        p = Person(name, mobile, office, private, email)
        self.contacts[name] = p
```

A `__str__` can print the phone book in alphabetic order:

```
def __str__(self):
    s = ''
    for p in sorted(self.contacts):
        s += str(self.contacts[p]) + '\n'
    return s
```

To retrieve a `Person` instance, we use the `__call__` with the person's name as argument:

```
def __call__(self, name):
    return self.contacts[name]
```

The only advantage of this method is simpler syntax: For a `PhoneBook` `b` we can get data about `NN` by calling `b('NN')` rather than accessing the internal dictionary `b.contacts['NN']`.

We can make a simple test function for a phone book with three names:

```
b = PhoneBook()
b.add('Ole Olsen', office='767828292',
      email='olsen@somemail.net')
b.add('Hans Hanson',
      office='767828283', mobile='995320221')
b.add('Per Person', mobile='906849781')
print b('Per Person')
print b
```

The output becomes

```
Per Person
mobile phone: 906849781

Hans Hanson
mobile phone: 995320221
office phone: 767828283

Ole Olsen
office phone: 767828292
email address: olsen@somemail.net

Per Person
mobile phone: 906849781
```

You are strongly encouraged to work through this last demo program by hand and simulate what the program does. That is, jump around in the code and write down on a piece of paper what various variables contain after each statement. This is an important and good exercise! You enjoy the happiness of mastering classes if you get the same output as above. The complete program with classes `Person` and `PhoneBook` and the test above is found in the file `PhoneBook.py`. You can run this program, statement by statement, in a debugger (see Appendix F.1) to control that your understanding of the program flow is correct.

Remark. Note that the names are sorted with respect to the first names. The reason is that strings are sorted after the first character, then the second character, and so on. We can supply our own tailored sort function, as explained in Exercise 3.32. One possibility is to split the name into words and use the last word for sorting:

```
def last_name_sort(name1, name2):
    lastname1 = name1.split()[-1]
    lastname2 = name2.split()[-1]
    if lastname1 < lastname2:
        return -1
    elif lastname1 > lastname2:
        return 1
    else: # equality
        return 0

for p in sorted(self.contacts, last_name_sort):
    ...
```

7.3.6 Adding Objects

Let `a` and `b` be instances of some class `C`. Does it make sense to write `a + b`? Yes, this makes sense if class `C` has defined a special method `__add__`:

```
class C:
    ...
    __add__(self, other):
        ...
```

The `__add__` method should add the instances `self` and `other` and return the result as an instance. So when Python encounters `a + b`, it will check if class `C` has an `__add__` method and interpret `a + b` as the call `a.__add__(b)`. The next example will hopefully clarify what this idea can be used for.

7.3.7 Example: Class for Polynomials

Let us create a class `Polynomial` for polynomials. The coefficients in the polynomial can be given to the constructor as a list. Index number i in this list represents the coefficients of the x^i term in the polynomial. That is, writing `Polynomial([1,0,-1,2])` defines a polynomial

$$1 + 0 \cdot x - 1 \cdot x^2 + 2 \cdot x^3 = 1 - x^2 + 2x^3.$$

Polynomials can be added (by just adding the coefficients) so our class may have an `__add__` method. A `__call__` method is natural for evaluating the polynomial, given a value of x . The class is listed below and explained afterwards.

```
class Polynomial:
    def __init__(self, coefficients):
        self.coeff = coefficients

    def __call__(self, x):
        s = 0
        for i in range(len(self.coeff)):
            s += self.coeff[i]*x**i
        return s

    def __add__(self, other):
        # Start with the longest list and add in the other
        if len(self.coeff) > len(other.coeff):
            result_coeff = self.coeff[:] # copy!
            for i in range(len(other.coeff)):
                result_coeff[i] += other.coeff[i]
        else:
            result_coeff = other.coeff[:] # copy!
            for i in range(len(self.coeff)):
                result_coeff[i] += self.coeff[i]
        return Polynomial(result_coeff)
```

Implementation. Class `Polynomial` has one attribute: the list of coefficients. To evaluate the polynomial, we just sum up coefficient no. i times x^i for $i = 0$ to the number of coefficients in the list.

The `__add__` method looks more advanced. The idea is to add the two lists of coefficients. However, it may happen that the lists are of unequal length. We therefore start with the longest list and add in the other list, element by element. Observe that `result_coeff` starts out as a *copy* of `self.coeff`: If not, changes in `result_coeff` as we compute the sum will be reflected in `self.coeff`. This means that `self` would be the sum of itself and the other instance, or in other words, adding two instances, `p1+p2`, changes `p1` – this is not what we want! An alternative implementation of class `Polynomial` is found in Exercise 7.30.

A subtraction method `__sub__` can be implemented along the lines of `__add__`, but is slightly more complicated and left to the reader through Exercise 7.31. A somewhat more complicated operation, from a mathematical point of view, is the multiplication of two polynomials. Let $p(x) = \sum_{i=0}^M c_i x^i$ and $q(x) = \sum_{j=0}^N d_j x^j$ be the two polynomials. The product becomes

$$\left(\sum_{i=0}^M c_i x^i \right) \left(\sum_{j=0}^N d_j x^j \right) = \sum_{i=0}^M \sum_{j=0}^N c_i d_j x^{i+j}.$$

The double sum must be implemented as a double loop, but first the list for the resulting polynomial must be created with length $M + N + 1$ (the highest exponent is $M + N$ and then we need a constant term). The implementation of the multiplication operator becomes

```
def __mul__(self, other):
    c = self.coeff
    d = other.coeff
    M = len(c) - 1
    N = len(d) - 1
    result_coeff = numpy.zeros(M+N+1)
    for i in range(0, M+1):
        for j in range(0, N+1):
            result_coeff[i+j] += c[i]*d[j]
    return Polynomial(result_coeff)
```

We could also include a method for differentiating the polynomial according to the formula

$$\frac{d}{dx} \sum_{i=0}^n c_i x^i = \sum_{i=1}^n i c_i x^{i-1}.$$

If c_i is stored as a list `c`, the list representation of the derivative, say its name is `dc`, fulfills `dc[i-1] = i*c[i]` for i running from 1 to the largest index in `c`. Note that `dc` has one element less than `c`.

There are two different ways of implementing the differentiation functionality, either by changing the polynomial coefficients, or by returning a new `Polynomial` instance from the method such that the original polynomial instance is intact. We let `p.differentiate()` be an implementation of the first approach, i.e., this method does not return anything, but the coefficients in the `Polynomial` instance `p` are altered. The other approach is implemented by `p.derivative()`, which returns a new `Polynomial` object with coefficients corresponding to the derivative of `p`.

The complete implementation of the two methods is given below:

```
def differentiate(self):
    """Differentiate this polynomial in-place."""
    for i in range(1, len(self.coeff)):
        self.coeff[i-1] = i*self.coeff[i]
    del self.coeff[-1]

def derivative(self):
    """Copy this polynomial and return its derivative."""
    dpdx = Polynomial(self.coeff[:]) # make a copy
    dpdx.differentiate()
    return dpdx
```

The `Polynomial` class with a `differentiate` method and not a `derivative` method would be mutable (see Chapter 6.2.3) and allow in-place changes of the data, while the `Polynomial` class with `derivative` and not `differentiate` would yield an immutable object where the polynomial initialized in the constructor is never altered⁷. A good rule is to offer only one of these two functions such that a `Polynomial` object is either mutable or immutable (if we leave out `differentiate`, its function body must of course be copied into `derivative` since `derivative` now relies on that code). However, since the main purpose of this class is to illustrate various types of programming techniques, we keep both versions.

Usage. As a demonstration of the functionality of class `Polynomial`, we introduce the two polynomials

$$p_1(x) = 1 - x, \quad p_2(x) = x - 6x^4 - x^5.$$

```
>>> p1 = Polynomial([1, -1])
>>> p2 = Polynomial([0, 1, 0, 0, -6, -1])
>>> p3 = p1 + p2
>>> print p3.coeff
[1, 0, 0, 0, -6, -1]
>>> p4 = p1*p2
>>> print p4.coeff
[0, 1, -1, 0, -6, 5, 1]
```

⁷ Technically, it is possible to grab the `coeff` variable in a class instance and alter this list. By starting `coeff` with an underscore, a Python programming convention tells programmers that this variable is for internal use in the class only, and not to be altered by users of the instance, see Chapters 7.2.1 and 7.5.2.

```
>>> p5 = p2.derivative()
>>> print p5.coeff
[1, 0, 0, -24, -5]
```

One verification of the implementation may be to compare p_3 at (e.g.) $x = 1/2$ with $p_1(x) + p_2(x)$:

```
>>> x = 0.5
>>> p1_plus_p2_value = p1(x) + p2(x)
>>> p3_value = p3(x)
>>> print p1_plus_p2_value - p3_value
0.0
```

Note that $p_1 + p_2$ is very different from $p_1(x) + p_2(x)$. In the former case, we add two instances of class `Polynomial`, while in the latter case we add two instances of class `float` (since $p_1(x)$ and $p_2(x)$ imply calling `__call__` and that method returns a `float` object).

Pretty Print of Polynomials. The `Polynomial` class can also be equipped with a `__str__` method for printing the polynomial to the screen. A first, rough implementation could simply add up strings of the form `+ self.coeff[i]*x^i`:

```
class Polynomial:
    ...
    def __str__(self):
        s = ''
        for i in range(len(self.coeff)):
            s += ' + %g*x^%d' % (self.coeff[i], i)
        return s
```

However, this implementation leads to ugly output from a mathematical viewpoint. For instance, a polynomial with coefficients $[1,0,0,-1,-6]$ gets printed as

```
+ 1*x^0 + 0*x^1 + 0*x^2 + -1*x^3 + -6*x^4
```

A more desired output would be

```
1 - x^3 - 6*x^4
```

That is, terms with a zero coefficient should be dropped; a part `'+ -'` of the output string should be replaced by `'- '`; unit coefficients should be dropped, i.e., `' 1*'` should be replaced by space `' '`; unit power should be dropped by replacing `'x^1 '` by `'x '`; zero power should be dropped and replaced by 1, initial spaces should be fixed, etc. These adjustments can be implemented using the `replace` method in string objects and by composing slices of the strings. The new version of the `__str__` method below contains the necessary adjustments. If you find this type of string manipulation tricky and difficult to understand, you may safely skip further inspection of the improved `__str__` code since the details are not essential for your present learning about the class concept and special methods.

```
class Polynomial:
    ...
    def __str__(self):
        s = ''
        for i in range(0, len(self.coeff)):
            if self.coeff[i] != 0:
                s += ' + %g*x^%d' % (self.coeff[i], i)
        # Fix layout
        s = s.replace('+ -', '- ')
        s = s.replace('x^0', '1')
        s = s.replace(' 1*', ' ')
        s = s.replace('x^1 ', 'x ')
        if s[0:3] == ' + ': # remove initial +
            s = s[3:]
        if s[0:3] == ' - ': # fix spaces for initial -
            s = '-' + s[3:]
        return s
```

Programming sometimes turns into coding (what one think is) a general solution followed by a series of special cases to fix caveats in the “general” solution, just as we experienced with the `__str__` method above. This situation often calls for additional future fixes and is often a sign of a suboptimal solution to the programming problem.

Pretty print of `Polynomial` instances can be demonstrated in an interactive session:

```
>>> p1 = Polynomial([1, -1])
>>> print p1
1 - x^1
>>> p2 = Polynomial([0, 1, 0, 0, -6, -1])
>>> p2.differentiate()
>>> print p2
1 - 24*x^3 - 5*x^4
```

7.3.8 Arithmetic Operations and Other Special Methods

Given two instances `a` and `b`, the standard binary arithmetic operations with `a` and `b` are defined by the following special methods:

- `a + b` : `a.__add__(b)`
- `a - b` : `a.__sub__(b)`
- `a*b` : `a.__mul__(b)`
- `a/b` : `a.__div__(b)`
- `a**b` : `a.__pow__(b)`

Some other special methods are also often useful:

- the length of `a`, `len(a)`: `a.__len__()`
- the absolute value of `a`, `abs(a)`: `a.__abs__()`
- `a == b` : `a.__eq__(b)`
- `a > b` : `a.__gt__(b)`
- `a >= b` : `a.__ge__(b)`
- `a < b` : `a.__lt__(b)`
- `a <= b` : `a.__le__(b)`

- `a != b : a.__ne__(b)`
- `-a : a.__neg__()`
- evaluating `a` as a boolean expression (as in the test `if a:`) implies calling the special method `a.__bool__()`, which must return `True` or `False` – if `__bool__` is not defined, `__len__` is called to see if the length is zero (`False`) or not (`True`)

We can implement such methods in class `Polynomial`, see Exercise 7.31. Chapter 7.4 contains many examples on using the special methods listed above.

7.3.9 Special Methods for String Conversion

Look at this class with a `__str__` method:

```
>>> class MyClass:
...     def __init__(self):
...         self.data = 2
...     def __str__(self):
...         return 'In __str__: %s' % str(self.data)
...
>>> a = MyClass()
>>> print a
In __str__: 2
```

Hopefully, you understand well why we get this output (if not, go back to Chapter 7.3.4).

But what will happen if we write just `a` at the command prompt in an interactive shell?

```
>>> a
<__main__.MyClass instance at 0xb75125ac>
```

When writing just `a` in an interactive session, Python looks for a special method `__repr__` in `a`. This method is similar to `__str__` in that it turns the instance into a string, but there is a convention that `__str__` is a pretty print of the instance contents while `__repr__` is a complete representation of the contents of the instance. For a lot of Python classes, including `int`, `float`, `complex`, `list`, `tuple`, and `dict`, `__repr__` and `__str__` give identical output. In our class `MyClass` the `__repr__` is missing, and we need to add it if we want

```
>>> a
```

to write the contents like `print a` does.

Given an instance `a`, `str(a)` implies calling `a.__str__()` and `repr(a)` implies calling `a.__repr__()`. This means that

```
>>> a
```

is actually a `repr(a)` call and

```
>>> print a
```

is actually a `print str(a)` statement.

A simple remedy in class `MyClass` is to define

```
def __repr__(self):
    return self.__str__() # or return str(self)
```

However, as we explain below, the `__repr__` is best defined differently.

Recreating Objects from Strings. The Python function `eval(e)` evaluates a valid Python expression contained in the string `e`, see Chapter 4.1.2. It is a convention that `__repr__` returns a string such that `eval` applied to the string recreates the instance. For example, in case of the `Y` class from page 345, `__repr__` should return `'Y(10)'` if the `v0` variable has the value 10. Then `eval('Y(10)')` will be the same as if we had coded `Y(10)` directly in the program or an interactive session.

Below we show examples of `__repr__` methods in classes `Y` (page 345), `Polynomial` (page 369), and `MyClass` (above):

```
class Y:
    ...
    def __repr__(self):
        return 'Y(v0=%s)' % self.v0

class Polynomial:
    ...
    def __repr__(self):
        return 'Polynomial(coefficients=%s)' % self.coeff

class MyClass:
    ...
    def __repr__(self):
        return 'MyClass()'
```

With these definitions, `eval(repr(x))` recreates the object `x` if it is of one of the three types above. In particular, we can write `x` to file and later recreate the `x` from the file information:

```
# somefile is some file object
somefile.write(repr(x))
somefile.close()
...
data = somefile.readline()
x2 = eval(data) # recreate object
```

Now, `x2` will be equal to `x` (`x2 == x` evaluates to true).

7.4 Example: Class for Vectors in the Plane

This section explains how to implement two-dimensional vectors in Python such that these vectors act as objects we can add, subtract,

form inner products with, and do other mathematical operations on. To understand the forthcoming material, it is necessary to have digested Chapter 7.3, in particular Chapters 7.3.6 and 7.3.8.

7.4.1 Some Mathematical Operations on Vectors

Vectors in the plane are described by a pair of real numbers, (a, b) . In Chapter 5.1.2 we presented mathematical rules for adding and subtracting vectors, multiplying two vectors (the inner or dot or scalar product), the length of a vector, and multiplication by a scalar:

$$(a, b) + (c, d) = (a + c, b + d), \quad (7.3)$$

$$(a, b) - (c, d) = (a - c, b - d), \quad (7.4)$$

$$(a, b) \cdot (c, d) = ac + bd, \quad (7.5)$$

$$\|(a, b)\| = \sqrt{(a, b) \cdot (a, b)}. \quad (7.6)$$

Moreover, two vectors (a, b) and (c, d) are equal if $a = c$ and $b = d$.

7.4.2 Implementation

We may create a class for plane vectors where the above mathematical operations are implemented by special methods. The class must contain two attributes, one for each component of the vector, called `x` and `y` below. We include special methods for addition, subtraction, the scalar product (multiplication), the absolute value (length), comparison of two vectors (`==` and `!=`), as well as a method for printing out a vector.

```
class Vec2D:
    def __init__(self, x, y):
        self.x = x
        self.y = y

    def __add__(self, other):
        return Vec2D(self.x + other.x, self.y + other.y)

    def __sub__(self, other):
        return Vec2D(self.x - other.x, self.y - other.y)

    def __mul__(self, other):
        return self.x*other.x + self.y*other.y

    def __abs__(self):
        return math.sqrt(self.x**2 + self.y**2)

    def __eq__(self, other):
        return self.x == other.x and self.y == other.y

    def __str__(self):
        return '%g, %g' % (self.x, self.y)

    def __ne__(self, other):
        return not self.__eq__(other) # reuse __eq__
```

The `__add__`, `__sub__`, `__mul__`, `__abs__`, and `__eq__` methods should be quite straightforward to understand from the previous mathematical definitions of these operations. The last method deserves a comment: Here we simply reuse the equality operator `__eq__`, but precede it with a `not`. We could also have implemented this method as

```
def __ne__(self, other):
    return self.x != other.x or self.y != other.y
```

Nevertheless, this implementation requires us to write more, and it has the danger of introducing an error in the logics of the boolean expressions. A more reliable approach, when we know that the `__eq__` method works, is to reuse this method and observe that “`not ==`” gives us the effect of “`!=`”.

A word of warning is in place regarding our implementation of the equality operator (`==` via `__eq__`). We test for equality of each component, which is correct from a mathematical point of view. However, each vector component is a floating-point number that may be subject to round-off errors both in the representation on the computer and from previous (inexact) floating-point calculations. Two mathematically equal components may be different in their inexact representations on the computer. The remedy for this problem is to avoid testing for equality, but instead check that the difference between the components is sufficiently small. The function `float_eq` found in the module `scitools.numpyutils` (if you do not already have `float_eq` from a `from scitools.std import *`), see also Exercise 2.24, is an easy-to-use tool for comparing `float` objects. With this function we replace

```
if a == b:
```

by

```
if float_eq(a, b):
```

A more reliable equality operator can now be implemented:

```
class Vec2D:
    ...
    def __eq__(self, other):
        return float_eq(self.x, other.x) and \
               float_eq(self.y, other.y)
```

As a rule of thumb, you should never apply the `==` test to two `float` objects.

The special method `__len__` could be introduced as a synonym for `__abs__`, i.e., for a `Vec2D` instance named `v`, `len(v)` is the same as `abs(v)`, because the absolute value of a vector is mathematically the same as the length of the vector. However, if we implement

```
def __len__(self):
    # Reuse implementation of __abs__
    return abs(self) # equiv. to self.__abs__()
```

we will run into trouble when we compute `len(v)` and the answer is (as usual) a `float`. Python will then complain and tell us that `len(v)` must return an `int`. Therefore, `__len__` cannot be used as a synonym for the length of the vector in our application. On the other hand, we could let `len(v)` mean the number of components in the vector:

```
def __len__(self):
    return 2
```

This is not a very useful function, though, as we already know that all our `Vec2D` vectors have just two components. For generalizations of the class to vectors with n components, the `__len__` method is of course useful.

7.4.3 Usage

Let us play with some `Vec2D` objects:

```
>>> u = Vec2D(0,1)
>>> v = Vec2D(1,0)
>>> w = Vec2D(1,1)
>>> a = u + v
>>> print a
(1, 1)
>>> a == w
True
>>> a = u - v
>>> print a
(-1, 1)
>>> a = u*v
>>> print a
0
>>> print abs(u)
1.0
>>> u == v
False
>>> u != v
True
```

When you read through this interactive session, you should check that the calculation is mathematically correct, that the resulting object type of a calculation is correct, and how each calculation is performed in the program. The latter topic is investigated by following the program flow through the class methods. As an example, let us consider the expression `u != v`. This is a boolean expression that is true since `u` and `v` are different vectors. The resulting object type should be `bool`, with values `True` or `False`. This is confirmed by the output in the interactive session above. The Python calculation of `u != v` leads to a call to

```
u.__ne__(v)
```

which leads to a call to

```
u.__eq__(v)
```

The result of this last call is `False`, because the special method will evaluate the boolean expression

```
0 == 1 and 1 == 0
```

which is obviously `False`. When going back to the `__ne__` method, we end up with a return of `not False`, which evaluates to `True`. You need this type of thorough understanding to find and correct bugs (and remember that the first versions of your programs will normally contain bugs!).

Comment. For real computations with vectors in the plane, you would probably just use a Numerical Python array of length 2. However, one thing such objects cannot do is evaluating $u*v$ as a scalar product. The multiplication operator for Numerical Python arrays is not defined as a scalar product (it is rather defined as $(a, b) \cdot (c, d) = (ac, bd)$). Another difference between our `Vec2D` class and Numerical Python arrays is the `abs` function, which computes the length of the vector in class `Vec2D`, while it does something completely different with Numerical Python arrays.

7.5 Example: Class for Complex Numbers

Imagine that Python did not already have complex numbers. We could then make a class for such numbers and support the standard mathematical operations. This exercise turns out to be a very good pedagogical example of programming with classes and special methods.

The class must contain two attributes: the real and imaginary part of the complex number. In addition, we would like to add, subtract, multiply, and divide complex numbers. We would also like to write out a complex number in some suitable format. A session involving our own complex numbers may take the form

```
>>> u = Complex(2,-1)
>>> v = Complex(1)      # zero imaginary part
>>> w = u + v
>>> print w
(3, -1)
>>> w != u
True
>>> u*v
Complex(2, -1)
>>> u < v
```

```

illegal operation "<" for complex numbers
>>> print w + 4
(7, -1)
>>> print 4 - w
(1, 1)

```

We do not manage to use exactly the same syntax with `j` as imaginary unit as in Python's built-in complex numbers so to specify a complex number we must create a `Complex` instance.

7.5.1 Implementation

Here is the complete implementation of our class for complex numbers:

```

class Complex:
    def __init__(self, real, imag=0.0):
        self.real = real
        self.imag = imag

    def __add__(self, other):
        return Complex(self.real + other.real,
                        self.imag + other.imag)

    def __sub__(self, other):
        return Complex(self.real - other.real,
                        self.imag - other.imag)

    def __mul__(self, other):
        return Complex(self.real*other.real - self.imag*other.imag,
                        self.imag*other.real + self.real*other.imag)

    def __div__(self, other):
        sr, si, or, oi = self.real, self.imag, \
                          other.real, other.imag # short forms
        r = float(or**2 + oi**2)
        return Complex((sr*or+si*oi)/r, (si*or-sr*oi)/r)

    def __abs__(self):
        return sqrt(self.real**2 + self.imag**2)

    def __neg__(self): # defines -c (c is Complex)
        return Complex(-self.real, -self.imag)

    def __eq__(self, other):
        return self.real == other.real and self.imag == other.imag

    def __ne__(self, other):
        return not self.__eq__(other)

    def __str__(self):
        return '%g, %g' % (self.real, self.imag)

    def __repr__(self):
        return 'Complex' + str(self)

    def __pow__(self, power):
        raise NotImplementedError\
            ('self**power is not yet impl. for Complex')

```

The special methods for addition, subtraction, multiplication, division, and the absolute value follow easily from the mathematical definitions

of these operations for complex numbers (see Chapter 1.6). What `-c` means when `c` is of type `Complex`, is also easy to define and implement. The `__eq__` method needs a word of caution: The method is mathematically correct, but as we stated on page 377, comparison of real numbers on a computer should always employ a tolerance. The version of `__eq__` shown above is more about compact code and equivalence to the mathematics than real-world numerical computations.

The final `__pow__` method exemplifies a way to introduce a method in a class, while we postpone its implementation. The simplest way to do this is by inserting an empty function body using the `pass` (“do nothing”) statement:

```
def __pow__(self, power):
    # Postpone implementation of self**power
    pass
```

However, the preferred method is to raise a `NotImplementedError` exception so that users writing power expressions are notified that this operation is not available. The simple `pass` will just silently bypass this serious fact!

7.5.2 Illegal Operations

Some mathematical operations, like the comparison operators `>`, `>=`, etc., do not have a meaning for complex numbers. By default, Python allows us to use these comparison operators for our `Complex` instances, but the boolean result will be mathematical nonsense. Therefore, we should implement the corresponding special methods and give a sensible error message that the operations are not available for complex numbers. Since the messages are quite similar, we make a separate method to gather common operations:

```
def _illegal(self, op):
    print 'illegal operation "%s" for complex numbers' % op
```

Note the underscore prefix: This is a Python convention telling that the `_illegal` method is local to the class in the sense that it is not supposed to be used outside the class, just by other class methods. In computer science terms, we say that names starting with an underscore are not part of the *application programming interface*, known as the API. Other programming languages, such as Java, C++, and C#, have special keywords, like `private` and `protected` that can be used to technically hide both data and methods from users of the class. Python will never restrict anybody who tries to access data or methods that are considered private to the class, but the leading underscore in the name reminds any user of the class that she now touches parts of the class that are not meant to be used “from the outside”.

Various special methods for comparison operators can now call up `_illegal` to issue the error message:

```
def __gt__(self, other): self._illegal('>')
def __ge__(self, other): self._illegal('>=')
def __lt__(self, other): self._illegal('<')
def __le__(self, other): self._illegal('<=')
```

7.5.3 Mixing Complex and Real Numbers

The implementation of class `Complex` is far from perfect. Suppose we add a complex number and a real number, which is a mathematically perfectly valid operation:

```
w = u + 4.5
```

This statement leads to an exception,

```
AttributeError: 'float' object has no attribute 'real'
```

In this case, Python sees `u + 4.5` and tries to use `u.__add__(4.5)`, which causes trouble because the `other` argument in the `__add__` method is 4.5, i.e., a `float` object, and `float` objects do not contain an attribute with the name `real` (`other.real` is used in our `__add__` method, and accessing `other.real` is what causes the error).

One idea for a remedy could be to set

```
other = Complex(other)
```

since this construction turns a real number `other` into a `Complex` object. However, when we add two `Complex` instances, `other` is of type `Complex`, and the constructor simply stores this `Complex` instance as `self.real` (look at the method `__init__`). This is not what we want!

A better idea is to test for the type of `other` and perform the right conversion to `Complex`:

```
def __add__(self, other):
    if isinstance(other, (float,int)):
        other = Complex(other)
    return Complex(self.real + other.real,
                  self.imag + other.imag)
```

We could alternatively drop the conversion of `other` and instead implement two addition rules, depending on the type of `other`:

```
def __add__(self, other):
    if isinstance(other, (float,int)):
        return Complex(self.real + other, self.imag)
    else:
        return Complex(self.real + other.real,
                       self.imag + other.imag)
```

A third way is to look for what we require from the `other` object, and check that this demand is fulfilled. Mathematically, we require `other` to be a complex or real number, but from a programming point of view, all we demand (in the original `__add__` implementation) is that `other` has `real` and `imag` attributes. To check if an object `a` has an attribute with name stored in the string `attr`, one can use the function

```
hasattr(a, attr)
```

In our context, we need to perform the test

```
if hasattr(other, 'real') and hasattr(other, 'imag'):
```

Our third implementation of the `__add__` method therefore becomes

```
def __add__(self, other):
    if isinstance(other, (float,int)):
        other = Complex(other)
    elif not (hasattr(other, 'real') and \
              hasattr(other, 'imag')):
        raise TypeError('other must have real and imag attr.')
```

```
    return Complex(self.real + other.real,
                   self.imag + other.imag)
```

The advantage with this third alternative is that we may add instances of class `Complex` and Python's own complex class (`complex`), since all we need is an object with `real` and `imag` attributes.

Computer Science Discussion. The presentations of alternative implementations of the `__add__` actually touch some very important computer science topics. In Python, function arguments can refer to objects of any type, and the type of an argument can change during program execution. This feature is known as *dynamic typing* and supported by languages such as Python, Perl, Ruby, and Tcl. Many other languages, C, C++, Java, and C# for instance, restrict a function argument to be of one type, which must be known when we write the program. Any attempt to call the function with an argument of another type is flagged as an error. One says that the language employs *static typing*, since the type cannot change as in languages having dynamic typing. The code snippet

```
a = 6    # a is integer
a = 'b'  # a is string
```

is valid in a language with dynamic typing, but not in a language with static typing.

Our next point is easiest illustrated through an example. Consider the code

```
a = 6
b = '9'
c = a + b
```

The expression `a + b` adds an integer and a string, which is illegal in Python. However, since `b` is the string `'9'`, it is natural to interpret `a + b` as `6 + 9`. That is, if the string `b` is converted to an integer, we may calculate `a + b`. Languages performing this conversion automatically are said to employ *weak typing*, while languages that require the programmer to explicitly perform the conversion, as in

```
c = a + float(b)
```

are known to have *strong typing*. Python, Java, C, and C# are examples of languages with strong typing, while Perl and C++ allow weak typing. However, in our third implementation of the `__add__` method, certain types – `int` and `float` – are automatically converted to the right type `Complex`. The programmer has therefore imposed a kind of weak typing in the behavior of the addition operation for complex numbers.

There is also something called *duck typing* where the language only imposes a requirement of some data or methods in the object. The explanation of the term duck typing is the principle: “if it walks like a duck, and quacks like a duck, it’s a duck”. An operation `a + b` may be valid if `a` and `b` have certain properties that make it possible to add the objects, regardless of the type of `a` or `b`. To enable `a + b` it is in our third implementation of the `__add__` method sufficient that `b` has `real` and `imag` attributes. That is, objects with `real` and `imag` look like `Complex` objects. Whether they really are of type `Complex` is not considered important in this context.

There is a continuously ongoing debate in computer science which kind of typing that is preferable: dynamic versus static, and weak versus strong. Static and strong typing, as found in Java and C#, support coding safety and reliability at the expense of long and sometimes repetitive code, while dynamic and weak typing support programming flexibility and short code. Many will argue that short code is more reliable than long code, so there is no simple conclusion.

7.5.4 Special Methods for “Right” Operands

What happens if we add a `float` and a `Complex` in that order?

```
w = 4.5 + u
```

This statement causes the exception

```
TypeError: unsupported operand type(s) for +: 'float' and 'instance'
```

This time Python cannot find any definition of what the plus operation means with a `float` on the left-hand side and a `Complex` object on the right-hand side of the plus sign. The `float` class was created many years ago without any knowledge of our `Complex` objects, and we are not allowed to extend the `__add__` method in the `float` class to handle `Complex` instances. Nevertheless, Python has a special method `__radd__` for the case where the class instance (`self`) is on the right-hand side of the operator and the other object is on the left-hand side. That is, we may implement a possible `float` or `int` plus a `Complex` by

```
def __radd__(self, other):      # defines other + self
    return self.__add__(other) # other + self = self + other
```

Similar special methods exist for subtraction, multiplication, and division. For the subtraction operator we need to be a little careful because `other - self`, which is the operation assumed to be implemented in `__rsub__`, is not the same as `self.__sub__(other)` (i.e., `self - other`). A possible implementation is

```
def __sub__(self, other):
    print 'in sub, self=%s, other=%s' % (self, other)
    if isinstance(other, (float,int)):
        other = Complex(other)
    return Complex(self.real - other.real,
                  self.imag - other.imag)

def __rsub__(self, other):
    print 'in rsub, self=%s, other=%s' % (self, other)
    if isinstance(other, (float,int)):
        other = Complex(other)
    return other.__sub__(self)
```

The print statements are inserted to better understand how these methods are visited. A quick test demonstrates what happens:

```
>>> w = u - 4.5
in sub, self=(2, -1), other=4.5
>>> print w
(-2.5, -1)
>>> w = 4.5 - u
in rsub, self=(2, -1), other=4.5
in sub, self=(4.5, 0), other=(2, -1)
>>> print w
(2.5, 1)
```

Remark. As you probably realize, there is quite some code to be implemented and lots of considerations to be resolved before we have a class `Complex` for professional use in the real world. Fortunately, Python provides its `complex` class, which offers everything we need for computing with complex numbers. This fact reminds us that it is important to know what others already have implemented, so that we avoid “reinventing the wheel”. In a learning process, however, it is a probably a very good idea to look into the details of a class `Complex` as we did above.

7.5.5 Inspecting Instances

The purpose of this section is to explain how we can easily look at the contents of a class instance, i.e., the data attributes and the methods. As usual, we look at an example – this time involving a very simple class:

```
class A:
    """A class for demo purposes."""
    def __init__(self, value):
        self.v = value

    def dump(self):
        print self.__dict__
```

The `self.__dict__` attribute is briefly mentioned in Chapter 7.1.5. Every instance is automatically equipped with this attribute, which is a dictionary that stores all the ordinary attributes of the instance (the variable names are keys, and the object references are values). In class `A` there is only one attribute, so the `self.__dict__` dictionary contains one key, `'v'`:

```
>>> a = A([1,2])
>>> a.dump()
{'v': [1, 2]}
```

Another way of inspecting what an instance `a` contains is to call `dir(a)`. This Python function writes out the names of all methods and variables (and more) of an object:

```
>>> dir(a)
['__doc__', '__init__', '__module__', 'dump', 'v']
```

The `__doc__` variable is a docstring, similar to docstrings in functions (Chapter 3.1.7), i.e., a description of the class appearing as a first string right after the `class` headline:

```
>>> a.__doc__
'A class for demo purposes.'
```

The `__module__` variable holds the name of the module in which the class is defined. If the class is defined in the program itself and not in an imported module, `__module__` equals `'__main__'`.

The rest of the entries in the list returned from `dir(a)` correspond to method and attribute names defined by the programmer of the class, in this example the methods `__init__` and `dump`, and the attribute `v`.

Now, let us try to add new variables to an existing instance⁸:

⁸ This may sound scary and highly illegal to C, C++, Java, and C# programmers, but it is natural and legal in many other languages – and sometimes even useful.

```
>>> a.myvar = 10
>>> a.dump()
{'myvar': 10, 'v': [1, 2]}
>>> dir(a)
['_doc__', '__init__', '__module__', 'dump', 'myvar', 'v']
```

The output of `a.dump()` and `dir(a)` show that we were successful in adding a new variable to this instance on the fly. If we make a new instance, it contains only the variables and methods that we find in the definition of class A:

```
>>> b = A(-1)
>>> b.dump()
{'v': -1}
>>> dir(b)
['_doc__', '__init__', '__module__', 'dump', 'v']
```

We may also add new methods to an instance, but this will not be shown here. The primary message of this subsection is two-fold: (i) a class instance is dynamic and allows attributes to be added or removed while the program is running, and (ii) the contents of an instance can be inspected by the `dir` function, and the data attributes are available through the `__dict__` dictionary.

7.6 Static Methods and Attributes

Up to now, each instance has its own copy of attributes. Sometimes it can be natural to have attributes that are shared among all instances. For example, we may have an attribute that counts how many instances that have been made so far. We can exemplify how to do this in a little class for points (x, y, z) in space:

```
>>> class SpacePoint:
...     counter = 0
...     def __init__(self, x, y, z):
...         self.p = (x, y, z)
...         SpacePoint.counter += 1
```

The `counter` attribute is initialized at the same indentation level as the methods in the class, and the attribute is not prefixed by `self`. Such attributes declared outside methods are shared among all instances and called *static attributes*. To access the `counter` attribute, we must prefix by the classname `SpacePoint` instead of `self: SpacePoint.counter`. In the constructor we increase this common counter by 1, i.e., every time a new instance is made the counter is updated to keep track of how many objects we have created so far:

```
>>> p1 = SpacePoint(0,0,0)
>>> SpacePoint.counter
1
```

```
>>> for i in range(400):
...     p = SpacePoint(i*0.5, i, i+1)
...
>>> SpacePoint.counter
401
```

The methods we have seen so far must be called through an instance, which is fed in as the `self` variable in the method. We can also make class methods that can be called without having an instance. The method is then similar to a plain Python function, except that it is contained inside a class and the method name must be prefixed by the classname. Such methods are known as *static methods*. Let us illustrate the syntax by making a very simple class with just one static method `write`:

```
>>> class A:
...     @staticmethod
...     def write(message):
...         print message
...
>>> A.write('Hello!')
Hello!
```

As demonstrated, we can call `write` without having any instance of class `A`, we just prefix with the class name. Also note that `write` does not take a `self` argument. Since this argument is missing inside the method, we can never access non-static attributes since these always must be prefixed by an instance (i.e., `self`). However, we can access static attributes, prefixed by the classname.

If desired, we can make an instance and call `write` through that instance too:

```
>>> a = A()
>>> a.write('Hello again')
Hello again
```

Static methods are used when you want a global function, but find it natural to let the function belong to a class and be prefixed with the classname.

7.7 Summary

7.7.1 Chapter Topics

Classes. A class contains attributes (variables) and methods. A first rough overview of a class can be to just list the attributes and methods in a UML diagram as we have done in Figure 7.3 on page 390 for some of the key classes in the present chapter.

Below is a sample class with three attributes (`m`, `M`, and `G`) and three methods (a constructor, `force`, and `visualize`). The class represents

the gravity force between two masses. This force is computed by the `force` method, while the `visualize` method plots the force as a function of the distance between the masses.

```
class Gravity:
    """Gravity force between two physical objects."""

    def __init__(self, m, M):
        self.m = m          # mass of object 1
        self.M = M          # mass of object 2
        self.G = 6.67428E-11 # gravity constant, m**3/kg/s**2

    def force(self, r):
        G, m, M = self.G, self.m, self.M
        return G*m*M/r**2

    def visualize(self, r_start, r_stop, n=100):
        from scitools.std import plot, linspace
        r = linspace(r_start, r_stop, n)
        g = self.force(r)
        title='Gravity force: m=%g, M=%g' % (self.m, self.M)
        plot(r, g, title=title)
```

Note that to access attributes inside the `force` method, and to call the `force` method inside the `visualize` method, we must prefix with `self`. Also recall that all methods must take `self`, “this” instance, as first argument, but the argument is left out in calls. The assignment of attributes to a local variable (e.g., `G = self.G`) inside methods is not necessary, but here it makes the mathematical formula easier to read and compare with standard mathematical notation.

This class (found in file `Gravity.py`) can be used to find the gravity force between the Moon and the Earth:

```
mass_moon = 7.35E+22; mass_earth = 5.97E+24
gravity = Gravity(mass_moon, mass_earth)
r = 3.85E+8 # Earth-Moon distance in meters
Fg = gravity.force(r)
print 'force:', Fg
```

Special Methods. A collection of special methods, with two leading and trailing underscores in the method names, offers special syntax in Python programs. Table 7.1 on page 390 provides an overview of the most important special methods.

7.7.2 Example: Interval Arithmetics

Input data to mathematical formulas are often subject to uncertainty, usually because physical measurements of many quantities involve measurement errors, or because it is difficult to measure a parameter and one is forced to make a qualified guess of the value instead. In such cases it could be more natural to specify an input parameter by an interval $[a, b]$, which is guaranteed to contain the true value of the parameter. The size of the interval expresses the uncertainty in this parameter.

Table 7.1 Summary of some important special methods in classes. `a` and `b` are instances of the class whose name we set to `A`.

<code>a.__init__(self, args)</code>	constructor: <code>a = A(args)</code>
<code>a.__call__(self, args)</code>	call as function: <code>a(args)</code>
<code>a.__str__(self)</code>	pretty print: <code>print a, str(a)</code>
<code>a.__repr__(self)</code>	representation: <code>a = eval(repr(a))</code>
<code>a.__add__(self, b)</code>	<code>a + b</code>
<code>a.__sub__(self, b)</code>	<code>a - b</code>
<code>a.__mul__(self, b)</code>	<code>a*b</code>
<code>a.__div__(self, b)</code>	<code>a/b</code>
<code>a.__radd__(self, b)</code>	<code>b + a</code>
<code>a.__rsub__(self, b)</code>	<code>b - a</code>
<code>a.__rmul__(self, b)</code>	<code>b*a</code>
<code>a.__rdiv__(self, b)</code>	<code>b/a</code>
<code>a.__pow__(self, p)</code>	<code>a**p</code>
<code>a.__lt__(self, b)</code>	<code>a < b</code>
<code>a.__gt__(self, b)</code>	<code>a > b</code>
<code>a.__le__(self, b)</code>	<code>a <= b</code>
<code>a.__ge__(self, b)</code>	<code>a >= b</code>
<code>a.__eq__(self, b)</code>	<code>a == b</code>
<code>a.__ne__(self, b)</code>	<code>a != b</code>
<code>a.__bool__(self)</code>	boolean expression, as in <code>if a:</code>
<code>a.__len__(self)</code>	length of <code>a</code> (int): <code>len(a)</code>
<code>a.__abs__(self)</code>	<code>abs(a)</code>

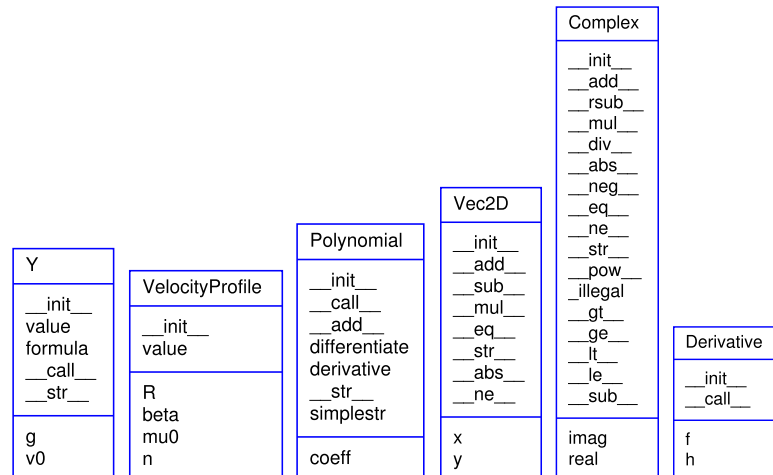
**Fig. 7.3** UML diagrams of some classes described in this chapter.

Suppose all input parameters are specified as intervals, what will be the interval, i.e., the uncertainty, of the output data from the formula? This section develops a tool for computing this output uncertainty in the cases where the overall computation consists of the standard arithmetic operations.

To be specific, consider measuring the acceleration of gravity by dropping a ball and recording the time it takes to reach the ground. Let the ground correspond to $y = 0$ and let the ball be dropped from

$y = y_0$. The position of the ball, $y(t)$, is then⁹

$$y(t) = y_0 - \frac{1}{2}gt^2.$$

If T is the time it takes to reach the ground, we have that $y(T) = 0$, which gives the equation $\frac{1}{2}gT^2 = y_0$, with solution

$$g = 2y_0T^{-2}.$$

In such experiments we always introduce some measurement error in the start position y_0 and in the time taking (T). Suppose y_0 is known to lie in $[0.99, 1.01]$ m and T in $[0.43, 0.47]$ s, reflecting a 2% measurement error in position and a 10% error from using a stop watch. What is the error in g ? With the tool to be developed below, we can find that there is a 22% error in g .

Problem. Assume that two numbers p and q are guaranteed to lie inside intervals,

$$p = [a, b], \quad q = [c, d].$$

The sum $p + q$ is then guaranteed to lie inside an interval $[s, t]$ where $s = a + c$ and $t = b + d$. Below we list the rules of *interval arithmetics*, i.e., the rules for addition, subtraction, multiplication, and division of two intervals:

1. $p + q = [a + c, b + d]$
2. $p - q = [a - d, b - c]$
3. $pq = [\min(ac, ad, bc, bd), \max(ac, ad, bc, bd)]$
4. $p/q = [\min(a/c, a/d, b/c, b/d), \max(a/c, a/d, b/c, b/d)]$ provided that $[c, d]$ does not contain zero

For doing these calculations in a program, it would be natural to have a new type for quantities specified by intervals. This new type should support the operators $+$, $-$, $*$, and $/$ according to the rules above. The task is hence to implement a class for interval arithmetics with special methods for the listed operators. Using the class, we should be able to estimate the uncertainty of two formulas:

1. The acceleration of gravity, $g = 2y_0T^{-2}$, given a 2% uncertainty in y_0 : $y_0 = [0.99, 1.01]$, and a 10% uncertainty in T : $T = [T_m \cdot 0.95, T_m \cdot 1.05]$, with $T_m = 0.45$.
2. The volume of a sphere, $V = \frac{4}{3}\pi R^3$, given a 20% uncertainty in R : $R = [R_m \cdot 0.9, R_m \cdot 1.1]$, with $R_m = 6$.

Solution. The new type is naturally realized as a class `IntervalMath` whose data consist of the lower and upper bound of the interval. Special methods are used to implement arithmetic operations and printing of

⁹ The formula arises from the solution of Exercise 1.13 when $v_0 = 0$.

the object. Having understood class `Vec2D` from Chapter 7.4, it should be straightforward to understand the class below:

```
class IntervalMath:
    def __init__(self, lower, upper):
        self.lo = float(lower)
        self.up = float(upper)

    def __add__(self, other):
        a, b, c, d = self.lo, self.up, other.lo, other.up
        return IntervalMath(a + c, b + d)

    def __sub__(self, other):
        a, b, c, d = self.lo, self.up, other.lo, other.up
        return IntervalMath(a - d, b - c)

    def __mul__(self, other):
        a, b, c, d = self.lo, self.up, other.lo, other.up
        return IntervalMath(min(a*c, a*d, b*c, b*d),
                             max(a*c, a*d, b*c, b*d))

    def __div__(self, other):
        a, b, c, d = self.lo, self.up, other.lo, other.up
        # [c,d] cannot contain zero:
        if c*d <= 0:
            raise ValueError\
                ('Interval %s cannot be denominator because '\
                 'it contains zero')
        return IntervalMath(min(a/c, a/d, b/c, b/d),
                             max(a/c, a/d, b/c, b/d))

    def __str__(self):
        return ' [%g, %g]' % (self.lo, self.up)
```

The code of this class is found in the file `IntervalMath.py`. A quick demo of the class can go as

```
I = IntervalMath
a = I(-3,-2)
b = I(4,5)
expr = 'a+b', 'a-b', 'a*b', 'a/b'
for e in expr:
    print '%s =' % e, eval(e)
```

The output becomes

```
a+b = [1, 3]
a-b = [-8, -6]
a*b = [-15, -8]
a/b = [-0.75, -0.4]
```

This gives the impression that with very short code we can provide a new type that enables computations with interval arithmetics and thereby with uncertain quantities. However, the class above has severe limitations as shown next.

Consider computing the uncertainty of aq if a is expressed as an interval $[4, 5]$ and q is a number (`float`):

```
a = I(4,5)
q = 2
b = a*q
```

This does not work so well:

```
File "IntervalMath.py", line 15, in __mul__
    a, b, c, d = self.lo, self.up, other.lo, other.up
AttributeError: 'float' object has no attribute 'lo'
```

The problem is that $a*q$ is a multiplication between an `IntervalMath` object `a` and a `float` object `q`. The `__mul__` method in class `IntervalMath` is invoked, but the code there tries to extract the `lo` attribute of `q`, which does not exist since `q` is a `float`.

We can extend the `__mul__` method and the other methods for arithmetic operations to allow for a number as operand – we just convert the number to an interval with the same lower and upper bounds:

```
def __mul__(self, other):
    if isinstance(other, (int, float)):
        other = IntervalMath(other, other)
    a, b, c, d = self.lo, self.up, other.lo, other.up
    return IntervalMath(min(a*c, a*d, b*c, b*d),
                        max(a*c, a*d, b*c, b*d))
```

Looking at the formula $g = 2y_0T^{-2}$, we run into a related problem: now we want to multiply 2 (`int`) with y_0 , and if y_0 is an interval, this multiplication is not defined among `int` objects. To handle this case, we need to implement an `__rmul__(self, other)` method for doing `other*self`, as explained in Chapter 7.5.4:

```
def __rmul__(self, other):
    if isinstance(other, (int, float)):
        other = IntervalMath(other, other)
    return other*self
```

Similar methods for addition, subtraction, and division must also be included in the class.

Returning to $g = 2y_0T^{-2}$, we also have a problem with T^{-2} when T is an interval. The expression `T**(-2)` invokes the power operator (at least if we do not rewrite the expression as `1/(T*T)`), which requires a `__pow__` method in class `IntervalMath`. We limit the possibility to have integer powers, since this is easy to compute by repeated multiplications:

```
def __pow__(self, exponent):
    if isinstance(exponent, int):
        p = 1
        if exponent > 0:
            for i in range(exponent):
                p = p*self
        elif exponent < 0:
            for i in range(-exponent):
                p = p*self
            p = 1/p
        else: # exponent == 0
            p = IntervalMath(1, 1)
        return p
    else:
        raise TypeError('exponent must int')
```

Another natural extension of the class is the possibility to convert an interval to a number by choosing the midpoint of the interval:

```
>>> a = IntervalMath(5,7)
>>> float(a)
6
```

`float(a)` calls `a.__float__()`, which we implement as

```
def __float__(self):
    return 0.5*(self.lo + self.up)
```

A `__repr__` method returning the right syntax for recreating the present instance is also natural to include in any class:

```
def __repr__(self):
    return '%s(%g, %g)' % \
        (self.__class__.__name__, self.lo, self.up)
```

We are now in a position to test out the extended class `IntervalMath`.

```
>>> g = 9.81
>>> y_0 = I(0.99, 1.01)      # 2% uncertainty
>>> Tm = 0.45                # mean T
>>> T = I(Tm*0.95, Tm*1.05) # 10% uncertainty
>>> print T
[0.4275, 0.4725]
>>> g = 2*y_0*T**(-2)
>>> g
IntervalMath(8.86873, 11.053)
>>> # Compute with mean values
>>> T = float(T)
>>> y = 1
>>> g = 2*y_0*T**(-2)
>>> print '%.2f' % g
9.88
```

Another formula, the volume $V = \frac{4}{3}\pi R^3$ of a sphere, shows great sensitivity to uncertainties in R :

```
>>> Rm = 6
>>> R = I(Rm*0.9, Rm*1.1)   # 20 % error
>>> V = (4./3)*pi*R**3
>>> V
IntervalMath(659.584, 1204.26)
>>> print V
[659.584, 1204.26]
>>> print float(V)
931.922044761
>>> # Compute with mean values
>>> R = float(R)
>>> V = (4./3)*pi*R**3
>>> print V
904.778684234
```

Here, a 20% uncertainty in R gives almost 60% uncertainty in V , and the mean of the V interval is significantly different from computing the volume with the mean of R .

The complete code of class `IntervalMath` is found in `IntervalMath.py`. Compared to the implementations shown above,

the real implementation in the file employs some ingenious constructions and help methods to save typing and repeating code in the special methods for arithmetic operations.

7.8 Exercises

Exercise 7.1. *Make a function class.*

Make a class `F` that implements the function

$$f(x; a, w) = e^{-ax} \sin(wx).$$

A `value(x)` method computes values of f , while a and w are class attributes. Test the class with the following main program:

```
from math import *
f = F(a=1.0, w=0.1)
print f.value(x=pi)
f.a = 2
print f.value(pi)
```

Name of program file: `F.py`. ◇

Exercise 7.2. *Extend the class from Ch. 7.2.1.*

Add an attribute `transactions` to the `Account` class from Chapter 7.2.1. The new attribute counts the number of transactions done in the `deposit` and `withdraw` methods. The total number of transactions should be printed in the `dump` method. Write a simple test program to demonstrate that `transaction` gets the right value after some calls to `deposit` and `withdraw`. Name of program file: `Account2.py`. ◇

Exercise 7.3. *Make classes for a rectangle and a triangle.*

The purpose of this exercise is to create classes like class `Circle` from Chapter 7.2.3 for representing other geometric figures: a rectangle with width W , height H , and lower left corner (x_0, y_0) ; and a general triangle specified by its three vertices (x_0, y_0) , (x_1, y_1) , and (x_2, y_2) as explained in Exercise 3.9. Provide three methods: `__init__` (to initialize the geometric data), `area`, and `circumference`. Name of program file: `geometric_shapes.py`. ◇

Exercise 7.4. *Make a class for straight lines.*

Make a class `Line` whose constructor takes two points `p1` and `p2` (2-tuples or 2-lists) as input. The line goes through these two points (see function `line` in Chapter 3.1.7 for the relevant formula of the line). A `value(x)` method computes a value on the line at the point x . Here is a demo in an interactive session:

```
>>> from Line import Line
>>> line = Line((0,-1), (2,4))
>>> print line.value(0.5), line.value(0), line.value(1)
0.25 -1.0 1.5
```

Name of program file: Line.py. ◇

Exercise 7.5. *Improve the constructor in Exer. 7.4.*

The constructor in class `Line` in Exercise 7.4 takes two points as arguments. Now we want to have more flexibility in the way we specify a straight line: we can give two points, a point and a slope, or a slope and the line's interception with the y axis. Hint: Let the constructor take two arguments `p1` and `p2` as before, and test with `isinstance` whether the arguments are `float` or `tuple/list` to determine what kind of data the user supplies:

```
if isinstance(p1, (tuple,list)) and isinstance(p2, (float,int)):
    # p1 is a point and p2 is slope
    self.a = p2
    self.b = p1[1] - p2*p1[0]
elif ...
```

Name of program file: Line2.py. ◇

Exercise 7.6. *Make a class for quadratic functions.*

Consider a quadratic function $f(x; a, b, c) = ax^2 + bx + c$. Make a class `Quadratic` for representing f , where a , b , and c are attributes, and the methods are

1. `value` for computing a value of f at a point x ,
2. `table` for writing out a table of x and f values for n x values in the interval $[L, R]$,
3. `roots` for computing the two roots.

Name of program file: Quadratic.py. ◇

Exercise 7.7. *Make a class for linear springs.*

To elongate a spring a distance x , one needs to pull the spring with a force kx . The parameter k is known as the spring constant. The corresponding potential energy in the spring is $\frac{1}{2}kx^2$.

Make a class for springs. Let the constructor store k as a class attribute, and implement the methods `force(x)` and `energy(x)` for evaluating the force and the potential energy, respectively.

The following function prints a table of function values for an arbitrary mathematical function $f(x)$. Demonstrate that you can send the `force` and `energy` methods as the `f` argument to `table`.

```
def table(f, a, b, n, heading=''):
    """Write out f(x) for x in [a,b] with steps h=(b-a)/n."""
    print heading
    h = (b-a)/float(n)
    for i in range(n+1):
        x = a + i*h
        print 'function value = %10.4f at x = %g' % (f(x), x)
```

Name of program file: Spring.py. ◇

Exercise 7.8. *Wrap functions in a class.*

The purpose of this exercise is to offer the code from Exercises 5.14–5.16 as a class. We want to construct a class `Lagrange` which works like this:

```
import numpy as np
# Compute some interpolation points along y=sin(x)
xp = np.linspace(0, pi, 5)
yp = np.sin(xp)

# Lagrange's interpolation polynomial
p_L = LagrangeInterpolation(xp, yp)
x = 1.2
print 'p_L(%g)=g' (x, p_L(x)),
print 'sin(%g)=g' (x, sin(x))
p_L.plot()
```

The `plot` method visualizes $p_L(x)$ for x between the first and last interpolation point (`xp[0]` and `xp[-1]`). The class `LagrangeInterpolation` is easy to make if you import the `Lagrange_poly2` module from Exercise 5.15 and make appropriate calls to the `p_L` and `graph` functions in this module. Also include a `verify` function outside the class and call it as described in Exercise 5.14, but now using the class instead of the `p_L` function directly. Use the class to repeat the investigations that show how the interpolating polynomial may oscillate as the number of interpolation points increases. Name of program file: `Lagrange_poly3.py`.

◇

Exercise 7.9. *Extend the constructor in Exer. 7.8.*

Instead of manually computing the interpolation points, we now want the possibility to pass on some Python function $f(x)$ to the constructor in the class from Exercise 7.9. Typically, we would like to write this code:

```
from numpy import exp, sin, pi

def myfunction(x):
    return exp(-x/2.0)*sin(x)

p_L = LagrangeInterpolation(myfunction, x=[0, pi], n=11)
```

In this particular example, $n = 11$ uniformly distributed x points between 0 and π are computed, and the corresponding y values are obtained by calling `myfunction`. The previous types of calls, `LagrangeInterpolation(xp, yp)`, must still be valid.

The constructor in class `LagrangeInterpolation` must now accept two different set of arguments (`xp, yp` vs. `f, x, n`). You can use the `isinstance(a, t)` function to test if object `a` is of type `t`. Declare the constructor with three arguments `arg1`, `arg2`, and `arg3=None`. Test if `arg1` and `arg2` are arrays (`isinstance(arg1, numpy.ndarray)`),

and in that case, set `xp=arg1` and `yp=arg2`. On the other hand, if `arg1` is a function (`callable(arg1)` is `True`), `arg2` is a list or tuple (`isinstance(arg2, (list,tuple))`), and `arg3` is an integer, set `f=arg1`, `x=arg2`, and `n=arg3`. Name of program file: `Lagrange_poly4.py`. ◇

Exercise 7.10. *Deduce a class implementation.*

Write a class `Hello` that behaves as illustrated in the following session:

```
>>> a = Hello()
>>> print a('students')
Hello, students!
>>> print a
Hello, World!
```

Name of program file: `Hello.py`. ◇

Exercise 7.11. *Use special methods in Exer. 7.1.*

Modify the class from Exercise 7.1 such that the following code works:

```
f = F2(1.0, 0.1)
print f(pi)
f.a = 2
print f(pi)
print f
```

Name of program file: `F2.py`. ◇

Exercise 7.12. *Extend the class from Ch. 7.2.1.*

As alternatives to the `deposit` and `withdraw` methods in class `Account` class from Chapter 7.2.1, we could use `+=` for `deposit` and `-=` for `withdraw`. The special methods `__iadd__` and `__isub__` implement the `+=` and `-=` operators, respectively. For instance, `a -= p` implies a call to `a.__isub__(p)`. One important feature of `__iadd__` and `__isub__` is that they must return `self` to work properly, cf. the documentation of these methods in the Python Language Reference (not to be confused with the Python Library Reference).

Implement the `+=` and `-=` operators, a `__str__` method, and preferably a `__repr__` method. Provide, as always, some code to test that the new methods work as intended. Name of program file: `Account3.py`. ◇

Exercise 7.13. *Implement a class for numerical differentiation.*

A widely used formula for numerical differentiation of a function $f(x)$ takes the form

$$f'(x) \approx \frac{f(x+h) - f(x-h)}{2h}. \quad (7.7)$$

This formula usually gives more accurate derivatives than (7.1) because it applies a centered, rather than a one-sided, difference.

The goal of this exercise is to use the formula (7.7) to automatically differentiate a mathematical function $f(x)$ implemented as a Python function $f(x)$. More precisely, the following code should work:

```
def f(x):
    return 0.25*x**4

df = Central(f) # make function-like object df
# df(x) computes the derivative of f(x) approximately:
for x in (1, 5, 10):
    df_value = df(x) # approx value of derivative of f at point x
    exact = x**3 # exact value of derivative
    print "f'(%d)=%g (error=%E)" % (x, df_value, exact-df_value)
```

Implement class `Central` and test that the code above works. Include an optional argument `h` to the constructor in class `Central` so that one can specify the value of h in the approximation (7.7). Apply class `Central` to produce a table of the derivatives and the associated approximation errors for $f(x) = \ln x$, $x = 10$, and $h = 0.5, 0.1, 10^{-3}, 10^{-5}, 10^{-7}, 10^{-9}, 10^{-11}$. Collect class `Central` and the two applications of the class in the same file, but organize the file as a module so that class `Central` can be imported in other files. Name of program file: `Central.py`. \diamond

Exercise 7.14. *Verify a program.*

Consider this program file for computing a backward difference approximation to the derivative of a function $f(x)$:

```
from math import *

class Backward:
    def __init__(self, f, h=e-9):
        self.f, self.h = f, h
    def __call__(self, x):
        h, f = self.h, self.f
        return (f(x) - f(x-h))/h # finite difference

dsin = Backward(sin)
e = dsin(0) - cos(0); print 'error:', e
dexp = Backward(exp, h=e-7)
e = dexp(0) - exp(0); print 'error:', e
```

The output becomes

```
error: -1.00023355634
error: 371.570909212
```

Is the approximation that bad, or are there bugs in the program? \diamond

Exercise 7.15. *Test methods for numerical differentiation.*

Make a function `table(f, x, hlist, dfdx=None)` for writing out a nicely formatted table of the errors in the numerical derivative of a function $f(x)$ at point x using the two formulas (7.1) and (7.7) and their implementations in classes `Derivative` (from Chapter 7.3.2), and `Central` (from Exercise 7.13). The first column in the table shows a

list of h values (`hlist`), while the two next columns contain the corresponding errors arising from the two numerical approximations of the first derivative. The `dfdx` argument may hold a Python function that returns the exact derivative. Write out an additional column with the exact derivative if `dfdx` is given (i.e., not `None`).

Call `table` for each of the functions x^2 , $\sin^6(\pi x)$, and $\tanh(10x)$, and the x values 0 and 0.25. Can you see from the errors in the tables which of the three approximations that seems to have the overall best performance in these examples? Plot the three functions on $[-1, 1]$ and try to understand the behavior of the various approximations from the plots. Name of program file: `Derivative_comparisons.py`. \diamond

Exercise 7.16. *Modify a class for numerical differentiation.*

Make the two attributes `h` and `f` of class `Derivative` from Chapter 7.3.2 protected as explained in Chapter 7.2.1. That is, prefix `h` and `f` with an underscore to tell users that these attributes should not be accessed directly. Add two methods `get_precision()` and `set_precision(h)` for reading and changing `h`. Apply the modified class to make a table of the approximation error of the derivative of $f(x) = \ln x$ for $x = 1$ and $h = 2^{-k}$, $k = 1, 5, 9, 13, \dots, 45$. Name of program file: `Derivative_protected.py`. \diamond

Exercise 7.17. *Make a class for summation of series.*

Our task in this exercise is to calculate a sum $S(x) = \sum_{k=M}^N f_k(x)$, where $f_k(x)$ is a term in a sequence which is assumed to decrease in absolute value. In class `Sum`, for computing $S(x)$, the constructor requires the following three arguments: $f_k(x)$ as a function `f(k, x)`, M as an `int` object `M`, and N as an `int` object `N`. A `__call__` method computes and returns $S(x)$. The next term in the series, $f_{N+1}(x)$, should be computed and stored as an attribute `first_neglected_term`. Here is an example where we compute $S(x) = \sum_{k=0}^N (-x)^k$:

```
def term(k, x): return (-x)**k

S = Sum(term, M=0, N=100)
x = 0.5
print S(x)
# Print the value of the first neglected term from last S(x) comp.
print S.first_neglected_term
```

Calculate by hand what the output of this test becomes, and use it to verify your implementation of class `Sum`.

Apply class `Sum` to compute the Taylor polynomial approximation for $\sin x$ at $x = \pi, 30\pi$ and $N = 5, 10, 20$. Compute the error and compare with the first neglected term $f_{N+1}(x)$. Present the result in nicely formatted tables. Repeat such calculations for the Taylor polynomial for e^{-x} at $x = 1, 3, 5$ and $N = 5, 10, 20$. Also demonstrate how class `Sum` can be used to calculate the sum (3.1) on page 94 (choose $x = 2, 5, 10$

and $N = 5, 10, 20$). Formulas for the Taylor polynomials can be looked up in Exercise 5.28. Name of program file: `Sum.py`. ◇

Exercise 7.18. *Apply the differentiation class from Ch. 7.3.2.*

Use class `Derivative` from page 362 to calculate the derivative of the function v on page 252 with respect to the parameter n , i.e., $\frac{dv}{dn}$. Choose $\beta/\mu_0 = 50$ and $r/R = 0.5$, and compare the result with the exact derivative. Hint: Make a class similar to `VelocityProfile` on page 350, but provide `r` as a parameter to the constructor, instead of `n`, and let `__call__` take `n` as parameter. Name of program file: `VelocityProfile_deriv.py`. ◇

Exercise 7.19. *Make a class for the Heaviside function.*

Use a class to implement the discontinuous Heaviside function (3.25) from Exercise 3.24 and the smoothed continuous version (3.26) from Exercise 3.25 such that the following code works:

```
H = Heaviside()          # original discontinuous Heaviside function
print H(0.1)
H = Heaviside(eps=0.8)  # smoothed continuous Heaviside function
print H(0.1)
```

Name of program file: `Heaviside_class1.py`. ◇

Exercise 7.20. *Add vectorization to the class in Exer. 7.19.*

Ideally, class `Heaviside` from Exercise 7.19 should allow array arguments:

```
H = Heaviside()          # original discontinuous Heaviside function
x = numpy.linspace(-1, 1, 11)
print H(x)
H = Heaviside(eps=0.8)  # smoothed Heaviside function
print H(x)
```

Use ideas from Chapter 5.5.2 to extend class `Heaviside` such that the code segment above works. Name of program file: `Heaviside_class2.py`.

◇

Exercise 7.21. *Equip the class in Exer. 7.19 with plotting.*

Another desired feature in class `Heaviside` from Exercises 7.19 and 7.20 is support for plotting the function in a given interval between `xmin` and `xmax`:

```
H = Heaviside()
x, y = H.plot(xmin=-4, xmax=4) # H(x-3)
from matplotlib.pyplot import plot
plot(x, y)

H = Heaviside(eps=1)
x, y = H.plot(xmin=-4, xmax=4)
plot(x, y)
```

Techniques from Chapter 5.4.1 must in the first case be used to return arrays `x` and `y` such that the discontinuity is exactly reproduced. In

the continuous (smoothed) case, one needs to compute a sufficiently fine resolution (x) based on the `eps` parameter, e.g., $201/\epsilon$ points in the interval $[-\epsilon, \epsilon]$, with a coarser set of coordinates outside this interval where the smoothed Heaviside function is almost constant, 0 or 1. Extend class `Heaviside` with such a `plot` method. Name of program file: `Heaviside_class3.py`. \diamond

Exercise 7.22. *Make a class for the indicator function.*

Consider the indicator function from Exercise 3.26. Make a class implementation of this function, using the definition (3.28) in terms of Heaviside functions. Allow for an ϵ parameter in the calls to the Heaviside function, as in Exercise 7.19, such that we can easily choose between a discontinuous and a smoothed, continuous version of the indicator function:

```
I = Indicator(a, b)          # indicator function on [a,b]
print I(b+0.1), I((a+b)/2.0)
I = Indicator(0, 2, eps=1)  # smoothed indicator function on [0,2]
print I(0), I(1), I(1.9)
```

Note that if you build on the version of class `Heaviside` in Exercise 7.20, any `Indicator` instance will accept array arguments too. Name of program file: `Indicator.py`. \diamond

Exercise 7.23. *Make a class for piecewise constant functions.*

The purpose of this exercise is to implement a piecewise constant function, as explained in Exercise 3.27, in a Python class. The following code demonstrates the minimum functionality of the class:

```
f = PiecewiseConstant([(0.4, 1), (0.2, 1.5), (0.1, 3)], xmax=4)
print f(1.5), f(1.75), f(4)

x = np.linspace(0, 4, 21)
print f(x)
```

Name of program file: `PiecewiseConstant1.py`. \diamond

Exercise 7.24. *Extend the class in Exer. 7.23 with plot functionality.*

Add a `plot` method to class `PiecewiseConstant` from Exercise 7.23 such that we can easily plot the graph of the piecewise constant function. The `plot` method should return coordinate arrays x and y as explained in Exercise 7.21:

```
f = PiecewiseConstant([(0.4, 1), (0.2, 1.5), (0.1, 3)], xmax=4)
x, y = f.plot()
from matplotlib.pyplot import plot
plot(x, y)
```

Name of program file: `PiecewiseConstant2.py`. \diamond

Exercise 7.25. *Make a module for piecewise constant functions.*

The purpose of this exercise is to pack the extended class `PiecewiseConstant` from Exercise 7.24 in a module, together with

the most advanced versions of the classes `Heaviside` and `Indicator` from Exercises 7.19–7.22. Make a function `_test()` in the module which checks that all the functionality of the classes works as intended. Call `_test()` from the module’s test block. Name of program file: `PiecewiseConstant.py`. ◇

Exercise 7.26. *Use classes for computing inverse functions.*

Appendix A.1.11 describes a method and implementation for computing the inverse function of a given function. The purpose of the present exercise is to improve the implementation in Appendix A.1.11 by introducing classes. This results in software that is more flexible with respect to the way we can specify the function to be inverted.

Implement the `F` and `dFdx` functions from Appendix A.1.11 as classes to avoid relying on global variables for `h`, `xi`, etc. Also introduce a class `InverseFunction` to run the complete algorithm and store the `g` array (from Appendix A.1.11) as an array attribute `values`. Here is a typical use of class `InverseFunction`:

```
>>> from InverseFunction import InverseFunction as I
>>> from scitools.std import *
>>> def f(x):
...     return log(x)
...
>>> x = linspace(1, 5, 101)
>>> f_inv = I(f, x)
>>> plot(x, f(x), x, f_inv.values)
```

Check, in the constructor, that `f` is monotonically increasing or decreasing over the set of coordinates (`x`). Errors may occur in the computations because Newton’s method might divide by zero or diverge. Make sure sensible error messages are reported in those cases.

A `__call__` method in class `InverseFunction` should evaluate the inverse function at an arbitrary point `x`. This is somewhat challenging since we only have the inverse function at discrete points along its curve. With aid of a function `wrap2callable` from `scitools.std` one can turn (x, y) points on a curve, stored in arrays `x` and `y`, into a (piecewise) *continuous* Python function `q(x)` by:

```
q = wrap2callable((x, y))
```

In a sense, the `wrap2callable` call draws lines between the discrete points to form the resulting continuous function. Use `wrap2callable` to make the `__call__` method evaluate the inverse function at any point in the interval from `x[0]` to `x[-1]`. Name of program file: `InverseFunction.py`. ◇

Exercise 7.27. *Vectorize a class for numerical integration.*

Implement a vectorized version of the Trapezoidal rule in class `Integral` from Chapter 7.3.3. Use `sum` to compute the sum in the formula, and allow for either Python’s built-in `sum` function or for the

sum function from `numpy`. Apply the `time` module (see Appendix H.6.1) to measure the relative efficiency of the scalar version versus the two vectorized versions. Name of program file: `Integral_vec.py`. \diamond

Exercise 7.28. *Speed up repeated integral calculations.*

The observant reader may have noticed that our `Integral` class from Chapter 7.3.3 is very inefficient if we want to tabulate or plot a function $F(x) = \int_a^x f(x)$ for several consecutive values of x , say $x_0 < x_1 < \dots < x_n$. Requesting $F(x_k)$ will recompute the integral computed as part of $F(x_{k-1})$, and this is of course waste of computer work. Use the ideas from Appendix A.1.7 to modify the `__call__` method such that if `x` is an array, assumed to contain coordinates of increasing value: $x_0 < x_1 < \dots < x_n$, the method returns an array with $F(x_0), F(x_1), \dots, F(x_n)$. Name of program file: `Integral_eff.py`. \diamond

Exercise 7.29. *Apply a polynomial class.*

The Taylor polynomial of degree N for the exponential function e^x is given by

$$p(x) = \sum_{k=0}^N \frac{x^k}{k!}.$$

Make a program that (i) imports class `Polynomial` from page 369, (ii) reads x and a series of N values from the command line, (iii) creates a `Polynomial` instance representing the Taylor polynomial, and (iv) prints the values of $p(x)$ for the given N values as well as the exact value e^x . Try the program out with $x = 0.5, 3, 10$ and $N = 2, 5, 10, 15, 25$. Name of program file: `Polynomial_exp.py`. \diamond

Exercise 7.30. *Find a bug in a class for polynomials.*

Go through this alternative implementation of class `Polynomial` from page 369 and explain each line in detail:

```
class Polynomial:
    def __init__(self, coefficients):
        self.coeff = coefficients

    def __call__(self, x):
        return sum([c*x**i for i, c in enumerate(self.coeff)])

    def __add__(self, other):
        maxlength = max(len(self), len(other))
        # Extend both lists with zeros to this maxlength
        self.coeff += [0]*(maxlength - len(self.coeff))
        other.coeff += [0]*(maxlength - len(other.coeff))
        result_coeff = self.coeff
        for i in range(maxlength):
            result_coeff[i] += other.coeff[i]
        return Polynomial(result_coeff)
```

The `enumerate` function, used in the `__call__` method, enables us to iterate over a list `somelist` with both list indices and list elements: `for index, element in enumerate(somelist)`. Write the code above in a

file, and demonstrate that adding two polynomials does not work. Find the bug and correct it. Name of program file: `Polynomial_error.py`. ◇

Exercise 7.31. *Implement subtraction of polynomials.*

Implement the special method `__sub__` in class `Polynomial` from page 369. Name of program file: `Polynomial_sub.py`. ◇

Exercise 7.32. *Represent a polynomial by a NumPy array.*

Introduce a Numerical Python array for `self.coeff` in class `Polynomial` from page 369. Go through the class code and run the statements in the `_test` method in the `Polynomial.py` file to locate which statements that need to be modified because `self.coeff` is an array and not a list. Name of program file: `Polynomial_array1.py`. ◇

Exercise 7.33. *Vectorize a class for polynomials.*

Introducing an array instead of a list in class `Polynomial`, as suggested in Exercise 7.32, does not enhance the implementation. A real enhancement arise when the code is vectorized, i.e., when loops are replaced by operations on whole arrays.

First, vectorize the `__add__` method by adding the common parts of the coefficients arrays and then appending the rest of the longest array to the result (appending an array `a` to an array `b` is done by `concatenate(a, b)`).

Second, vectorize the `__call__` method by observing that evaluation of a polynomial, $\sum_{i=0}^{n-1} c_i x^i$, can be computed as the inner product of two arrays: (c_0, \dots, c_{n-1}) and $(x^0, x^1, \dots, x^{n-1})$. The latter array can be computed by `x**p`, where `p` is an array with powers $0, 1, \dots, n-1$.

Third, the `differentiate` method can be vectorized by the statements

```
n = len(self.coeff)
self.coeff[:-1] = linspace(1, n-1, n-1)*self.coeff[1:]
self.coeff = self.coeff[:-1]
```

Show by hand calculations in a case where `n` is 3 that the vectorized statements produce the same result as the original `differentiate` method.

The `__mul__` method is more challenging to vectorize so you may leave this unaltered. Check that the vectorized versions of `__add__`, `__call__`, and `differentiate` work by comparing with the scalar code from Exercise 7.32 or the original, list-based `Polynomial` class. Name of program file: `Polynomial_array2.py`. ◇

Exercise 7.34. *Use a dict to hold polynomial coefficients; add.*

Use a dictionary for `self.coeff` in class `Polynomial` from page 369. The advantage with a dictionary is that only the nonzero coefficients need to be stored. Let `self.coeff[k]` hold the coefficient of the x^k term. Implement a constructor and the `__add__` method. Exemplify

the implementation by adding $x - 3x^{100}$ and $x^{20} - x + 4x^{100}$. Name of program file: `Polynomial_dict1.py`. \diamond

Exercise 7.35. *Use a dict to hold polynomial coefficients; mul.*

Extend the class in Exercise 7.34 with a `__mul__` method. First, study the algorithm in Chapter 7.3.7 for the `__mul__` method when the coefficients are stored in lists. Then modify the algorithm to work with dictionaries. Implement the algorithm and exemplify it by multiplying $x - 3x^{100}$ and $x^{20} - x + 4x^{100}$. Name of program file: `Polynomial_dict2.py`. \diamond

Exercise 7.36. *Extend class Vec2D to work with lists/tuples.*

The `Vec2D` class from Chapter 7.4 supports addition and subtraction, but only addition and subtraction of two `Vec2D` objects. Sometimes we would like to add or subtract a point that is represented by a list or a tuple:

```
u = Vec2D(-2, 4)
v = u + (1, 1.5)
w = [-3, 2] - v
```

That is, a list or a tuple must be allowed in the right or left operand. Use ideas from Chapters 7.5.3 and 7.5.4 to implement this extension. Name of program file: `Vec2D_lists.py`. \diamond

Exercise 7.37. *Extend class Vec2D to 3D vectors.*

Extend the implementation of class `Vec2D` from Chapter 7.4 to a class `Vec3D` for vectors in three-dimensional space. Add a method `cross` for computing the cross product of two 3D vectors. Name of program file: `Vec3D.py`. \diamond

Exercise 7.38. *Use NumPy arrays in class Vec2D.*

The internal code in class `Vec2D` from Chapter 7.4 can be valid for vectors in any space dimension if we represent the vector as a NumPy array in the class instead of separate variables `x` and `y` for the vector components. Make a new class `Vec` where you apply NumPy functionality in the methods. The constructor should be able to treat all the following ways of initializing a vector:

```
a = array([1, -1, 4], float) # numpy array
v = Vec(a)
v = Vec([1, -1, 4])         # list
v = Vec((1, -1, 4))        # tuple
v = Vec(1, -1)             # coordinates
```

We will provide some helpful advice. In the constructor, use variable number of arguments as described in Appendix H.5. All arguments are then available as a tuple, and if there is only one element in the tuple, it should be an array, list, or tuple you can send through `asarray` to get a NumPy array. If there are many arguments, these are coordinates, and

the tuple of arguments can be transformed by `array` to a NumPy array. Assume in all operations that the involved vectors have equal dimension (typically that `other` has the same dimension as `self`). Recall to return `Vec` objects from all arithmetic operations, not NumPy arrays, because the next operation with the vector will then not take place in `Vec` but in NumPy. If `self.v` is the attribute holding the vector as a NumPy array, the addition operator will typically be implemented as

```
class Vec:
    ...
    def __add__(self, other):
        return Vec(self.v + other.v)
```

Name of program file: `Vec.py`. ◇

Exercise 7.39. *Use classes in the program from Ch. 6.7.2.*

Modify the `files/students.py` program described in Chapter 6.7.2 by making the values of the `data` dictionary instances of class `Student`. This class contains a student's name and a list of the courses. Each course is represented by an instance of class `Course`. This class contains the course name, the semester, the credit points, and the grade. Make `__str__` and/or `__repr__` write out the contents of the objects. Name of program file: `Student_Course.py`. ◇

Exercise 7.40. *Use a class in Exer. A.25.*

The purpose of this exercise is to make the program from Exercise A.25 on page 591 more flexible by creating a class that runs and archives all the experiments. Here is a sketch of the class:

```
class GrowthLogistic:
    def __init__(self, show_plot_on_screen=False):
        self.experiments = []
        self.show_plot_on_screen = show_plot_on_screen
        self.remove_plot_files()

    def run_one(self, y0, q, N):
        """Run one experiment."""
        # Compute y[n] in a loop...
        plotfile = 'tmp_y0_%g_q_%g_N_%d.png' % (y0, q, N)
        self.experiments.append({'y0': y0, 'q': q, 'N': N,
                                'mean': mean(y[20:]),
                                'y': y, 'plotfile': plotfile})

        # Make plot...

    def run_many(self, y0_list, q_list, N):
        """Run many experiments."""
        for q in q_list:
            for y0 in y0_list:
                self.run_one(y0, q, N)

    def remove_plot_files(self):
        """Remove plot files with names tmp_y0*.png."""
        import os, glob
        for plotfile in glob.glob('tmp_y0*.png'):
            os.remove(plotfile)

    def report(self, filename='tmp.html'):
```

```

"""
Generate an HTML report with plots of all
experiments generated so far.
"""
# Open file and write HTML header...
for e in self.experiments:
    html.write('<p>\n' % e['plotfile'])
# Write HTML footer and close file...

```

Each time the `run_one` method is called, data about the current experiment is stored in the `experiments` list. Note that `experiments` contains a list of dictionaries. When desired, we can call the `report` method to collect all the plots made so far in an HTML report. A typical use of the class goes as follows:

```

N = 50
g = GrowthLogistic()
g.run_many(y0_list=[0.01, 0.3],
           q_list=[0.1, 1, 1.5, 1.8] + [2, 2.5, 3], N=N)
g.run_one(y0=0.01, q=3, N=1000)
g.report()

```

Make a complete implementation of class `GrowthLogistic` and test it with the small program above. The program file should be constructed as a module. Name of program file: `growth_logistic5.py`. \diamond

Exercise 7.41. *Apply the class from Exer. 7.40 interactively.*

Class `GrowthLogistic` from Exercise 7.40 is very well suited for interactive exploration. Here is a possible sample session for illustration:

```

>>> from growth_logistic5 import GrowthLogistic
>>> g = GrowthLogistic(show_plot_on_screen=True)
>>> q = 3
>>> g.run_one(0.01, q, 100)
>>> y = g.experiments[-1]['y']
>>> max(y)
1.3326056469620293
>>> min(y)
0.0029091569028512065

```

Extend this session with an investigation of the oscillations in the solution y_n . For this purpose, make a function for computing the local maximum values y_n and the corresponding indices where these local maximum values occur. We can say that y_i is a local maximum value if

$$y_{i-1} < y_i > y_{i+1}.$$

Plot the sequence of local maximum values in a new plot. If I_0, I_1, I_2, \dots constitute the set of increasing indices corresponding to the local maximum values, we can define the periods of the oscillations as $I_1 - I_0$, $I_2 - I_1$, and so forth. Plot the length of the periods in a separate plot. Repeat this investigation for $q = 2.5$. Name of program file: `GrowthLogistic_interactive.py`. \diamond

Exercise 7.42. Find local and global extrema of a function.

Extreme points of a function $f(x)$ are normally found by solving $f'(x) = 0$. A much simpler method is to evaluate $f(x)$ for a set of discrete points in the interval $[a, b]$ and look for local minima and maxima among these points. We work with n equally spaced points $a = x_0 < x_1 < \dots < x_{n-1} = b$, $x_i = a + ih$, $h = (b - a)/(n - 1)$.

1. First we find all local extreme points in the interior of the domain. Local minima are recognized by

$$f(x_{i-1}) > f(x_i) < f(x_{i+1}), \quad i = 1, \dots, n - 2.$$

Similarly, at a local maximum point x_i we have

$$f(x_{i-1}) < f(x_i) > f(x_{i+1}), \quad i = 1, \dots, n - 2.$$

We let P_{\min} be the set of x values for local minima and F_{\min} the set of the corresponding $f(x)$ values at these minimum points. Two sets P_{\max} and F_{\max} are defined correspondingly, containing the maximum points and their values.

2. The boundary points $x = a$ and $x = b$ are for algorithmic simplicity also defined as local extreme points: $x = a$ is a local minimum if $f(a) < f(x_1)$, and a local maximum otherwise. Similarly, $x = b$ is a local minimum if $f(b) < f(x_{n-2})$, and a local maximum otherwise. The end points a and b and the corresponding function values must be added to the sets P_{\min} , P_{\max} , F_{\min} , F_{\max} .
3. The global maximum point is defined as the x value corresponding to the maximum value in F_{\max} . The global minimum point is the x value corresponding to the minimum value in F_{\min} .

Make a class `MinMax` with the following functionality:

- The constructor takes $f(x)$, a , b , and n as arguments, and calls a method `_find_extrema` to compute the local and global extreme points.
- The method `_find_extrema` implements the algorithm above for finding local and global extreme points, and stores the sets P_{\min} , P_{\max} , F_{\min} , F_{\max} as list attributes in the (`self`) instance.
- The method `get_global_minimum` returns the global minimum point (x).
- The method `get_global_maximum` returns the global maximum point (x).
- The method `get_all_minima` returns a list or array of all minimum points.
- The method `get_all_maxima` returns a list or array of all maximum points.
- The method `__str__` returns a string where all the min/max points are listed, plus the global extreme points.

Here is a sample code using class `MinMax`:

```
def f(x):
    return x**2*exp(-0.2*x)*sin(2*pi*x)

m = MinMax(f, 0, 4, 5001)
print m
```

The output becomes

```
All minima: 0.8056, 1.7736, 2.7632, 3.7584, 0
All maxima: 0.3616, 1.284, 2.2672, 3.2608, 4
Global minimum: 3.7584
Global maximum: 3.2608
```

Make sure that the program also works for functions without local extrema, e.g., linear functions $f(x) = px + q$. Name of program file: `minmaxf.py`. \diamond

Exercise 7.43. *Improve the accuracy in Exer. 7.42.*

The algorithm in Exercise 7.42 finds local extreme points x_i , but we know is that the true extreme point is in the interval (x_{i-1}, x_{i+1}) . A more accurate algorithm may take this interval as a starting point and run a Bisection method (see Chapter 4.6.2) to find the extreme point \bar{x} such that $f'(\bar{x}) = 0$. In class `MinMax`, add a method `_refine_extrema`, which goes through all the interior local minima and maxima and solves $f'(\bar{x}) = 0$. Compute $f'(x)$ using the `Derivative` class (Chapter 7.3.2 with $h \ll x_{i+1} - x_{i-1}$). Name of program file: `minmaxf2.py`. \diamond

Exercise 7.44. *Find the optimal production for a company.*

The company PROD produces two different products, P_1 and P_2 , based on three different raw materials, M_1 , M_2 and M_3 . The following table shows how much of each raw material M_i that is required to produce a *single unit* of each product P_j :

	P_1	P_2
M_1	2	1
M_2	5	3
M_3	0	4

For instance, to produce one unit of P_2 one needs 1 unit of M_1 , 3 units of M_2 and 4 units of M_3 . Furthermore, PROD has available 100, 80 and 150 units of material M_1 , M_2 and M_3 respectively (for the time period considered). The revenue per produced unit of product P_1 is 150 NOK, and for one unit of P_2 it is 175 NOK. On the other hand the raw materials M_1 , M_2 and M_3 cost 10, 17 and 25 NOK per unit, respectively. The question is: How much should PROD produce of each product? We here assume that PROD wants to maximize its net revenue (which is revenue minus costs).

- (a) Let x and y be the number of units produced of product P_1 and P_2 , respectively. Explain why the total revenue $f(x, y)$ is given by

$$f(x, y) = 150x - (10 \cdot 2 + 17 \cdot 5)x + 175y - (10 \cdot 1 + 17 \cdot 3 + 25 \cdot 4)y$$

and simplify this expression. The function $f(x, y)$ is *linear* in x and y (check that you know what linearity means).

- (b) Explain why PROD's problem may be stated mathematically as follows:

$$\begin{aligned} & \text{maximize } f(x, y) \\ & \text{subject to} \\ & \quad 2x + y \leq 100 \\ & \quad 5x + 3y \leq 80 \\ & \quad 4y \leq 150 \\ & \quad x \geq 0, y \geq 0. \end{aligned} \tag{7.8}$$

This is an example of a *linear optimization problem*.

- (c) The production (x, y) may be considered as a point in the plane. Illustrate geometrically the set T of all such points that satisfy the constraints in model (7.8). Every point in this set is called a *feasible point*. (Hint: For every inequality determine first the straight line obtained by replacing the inequality by equality. Then, find the points satisfying the inequality (a half-plane), and finally, intersect these half-planes.)
- (d) Make a program `optimization1.py` for drawing the straight lines defined by the inequalities. Each line can be written as $ax + by = c$. Let the program read each line from the command line as a list of the a , b , and c values. In the present case the command-line arguments will be

```
'[2,1,100]' '[5,3,80]' '[0,4,150]' '[1,0,0]' '[0,1,0]'
```

(Hint: Perform an `eval` on the elements of `sys.argv[1:]` to get a , b , and c for each line as a list in the program.)

- (e) Let α be a positive number and consider the *level set* of the function f , defined as the set

$$L_\alpha = \{(x, y) \in T : f(x, y) = \alpha\}.$$

This set consists of all feasible points having the same net revenue α . Extend the program with two new command-line arguments holding p and q for a function $f(x, y) = px + qy$. Use this information to compute the level set lines $y = \alpha/q - px/q$, and plot the level set lines for some different values of α (use the α value in the legend for each line).

- (f) Use what you saw in (e) to solve the problem (7.8) geometrically. (Hint: How large can you choose α such that L_α is nonempty?) This solution is called an *optimal solution*.

Name of program file: `optimization1.py`.

◇

Exercise 7.45. *Extend the program from Exer. 7.44.*

Assume that we have other values on the revenues and costs than the actual numbers in Exercise 7.44. Explain why (7.8), with these new parameter values, still has an optimal solution lying in a corner point of T . Extend the program from Exercise 7.44 to calculate all the corner points of a region T in the plane determined by the linear inequalities like those listed in Exercise 7.44. Moreover, the program shall compute the maximum of a given linear function $f(x, y) = px + qy$ over T by calculating the function values in the corner points and finding the smallest function value. Name of program file: `optimization2.py`.

The example in Exercises 7.44 and 7.45 is from *linear optimization*, also called *linear programming*. Most universities and business schools have a good course in this important area of applied mathematics. \diamond

Random numbers have many applications in science and computer programming, especially when there are significant uncertainties in a phenomenon of interest. The purpose of this chapter is to look at some practical problems involving random numbers and learn how to program with such numbers. We shall make several games and also look into how random numbers can be used in physics. You need to be familiar with Chapters 1–5 in order to study the present chapter, but a few examples and exercises will require familiarity with the class concept from Chapter 7.

The key idea in computer simulations with random numbers is first to formulate an algorithmic description of the phenomenon we want to study. This description frequently maps directly onto a quite simple and short Python program, where we use random numbers to mimic the uncertain features of the phenomenon. The program needs to perform a large number of repeated calculations, and the final answers are “only” approximate, but the accuracy can usually be made good enough for practical purposes. Most programs related to the present chapter produce their results within a few seconds. In cases where the execution times become large, we can vectorize the code. Vectorized computations with random numbers is definitely the most demanding topic in this chapter, but is not mandatory for seeing the power of mathematical modeling via random numbers.

All files associated with the examples in this chapter are found in the folder `src/random`.

8.1 Drawing Random Numbers

Python has a module `random` for generating random numbers. The function call `random.random()` generates a random number in the half open interval¹ $[0, 1)$. We can try it out:

```
>>> import random
>>> random.random()
0.81550546885338104
>>> random.random()
0.44913326809029852
>>> random.random()
0.88320653116367454
```

All computations of random numbers are based on deterministic algorithms (see Exercise 8.20 for an example), so the sequence of numbers cannot be truly random. However, the sequence of numbers appears to lack any pattern, and we can therefore view the numbers as random².

8.1.1 The Seed

Every time we import `random`, the subsequent sequence of `random.random()` calls will yield different numbers. For debugging purposes it is useful to get the same sequence of random numbers every time we run the program. This functionality is obtained by setting a *seed* before we start generating numbers. With a given value of the seed, one and only one sequence of numbers is generated. The seed is an integer and set by the `random.seed` function:

```
>>> random.seed(121)
```

Let us generate two series of random numbers at once, using a list comprehension and a format with two decimals only:

```
>>> random.seed(2)
>>> ['%.2f' % random.random() for i in range(7)]
['0.96', '0.95', '0.06', '0.08', '0.84', '0.74', '0.67']
>>> ['%.2f' % random.random() for i in range(7)]
['0.31', '0.61', '0.61', '0.58', '0.16', '0.43', '0.39']
```

If we set the seed to 2 again, the sequence of numbers is regenerated:

```
>>> random.seed(2)
>>> ['%.2f' % random.random() for i in range(7)]
['0.96', '0.95', '0.06', '0.08', '0.84', '0.74', '0.67']
```

If we do not give a seed, the `random` module sets a seed based on the current time. That is, the seed will be different each time we run

¹ In the half open interval $[0, 1)$ the lower limit is included, but the upper limit is not.

² What it means to view the numbers as random has fortunately a firm mathematical foundation, so don't let the fact that random numbers are deterministic stop you from using them.

the program and consequently the sequence of random numbers will also be different from run to run. This is what we want in most applications. However, we recommend to always set a seed during program development to simplify debugging and verification.

8.1.2 Uniformly Distributed Random Numbers

The numbers generated by `random.random()` tend to be equally distributed between 0 and 1, which means that there is no part of the interval $[0, 1)$ with more random numbers than other parts. We say that the distribution of random numbers in this case is *uniform*. The function `random.uniform(a,b)` generates uniform random numbers in the half open interval $[a, b)$, where the user can specify a and b . With the following program (in file `uniform_numbers0.py`) we may generate lots of random numbers in the interval $[-1, 1)$ and visualize how they are distributed:

```
import random
random.seed(42)
N = 500 # no of samples
x = range(N)
y = [random.uniform(-1,1) for i in x]

import scitools.std as st
st.plot(x, y, '+', axis=[0,N-1,-1.2,1.2])
```

Figure 8.1 shows the values of these 500 numbers, and as seen, the numbers appear to be random and uniformly distributed between -1 and 1 .

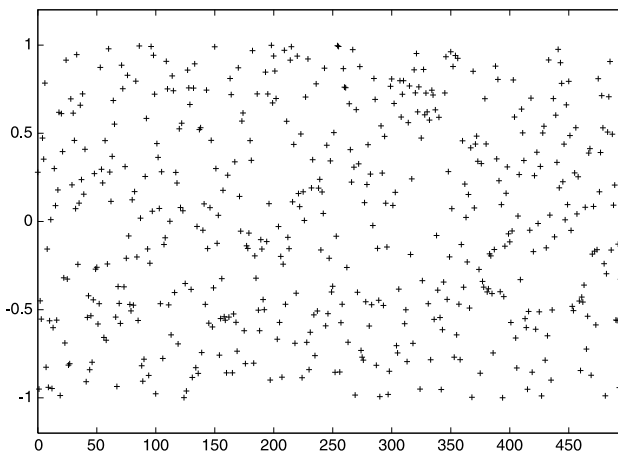

Fig. 8.1 The values of 500 random numbers drawn from the uniform distribution on $[-1, 1)$.

8.1.3 Visualizing the Distribution

It is of interest to see how N random numbers in an interval $[a, b]$ are distributed throughout the interval, especially as $N \rightarrow \infty$. For example, when drawing numbers from the uniform distribution, we expect that no parts of the interval get more numbers than others. To visualize the distribution, we can divide the interval into subintervals and display how many numbers there are in each subinterval.

Let us formulate this method more precisely. We divide the interval $[a, b]$ into n equally sized subintervals, each of length $h = (b - a)/n$. These subintervals are called *bins*. We can then draw N random numbers by calling `random.random()` N times. Let $\hat{H}(i)$ be the number of random numbers that fall in bin no. i , $[a + ih, a + (i + 1)h]$, $i = 0, \dots, n - 1$. If N is small, the value of $\hat{H}(i)$ can be quite different for the different bins, but as N grows, we expect that $\hat{H}(i)$ varies little with i .

Ideally, we would be interested in how the random numbers are distributed as $N \rightarrow \infty$ and $n \rightarrow \infty$. One major disadvantage is that $\hat{H}(i)$ increases as N increases, and it decreases with n . The quantity $\hat{H}(i)/N$, called the frequency count, will reach a finite limit as $N \rightarrow \infty$. However, $\hat{H}(i)/N$ will be smaller and smaller as we increase the number of bins. The quantity $H(i) = \hat{H}(i)/(Nh)$ reaches a finite limit as $N, n \rightarrow \infty$. The probability that a random number lies inside subinterval no. i is then $\hat{H}(i)/N = H(i)h$.

We can visualize $H(i)$ as a bar diagram (see Figure 8.2), called a *normalized histogram*. We can also define a piecewise constant function $p(x)$ from $H(i)$: $p(x) = H(i)$ for $x \in [a + ih, a + (i + 1)h]$, $i = 0, \dots, n - 1$. As $n, N \rightarrow \infty$, $p(x)$ approaches the probability density function of the distribution in question. For example, `random.uniform(a,b)` draws numbers from the uniform distribution on $[a, b]$, and the probability density function is constant, equal to $1/(b - a)$. As we increase n and N , we therefore expect $p(x)$ to approach the constant $1/(b - a)$.

The function `compute_histogram` from `scitools.std` returns two arrays `x` and `y` such that `plot(x,y)` plots the piecewise constant function $p(x)$. The plot is hence the histogram of the set of random samples. The program below exemplifies the usage:

```
from scitools.std import plot, compute_histogram
import random
samples = [random.random() for i in range(100000)]
x, y = compute_histogram(samples, nbins=20)
plot(x, y)
```

Figure 8.2 shows two plots corresponding to N taken as 10^3 and 10^6 . For small N , we see that some intervals get more random numbers than others, but as N grows, the distribution of the random numbers becomes more and more equal among the intervals. In the limit $N \rightarrow \infty$, $p(x) \rightarrow 1$, which is illustrated by the plot.

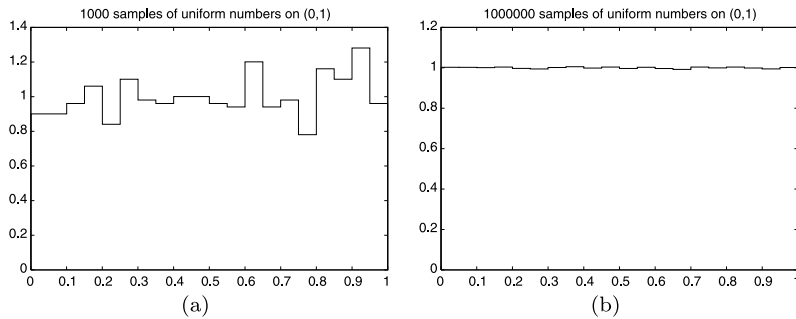

Fig. 8.2 The histogram of uniformly distributed random numbers in 20 bins.

8.1.4 Vectorized Drawing of Random Numbers

There is a `random` module in the Numerical Python package which can be used to efficiently draw a possibly large array of random numbers:

```
import numpy as np
r = np.random.random()           # one number between 0 and 1
r = np.random.random(size=10000) # array with 10000 numbers
r = np.random.uniform(-1, 10)    # one number between -1 and 10
r = np.random.uniform(-1, 10, size=10000) # array
```

There are thus two `random` modules to be aware of: one in the standard Python library and one in `numpy`. For drawing uniformly distributed numbers, the two `random` modules have the same interface, except that the functions from `numpy`'s `random` module has an extra `size` parameter. Both modules also have a `seed` function for fixing the seed.

Vectorized drawing of random numbers using `numpy`'s `random` module is efficient because all the numbers are drawn “at once” in fast C code. You can measure the efficiency gain with the `time.clock()` function as explained on page 450 and in Appendix H.6.1.

Warning. It is easy to do an `import random` followed by a `from scitools.std import *` or a `from numpy import *` without realizing that the latter two import statements import a name `random` that overwrites the same name that was imported in `import random`. The result is that the effective `random` module becomes the one from `numpy`. A possible solution to this problem is to introduce a different name for Python's `random` module, say

```
import random as random_number
```

Another solution is to do `import numpy as np` and work explicitly with `np.random`.

8.1.5 Computing the Mean and Standard Deviation

You probably know the formula for the mean or average of a set of n numbers x_0, x_1, \dots, x_{n-1} :

$$x_m = \frac{1}{n} \sum_{j=0}^{n-1} x_j. \quad (8.1)$$

The amount of spreading of the x_i values around the mean x_m can be measured by the *variance*³,

$$x_v = \frac{1}{n} \sum_{j=0}^{n-1} (x_j - x_m)^2. \quad (8.2)$$

A variant of this formula reads

$$x_v = \frac{1}{n} \left(\sum_{j=0}^{n-1} x_j^2 \right) - x_m^2. \quad (8.3)$$

The good thing with this latter formula is that one can, as a statistical experiment progresses and n increases, record the sums

$$s_m = \sum_{j=0}^{q-1} x_j, \quad s_v = \sum_{j=0}^{q-1} x_j^2 \quad (8.4)$$

and then, when desired, efficiently compute the most recent estimate on the mean value and the variance after q samples by

$$x_m = s_m/q, \quad x_v = s_v/q - s_m^2/q^2. \quad (8.5)$$

The *standard deviation*

$$x_s = \sqrt{x_v} \quad (8.6)$$

is often used as an alternative to the variance, because the standard deviation has the same unit as the measurement itself. A common way to express an uncertain quantity x , based on a data set x_0, \dots, x_{n-1} , from simulations or physical measurements, is $x_m \pm x_s$. This means that x has an uncertainty of one standard deviation x_s to either side of the mean value x_m . With probability theory and statistics one can provide many other, more precise measures of the uncertainty, but that is the topic of a different course.

Below is an example where we draw numbers from the uniform distribution on $[-1, 1)$ and compute the evolution of the mean and standard deviation 10 times during the experiment, using the formulas (8.1) and (8.3)–(8.6):

³ Textbooks in statistics teach you that it is more appropriate to divide by $n - 1$ instead of n , but we are not going to worry about that fact in this book.

```

import sys
N = int(sys.argv[1])
import random
from math import sqrt
sm = 0; sv = 0
for q in range(1, N+1):
    x = random.uniform(-1, 1)
    sm += x
    sv += x**2

    # Write out mean and st.dev. 10 times in this loop
    if q % (N/10) == 0:
        xm = sm/q
        xs = sqrt(sv/q - xm**2)
        print '%10d mean: %12.5e stdev: %12.5e' % (q, xm, xs)

```

The `if` test applies the `mod` function, see Chapter 3.4.2, for checking if a number can be divided by another without any remainder. The particular `if` test here is true when `i` equals 0, `N/10`, `2*N/10`, \dots , `N`, i.e., 10 times during the execution of the loop. The program is available in the file `mean_stdev_uniform1.py`. A run with $N = 10^6$ gives the output

```

100000 mean:  1.86276e-03 stdev:  5.77101e-01
200000 mean:  8.60276e-04 stdev:  5.77779e-01
300000 mean:  7.71621e-04 stdev:  5.77753e-01
400000 mean:  6.38626e-04 stdev:  5.77944e-01
500000 mean: -1.19830e-04 stdev:  5.77752e-01
600000 mean:  4.36091e-05 stdev:  5.77809e-01
700000 mean: -1.45486e-04 stdev:  5.77623e-01
800000 mean:  5.18499e-05 stdev:  5.77633e-01
900000 mean:  3.85897e-05 stdev:  5.77574e-01
1000000 mean: -1.44821e-05 stdev:  5.77616e-01

```

We see that the mean is getting smaller and approaching zero as expected since we generate numbers between -1 and 1 . The theoretical value of the standard deviation, as $N \rightarrow \infty$, equals $\sqrt{1/3} \approx 0.57735$.

We have also made a corresponding vectorized version of the code above using `numpy`'s `random` module and the ready-made functions `mean`, `var`, and `std` for computing the mean, variance, and standard deviation (respectively) of an array of numbers:

```

import sys
N = int(sys.argv[1])
import numpy as np
x = np.random.uniform(-1, 1, size=N)
xm = np.mean(x)
xv = np.var(x)
xs = np.std(x)
print '%10d mean: %12.5e stdev: %12.5e' % (N, xm, xs)

```

This program can be found in the file `mean_stdev_uniform2.py`.

8.1.6 The Gaussian or Normal Distribution

In some applications we want random numbers to cluster around a specific value m . This means that it is more probable to generate a number close to m than far away from m . A widely used distribution

with this qualitative property is the Gaussian or normal distribution⁴. The normal distribution has two parameters: the mean value m and the standard deviation s . The latter measures the width of the distribution, in the sense that a small s makes it less likely to draw a number far from the mean value, and a large s makes more likely to draw a number far from the mean value.

Single random numbers from the normal distribution can be generated by

```
import random
r = random.normalvariate(m, s)
```

while efficient generation of an array of length N is enabled by

```
import numpy as np
r = np.random.normal(m, s, size=N)
r = np.random.randn(N) # mean=0, std.dev.=1
```

The following program draws N random numbers from the normal distribution, computes the mean and standard deviation, and plots the histogram:

```
import sys
N = int(sys.argv[1])
m = float(sys.argv[2])
s = float(sys.argv[3])

import numpy as np
np.random.seed(12)
samples = np.random.normal(m, s, N)
print np.mean(samples), np.std(samples)

import scitools.std as st
x, y = st.compute_histogram(samples, 20, piecewise_constant=True)
st.plot(x, y, hardcopy='tmp.eps',
        title = '%d samples of Gaussian/normal numbers on (0,1)' % N)
```

The corresponding program file is `normal_numbers1.py`, which gives a mean of -0.00253 and a standard deviation of 0.99970 when run with N as 1 million, m as 0, and s equal to 1. Figure 8.3 shows that the random numbers cluster around the mean $m = 0$ in a histogram. This normalized histogram will, as N goes to infinity, approach a bell-shaped function, known as the normal distribution probability density function, given in (1.6) on page 45.

8.2 Drawing Integers

Suppose we want to draw a random integer among the values 1, 2, 3, and 4, and that each of the four values is equally probable. One

⁴ For example, the blood pressure among adults of one gender has values that follow a normal distribution.

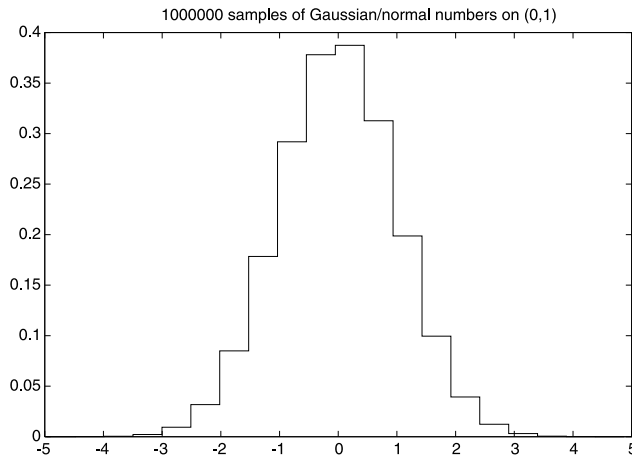

Fig. 8.3 Normalized histogram of 1 million random numbers drawn from the normal distribution.

possibility is to draw real numbers from the uniform distribution on, e.g., $[0, 1)$ and divide this interval into four equal subintervals:

```
import random
r = random.random()
if 0 <= r < 0.25:
    r = 1
elif 0.25 <= r < 0.5:
    r = 2
elif 0.5 <= r < 0.75:
    r = 3
else:
    r = 4
```

Nevertheless, the need for drawing uniformly distributed integers occurs quite frequently, so there are special functions for returning random integers in a specified interval $[a, b]$.

8.2.1 Random Integer Functions

Python's `random` module has a built-in function `randint(a, b)` for drawing an integer in $[a, b]$, i.e., the return value is among the numbers $a, a+1, \dots, b-1, b$.

```
import random
r = random.randint(a, b)
```

The `numpy.random.randint(a, b, N)` function has a similar functionality for vectorized drawing of an array of length N of random integers in $[a, b)$. The upper limit b is not among the drawn numbers, so if we want to draw from $a, a+1, \dots, b-1, b$, we must write

```
import numpy as np
r = np.random.randint(a, b+1, N)
```

Another function, `random_integers(a, b, N)`, also in `numpy.random`, includes the upper limit `b` in the possible set of random integers:

```
r = np.random.random_integers(a, b, N)
```

8.2.2 Example: Throwing a Die

We can make a program that lets the computer throw a die `N` times and count how many times we get six eyes:

```
import random
import sys
N = int(sys.argv[1]) # perform N experiments
M = 0 # no of times we get 6 eyes
for i in xrange(N):
    outcome = random.randint(1, 6)
    if outcome == 6:
        M += 1
print 'Got six %d times out of %d' % (M, N)
```

We use `xrange` instead of `range` because the former is more efficient when `N` is large. The vectorized version of this code can be expressed as follows:

```
import numpy as np
import sys
N = int(sys.argv[1])
eyes = np.random.randint(1, 7, N)
success = eyes == 6 # True/False array
M = np.sum(success) # treats True as 1, False as 0
print 'Got six %d times out of %d' % (M, N)
```

The `eyes == 6` construction results in an array with `True` or `False` values, and `sum` applied to this array treats `True` as 1 and `False` as 0 (the integer equivalents to the boolean values), so the sum is the number of elements in `eyes` that equals 6. A very important point here for computational efficiency is to use `np.sum` and not the standard `sum` function that is available in standard Python. With `np.sum` function, the vectorized version runs about 50 times faster than the scalar version. With Python's standard `sum` function, the vectorized versions is in fact slower than the scalar version (!).

The two small programs above are found in the files `roll_die.py` and `roll_die_vec.py`, respectively. You can try the programs and see how much faster the vectorized version is (`N` probably needs to be of size at least 10^6 to see any noticeable differences for practical purposes).

8.2.3 Drawing a Random Element from a List

Given a list `a`, the statement

```
re = random.choice(a)
```

picks out an element of `a` at random, and `re` refers to this element. The shown call to `random.choice` is the same as

```
re = a[random.randint(0, len(a)-1)]
```

There is also a function `shuffle` that performs a random permutation of the list elements:

```
random.shuffle(a)
```

Picking now `a[0]`, for instance, has the same effect as `random.choice` on the original, unshuffled list. Note that `shuffle` changes the list given as argument.

The `numpy.random` module has also a `shuffle` function with the same functionality.

A small session illustrates the various methods for picking a random element from a list:

```
>>> awards = ['car', 'computer', 'ball', 'pen']
>>> import random
>>> random.choice(awards)
'car'
>>> awards[random.randint(0, len(awards)-1)]
'pen'
>>> random.shuffle(awards)
>>> awards[0]
'computer'
```

8.2.4 Example: Drawing Cards from a Deck

The following function creates a deck of cards, where each card is represented as a string, and the deck is a list of such strings:

```
def make_deck():
    ranks = ['A', '2', '3', '4', '5', '6', '7',
            '8', '9', '10', 'J', 'Q', 'K']
    suits = ['C', 'D', 'H', 'S']
    deck = []
    for s in suits:
        for r in ranks:
            deck.append(s + r)
    random.shuffle(deck)
    return deck
```

Here, 'A' means an ace, 'J' represents a jack, 'Q' represents a queen, 'K' represents a king, 'C' stands for clubs, 'D' stands for diamonds, 'H' means hearts, and 'S' means spades. The computation of the list `deck` can alternatively (and more compactly) be done by a one-line list comprehension:

```
deck = [s+r for s in suits for r in ranks]
```

We can draw a card at random by

```
deck = make_deck()
card = deck[0]
del deck[0]
# or better:
card = deck.pop(0) # return and remove element with index 0
```

Drawing a hand of n cards from a shuffled deck is accomplished by

```
def deal_hand(n, deck):
    hand = [deck[i] for i in range(n)]
    del deck[:n]
    return hand, deck
```

Note that we must return `deck` to the calling code since this list is changed. Also note that the n first cards of the deck are random cards if the deck is shuffled (and any deck made by `make_deck` is shuffled).

The following function deals cards to a set of players:

```
def deal(cards_per_hand, no_of_players):
    deck = make_deck()
    hands = []
    for i in range(no_of_players):
        hand, deck = deal_hand(cards_per_hand, deck)
        hands.append(hand)
    return hands
```

```
players = deal(5, 4)
import pprint; pprint.pprint(players)
```

The `players` list may look like

```
[['D4', 'CQ', 'H10', 'DK', 'CK'],
 ['D7', 'D6', 'SJ', 'S4', 'C5'],
 ['C3', 'DQ', 'S3', 'C9', 'DJ'],
 ['H6', 'H9', 'C6', 'D5', 'S6']]
```

The next step is to analyze a hand. Of particular interest is the number of pairs, three of a kind, four of a kind, etc. That is, how many combinations there are of $n_of_a_kind$ cards of the same rank (e.g., $n_of_a_kind=2$ finds the number of pairs):

```
def same_rank(hand, n_of_a_kind):
    ranks = [card[1:] for card in hand]
    counter = 0
    already_counted = []
    for rank in ranks:
        if rank not in already_counted and \
            ranks.count(rank) == n_of_a_kind:
            counter += 1
            already_counted.append(rank)
    return counter
```

Note how convenient the `count` method in list objects is for counting how many copies there are of one element in the list.

Another analysis of the hand is to count how many cards there are of each suit. A dictionary with the suit as key and the number of cards with that suit as value, seems appropriate to return. We pay attention only to suits that occur more than once:

```
def same_suit(hand):
    suits = [card[0] for card in hand]
    counter = {} # counter[suit] = how many cards of suit
    for suit in suits:
        count = suits.count(suit)
        if count > 1:
            counter[suit] = count
    return counter
```

For a set of players we can now analyze their hands:

```
for hand in players:
    print ""\
The hand %s
    has %d pairs, %s 3-of-a-kind and
    %s cards of the same suit."" % \
    ('', '.join(hand), same_rank(hand, 2),
    same_rank(hand, 3),
    '+' .join([str(s) for s in same_suit(hand).values()])))
```

The values we feed into the printf string undergo some massage: we join the card values with comma and put a plus in between the counts of cards with the same suit. (The join function requires a string argument. That is why the integer counters of cards with the same suit, returned from `same_suit`, must be converted to strings.) The output of the for loop becomes

```
The hand D4, CQ, H10, DK, CK
    has 1 pairs, 0 3-of-a-kind and
    2+2 cards of the same suit.
The hand D7, D6, SJ, S4, C5
    has 0 pairs, 0 3-of-a-kind and
    2+2 cards of the same suit.
The hand C3, DQ, S3, C9, DJ
    has 1 pairs, 0 3-of-a-kind and
    2+2 cards of the same suit.
The hand H6, H9, C6, D5, S6
    has 0 pairs, 1 3-of-a-kind and
    2 cards of the same suit.
```

The file `cards.py` contains the functions `make_deck`, `hand`, `same_rank`, `same_suit`, and the test snippets above. With the `cards.py` file one can start to implement real card games.

8.2.5 Example: Class Implementation of a Deck

To work with a deck of cards with the code from the previous section one needs to shuffle a global variable `deck` in and out of functions. A set of functions that update global variables (like `deck`) is a primary candidate for a class: The global variables are stored as attributes and the functions become class methods. This means that the code from the previous section is better implemented as a class. We introduce class

Deck with a list of cards, `deck`, as attribute, and methods for dealing one or several hands and for putting back a card:

```
class Deck:
    def __init__(self):
        ranks = ['A', '2', '3', '4', '5', '6', '7',
                 '8', '9', '10', 'J', 'Q', 'K']
        suits = ['C', 'D', 'H', 'S']
        self.deck = [s+r for s in suits for r in ranks]
        random.shuffle(self.deck)

    def hand(self, n=1):
        """Deal n cards. Return hand as list."""
        hand = [self.deck[i] for i in range(n)] # pick cards
        del self.deck[:n] # remove cards
        return hand

    def deal(self, cards_per_hand, no_of_players):
        """Deal no_of_players hands. Return list of lists."""
        return [self.hand(cards_per_hand) \
                for i in range(no_of_players)]

    def putback(self, card):
        """Put back a card under the rest."""
        self.deck.append(card)

    def __str__(self):
        return str(self.deck)
```

This class is found in the module file `Deck.py`. Dealing a hand of five cards to `p` players is coded as

```
from Deck import Deck
deck = Deck()
print deck
players = deck.deal(5, 4)
```

Here, `players` become a nested list as shown in Chapter 8.2.4.

One can go a step further and make more classes for assisting card games. For example, a card has so far been represented by a plain string, but we may well put that string in a class `Card`:

```
class Card:
    """Representation of a card as a string (suit+rank)."""
    def __init__(self, suit, rank):
        self.card = suit + str(rank)

    def __str__(self): return self.card
    def __repr__(self): return str(self)
```

Note that `str(self)` is equivalent to `self.__str__()`.

A `Hand` contains a set of `Card` instances and is another natural abstraction, and hence a candidate for a class:

```
class Hand:
    """Representation of a hand as a list of Card objects."""
    def __init__(self, list_of_cards):
        self.hand = list_of_cards

    def __str__(self): return str(self.hand)
    def __repr__(self): return str(self)
```

With the aid of classes `Card` and `Hand`, class `Deck` can be reimplemented as

```
class Deck:
    """Representation of a deck as a list of Card objects."""

    def __init__(self):
        ranks = ['A', '2', '3', '4', '5', '6', '7',
                '8', '9', '10', 'J', 'Q', 'K']
        suits = ['C', 'D', 'H', 'S']
        self.deck = [Card(s,r) for s in suits for r in ranks]
        random.shuffle(self.deck)

    def hand(self, n=1):
        """Deal n cards. Return hand as a Hand object."""
        hand = Hand([self.deck[i] for i in range(n)])
        del self.deck[:n]      # remove cards
        return hand

    def deal(self, cards_per_hand, no_of_players):
        """Deal no_of_players hands. Return list of Hand obj."""
        return [self.hand(cards_per_hand) \
                for i in range(no_of_players)]

    def putback(self, card):
        """Put back a card under the rest."""
        self.deck.append(card)

    def __str__(self):
        return str(self.deck)

    def __repr__(self):
        return str(self)

    def __len__(self):
        return len(self.deck)
```

The module file `Deck2.py` contains this implementation. The usage of the two `Deck` classes is the same,

```
from Deck2 import Deck
deck = Deck()
players = deck.deal(5, 4)
```

with the exception that `players` in the last case holds a list of `Hand` instances, and each `Hand` instance holds a list of `Card` instances.

We stated in Chapter 7.3.9 that the `__repr__` method should return a string such that one can recreate the object from this string by the aid of `eval`. However, we did not follow this rule in the implementation of classes `Card`, `Hand`, and `Deck`. Why? The reason is that we want to print a `Deck` instance. Python's `print` or `pprint` on a list applies `repr(e)` to print an element `e` in the list. Therefore, if we had implemented

```
class Card:
    ...
    def __repr__(self):
        return "Card('%s', %s)" % (self.card[0], self.card[1:])

class Hand:
    ...
    def __repr__(self): return 'Hand(%s)' % repr(self.hand)
```

a plain printing of the deck list of `Hand` instances would lead to output like

```
[Hand([Card('C', '10'), Card('C', '4'), Card('H', 'K'), ...]),
      Hand([Card('D', '7'), Card('C', '5'), ..., Card('D', '9')])]
```

This output is harder to read than

```
[C10, C4, HK, DQ, HQ],
[SA, S8, H3, H10, C2],
[HJ, C7, S2, CQ, DK],
[D7, C5, DJ, S3, D9]
```

That is why we let `__repr__` in classes `Card` and `Hand` return the same “pretty print” string as `__str__`, obtained by returning `str(self)`.

8.3 Computing Probabilities

With the mathematical rules from *probability theory* one may compute the probability that a certain event happens, say the probability that you get one black ball when drawing three balls from a hat with four black balls, six white balls, and three green balls. Unfortunately, theoretical calculations of probabilities may soon become hard or impossible if the problem is slightly changed. There is a simple “numerical way” of computing probabilities that is generally applicable to problems with uncertainty. The principal ideas of this approximate technique is explained below, followed by three examples of increasing complexity.

8.3.1 Principles of Monte Carlo Simulation

Assume that we perform N experiments where the outcome of each experiment is random. Suppose that some event takes place M times in these N experiments. An estimate of the probability of the event is then M/N . The estimate becomes more accurate as N is increased, and the exact probability is assumed to be reached in the limit as $N \rightarrow \infty$. (Note that in this limit, $M \rightarrow \infty$ too, so for rare events, where M may be small in a program, one must increase N such that M is sufficiently large for M/N to become a good approximation to the probability.)

Programs that run a large number of experiments and record the outcome of events are often called *simulation programs*⁵. The mathematical technique of letting the computer perform lots of experiments based on drawing random numbers is commonly called *Monte Carlo simulation*. This technique has proven to be extremely useful throughout science and industry in problems where there is uncertain or ran-

⁵ This term is also applied for programs that solve equations arising in mathematical models in general, but it is particularly common to use the term when random numbers are used to estimate probabilities.

dom behavior is involved⁶. For example, in finance the stock market has a random variation that must be taken into account when trying to optimize investments. In offshore engineering, environmental loads from wind, currents, and waves show random behavior. In nuclear and particle physics, random behavior is fundamental according to quantum mechanics and statistical physics. Many probabilistic problems can be calculated exactly by mathematics from probability theory, but very often Monte Carlo simulation is the only way to solve statistical problems. Chapters 8.3.2–8.3.5 applies examples to explain the essence of Monte Carlo simulation in problems with inherent uncertainty. However, also deterministic problems, such as integration of functions, can be computed by Monte Carlo simulation (see Chapter 8.5).

It appears that Monte Carlo simulation programmed in pure Python is a computationally feasible approach, even on small laptops, in all the forthcoming examples. Significant speed-up can be achieved by vectorizing the code, which is explained in detail for many of the examples. However, large-scale Monte Carlo simulations and other heavy computations run slowly in pure Python, and the core of the computations should be moved to a compiled language such as C. Appendix G presents a Monte Carlo application that is implemented in pure Python, in vectorized `numpy` Python, in the extended (and very closely related) Cython language, as well as in pure C code. Various ways of combining Python with C are also illustrated.

8.3.2 Example: Throwing Dice

You throw two dice, one black and one green. What is the probability that the number of eyes on the black die is larger than the number of eyes on the green die?

Straightforward Solution. We can simulate N throws of two dice in a program. For each throw we see if the event is successful, and if so, increase M by one:

```
import sys
N = int(sys.argv[1])           # no of experiments

import random
M = 0                          # no of successful events
for i in range(N):
    black = random.randint(1, 6) # throw black
    green = random.randint(1, 6) # throw brown
    if black > green:           # success?
        M += 1
p = float(M)/N
print 'probability:', p
```

This program is named `black_gt_green.py`.

⁶ “As far as the laws of mathematics refer to reality, they are not certain, as far as they are certain, they do not refer to reality.” –Albert Einstein, physicist, 1879–1955.

Vectorization. Although the `black_gt_green.py` program runs $N = 10^6$ in a few seconds, Monte Carlo simulation programs can quickly require quite some simulation time so speeding up the algorithm by vectorization is often desired. Let us vectorize the code shown above. The idea is to draw all the random numbers ($2N$) at once. We make an array of random numbers between 1 and 6 with 2 rows and N columns. The first column can be taken as the number of eyes on the black die in all the experiments, while the second column are the corresponding eyes on the green die:

```
r = np.random.random_integers(1, 6, size=(2, N))
black = r[0,:] # eyes for all throws with black
green = r[1,:] # eyes for all throws with green
```

The condition `black > green` results in an array of length N of boolean values: `True` when the element in `black` is greater than the corresponding element in `green`, and `False` if not. The number of `True` elements in the boolean array `black > green` is then M . This number can be computed by summing up all the boolean values. In arithmetic operations, `True` is 1 and `False` is 0, so the sum equals M . Fast summation of arrays requires `np.sum` and not Python's standard `sum` function. The code goes like

```
success = black > green # success[i] is true if black[i]>green[i]
M = np.sum(success) # sum up all successes
p = float(M)/N
print 'probability:', p
```

The code, found in the file `black_gt_green_vec.py`, runs over 10 times faster than the corresponding scalar code in `black_gt_green.py`.

Exact Solution. In this simple example we can quite easily compute the exact solution. To this end, we set up all the outcomes of the experiment, i.e., all the possible combinations of eyes on two dice:

```
combinations = [(black, green)
                 for black in range(1, 7)
                 for green in range(1, 7)]
```

Then we count how many of the `(black, green)` pairs that have the property `black > green`:

```
success = [black > green for black, green in combinations]
M = sum(success)
```

It turns out that M is 15, giving a probability $15/36 \approx 0.41667$ since there are 36 combinations in total. Running the Monte Carlo simulations with $N = 10^6$ typically gives probabilities in $[0.416, 0.417]$.

A Game. Suppose a game is constructed such that you have to pay 1 euro to throw the two dice. You win 2 euros if there are more eyes on

the black than on the green die. Should you play this game? We can easily simulate the game directly (file `black_gt_green_game.py`):

```
import sys
N = int(sys.argv[1])          # no of experiments

import random
start_capital = 10
money = start_capital
for i in range(N):
    money -= 1                # pay for the game
    black = random.randint(1, 6) # throw black
    green = random.randint(1, 6) # throw brown
    if black > green:         # success?
        money += 2           # get award

net_profit_total = money - start_capital
net_profit_per_game = net_profit_total/float(N)
print 'Net profit per game in the long run:', net_profit_per_game
```

Experimenting with a few N shows that the net profit per game is always negative. That is, you should *not* play this game.

A vectorized version is beneficial of efficiency reasons (the corresponding file is `black_gt_green_game_vec.py`):

```
import sys
N = int(sys.argv[1])          # no of experiments

import numpy as np
r = np.random.random_integers(1, 6, size=(2, N))

money = 10 - N                # capital after N throws
black = r[0,:]                # eyes for all throws with black
green = r[1,:]                # eyes for all throws with green
success = black > green       # success[i] is true if black[i]>green[i]
M = np.sum(success)           # sum up all successes
money += 2*M                  # add all awards for winning
print 'Net profit per game in the long run:', (money-10)/float(N)
```

Decide If a Game Is Fair. Suppose the cost of playing a game once is q and that the award for winning is r . The net income in a winning game is $r - q$. Winning M out of N games means that the cost is Nq and the income is Mr , making a net profit $s = Mr - Nq$. Now $p = M/N$ is the probability of winning the game so $s = (pr - q)N$. A fair game means that we neither win nor lose in the long run: $s = 0$, which implies that $r = q/p$. That is, given the cost q and the probability p of winning, the award paid for winning the game must be $r = q/p$ in a fair game.

When somebody comes up with a game you can use Monte Carlo simulation to estimate p and then conclude that you should not play the game of $r < q/p$. The example above has $p = 15/36$ (exact) and $q = 1$, so $r = 2.4$ makes a fair game.

The reasoning above is based on common sense and an intuitive interpretation of probability. More precise reasoning from probability theory will introduce the game as an experiment with two outcomes, either you win with probability p and or lose with probability $1 - p$.

The expected payment is then the sum of the probabilities times the corresponding net income for each event: $-q(1-p) + (r-q)p$ (recall that the net income in a winning game is $r-q$). A fair game has zero expected payment, which leads to $r = q/p$.

8.3.3 Example: Drawing Balls from a Hat

Suppose there are 12 balls in a hat: four black, four red, and four blue. We want to make a program that draws three balls at random from the hat. It is natural to represent the collection of balls as a list. Each list element can be an integer 1, 2, or 3, since we have three different types of balls, but it would be easier to work with the program if the balls could have a color instead of an integer number. This is easily accomplished by defining color names:

```
colors = 'black', 'red', 'blue' # (tuple of strings)
hat = []
for color in colors:
    for i in range(4):
        hat.append(color)
```

Drawing a ball at random is performed by

```
import random
color = random.choice(hat)
print color
```

Drawing n balls without replacing the drawn balls requires us to remove an element from the hat when it is drawn. There are three ways to implement the procedure: (i) we perform a `hat.remove(color)`, (ii) we draw a random index with `randint` from the set of legal indices in the `hat` list, and then we do a `del hat[index]` to remove the element, or (iii) we can compress the code in (ii) to `hat.pop(index)`.

```
def draw_ball(hat):
    color = random.choice(hat)
    hat.remove(color)
    return color, hat

def draw_ball(hat):
    index = random.randint(0, len(hat)-1)
    color = hat[index]
    del hat[index]
    return color, hat

def draw_ball(hat):
    index = random.randint(0, len(hat)-1)
    color = hat.pop(index)
    return color, hat

# Draw n balls from the hat
balls = []
for i in range(n):
    color, hat = draw_ball(hat)
    balls.append(color)
print 'Got the balls', balls
```

We can extend the experiment above and ask the question: What is the probability of drawing two or more black balls from a hat with 12 balls, four black, four red, and four blue? To this end, we perform N experiments, count how many times M we get two or more black balls, and estimate the probability as M/N . Each experiment consists of making the hat list, drawing a number of balls, and counting how many black balls we got. The latter task is easy with the count method in list objects: `hat.count('black')` counts how many elements with value 'black' we have in the list `hat`. A complete program for this task is listed below. The program appears in the file `balls_in_hat.py`.

```
import random

def draw_ball(hat):
    """Draw a ball using list index."""
    index = random.randint(0, len(hat)-1)
    color = hat.pop(index)
    return color, hat

def draw_ball(hat):
    """Draw a ball using list index."""
    index = random.randint(0, len(hat)-1)
    color = hat[index]
    del hat[index]
    return color, hat

def draw_ball(hat):
    """Draw a ball using list element."""
    color = random.choice(hat)
    hat.remove(color)
    return color, hat

def new_hat():
    colors = 'black', 'red', 'blue' # (tuple of strings)
    hat = []
    for color in colors:
        for i in range(4):
            hat.append(color)
    return hat

n = int(raw_input('How many balls are to be drawn? '))
N = int(raw_input('How many experiments? '))

# Run experiments
M = 0 # no of successes
for e in range(N):
    hat = new_hat()
    balls = [] # the n balls we draw
    for i in range(n):
        color, hat = draw_ball(hat)
        balls.append(color)
    if balls.count('black') >= 2: # at least two black balls?
        M += 1
print 'Probability:', float(M)/N
```

Running the program with $n = 5$ (drawing 5 balls each time) and $N = 4000$ gives a probability of 0.57. Drawing only 2 balls at a time reduces the probability to about 0.09.

One can with the aid of probability theory derive theoretical expressions for such probabilities, but it is much simpler to let the computer

perform a large number of experiments to estimate an approximate probability.

A class version of the code in this section is better than the code presented, because we avoid shuffling the `hat` variable in and out of functions. Exercise 8.21 asks you to design and implement a class `Hat`.

8.3.4 Random Mutations of Genes

A Simple Mutation Model. A fundamental principle of biological evolution is that DNA undergoes mutation. Since DNA can be represented as a string consisting of the letters A, C, G, and T, as explained in Chapter 3.3, mutation of DNA is easily modeled by replacing the letter in a randomly chosen position of the DNA by a randomly chosen letter from the alphabet A, C, G, and T. A function for replacing the letter in a randomly selected position (index) by a random letter among A, C, G, and T is most straightforwardly implemented by converting the DNA string to a list of letters, since changing a character in a Python string is impossible without constructing a new string. However, an element in a list can be changed in-place:

```
import random

def mutate_v1(dna):
    dna_list = list(dna)
    mutation_site = random.randint(0, len(dna_list) - 1)
    dna_list[mutation_site] = random.choice(list('ATCG'))
    return ''.join(dna_list)
```

Using the functions `get_base_frequencies_v2` and `format_frequencies` from Chapter 6.6.3, we can easily mutate a gene a number of times and see how the frequencies of the bases A, C, G, and T change:

```
dna = 'ACGGAGATTTCGGTATGCAT'
print 'Starting DNA:', dna
print format_frequencies(get_base_frequencies_v2(dna))

nmutations = 10000
for i in range(nmutations):
    dna = mutate_v1(dna)

print 'DNA after %d mutations:' % nmutations, dna
print format_frequencies(get_base_frequencies_v2(dna))
```

Here is the output from a run:

```
Starting DNA: ACGGAGATTTCGGTATGCAT
A: 0.25, C: 0.15, T: 0.30, G: 0.30
DNA after 10000 mutations: AACCAATCCGACGAGGAGTG
A: 0.35, C: 0.25, T: 0.10, G: 0.30
```

Vectorized Version. The efficiency of the `mutate_v1` function with its surrounding loop can be significantly increased up by performing all

the mutations at once using numpy arrays. This speed-up is of interest for long dna strings and many mutations. The idea is to draw all the mutation sites at once, and also all the new bases at these sites at once. The `np.random` module provides functions for drawing several random numbers at a time, but only integers and real numbers can be drawn, not characters from the alphabet A, C, G, and T. We therefore have to simulate these four characters by the numbers (say) 0, 1, 2, and 3. Afterwards we can translate the integers to letters by some clever vectorized indexing.

Drawing N mutation sites is a matter of drawing N random integers among the legal indices:

```
import numpy as np
mutation_sites = np.random.random_integers(0, len(dna)-1, size=N)
```

Drawing N bases, represented as the integers 0–3, is similarly done by

```
new_bases_i = np.random.random_integers(0, 3, N)
```

Converting say the integers 1 to the base symbol C is done by picking out the indices (in a boolean array) where `new_bases_i` equals 1, and inserting the character 'C' in a companion array of characters:

```
new_bases_c = np.zeros(N, dtype='c')
indices = new_bases_i == 1
new_bases_c[indices] = 'C'
```

We must do this integer-to-letter conversion for all four integers/letters. Thereafter, `new_bases_c` must be inserted in `dna` for all the indices corresponding to the randomly drawn mutation sites,

```
dna[mutation_sites] = new_bases_c
```

The final step is to convert the numpy array of characters `dna` back to a standard string by first converting `dna` to a list and then joining the list elements: `''.join(dna.tolist())`.

The complete vectorized functions can now be expressed as follows:

```
import numpy as np
# Use integers in random numpy arrays and map these
# to characters according to
i2c = {0: 'A', 1: 'C', 2: 'G', 3: 'T'}

def mutate_v2(dna, N):
    dna = np.array(dna, dtype='c') # array of characters
    mutation_sites = np.random.random_integers(
        0, len(dna) - 1, size=N)
    # Must draw bases as integers
    new_bases_i = np.random.random_integers(0, 3, size=N)
    # Translate integers to characters
    new_bases_c = np.zeros(N, dtype='c')
    for i in i2c:
        new_bases_c[new_bases_i == i] = i2c[i]
    dna[mutation_sites] = new_bases_c
    return ''.join(dna.tolist())
```

It is of interest to time `mutate_v2` versus `mutate_v1`. For this purpose we need a long test string. A straightforward generation of random letters is

```
def generate_string_v1(N, alphabet='ACGT'):
    return ''.join([random.choice(alphabet) for i in xrange(N)])
```

A vectorized version of this function can also be made, using the ideas explored above for the `mutate_v2` function:

```
def generate_string_v2(N, alphabet='ACGT'):
    # Draw random integers 0,1,2,3 to represent bases
    dna_i = np.random.random_integers(0, 3, N)
    # Translate integers to characters
    dna = np.zeros(N, dtype='c')
    for i in xrange(N):
        dna[dna_i == i] = alphabet[i]
    return ''.join(dna.tolist())
```

The `time_mutate` function in the file `mutate.py` performs timing of the generation of test strings and the mutations. To generate a DNA string of length 100,000 the vectorized function is about 8 times faster. When performing 10,000 mutations on this string, the vectorized version is almost 3000 times faster! These numbers stay approximately the same also for larger strings and more mutations. Hence, this case study on vectorization is a striking example on the fact that a straightforward and convenient function like `mutate_v1` might occasionally be very slow for large-scale computations.

A Markov Chain Mutation Model. The observed rate at which mutations occur at a given position in the genome is not independent of the type of nucleotide (base) at that position, as was assumed in the previous simple mutation model. We should therefore take into account that the rate of transition depends on the base.

There are a number of reasons why the observed mutation rates vary between different nucleotides. One reason is that there are different mechanisms generating transitions from one base to another. Another reason is that there are extensive repair processes in living cells, and the efficiency of this repair mechanism varies for different nucleotides.

Mutation of nucleotides may be modeled using distinct probabilities for the transitions from each nucleotide to every other nucleotide. For example, the probability of replacing A by C may be prescribed as (say) 0.2. In total we need 4×4 probabilities since each nucleotide can transform into itself (no change) or three others. The sum of all four transition probabilities for a given nucleotide must sum up to one. Such statistical evolution, based on probabilities for transitioning from one state to another, is known as a Markov process or Markov chain.

First we need to set up the probability matrix, i.e., the 4×4 table of probabilities where each row corresponds to the transition of A, C,

G, or T into A, C, G, or T. Say the probability transition from A to A is 0.2, from A to C is 0.1, from A to G is 0.3, and from A to T is 0.4.

Rather than just prescribing some arbitrary transition probabilities for test purposes, we can use random numbers for these probabilities. To this end, we generate three random numbers to divide the interval $[0, 1]$ into four intervals corresponding to the four possible transitions. The lengths of the intervals give the transition probabilities, and their sum is ensured to be 1. The interval limits, 0, 1, and three random numbers must be sorted in ascending order to form the intervals. We use the function `random.random()` to generate random numbers in $[0, 1)$:

```
slice_points = sorted(
    [0] + [random.random() for i in range(3)] + [1])
transition_probabilities = [slice_points[i+1] - slice_points[i]
    for i in range(4)]
```

The transition probabilities are handy to have available as a dictionary:

```
markov_chain['A'] = {'A': ..., 'C': ..., 'G': ..., 'T': ...}
```

which can be computed by

```
markov_chain['A'] = {base: p for base, p in
    zip('ACGT', transition_probabilities)}
```

To select a transition, we need to draw a random letter (A, C, G, or T) according to the probabilities `markov_chain[b]` where `b` is the base at the current position. Actually, this is a very common operation, namely drawing a random value from a *discrete probability distribution* (`markov_chain[b]`). The natural approach is therefore write a general function for drawing from any discrete probability distribution given as a dictionary:

```
def draw(discrete_probdist):
    """
    Draw random value from discrete probability distribution
    represented as a dict: P(x=value) = discrete_probdist[value].
    """
    # Method:
    # http://en.wikipedia.org/wiki/Pseudo-random_number_sampling
    limit = 0
    r = random.random()
    for value in discrete_probdist:
        limit += discrete_probdist[value]
        if r < limit:
            return value
```

Basically, the algorithm divides $[0, 1]$ into intervals of lengths equal to the probabilities of the various outcomes and checks which interval is hit by a random variable in $[0, 1]$. The corresponding value is the random choice.

A complete function creating all the transition probabilities and storing them in a dictionary of dictionaries takes the form

```

def create_markov_chain():
    markov_chain = {}
    for from_base in 'ATGC':
        # Generate random transition probabilities by dividing
        # [0,1] into four intervals of random length
        slice_points = sorted(
            [0] + [random.random() for i in range(3)] + [1])
        transition_probabilities = \
            [slice_points[i+1] - slice_points[i] for i in range(4)]
        markov_chain[from_base] = {base: p for base, p
                                   in zip('ATGC', transition_probabilities)}
    return markov_chain

mc = create_markov_chain()
print mc
print mc['A']['T'] # probability of transition from A to T

```

It is natural to develop a function for checking that the generated probabilities are consistent. The transition from a particular base into one of the four bases happens with probability 1, which means that the probabilities in a row must sum up to 1:

```

def test_transition_probabilities(markov_chain):
    for from_base in 'ATGC':
        s = sum(markov_chain[from_base][to_base]
                for to_base in 'ATGC')
        if abs(s - 1) > 1E-15:
            raise ValueError('Wrong sum: %s for "%s"' % \
                              (s, from_base))

```

Another test is to check that draw actually draws random values in accordance with the underlying probabilities. To this end, we draw a large number of values, N , count the frequencies of the various values, divide by N and compare the empirical normalized frequencies with the probabilities:

```

def test_draw_approx(discrete_probdist, N=1000000):
    """
    See if draw results in frequencies approx equal to
    the probability distribution.
    """
    frequencies = {value: 0 for value in discrete_probdist}
    for i in range(N):
        value = draw(discrete_probdist)
        frequencies[value] += 1
    for value in frequencies:
        frequencies[value] /= float(N)
    print ', '.join(['%s: %.4f (exact %.4f)' % \
                    (v, frequencies[v], discrete_probdist[v])
                    for v in frequencies])

```

This test is only approximate, but does bring evidence to the correctness of the implementation of the draw function.

A vectorized version of draw can also be made. We refer to the source code file `mutate.py` for details (the function is relatively complicated).

Now we have all the tools needed to run the Markov chain of transitions for a randomly selected position in a DNA sequence:

```
def mutate_via_markov_chain(dna, markov_chain):
    dna_list = list(dna)
    mutation_site = random.randint(0, len(dna_list) - 1)
    from_base = dna[mutation_site]
    to_base = draw(markov_chain[from_base])
    dna_list[mutation_site] = to_base
    return ''.join(dna_list)
```

Exercise 8.51 suggests some efficiency enhancements of simulating mutations via these functions.

Here is a simulation of mutations using the method based on Markov chains:

```
dna = 'TTACGGAGATTTCGGTATGCAT'
print 'Starting DNA:', dna
print format_frequencies(get_base_frequencies_v2(dna))

mc = create_markov_chain()
import pprint
print 'Transition probabilities:\n', pprint.pformat(mc)
nmutations = 10000
for i in range(nmutations):
    dna = mutate_via_markov_chain(dna, mc)

print 'DNA after %d mutations (Markov chain):' % nmutations, dna
print format_frequencies(get_base_frequencies_v2(dna))
```

The output will differ each time the program is run unless `random.seed(i)` is called in the beginning of the program for some integer `i`. This call makes the sequence of random numbers the same every time the program is run and is very useful for debugging. An example on the output may look like

```
Starting DNA: TTACGGAGATTTCGGTATGCAT
A: 0.23, C: 0.14, T: 0.36, G: 0.27
Transition probabilities:
{'A': {'A': 0.4288890546751146,
      'C': 0.4219086988655296,
      'G': 0.00668870644455688,
      'T': 0.14251354001479888},
 'C': {'A': 0.24999667668640035,
      'C': 0.04718309085408834,
      'G': 0.6250440975238185,
      'T': 0.0777761349356928},
 'G': {'A': 0.16022955651881965,
      'C': 0.34652746609882423,
      'G': 0.1328031742612512,
      'T': 0.3604398031211049},
 'T': {'A': 0.20609823213950174,
      'C': 0.17641112746655452,
      'G': 0.010267621176125452,
      'T': 0.6072230192178183}}
```

DNA after 10000 mutations (Markov chain): GGTTAAGTCAGCTATGATTCT
A: 0.23, C: 0.14, T: 0.41, G: 0.23

The various functions performing mutations are located in the file `mutate.py`.

8.3.5 Example: Policies for Limiting Population Growth

China has for many years officially allowed only one child per couple. However, the success of the policy has been somewhat limited. One

challenge is the current over-representation of males in the population (families have favored sons to live up). An alternative policy is to allow each couple to continue getting children until they get a son. We can simulate both policies and see how a population will develop under the “one child” and the “one son” policies. Since we expect to work with a large population over several generations, we aim at vectorized code at once.

Suppose we have a collection of n individuals, called `parents`, consisting of males and females randomly drawn such that a certain portion (`male_portion`) constitutes males. The `parents` array holds integer values, 1 for male and 2 for females. We can introduce constants, `MALE=1` and `FEMALE=2`, to make the code easier to read. Our task is to see how the `parents` array develop from one generation to the next under the two policies. Let us first show how to draw the random integer array `parents` where there is a probability `male_portion` of getting the value `MALE`:

```
import numpy as np
r = np.random.random(n)
parents = np.zeros(n, int)
MALE = 1; FEMALE = 2
parents[r < male_portion] = MALE
parents[r >= male_portion] = FEMALE
```

The number of potential couples is the minimum of males and females. However, only a fraction (`fertility`) of the couples will actually get a child. Under the perfect “one child” policy, these couples can have one child each:

```
males = len(parents[parents==MALE])
females = len(parents) - males
couples = min(males, females)
n = int(fertility*couples) # couples that get a child

# The next generation, one child per couple
r = random.random(n)
children = np.zeros(n, int)
children[r < male_portion] = MALE
children[r >= male_portion] = FEMALE
```

The code for generating a new population will be needed in every generation. Therefore, it is natural to collect the last statements in a separate function such that we can repeat the statements when needed.

```
def get_children(n, male_portion, fertility):
    n = int(fertility*n)
    r = random.random(n)
    children = zeros(n, int)
    children[r < male_portion] = MALE
    children[r >= male_portion] = FEMALE
    return children
```

Under the “one son” policy, the families can continue getting a new child until they get the first son:

```
# First try
children = get_children(couples, male_portion, fertility)

# Continue with getting a new child for each daughter
daughters = children[children == FEMALE]
while len(daughters) > 0:
    new_children = get_children(len(daughters),
                               male_portion, fertility)
    children = np.concatenate((children, new_children))
    daughters = new_children[new_children == FEMALE]
```

The program `birth_policy.py` organizes the code segments above for the two policies into a function `advance_generation`, which we can call repeatedly to see the evolution of the population.

```
def advance_generation(parents, policy='one child',
                      male_portion=0.5, fertility=1.0):
    males = len(parents[parents==MALE])
    females = len(parents) - males
    couples = min(males, females)

    if policy == 'one child':
        children = get_children(couples, male_portion, fertility)
    elif policy == 'one son':
        # First try at getting a child
        children = get_children(couples, male_portion, fertility)
        # Continue with getting a new child for each daughter
        daughters = children[children == FEMALE]
        while len(daughters) > 0:
            new_children = get_children(len(daughters),
                                       male_portion, fertility)
            children = np.concatenate((children, new_children))
            daughters = new_children[new_children == FEMALE]
    return children
```

The simulation is then a matter of repeated calls to `advance_generation`:

```
N = 1000000          # population size
male_portion = 0.51
fertility = 0.92
# Start with a "perfect" generation of parents
parents = get_children(N, male_portion=0.5, fertility=1.0)
print 'one son policy, start: %d' % len(parents)
for i in range(10):
    parents = advance_generation(parents, 'one son',
                                male_portion, fertility)
    print '%3d: %d' % (i+1, len(parents))
```

Under ideal conditions with unit fertility and a `male_portion` of 0.5, the program predicts that the “one child” policy halves the population from one generation to the next, while the “one son” policy, where we expect each couple to get one daughter and one son on average, keeps the population constant. Increasing `male_portion` slightly and decreasing `fertility`, which corresponds more to reality, will in both cases lead to a reduction of the population. You can try the program out with various values of these input parameters.

An obvious extension is to incorporate the effect that a portion of the population does not follow the policy and get c children on average. The program `birth_policy.py` can account for the effect, which is quite dramatic: If 1% of the population does not follow the “one son” policy and get 4 children on average, the population grows with 50% over 10 generations (`male_portion` and `fertility` kept at the ideal values 0.5 and 1, respectively).

Normally, simple models like the difference equations (A.9) and (A.12), from Appendices A.1.4 and A.1.5, or the differential equations (C.11) or (C.23), are used to model population growth. However, these models track the number of individuals through time with a very simple growth factor from one generation to the next. The model above tracks each individual in the population and applies rules involving random actions to each individual. Such a detailed and much more computer-time consuming model can be used to see the effect of different policies. Using the results of this detailed model, we can (sometimes) estimate growth factors for simpler models so that these mimic the overall effect on the population size. Exercise 8.28 asks you to investigate if a certain realization of the “one son” policy leads to simple exponential growth.

8.4 Simple Games

This section presents the implementation of some simple games based on drawing random numbers. The games can be played by two humans, but here we consider a human versus the computer.

8.4.1 Guessing a Number

The Game. The computer determines a secret number, and the player shall guess the number. For each guess, the computer tells if the number is too high or too low.

The Implementation. We let the computer draw a random integer in an interval known to the player, let us say $[1, 100]$. In a `while` loop the program prompts the player for a guess, reads the guess, and checks if the guess is higher or lower than the drawn number. An appropriate message is written to the screen. We think the algorithm can be expressed directly as executable Python code:

```
import random
number = random.randint(1, 100)
attempts = 0 # count no of attempts to guess the number
guess = 0
while guess != number:
    guess = eval(raw_input('Guess a number: '))
    attempts += 1
```

```

if guess == number:
    print 'Correct! You used', attempts, 'attempts!'
    break
elif guess < number:
    print 'Go higher!'
else:
    print 'Go lower!'

```

The program is available as the file `guessnumber.py`. Try it out! Can you come up with a strategy for reducing the number of attempts? See Exercise 8.29 for an automatic investigation of two possible strategies.

8.4.2 Rolling Two Dice

The Game. The player is supposed to roll two dice, and beforehand guess the sum of the eyes. If the guess on the sum is n and it turns out to be right, the player earns n euros. Otherwise, the player must pay 1 euro. The machine plays in the same way, but the machine's guess of the number of eyes is a uniformly distributed number between 2 and 12. The player determines the number of rounds, r , to play, and receives r euros as initial capital. The winner is the one that has the largest amount of euros after r rounds, or the one that avoids to lose all the money.

The Implementation. There are three actions that we can naturally implement as functions: (i) roll two dice and compute the sum; (ii) ask the player to guess the number of eyes; (iii) draw the computer's guess of the number of eyes. One soon realizes that it is as easy to implement this game for an arbitrary number of dice as it is for two dice. Consequently we can introduce `ndice` as the number of dice. The three functions take the following forms:

```

import random

def roll_dice_and_compute_sum(ndice):
    return sum([random.randint(1, 6) \
                for i in range(ndice)])

def computer_guess(ndice):
    return random.randint(ndice, 6*ndice)

def player_guess(ndice):
    return input('Guess the sum of the no of eyes '\
                'in the next throw: ')

```

We can now implement one round in the game for the player or the computer. The round starts with a capital, a guess is performed by calling the right function for guessing, and the capital is updated:

```

def play_one_round(ndice, capital, guess_function):
    guess = guess_function(ndice)
    throw = roll_dice_and_compute_sum(ndice)
    if guess == throw:

```

```

        capital += guess
    else:
        capital -= 1
    return capital, throw, guess

```

Here, `guess_function` is either `computer_guess` or `player_guess`.

With the `play_one_round` function we can run a number of rounds involving both players:

```

def play(nrounds, ndice=2):
    player_capital = computer_capital = nrounds # start capital

    for i in range(nrounds):
        player_capital, throw, guess = \
            play_one_round(ndice, player_capital, player_guess)
        print 'YOU guessed %d, got %d' % (guess, throw)

        computer_capital, throw, guess = \
            play_one_round(ndice, computer_capital, computer_guess)
        print 'Machine guessed %d, got %d' % (guess, throw)

        print 'Status: you have %d euros, machine has %d euros' % \
            (player_capital, computer_capital)

        if player_capital == 0 or computer_capital == 0:
            break

    if computer_capital > player_capital:
        winner = 'Machine'
    else:
        winner = 'You'
    print winner, 'won!'

```

The name of the program is `ndice.py`.

Example. Here is a session (with a fixed seed of 20):

```

Guess the sum of the no of eyes in the next throw: 7
YOU guessed 7, got 11
Machine guessed 10, got 8
Status: you have 9 euros, machine has 9 euros

Guess the sum of the no of eyes in the next throw: 9
YOU guessed 9, got 10
Machine guessed 11, got 6
Status: you have 8 euros, machine has 8 euros

Guess the sum of the no of eyes in the next throw: 9
YOU guessed 9, got 9
Machine guessed 3, got 8
Status: you have 17 euros, machine has 7 euros

```

Exercise 8.11 asks you to perform simulations to determine whether a certain strategy can make the player win over the computer in the long run.

A Class Version. We can cast the previous code segment in a class. Many will argue that a class-based implementation is closer to the problem being modeled and hence easier to modify or extend.

A natural class is `Dice`, which can throw `n` dice:

```
class Dice:
    def __init__(self, n=1):
        self.n = n    # no of dice

    def throw(self):
        return [random.randint(1,6) \
                for i in range(self.n)]
```

Another natural class is `Player`, which can perform the actions of a player. Functions can then make use of `Player` to set up a game. A `Player` has a name, an initial capital, a set of dice, and a `Dice` object to throw the object:

```
class Player:
    def __init__(self, name, capital, guess_function, ndice):
        self.name = name
        self.capital = capital
        self.guess_function = guess_function
        self.dice = Dice(ndice)

    def play_one_round(self):
        self.guess = self.guess_function(self.dice.n)
        self.throw = sum(self.dice.throw())
        if self.guess == self.throw:
            self.capital += self.guess
        else:
            self.capital -= 1
        self.message()
        self.broke()

    def message(self):
        print '%s guessed %d, got %d' % \
              (self.name, self.guess, self.throw)

    def broke(self):
        if self.capital == 0:
            print '%s lost!' % self.name
            sys.exit(0) # end the program
```

The guesses of the computer and the player are specified by functions:

```
def computer_guess(ndice):
    # All guesses have the same probability
    return random.randint(ndice, 6*ndice)

def player_guess(ndice):
    return input('Guess the sum of the no of eyes '\
                'in the next throw: ')
```

The key function to play the whole game, utilizing the `Player` class for the computer and the user, can be expressed as

```
def play(nrounds, ndice=2):
    player = Player('YOU', nrounds, player_guess, ndice)
    computer = Player('Computer', nrounds, computer_guess, ndice)

    for i in range(nrounds):
        player.play_one_round()
```

```

computer.play_one_round()
print 'Status: user have %d euro, machine has %d euro\n' % \
      (player.capital, computer.capital)

if computer.capital > player.capital:
    winner = 'Machine'
else:
    winner = 'You'
print winner, 'won!'

```

The complete code is found in the file `ndice2.py`. There is no new functionality compared to the `ndice.py` implementation, just a new and better structuring of the code.

8.5 Monte Carlo Integration

One of the earliest applications of random numbers was numerical computation of integrals, that is, a non-random (deterministic) problem. Here we shall address two related methods for computing $\int_a^b f(x)dx$.

8.5.1 Standard Monte Carlo Integration

Let x_1, \dots, x_n be uniformly distributed random numbers between a and b . Then

$$(b - a) \frac{1}{n} \sum_{i=1}^n f(x_i) \quad (8.7)$$

is an approximation to the integral $\int_a^b f(x)dx$. This method is usually referred to as *Monte Carlo integration*. It is easy to interpret (8.7). A well-known result from calculus is that the integral of a function f over $[a, b]$ equals the mean value of f over $[a, b]$ multiplied by the length of the interval, $b - a$. If we approximate the mean value of $f(x)$ by the mean of n randomly distributed function evaluations $f(x_i)$, we get the method (8.7).

We can implement (8.7) in a small function:

```

import random

def MCint(f, a, b, n):
    s = 0
    for i in range(n):
        x = random.uniform(a, b)
        s += f(x)
    I = (float(b-a)/n)*s
    return I

```

One normally needs a large n to obtain good results with this method, so a faster vectorized version of the `MCint` function is handy:

```
import numpy as np

def MCint_vec(f, a, b, n):
    x = np.random.uniform(a, b, n)
    s = np.sum(f(x))
    I = (float(b-a)/n)*s
    return I
```

Let us try the Monte Carlo integration method on a simple linear function $f(x) = 2 + 3x$, integrated from 1 to 2. Most other numerical integration methods will integrate such a linear function exactly, regardless of the number of function evaluations. This is not the case with Monte Carlo integration. It would be interesting to see how the quality of the Monte Carlo approximation increases with n . To plot the evolution of the integral approximation we must store intermediate I values. This requires a slightly modified `MCint` method:

```
def MCint2(f, a, b, n):
    s = 0
    # Store the intermediate integral approximations in an
    # array I, where I[k-1] corresponds to k function evals.
    I = np.zeros(n)
    for k in range(1, n+1):
        x = random.uniform(a, b)
        s += f(x)
        I[k-1] = (float(b-a)/k)*s
    return I
```

Note that we let k go from 1 to n while the indices in I , as usual, go from 0 to $n-1$. Since n can be very large, the I array may consume more memory than what we have on the computer. Therefore, we decide to store only every N values of the approximation. Determining if a value is to be stored or not can then be computed by the `mod` function (see page 119):

```
for k in range(1, n+1):
    ...
    if k % N == 0:
        # store
```

That is, every time k can be divided by N without any remainder, we store the value. The complete function takes the following form:

```
def MCint3(f, a, b, n, N=100):
    s = 0
    # Store every N intermediate integral approximations in an
    # array I and record the corresponding k value.
    I_values = []
    k_values = []
    for k in range(1, n+1):
        x = random.uniform(a, b)
        s += f(x)
        if k % N == 0:
            I = (float(b-a)/k)*s
            I_values.append(I)
            k_values.append(k)
    return k_values, I_values
```

Now we have the tools to plot the error in the Monte Carlo approximation as a function of n :

```
def f1(x):
    return 2 + 3*x

k, I = MCint3(f1, 1, 2, 1000000, N=10000)

from scitools.std import plot
error = 6.5 - np.array(I)
plot(k, error, title='Monte Carlo integration',
      xlabel='n', ylabel='error')
```

Figure 8.4 shows the resulting plot.

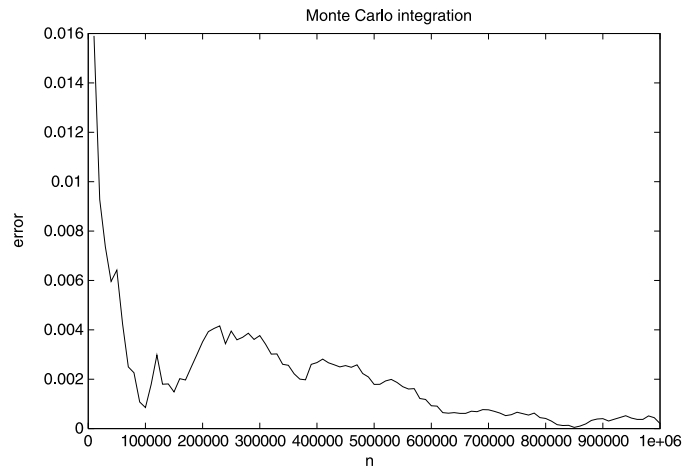

Fig. 8.4 The convergence of Monte Carlo integration applied to $\int_1^2 (2 + 3x)dx$.

For functions of one variable, method (8.7) requires many points and is inefficient compared to other integration rules. Most integration rules have an error that reduces with increasing n , typically like n^{-r} for some $r > 0$. For the Trapezoidal rule, $r = 2$, while $r = 1/2$ for Monte Carlo integration, which means that this method converges quite slowly compared to the Trapezoidal rule. However, for functions of many variables, Monte Carlo integration in high space dimension completely outperforms methods like the Trapezoidal rule and Simpson's rule. There are also many ways to improve the performance of (8.7), basically by being “smart” in drawing the random numbers (this is called variance reducing techniques).

8.5.2 Area Computing by Throwing Random Points

Think of some geometric region G in the plane and a surrounding bounding box B with geometry $[x_L, x_H] \times [y_L, y_H]$. One way of computing the area of G is to draw N random points inside B and count how

many of them, M , that lie inside G . The area of G is then the fraction M/N (G 's fraction of B 's area) times the area of B , $(x_H - x_L)(y_H - y_L)$. Phrased differently, this method is a kind of dart game where you record how many hits there are inside G if every throw hits uniformly within B .

Let us formulate this method for computing the integral $\int_a^b f(x)dx$. The important observation is that this integral is the area under the curve $y = f(x)$ and above the x axis, between $x = a$ and $x = b$. We introduce a rectangle B ,

$$B = \{(x, y) \mid a \leq x \leq b, 0 \leq y \leq m\},$$

where $m \leq \max_{x \in [a, b]} f(x)$. The algorithm for computing the area under the curve is to draw N random points inside B and count how many of them, M , that are above the x axis and below the $y = f(x)$ curve, see Figure 8.5. The area or integral is then estimated by

$$\frac{M}{N}m(b - a).$$

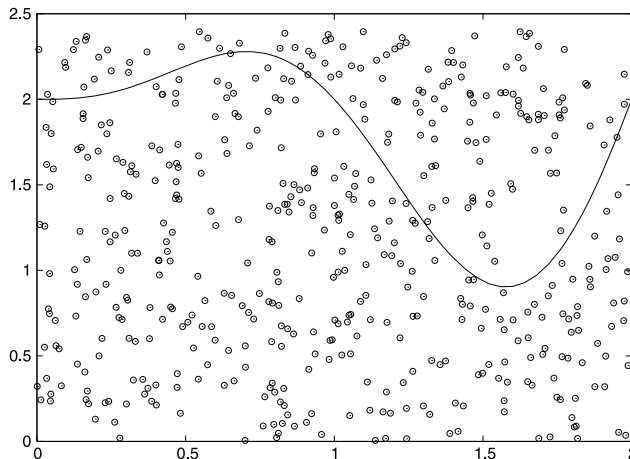

Fig. 8.5 The “dart” method for computing integrals. When M out of N random points in the rectangle $[0, 2] \times [0, 2.4]$ lie under the curve, the area under the curve is estimated as the M/N fraction of the area of the rectangle, i.e., $(M/N)2 \cdot 2.4$.

First we implement the “dart method” by a simple loop over points:

```
def MCint_area(f, a, b, n, m):
    below = 0 # counter for no of points below the curve
    for i in range(n):
        x = random.uniform(a, b)
        y = random.uniform(0, m)
        if y <= f(x):
            below += 1
    area = below/float(n)*m*(b-a)
    return area
```

Note that this method draws twice as many random numbers as the previous method.

A vectorized implementation reads

```
import numpy as np

def MCint_area_vec(f, a, b, n, m):
    x = np.random.uniform(a, b, n)
    y = np.random.uniform(0, m, n)
    below = y[y < f(x)].size
    area = below/float(n)*m*(b-a)
    return area
```

The only non-trivial line here is the expression `y[y < f(x)]`, which applies boolean indexing (Chapter 5.5.2) to extract the `y` values that are below the `f(x)` curve. The size of `y[y < f(x)]` gives the number of points below the curve.

Even for 2 million random numbers the plain loop version is not that slow as it executes within some seconds on a slow laptop. Nevertheless, if you need the integration being repeated many times inside another calculation, the superior efficiency of the vectorized version may be important. We can quantify the efficiency gain by the aid of the timer `time.clock()` in the following way (see Appendix H.6.1):

```
import time
t0 = time.clock()
print MCint_area(f1, a, b, n, fmax)
t1 = time.clock() # time of MCint_area is t1-t0
print MCint_area_vec(f1, a, b, n, fmax)
t2 = time.clock() # time of MCint_area_vec is t2-t1
print 'loop/vectorized fraction:', (t1-t0)/(t2-t1)
```

With $n = 10^6$ the author achieved a factor of about 8 in favor of the vectorized version.

8.6 Random Walk in One Space Dimension

In this section we shall simulate a collection of particles that move around in a random fashion. This type of simulations are fundamental in physics, biology, chemistry as well as other sciences and can be used to describe many phenomena. Some application areas include molecular motion, heat conduction, quantum mechanics, polymer chains, population genetics, brain research, hazard games, and pricing of financial instruments.

Imagine that we have some particles that perform random moves, either to the right or to the left. We may flip a coin to decide the movement of each particle, say head implies movement to the right and tail means movement to the left. Each move is one unit length.

Physicists use the term *random walk* for this type of movement of a particle⁷.

The movement is also known as “drunkard’s walk”. You may have experienced this after a very wet night on a pub: you step forward and backward in a random fashion. Since these movements on average make you stand still, and since you know that you normally reach home within reasonable time, the model is not good for a real walk. We need to add a *drift* to the walk, so the probability is greater for going forward than backward. This is an easy adjustment, see Exercise 8.34. What may come as a surprise is the following fact: even when there is equal probability of going forward and backward, one can prove mathematically that the drunkard will always reach his home. Or more precisely, he will get home in finite time (“almost surely” as the mathematicians must add to this statement). Exercise 8.35 asks you to experiment with this fact. For many practical purposes, “finite time” does not help much as there might be more steps involved than the time it takes to get sufficiently sober to remove the completely random component of the walk.

8.6.1 Basic Implementation

How can we implement n_s random steps of n_p particles in a program? Let us introduce a coordinate system where all movements are along the x axis. An array of x values then holds the positions of all particles. We draw random numbers to simulate flipping a coin, say we draw from the integers 1 and 2, where 1 means head (movement to the right) and 2 means tail (movement to the left). We think the algorithm is conveniently expressed directly as a complete Python program:

```
import random
import numpy
np = 4                # no of particles
ns = 100             # no of steps
positions = numpy.zeros(np) # all particles start at x=0
HEAD = 1; TAIL = 2   # constants

for step in range(ns):
    for p in range(np):
        coin = random.randint(1,2) # flip coin
        if coin == HEAD:
            positions[p] += 1 # one unit length to the right
        elif coin == TAIL:
            positions[p] -= 1 # one unit length to the left
```

This program is found in the file `walk1D.py`.

⁷ You may try this yourself: flip the coin and make one step to the left or right, and repeat this process.

8.6.2 Visualization

We may add some visualization of the movements by inserting a `plot` command at the end of the `step` loop and a little pause to better separate the frames in the animation⁸:

```
plot(positions, y, 'ko3', axis=[xmin, xmax, -0.2, 0.2])
time.sleep(0.2) # pause
```

Recall from Chapter 5 that in an animation like this the axis must be kept fixed. We know that in n_s steps, no particle can move longer than n_s unit lengths to the right or to the left so the extent of the x axis becomes $[-n_s, n_s]$. However, the probability of reaching these lower or upper limit is very small⁹. Most of the movements will take place in the center of the plot. We may therefore shrink the extent of the axis to better view the movements. It is known that the expected extent of the particles is of the order $\sqrt{n_s}$, so we may take the maximum and minimum values in the plot as $\pm 2\sqrt{n_s}$. However, if a position of a particle exceeds these values, we extend `xmax` and `xmin` by $2\sqrt{n_s}$ in positive and negative x direction, respectively.

The y positions of the particles are taken as zero, but it is necessary to have some extent of the y axis, otherwise the coordinate system collapses and most plotting packages will refuse to draw the plot. Here we have just chosen the y axis to go from -0.2 to 0.2 . You can find the complete program in `src/random/walk1Dp.py`. The `np` and `ns` parameters can be set as the first two command-line arguments:

Terminal

```
walk1Dp.py 6 200
```

It is hard to claim that this program has astonishing graphics. In Chapter 8.7, where we let the particles move in two space dimensions, the graphics gets much more exciting.

8.6.3 Random Walk as a Difference Equation

The random walk process can easily be expressed in terms of a difference equation (see Appendix A for an introduction to difference equations). Let x_n be the position of the particle at time n . This position is an evolution from time $n - 1$, obtained by adding a random variable s to the previous position x_{n-1} , where $s = 1$ has probability $1/2$ and $s = -1$ has probability $1/2$. In statistics, the expression “probability of event A” is written $P(A)$. We can therefore write $P(s = 1) = 1/2$ and $P(s = -1) = 1/2$. The difference equation can now be expressed mathematically as

⁸ These actions require `from scitools.std import *` and `import time`.

⁹ The probability is 2^{-n_s} , which becomes about 10^{-9} for 30 steps.

$$x_n = x_{n-1} + s, \quad x_0 = 0, \quad P(s = 1) = P(s = -1) = 1/2. \quad (8.8)$$

This equation governs the motion of one particle. For a collection m of particles we introduce $x_n^{(i)}$ as the position of the i -th particle at the n -th time step. Each $x_n^{(i)}$ is governed by (8.8), and all the s values in each of the m difference equations are independent of each other.

8.6.4 Computing Statistics of the Particle Positions

Scientists interested in random walks are in general not interested in the graphics of our `walk1D.py` program, but more in the statistics of the positions of the particles at each step. We may therefore, at each step, compute a histogram of the distribution of the particles along the x axis, plus estimate the mean position and the standard deviation. These mathematical operations are easily accomplished by letting the SciTools function `compute_histogram` and the numpy functions `mean` and `std` operate on the `positions` array (see Chapter 8.1.5)¹⁰:

```
mean_pos = numpy.mean(positions)
stdev_pos = numpy.std(positions)
pos, freq = compute_histogram(positions, nbins=int(xmax),
                              piecewise_constant=True)
```

We can plot the particles as circles, as before, and add the histogram and vertical lines for the mean and the positive and negative standard deviation (the latter indicates the “width” of the distribution of particles). The vertical lines can be defined by the six lists

```
xmean, ymean = [mean_pos, mean_pos], [yminv, ymaxv]
xstdv1, ystdv1 = [stdev_pos, stdev_pos], [yminv, ymaxv]
xstdv2, ystdv2 = [-stdev_pos, -stdev_pos], [yminv, ymaxv]
```

where `yminv` and `ymaxv` are the minimum and maximum y values of the vertical lines. The following command plots the position of every particle as circles, the histogram as a curve, and the vertical lines with a thicker line:

```
plot(positions, y, 'ko3', # particles as circles
      pos, freq, 'r', # histogram
      xmean, ymean, 'r2', # mean position as thick line
      xstdv1, ystdv1, 'b2', # +1 standard dev.
      xstdv2, ystdv2, 'b2', # -1 standard dev.
      axis=[xmin, xmax, ymin, ymax],
      title='random walk of %d particles after %d steps' %
            (np, step+1))
```

This plot is then created at every step in the random walk. By observing the graphics, one will soon realize that the computation of the extent

¹⁰ The number of bins in the histogram is just based on the extent of the particles. It could also have been a fixed number.

of the y axis in the plot needs some considerations. We have found it convenient to base y_{\max} on the maximum value of the histogram ($\max(\text{freq})$), plus some space (chosen as 10 percent of $\max(\text{freq})$). However, we do not change the y_{\max} value unless it is more than 0.1 different from the previous y_{\max} value (otherwise the axis “jumps” too often). The minimum value, y_{\min} , is set to $y_{\min} = -0.1 * y_{\max}$ every time we change the y_{\max} value. The complete code is found in the file `walk1Ds.py`. If you try out 2000 particles and 30 steps, the final graphics becomes like that in Figure 8.6. As the number of steps is increased, the particles are dispersed in the positive and negative x direction, and the histogram gets flatter and flatter. Letting $\hat{H}(i)$ be the histogram value in interval number i , and each interval having width Δx , the probability of finding a particle in interval i is $\hat{H}(i)\Delta x$. It can be shown mathematically that the histogram is an approximation to the probability density function of the normal distribution (1.6) (see page 45), with mean zero and standard deviation $s \sim \sqrt{n}$, where n is the step number.

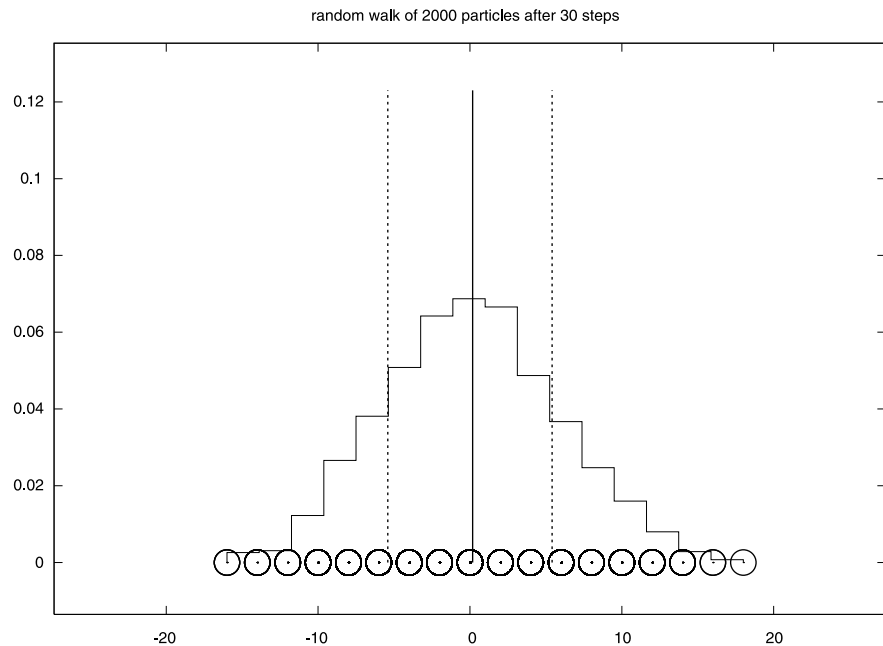

Fig. 8.6 Particle positions (circles), histogram (piecewise constant curve), and vertical lines indicating the mean value and the standard deviation from the mean after a one-dimensional random walk of 2000 particles for 30 steps.

8.6.5 Vectorized Implementation

There is no problem with the speed of our one-dimensional random walkers in the `walk1Dp.py` or `walk1Ds.py` programs, but in real-life ap-

plications of such simulation models, we often have a very large number of particles performing a very large number of steps. It is then important to make the implementation as efficient as possible. Two loops over all particles and all steps, as we have in the programs above, become very slow compared to a vectorized implementation.

A vectorized implementation of a one-dimensional walk should utilize the functions `randint` or `random_integers` from `numpy`'s `random` module. A first idea may be to draw steps for all particles at a step simultaneously. Then we repeat this process in a loop from 0 to $n_s - 1$. However, these repetitions are just new vectors of random numbers, and we may avoid the loop if we draw $n_p \times n_s$ random numbers at once:

```
moves = numpy.random.randint(1, 3, size=np*ns)
# or
moves = numpy.random.random_integers(1, 2, size=np*ns)
```

The values are now either 1 or 2, but we want -1 or 1 . A simple scaling and translation of the numbers transform the 1 and 2 values to -1 and 1 values:

```
moves = 2*moves - 3
```

Then we can create a two-dimensional array out of `moves` such that `moves[i,j]` is the i -th step of particle number j :

```
moves.shape = (ns, np)
```

It does not make sense to plot the evolution of the particles and the histogram in the vectorized version of the code, because the point with vectorization is to speed up the calculations, and the visualization takes much more time than drawing random numbers, even in the `walk1Dp.py` and `walk1Ds.py` programs from Chapter 8.6.4. We therefore just compute the positions of the particles inside a loop over the steps and some simple statistics. At the end, after n_s steps, we plot the histogram of the particle distribution along with circles for the positions of the particles. The rest of the program, found in the file `walk1Dv.py`, looks as follows:

```
positions = numpy.zeros(np)
for step in range(ns):
    positions += moves[step, :]

    mean_pos = numpy.mean(positions)
    stdev_pos = numpy.std(positions)
    print mean_pos, stdev_pos

nbins = int(3*sqrt(ns)) # no of intervals in histogram
pos, freq = compute_histogram(positions, nbins,
                              piecewise_constant=True)

plot(positions, zeros(np), 'ko3',
      pos, freq, 'r',
      axis=[min(positions), max(positions), -0.01, 1.1*max(freq)],
      savefig='tmp.ps')
```

8.7 Random Walk in Two Space Dimensions

A random walk in two dimensions performs a step either to the north, south, west, or east, each one with probability $1/4$. To demonstrate this process, we introduce x and y coordinates of n_p particles and draw random numbers among 1, 2, 3, or 4 to determine the move. The positions of the particles can easily be visualized as small circles in an xy coordinate system.

8.7.1 Basic Implementation

The algorithm described above is conveniently expressed directly as a complete working program:

```
def random_walk_2D(np, ns, plot_step):
    xpositions = numpy.zeros(np)
    ypositions = numpy.zeros(np)
    # extent of the axis in the plot:
    xymax = 3*numpy.sqrt(ns); xymin = -xymax

    NORTH = 1; SOUTH = 2; WEST = 3; EAST = 4 # constants

    for step in range(ns):
        for i in range(np):
            direction = random.randint(1, 4)
            if direction == NORTH:
                ypositions[i] += 1
            elif direction == SOUTH:
                ypositions[i] -= 1
            elif direction == EAST:
                xpositions[i] += 1
            elif direction == WEST:
                xpositions[i] -= 1

        # Plot just every plot_step steps
        if (step+1) % plot_step == 0:
            plot(xpositions, ypositions, 'ko',
                axis=[xymin, xymax, xymin, xymax],
                title='%d particles after %d steps' %
                    (np, step+1),
                savefig='tmp_%03d.eps' % (step+1))
    return xpositions, ypositions

# main program:
import random
random.seed(10)
import sys
import numpy
from scitools.std import plot

np      = int(sys.argv[1]) # number of particles
ns      = int(sys.argv[2]) # number of steps
plot_step = int(sys.argv[3]) # plot every plot_step steps
x, y = random_walk_2D(np, ns, plot_step)
```

The program is found in the file `walk2D.py`. Figure 8.7 shows two snapshots of the distribution of 3000 particles after 40 and 400 steps. These plots were generated with command-line arguments `3000 400 20`, the

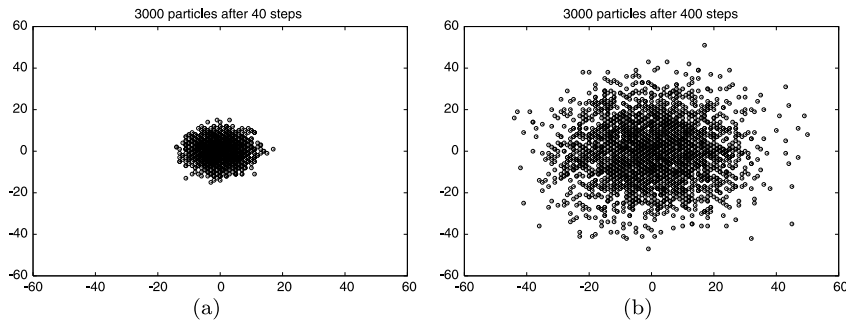

Fig. 8.7 Location of 3000 particles starting at the origin and performing a random walk: (a) 40 steps; (b) 400 steps.

latter implying that we visualize the particles every 20 time steps only.

To get a feeling for the two-dimensional random walk you can try out only 30 particles for 400 steps and let each step be visualized (i.e., command-line arguments `30 400 1`). The update of the movements is now fast.

The `walk2D.py` program dumps the plots to PostScript files with names of the form `tmp_xxx.eps`, where `xxx` is the step number. We can create a movie out of these individual files using the `movie` function (Chapter 5.3.4) or the program `convert` from the ImageMagick suite¹¹:

```
convert -delay 50 -loop 1000 tmp_*.eps movie.gif
```

All the plots are now put after each other as frames in a movie, with a delay of 50 ms between each frame. The movie will run in a loop 1000 times. Alternatively, we can create the movie with the `movie` function from `Easyviz`, inside a program:

```
from scitools.std import movie
movie('tmp_*.eps', encoder='convert', output_file='movie.gif')
```

The resulting movie file is named `movie.gif`, which can be viewed by the `animate` program (also from the ImageMagick program suite), just write `animate movie.gif`. Making and showing the movie are slow processes if a large number of steps are included in the movie – 100 steps or fewer are appropriate, but this depends on the power of your computer.

8.7.2 Vectorized Implementation

The `walk2D.py` program is quite slow. Now the visualization is much faster than the movement of the particles. Vectorization may speed up

¹¹ If you want to run this command from an IPython session, prefix `convert` with an exclamation mark: `!convert`.

the `walk2D.py` program significantly. As in the one-dimensional phase, we draw all the movements at once and then invoke a loop over the steps to update the x and y coordinates. We draw $n_s \times n_p$ numbers among 1, 2, 3, and 4. We then reshape the vector of random numbers to a two-dimensional array `moves[i, j]`, where i counts the steps, j counts the particles. The `if` test on whether the current move is to the north, south, east, or west can be vectorized using the `where` function (see Chapter 5.5.2). For example, if the random numbers for all particles in the current step are accessible in an array `this_move`, we could update the x positions by

```
xpositions += np.where(this_move == EAST, 1, 0)
xpositions -= np.where(this_move == WEST, 1, 0)
```

provided `EAST` and `WEST` are constants, equal to 3 and 4, respectively. A similar construction can be used for the y moves.

The complete program is listed below:

```
def random_walk_2D(np, ns, plot_step):
    xpositions = numpy.zeros(np)
    ypositions = numpy.zeros(np)
    moves = numpy.random.random_integers(1, 4, size=ns*np)
    moves.shape = (ns, np)

    # Estimate max and min positions
    xymax = 3*numpy.sqrt(ns); xymin = -xymax

    NORTH = 1; SOUTH = 2; WEST = 3; EAST = 4 # constants

    for step in range(ns):
        this_move = moves[step,:]
        ypositions += numpy.where(this_move == NORTH, 1, 0)
        ypositions -= numpy.where(this_move == SOUTH, 1, 0)
        xpositions += numpy.where(this_move == EAST, 1, 0)
        xpositions -= numpy.where(this_move == WEST, 1, 0)

        # Just plot every plot_step steps
        if (step+1) % plot_step == 0:
            plot(xpositions, ypositions, 'ko',
                axis=[xymin, xymax, xymin, xymax],
                title='%d particles after %d steps' %
                    (np, step+1),
                savefig='tmp_%03d.eps' % (step+1))
    return xpositions, ypositions

# Main program
from scitools.std import plot
import numpy, sys
numpy.random.seed(11)

np = int(sys.argv[1]) # number of particles
ns = int(sys.argv[2]) # number of steps
plot_step = int(sys.argv[3]) # plot each plot_step step
x, y = random_walk_2D(np, ns, plot_step)
```

You will easily experience that this program, found in the file `walk2Dv.py`, runs significantly faster than the `walk2D.py` program.

8.8 Summary

8.8.1 Chapter Topics

Drawing Random Numbers. Random numbers can be scattered throughout an interval in various ways, specified by the *distribution* of the numbers. We have considered a uniform distribution (Chapter 8.1.2) and a normal (or Gaussian) distribution (Chapter 8.1.6). Table 8.1 shows the syntax for generating random numbers of these two distributions, using either the standard scalar `random` module in Python or the vectorized `numpy.random` module.

Table 8.1 Summary of important functions for drawing random numbers. `N` is the array length in vectorized drawing, while `m` and `s` represent the mean and standard deviation values of a normal distribution. Functions from the standard `random` module appear in the middle column, while the corresponding functions from `numpy.random` are listed in the right column.

uniform numbers in $[0, 1)$	<code>random()</code>	<code>random(N)</code>
uniform numbers in $[a, b)$	<code>uniform(a, b)</code>	<code>uniform(a, b, N)</code>
integers in $[a, b]$	<code>randint(a, b)</code>	<code>randint(a, b+1, N)</code>
		<code>random_integers(a, b, N)</code>
Gaussian numbers, mean m , st.dev. s	<code>gauss(m, s)</code>	<code>normal(m, s, N)</code>
set seed (i)	<code>seed(i)</code>	<code>seed(i)</code>
shuffle list a (in-place)	<code>shuffle(a)</code>	<code>shuffle(a)</code>
choose a random element in list a	<code>choice(a)</code>	

Typical Probability Computation. Many programs performing probability computations draw a large number `N` of random numbers and count how many times `M` a random number leads to some true condition (Monte Carlo simulation):

```
import random
M = 0
for i in xrange(N):
    r = random.randint(a, b)
    if condition:
        M += 1
print 'Probability estimate:', float(M)/N
```

For example, if we seek the probability that we get at least four eyes when throwing a dice, we choose the random number to be the number of eyes, i.e., an integer in the interval $[1, 6]$ (`a=1`, `b=6`) and `condition` becomes `r >= 4`.

For large `N` we can speed up such programs by vectorization, i.e., drawing all random numbers at once in a big array and use operations on the array to find `M`. The similar vectorized version of the program above looks like

```
import numpy as np
r = np.random.uniform(a, b, N)
M = np.sum(condition)
# or
```

```
M = np.sum(where(condition, 1, 0))
print 'Probability estimate:', float(M)/N
```

(Combinations of boolean expressions in the `condition` argument to `where` requires special constructs as outlined in Exercise 8.18.) Make sure you use `np.sum` when operating on large arrays and not the much slower built-in `sum` function in Python.

Statistical Measures. Given an array of random numbers, the following code computes the mean, variance, and standard deviation of the numbers and finally displays a plot of the histogram, which reflects how the numbers are statistically distributed:

```
from scitools.std import compute_histogram, plot
import numpy as np
m = np.mean(numbers)
v = np.var(numbers)
s = np.std(numbers)
x, y = compute_histogram(numbers, 50, piecewise_constant=True)
plot(x, y)
```

8.8.2 Example: Random Growth

Appendix A.1.1 presents simple mathematical models for how an investment grows when there is an interest rate being added to the investment at certain intervals. The models can easily allow for a time-varying interest rate, but for forecasting the growth of an investment, it is difficult to predict the future interest rate. One commonly used method is to build a probabilistic model for the development of the interest rate, where the rate is chosen randomly at random times. This gives a random growth of the investment, but by simulating many random scenarios we can compute the mean growth and use the standard deviation as a measure of the uncertainty of the predictions.

Problem. Let p be the annual interest rate in a bank in percent. Suppose the interest is added to the investment q times per year. The new value of the investment, x_n , is given by the previous value of the investment, x_{n-1} , plus the p/q percent interest:

$$x_n = x_{n-1} + \frac{p}{100q}x_{n-1}.$$

Normally, the interest is added daily ($q = 360$ and n counts days), but for efficiency in the computations later we shall assume that the interest is added monthly, so $q = 12$ and n counts months.

The basic assumption now is that p is random and varies with time. Suppose p increases with a random amount γ from one month to the next:

$$p_n = p_{n-1} + \gamma.$$

A typical size of p adjustments is 0.5. However, the central bank does not adjust the interest every month. Instead this happens every M months on average. The probability of a $\gamma \neq 0$ can therefore be taken as $1/M$. In a month where $\gamma \neq 0$, we may say that $\gamma = m$ with probability $1/2$ or $\gamma = -m$ with probability $1/2$ if it is equally likely that the rate goes up as down (this is not a good assumption, but a more complicated change in γ is postponed now).

Solution. First we must develop the precise formulas to be implemented. The difference equations for x_n and p_n are simple in the present case, but the details of computing γ must be worked out.

In a program, we can draw two random numbers to estimate γ : one for deciding if $\gamma \neq 0$ and the other for determining the sign of the change. Since the probability for $\gamma \neq 0$ is $1/M$, we can draw a number r_1 among the integers $1, \dots, M$ and if $r_1 = 1$ we continue with drawing a second number r_2 among the integers 1 and 2. If $r_2 = 1$ we set $\gamma = m$, and if $r_2 = 2$ we set $\gamma = -m$. We must also assure that p_n does not take on unreasonable values, so we choose $p_n < 1$ and $p_n > 15$ as cases where p_n is not changed.

The mathematical model for the investment must track both x_n and p_n . Below we express with precise mathematics the equations for x_n and p_n and the computation of the random γ quantity:

$$x_n = x_{n-1} + \frac{p_{n-1}}{12 \cdot 100} x_{n-1}, \quad i = 1, \dots, N \quad (8.9)$$

$$r_1 = \text{random integer in } [1, M] \quad (8.10)$$

$$r_2 = \text{random integer in } [1, 2] \quad (8.11)$$

$$\gamma = \begin{cases} m, & \text{if } r_1 = 1 \text{ and } r_2 = 1, \\ -m, & \text{if } r_1 = 1 \text{ and } r_2 = 2, \\ 0, & \text{if } r_1 \neq 1 \end{cases} \quad (8.12)$$

$$p_n = p_{n-1} + \begin{cases} \gamma, & \text{if } p_{n-1} + \gamma \in [1, 15], \\ 0, & \text{otherwise} \end{cases} \quad (8.13)$$

We remark that the evolution of p_n is much like a random walk process (Chapter 8.6), the only differences is that the plus/minus steps are taken at some random points among the times $0, 1, 2, \dots, N$ rather than at all times $0, 1, 2, \dots, N$. The random walk for p_n also has barriers at $p = 1$ and $p = 15$, but that is common in a standard random walk too.

Each time we calculate the x_n sequence in the present application, we get a different development because of the random numbers involved. We say that one development of x_0, \dots, x_n is a *path* (or realization, but since the realization can be viewed as a curve x_n or p_n versus n in this case, it is common to use the word path). Our Monte Carlo simulation approach consists of computing a large number of paths, as well as the sum of the path and the sum of the paths squared. From the latter two

sums we can compute the mean and standard deviation of the paths to see the average development of the investment and the uncertainty of this development. Since we are interested in complete paths, we need to store the complete sequence of x_n for each path. We may also be interested in the statistics of the interest rate so we store the complete sequence p_n too.

Programs should be built in pieces so that we can test each piece before testing the whole program. In the present case, a natural piece is a function that computes one path of x_n and p_n with N steps, given M , m , and the initial conditions x_0 and p_0 . We can then test this function before moving on to calling the function a large number of times. An appropriate code may be

```
def simulate_one_path(N, x0, p0, M, m):
    x = np.zeros(N+1)
    p = np.zeros(N+1)
    index_set = range(0, N+1)

    x[0] = x0
    p[0] = p0

    for n in index_set[1:]:
        x[n] = x[n-1] + p[n-1]/(100.0*12)*x[n-1]

        # Update interest rate p
        r = random.randint(1, M)
        if r == 1:
            # Adjust gamma
            r = random.randint(1, 2)
            gamma = m if r == 1 else -m
        else:
            gamma = 0
        pn = p[n-1] + gamma
        p[n] = pn if 1 <= pn <= 15 else p[n-1]
    return x, p
```

Testing such a function is challenging because the result is different each time because of the random numbers. A first step in verifying the implementation is to turn off the randomness ($m = 0$) and check that the deterministic parts of the difference equations are correctly computed:

```
x, p = simulate_one_path(3, 1, 10, 1, 0)
print x
```

The output becomes

```
[ 1.          1.00833333  1.01673611  1.02520891]
```

These numbers can quickly be checked against a formula of the type (A.4) on page 559 in an interactive session:

```
>>> def g(x0, n, p):
...     return x0*(1 + p/(12.*100))**n
...
>>> g(1, 1, 10)
1.0083333333333333
```



```
>>> g(1, 2, 10)
1.0167361111111111
>>> g(1, 3, 10)
1.0252089120370369
```

We can conclude that our function works well when there is no randomness. A next step is to carefully examine the code that computes `gamma` and compare with the mathematical formulas.

Simulating many paths and computing the average development of x_n and p_n is a matter of calling `simulate_one_path` repeatedly, use two arrays `xm` and `pm` to collect the sum of `x` and `p`, respectively, and finally obtain the average path by dividing `xm` and `pm` by the number of paths we have computed:

```
def simulate_n_paths(n, N, L, p0, M, m):
    xm = np.zeros(N+1)
    pm = np.zeros(N+1)
    for i in range(n):
        x, p = simulate_one_path(N, L, p0, M, m)
        # Accumulate paths
        xm += x
        pm += p
    # Compute average
    xm /= float(n)
    pm /= float(n)
    return xm, pm
```

We can also compute the standard deviation of the paths using formulas (8.3) and (8.6), with x_j as either an `x` or a `p` array. It might happen that small round-off errors generate a small *negative* variance, which mathematically should have been slightly greater than zero. Taking the square root will then generate complex arrays and problems with plotting. To avoid this problem, we therefore replace all negative elements by zeros in the variance arrays before taking the square root. The new lines for computing the standard deviation arrays `xs` and `ps` are indicated below:

```
def simulate_n_paths(n, N, x0, p0, M, m):
    ...
    xs = np.zeros(N+1) # standard deviation of x
    ps = np.zeros(N+1) # standard deviation of p
    for i in range(n):
        x, p = simulate_one_path(N, x0, p0, M, m)
        # Accumulate paths
        xm += x
        pm += p
        xs += x**2
        ps += p**2
    ...
    # Compute standard deviation
    xs = xs/float(n) - xm*xm # variance
    ps = ps/float(n) - pm*pm # variance
    # Remove small negative numbers (round off errors)
    xs[xs < 0] = 0
    ps[ps < 0] = 0
    xs = np.sqrt(xs)
```

```
ps = np.sqrt(ps)
return xm, xs, pm, ps
```

A remark regarding the efficiency of array operations is appropriate here. The statement `xs += x**2` could equally well, from a mathematical point of view, be written as `xs = xs + x**2`. However, in this latter statement, two extra arrays are created (one for the squaring and one for the sum), while in the former only one array (`x**2`) is made. Since the paths can be long and we make many simulations, such optimizations can be important.

One may wonder whether `x**2` is “smart” in the sense that squaring is detected and computed as `x*x`, not as a general (slow) power function. This is indeed the case for arrays, as we have investigated in the little test program `smart_power.py` in the `random` directory. This program applies time measurement methods from Appendix H.6.2.

Our `simulate_n_paths` function generates four arrays which are natural to visualize. Having a mean and a standard deviation curve, it is often common to plot the mean curve with one color or linetype and then two curves, corresponding to plus one and minus one standard deviation, with another less visible color. This gives an indication of the mean development and the uncertainty of the underlying process. We therefore make two plots: one with `xm`, `xm+xs`, and `xm-xs`, and one with `pm`, `pm+ps`, and `pm-ps`.

Both for debugging and curiosity it is handy to have some plots of a few actual paths. We may pick out 5 paths from the simulations and visualize these:

```
def simulate_n_paths(n, N, x0, p0, M, m):
    ...
    for i in range(n):
        ...
        # Show 5 random sample paths
        if i % (n/5) == 0:
            figure(1)
            plot(x, title='sample paths of investment')
            hold('on')
            figure(2)
            plot(p, title='sample paths of interest rate')
            hold('on')
            figure(1); savefig('tmp_sample_paths_investment.eps')
            figure(2); savefig('tmp_sample_paths_interestrates.eps')
    ...
    return ...
```

Note the use of `figure`: we need to hold on both figures to add new plots and switch between the figures, both for screen plotting and calls to `savefig`.

After the visualization of sample paths we make the mean \pm standard deviation plots by this code:

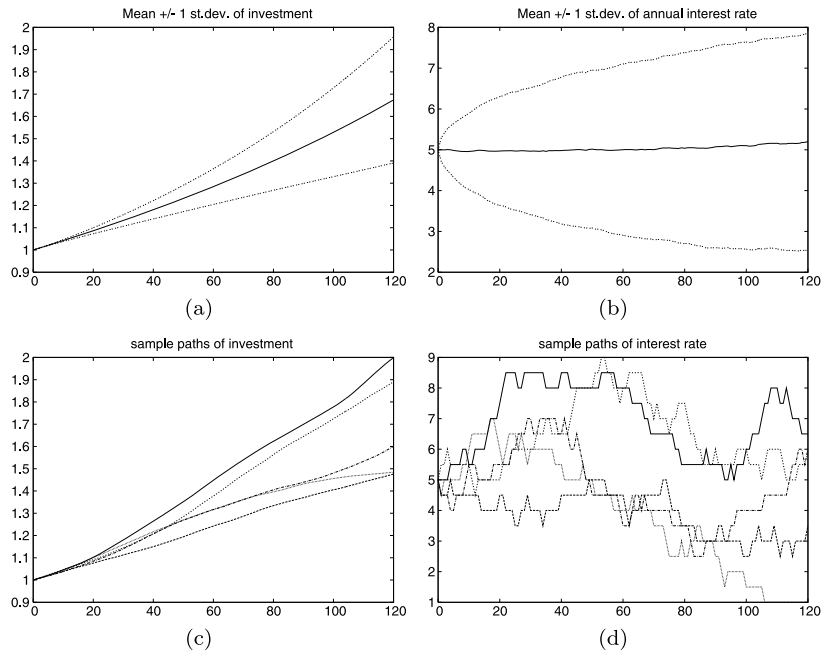

Fig. 8.8 Development of an investment with random jumps of the interest rate at random points of time: (a) mean value of investment \pm one standard deviation; (b) mean value of the interest rate \pm one standard deviation; (c) five paths of the investment development; (d) five paths of the interest rate development.

```
xm, xs, pm, ps = simulate_n_paths(n, N, x0, p0, M, m)
figure(3)
months = range(len(xm)) # indices along the x axis
plot(months, xm, 'r',
      months, xm-xs, 'y',
      months, xm+xs, 'y',
      title='Mean +/- 1 st.dev. of investment',
      savefig='tmp_mean_investment.eps')
figure(4)
plot(months, pm, 'r',
      months, pm-ps, 'y',
      months, pm+ps, 'y',
      title='Mean +/- 1 st.dev. of annual interest rate',
      savefig='tmp_mean_interestrates.eps')
```

The complete program for simulating the investment development is found in the file `growth_random.py`.

Running the program with the input data

```
x0 = 1           # initial investment
p0 = 5           # initial interest rate
N = 10*12        # number of months
M = 3            # p changes (on average) every M months
n = 1000         # number of simulations
m = 0.5          # adjustment of p
```

and initializing the seed of the random generator to 1, we get four plots, which are shown in Figure 8.8.

8.9 Exercises

Exercise 8.1. *Flip a coin N times.*

Make a program that simulates flipping a coin N times. Print out “tail” or “head” for each flip and let the program count the number of heads. (Hint: Use `r = random.random()` and define head as `r <= 0.5`, or draw an integer among $\{1, 2\}$ with `r = random.randint(1,2)` and define head when `r` is 1.) Name of program file: `flip_coin.py`. \diamond

Exercise 8.2. *Compute a probability.*

What is the probability of getting a number between 0.5 and 0.6 when drawing uniformly distributed random numbers from the interval $[0, 1)$? To answer this question empirically, let a program draw N such random numbers using Python’s standard `random` module, count how many of them, M , that fall in the interval $(0.5, 0.6)$, and compute the probability as M/N . Run the program with the four values $N = 10^i$ for $i = 1, 2, 3, 6$. Name of program file: `compute_prob.py`. \diamond

Exercise 8.3. *Choose random colors.*

Suppose we have eight different colors. Make a program that chooses one of these colors at random and writes out the color. Hint: Use a list of color names and use the `choice` function in the `random` module to pick a list element. Name of program file: `choose_color.py`. \diamond

Exercise 8.4. *Draw balls from a hat.*

Suppose there are 40 balls in a hat, of which 10 are red, 10 are blue, 10 are yellow, and 10 are purple. What is the probability of getting two blue and two purple balls when drawing 10 balls at random from the hat? Name of program file: `4balls_from10.py`. \diamond

Exercise 8.5. *Computing probabilities of rolling dice.*

1. You throw a die. What is the probability of getting a 6?
2. You throw a die four times in a row. What is the probability of getting 6 all the times?
3. Suppose you have thrown the die three times with 6 coming up all times. What is the probability of getting a 6 in the fourth throw?
4. Suppose you have thrown the die 100 times and experienced a 6 in every throw. What do you think about the probability of getting a 6 in the next throw?

First try to solve the questions from a theoretical or common sense point of view. Thereafter, make functions for simulating cases 1, 2, and 3. Name of program file: `rolling_dice.py`. \diamond

Exercise 8.6. *Estimate the probability in a dice game.*

Make a program for estimating the probability of getting at least one 6 when throwing n dice. Read n and the number of experiments

from the command line. (To verify the program, you can compare the estimated probability with the exact result $11/36$ when $n = 2$.) Name of program file: `one6_ndice.py`. ◇

Exercise 8.7. *Compute the probability of hands of cards.*

Use the `Deck.py` module (in `src/random`) and the `same_rank` and `same_suit` functions from the `cards` module to compute the following probabilities by Monte Carlo simulation:

- exactly two pairs among five cards,
- four or five cards of the same suit among five cards,
- four-of-a-kind among five cards.

Name of program file: `card_hands.py`. ◇

Exercise 8.8. *Decide if a dice game is fair.*

Somebody suggests the following game. You pay 1 euro and are allowed to throw four dice. If the sum of the eyes on the dice is less than 9, you win r euros, otherwise you lose your investment. Should you play this game when $r = 10$? Answer the question by making a program that simulates the game. Read r and the number of experiments N from the command line Name of program file: `sum9_4dice.py`. ◇

Exercise 8.9. *Adjust the game in Exer. 8.8.*

It turns out that the game in Exercise 8.8 is not fair, since you lose money in the long run. The purpose of this exercise is to adjust the winning award so that the game becomes fair, i.e., that you neither lose nor win money in the long run.

Make a program that computes the probability p of getting a sum less than s when rolling n dice. Use the reasoning in Chapter 8.3.2 to find the award per game, r , that makes the game fair. Run the program from Exercise 8.8 with this r on the command line and verify that the game is now fair. Name of program file: `sum_s_ndice_fair.py`. ◇

Exercise 8.10. *Generalize the game from Chap. 8.3.2.*

Consider the game in Chapter 8.3.2. A generalization is to think as follows: you throw one die until the number of eyes is less than or equal to the previous throw. Let m be the number of throws in a game. Use Monte Carlo simulation to compute the probability of getting $m = 2, 3, 4, \dots$ (For $m \geq 6$ the throws must be exactly $1, 2, 3, 4, 5, 6, 6, 6, \dots$, and the probability of each is $1/6$, giving the total probability 6^{-m} .) If you pay 1 euro to play this game, what is the fair amount to get paid when win? Answer this question for each of the cases $m = 2, 3, 4, 5$. Use $N = 10^6$ experiments (this should suffice to estimate the probabilities for $m \leq 5$, and beyond that we have the analytical expression). Name of program file: `incr_eyes_m.py`. ◇

Exercise 8.11. *Compare two playing strategies.*

Suggest a player strategy for the game in Chapter 8.4.2. Remove the question in the `player_guess` function in the file `src/random/ndice2.py`,

and implement the chosen strategy instead. Let the program play a large number of games, and record the number of times the computer wins. Which strategy is best in the long run: the computer's or yours? Name of program file: `simulate_strategies1.py`. ◇

Exercise 8.12. *Solve Exercise 8.11 with different no. of dice.*

Solve Exercise 8.11 for two other cases with 3 and 50 dice, respectively. Name of program file: `simulate_strategies2.py`. ◇

Exercise 8.13. *Extend Exercise 8.12.*

Extend the program from Exercise 8.12 such that the computer and the player can use a different number of dice. Let the computer choose a random number of dice between 2 and 20. Experiment to find out if there is a favorable number of dice for the player. Name of program file: `simulate_strategies3.py`. ◇

Exercise 8.14. *Investigate the winning chances of some games.*

An amusement park offers the following game. A hat contains 20 balls: 5 red, 5 yellow, 3 green, and 7 brown. At a cost of $2n$ euros you can draw $4 \leq n \leq 10$ balls at random from the hat (without putting them back). Before you are allowed to look at the drawn balls, you must choose one of the following options:

1. win 60 euros if you have drawn exactly three red balls
2. win $7 + 5\sqrt{n}$ euros if you have drawn at least three brown balls
3. win $n^3 - 26$ euros if you have drawn exactly one yellow ball and one brown ball
4. win 23 euros if you have drawn at least one ball of each color

For each of the $4n$ different types of games you can play, compute the net income (per play) and the probability of winning. Is there any of the games (i.e., any combinations of n and the options 1-4) where you will win money in the long run? Name of program file: `draw_balls.py`. ◇

Exercise 8.15. *Compute probabilities of throwing two dice.*

Make a computer program for throwing two dice a large number of times. Record the sum of the eyes each time and count how many times each of the possibilities for the sum (2, 3, ..., 12) appear. A dictionary with the sum as key and count as value is convenient here. Divide the counts by the total number of trials such that you get the frequency of each possible sum. Write out the frequencies and compare them with exact probabilities. (To find the exact probabilities, set up all the 6×6 possible outcomes of throwing two dice, and then count how many of them that has a sum s for $s = 2, 3, \dots, 12$.) Name of program file: `freq_2dice.py`. ◇

Exercise 8.16. *Play with vectorized boolean expressions.*

Using the `numpy.random` module, make an array `r` containing N uniformly distributed random numbers between 0 and 1. Print out the ar-

rays `r <= 0.5`, `r[r <= 0.5]`, `where(r <= 0.5, 1, 0)` and convince yourself that you understand what these arrays express. We want to compute how many of the elements in `r` that are less than or equal to 0.5. How can this be done in a vectorized way, i.e., without explicit loops in the program, but solely with operations on complete arrays? Name of program file: `bool_vec.py`. \diamond

Exercise 8.17. *Vectorize the program from Exer. 8.1.*

Simulate flipping a coin N times and write out the number of tails. The code should be vectorized, i.e., there must be no loops in Python. Hint: Use ideas from Exercise 8.16. Name of program file: `flip_coin_vec.py`. \diamond

Exercise 8.18. *Vectorize the code in Exer. 8.2.*

The purpose of this exercise is to speed up the code in Exercise 8.2 by vectorization. Hint: First draw an array `r` with a large number of random numbers in $[0, 1)$. The simplest way to count how many elements in `r` that lie between 0.5 and 0.6, is to first extract the elements larger than 0.5: `r1 = r[r>0.5]`, and then extract the elements in `r1` that are less than 0.6 and get the size of this array: `r1[r1<0.6].size`. Name of program file: `compute_prob_vec.py`.

Remark. An alternative and more complicated method is to use the `where` function. The condition (the first argument to `where`) is now a compound boolean expression `0.5 <= r <= 0.6`, but this cannot be used with NumPy arrays. Instead one must test for `0.5 <= r` and `r <= 0.6`. The needed boolean construction in the `where` call is `operator.and_(0.5 <= r, r <= 0.6)`. See the discussion of the this topic in Chapter 5.5.3. \diamond

Exercise 8.19. *Throw dice and compute a small probability.*

Compute the probability of getting 6 eyes on all dice when rolling 7 dice. Since you need a large number of experiments in this case (see the first paragraph of Chapter 8.3), you can save quite some simulation time by using a vectorized implementation. Name of program file: `roll_7dice.py`. \diamond

Exercise 8.20. *Difference equation for random numbers.*

Simple random number generators are based on simulating difference equations. Here is a typical set of two equations:

$$x_n = (ax_{n-1} + c) \bmod m, \quad (8.14)$$

$$y_n = x_n/m, \quad (8.15)$$

for $n = 1, 2, \dots$. A seed x_0 must be given to start the sequence. The numbers y_1, y_2, \dots , represent the random numbers and x_0, x_1, \dots are “help” numbers. Although y_n is completely deterministic from

(8.14)–(8.15), the sequence y_n appears random. The mathematical expression $p \bmod q$ is coded as `p % q` in Python.

Use $a = 8121$, $c = 28411$, and $m = 134456$. Solve the system (8.14)–(8.15) in a function that generates and returns N random numbers. Make a histogram to examine the distribution of the numbers (the y_n numbers are randomly distributed if the histogram is approximately flat). Name of program file: `diffeq_random.py`. \diamond

Exercise 8.21. *Make a class for drawing balls from a hat.*

Consider the example about drawing colored balls from a hat in Chapter 8.3.3. It could be handy to have an object that acts as a hat:

```
# Make a hat with balls of 3 colors, each color appearing
# on 4 balls
hat = Hat(colors=('red', 'black', 'blue'), number_of_each_color=4)

# Draw 3 balls at random
balls = hat.draw(number_of_balls=3)
```

Realize such code with a class `Hat`. You can borrow useful code from the `balls_in_hat.py` program and ideas from Chapter 8.2.5. Use the `Hat` class to solve the probability problem from Exercise 8.4. Name of program file: `Hat.py`. \diamond

Exercise 8.22. *Independent vs. dependent random numbers.*

Generate a sequence of N independent random variables with values 0 or 1 and print out this sequence without space between the numbers (i.e., as 001011010110111010).

The next task is to generate random zeros and ones that are dependent. If the last generated number was 0, the probability of generating a new 0 is p and a new 1 is $1 - p$. Conversely, if the last generated was 1, the probability of generating a new 1 is p and a new 0 is $1 - p$. Since the new value depends on the last one, we say the variables are dependent. Implement this algorithm in a function returning an array of N zeros and ones. Print out this array in the condense format as described above.

Choose $N = 80$ and try the probabilities $p = 0.5$, $p = 0.8$ and $p = 0.9$. Can you by visual inspection of the output characterize the differences between sequences of independent and dependent random variables? Name of program file: `dependent_random_variables.py`. \diamond

Exercise 8.23. *Compute the probability of flipping a coin.*

Modify the program from either Exercise 8.1 or 8.17 to incorporate the following extensions: look at a subset $N_1 \leq N$ of the experiments and compute probability of getting a head (M_1/N_1 , where M_1 is the number of heads in N_1 experiments). Choose $N = 1000$ and print out the probability for $N_1 = 10, 100, 500, 1000$. (Generate just N numbers once in the program.) How do you think the accuracy of the computed

probability vary with N_1 ? Is the output compatible with this expectation? Name of program file: `flip_coin_prob.py`. \diamond

Exercise 8.24. *Extend Exer. 8.23.*

We address the same problem as in Exercise 8.23, but now we want to study the probability of getting a head, p , as a function of N_1 , i.e., for $N_1 = 1, \dots, N$. We also want to vectorize all operations in the code. A first try to compute the probability array for p is

```
import numpy as np
h = np.where(r <= 0.5, 1, 0)
p = np.zeros(N)
for i in range(N):
    p[i] = np.sum(h[:i+1])/float(i+1)
```

An array `q[i] = np.sum(h[:i])` reflects a *cumulative sum* and can be efficiently generated by `np.cumsum: q = np.cumsum(h)`. Thereafter we can compute `p` by `q/I`, where `I[i]=i+1` and `I` can be computed by `np.arange(1,N+1)` or `r_[1:N+1]` (integers 1, 2, ..., up to but not including `N+1`). Implement both the loop over `i` and the vectorized version based on `cumsum` and check in the program that the resulting `p` array has the same elements (for this purpose you have to compare `float` elements and you can use the `float_eq` function from SciTools, see Exercise 2.24, or the `allclose` function in `numpy` (`float_eq` actually uses `allclose` for array arguments)). Plot `p` against `I` for the case where $N = 10000$. Annotate the axis and the plot with relevant text. Name of program file: `flip_coin_prob_developm.py`. \diamond

Exercise 8.25. *Simulate the problems in Exer. 4.25.*

Exercise 4.25 describes some problems that can be solved exactly using the formula (4.8), but we can also simulate these problems and find approximate numbers for the probabilities. That is the task of this exercise.

Make a general function `simulate_binomial(p, n, x)` for running n experiments, where each experiment have two outcomes, with probabilities p and $1 - p$. The n experiments constitute a “success” if the outcome with probability p occurs exactly x times. The `simulate_binomial` function must repeat the n experiments N times. If M is the number of “successes” in the N experiments, the probability estimate is M/N . Let the function return this probability estimate together with the error (the exact result is (4.8)). Simulate the three cases in Exercise 4.25 using this function. Name of program file: `simulate_binomial.py`. \diamond

Exercise 8.26. *Simulate a poker game.*

Make a program for simulating the development of a poker (or simplified poker) game among n players. Use ideas from Chapter 8.2.4. Name of program file: `poker.py`. \diamond

Exercise 8.27. *Write a non-vectorized version of a code.*

Read the file `birth_policy.py` containing the code from Chapter 8.3.5. To prove that you understand what is going on in this simulation, replace all the vectorized code by explicit loops over the random arrays. For such code it is natural to use Python's standard `random` module instead of `numpy.random`. However, to verify your alternative implementation it is important to have the same sequence of random numbers in the two programs. To this end, use `numpy.random`, but draw a single number at a time. Name of program file: `birth_policy2.py`. \diamond

Exercise 8.28. *Estimate growth in a simulation model.*

The simulation model in Chapter 8.3.5 predicts the number of individuals from generation to generation. Make a simulation of the “one son” policy with 10 generations, a male portion of 0.51 among newborn babies, set the fertility to 0.92, and assume that 6% of the population will break the law and want 6 children in a family. These parameters implies a significant growth of the population. See if you can find a factor r such that the number of individuals in generation n fulfills the difference equation

$$x_n = (1 + r)x_{n-1}.$$

Hint: Compute r for two consecutive generations x_{n-1} and x_n ($r = x_n/x_{n-1} - 1$) and see if r is approximately constant as n increases. Name of program file: `estimate_growth.py`. \diamond

Exercise 8.29. *Investigate guessing strategies for Ch. 8.4.1.*

In the game from Chapter 8.4.1 it is smart to use the feedback from the program to track an interval $[p, q]$ that must contain the secret number. Start with $p = 1$ and $q = 100$. If the user guesses at some number n , update p to $n + 1$ if n is less than the secret number (no need to care about numbers smaller than $n + 1$), or update q to $n - 1$ if n is larger than the secret number (no need to care about numbers larger than $n - 1$).

Are there any smart strategies to pick a new guess $s \in [p, q]$? To answer this question, investigate two possible strategies: s as the midpoint in the interval $[p, q]$, or s as a uniformly distributed random integer in $[p, q]$. Make a program that implements both strategies, i.e., the player is not prompted for a guess but the computer computes the guess based on the chosen strategy. Let the program run a large number of games and see if either of the strategies can be considered as superior in the long run. Name of program file: `strategies4guess.py`. \diamond

Exercise 8.30. *Make a vectorized solution to Exer. 8.8.*

Vectorize the simulation program from Exercise 8.8 with the aid of the module `numpy.random` and the `numpy.sum` function. Name of program file: `sum9_4dice_vec.py`. \diamond

Exercise 8.31. *Compute π by a Monte Carlo method.*

Use the method in Chapter 8.5.2 to compute π by computing the area of a circle. Choose G as the circle with its center at the origin and with unit radius, and choose B as the rectangle $[-1, 1] \times [-1, 1]$. A point (x, y) lies within G if $x^2 + y^2 < 1$. Compare the approximate π with `math.pi`. Name of program file: `MC_pi.py`. \diamond

Exercise 8.32. *Implement a variant of Exer. 8.31.*

This exercise has the same purpose of computing π as in Exercise 8.31, but this time you should choose G as a circle with center at $(2, 1)$ and radius 4. Select an appropriate rectangle B . A point (x, y) lies within a circle with center at (x_c, y_c) and with radius R if $(x - x_c)^2 + (y - y_c)^2 < R^2$. Name of program file: `MC_pi2.py`. \diamond

Exercise 8.33. *Compute π by a random sum.*

Let x_0, \dots, x_N be $N + 1$ uniformly distributed random numbers between 0 and 1. Explain why the random sum $S_N = (N + 1)^{-1} \times \sum_{i=0}^N 2(1 - x_i^2)^{-1/2}$ is an approximation to π . (Hint: Interpret the sum as Monte Carlo integration and compute the corresponding integral exactly by hand.) Make a program for plotting S_N versus N for $N = 10^k$, $k = 0, 1/2, 1, 3/2, 2, 5/2, \dots, 6$. Write out the difference between S_{10^6} and `pi` from the `math` module. Name of program file: `MC_pi_plot.py`. \diamond

Exercise 8.34. *1D random walk with drift.*

Modify the `walk1D.py` program such that the probability of going to the right is r and the probability of going to the left is $1 - r$ (draw numbers in $[0, 1)$ rather than integers in $\{1, 2\}$). Compute the average position of n_p particles after 100 steps, where n_p is read from the command line. Mathematically one can show that the average position approaches $rn_s - (1 - r)n_s$ as $n_p \rightarrow \infty$. Write out this exact result together with the computed mean position with a finite number of particles. Name of program file: `walk1D_drift.py`. \diamond

Exercise 8.35. *1D random walk until a point is hit.*

Set `np=1` in the `walk1Dv.py` program and modify the program to measure how many steps it takes for one particle to reach a given point $x = x_p$. Give x_p on the command line. Report results for $x_p = 5, 50, 5000, 50000$. Name of program file: `walk1Dv_hit_point.py`. \diamond

Exercise 8.36. *Simulate making a fortune from gaming.*

A man plays a game where the probability of winning is p and that of losing is consequently $1 - p$. When winning he earns 1 euro and when losing he loses 1 euro. Let x_i be the man's fortune from playing this game i number of times. The starting fortune is x_0 . We assume that the man gets a necessary loan if $x_i < 0$ such that the gaming can continue. The target is a fortune F , meaning that the playing stops when $x = F$ is reached.

Explain why x_i is a 1D random walk. Modify one of the 1D random walk programs to simulate the average number of games it takes to reach the target fortune $x = F$. This average must be computed by running a large number of random walks that start at x_0 and reach F . Use $x_0 = 10$, $F = 100$, and $p = 0.49$ as example.

Suppose the average number of games to reach $x = F$ is proportional to $(F - x_0)^r$, where r is some exponent. Try to find r by experimenting with the program. The r value indicates how difficult it is to make a substantial fortune by playing this game. Note that the *expected* earning is negative when $p < 0.5$, but there is still a small probability for hitting $x = F$. Name of program file: `game_as_walk1D.py`. \diamond

Exercise 8.37. *Make a class for 2D random walk.*

The purpose of this exercise is to reimplement the `walk2D.py` program from Chapter 8.7.1 with the aid of classes. Make a class `Particle` with the coordinates (x, y) and the time step number of a particle as attributes. A method `move` moves the particle in one of the four directions and updates the (x, y) coordinates. Another class, `Particles`, holds a list of `Particle` objects and a `plotstep` parameter (as in `walk2D.py`). A method `move` moves all the particles one step, a method `plot` can make a plot of all particles, while a method `moves` performs a loop over time steps and calls `move` and `plot` in each step.

Equip the `Particle` and `Particles` classes with print functionality such that one can print out all particles in a nice way by saying `print p` (for a `Particles` instance `p`) or `print self` (inside a method). Hint: In `__str__`, apply the `pformat` function from the `pprint` module to the list of particles, and make sure that `__repr__` just reuse `__str__` in both classes.

To verify the implementation, print the first three positions of four particles in the `walk2D.py` program and compare with the corresponding results produced by the class-based implementation (the seed of the random number generator must of course be fixed identically in the two programs). You can just perform `p.move()` and `print p` three times in a `verify` function to do this verification task.

Organize the complete code as a module such that the classes `Particle` and `Particles` can be reused in other programs. The test block should call a `run(N)` method to run the walk for N steps, where N is given on the command line.

Compare the efficiency of the class version against the vectorized version in `walk2Dv.py`, using the techniques of Appendix H.6.1. Name of program file: `walk2Dc.py`. \diamond

Exercise 8.38. *Vectorize the class code from Exer. 8.37.*

The program developed in Exercise 8.37 cannot be vectorized as long as we base the implementation on class `Particle`. However, if we remove that class and focus on class `Particles`, the latter can employ

arrays for holding the positions of all particles and vectorized updates of these positions in the `moves` method. Use ideas from the `walk2Dv.py` program to vectorize class `Particle`. Verify the code against `walk2Dv.py` as explained in Exercise 8.37, and measure the efficiency gain over the version with class `Particle`. Name of program file: `walk2Dcv.py`. \diamond

Exercise 8.39. *2D random walk with walls; scalar version.*

Modify the `walk2D.py` or `walk2Dc.py` programs from Exercise 8.37 so that the walkers cannot walk outside a rectangular area $A = [x_L, x_H] \times [y_L, y_H]$. Do not move the particle if its new position is outside A . Name of program file: `walk2D_barrier.py`. \diamond

Exercise 8.40. *2D random walk with walls; vectorized version.*

Modify the `walk2Dv.py` program so that the walkers cannot walk outside a rectangular area $A = [x_L, x_H] \times [y_L, y_H]$. Hint: First perform the moves of one direction. Then test if new positions are outside A . Such a test returns a boolean array that can be used as index in the position arrays to pick out the indices of the particles that have moved outside A and move them back to the relevant boundary of A . Name of program file: `walk2Dv_barrier.py`. \diamond

Exercise 8.41. *Simulate the mixture of gas molecules.*

Suppose we have a box with a wall dividing the box into two equally sized parts. In one part we have a gas where the molecules are uniformly distributed in a random fashion. At $t = 0$ we remove the wall. The gas molecules will now move around and eventually fill the whole box.

This physical process can be simulated by a 2D random walk inside a fixed area A as introduced in Exercises 8.39 and 8.40 (in reality the motion is three-dimensional, but we only simulate the two-dimensional part of it since we already have programs for doing this). Use the program from either Exercises 8.39 or 8.40 to simulate the process for $A = [0, 1] \times [0, 1]$. Initially, place 10000 particles at uniformly distributed random positions in $[0, 1/2] \times [0, 1]$. Then start the random walk and visualize what happens. Simulate for a long time and make a hardcopy of the animation (an animated GIF file, for instance). Is the end result what you would expect? Name of program file: `disorder1.py`.

Molecules tend to move randomly because of collisions and forces between molecules. We do not model collisions between particles in the random walk, but the nature of this walk, with random movements, simulates the effect of collisions. Therefore, the random walk can be used to model molecular motion in many simple cases. In particular, the random walk can be used to investigate how a quite ordered system, where one gas fills one half of a box, evolves through time to a more disordered system. \diamond

Exercise 8.42. *Solve a variant of Exer. 8.41.*

Solve Exercise 8.41 when the wall dividing the box is not completely removed, but instead we make a small hole in the wall initially. Name of program file: `disorder2.py`. \diamond

Exercise 8.43. *Guess beer brands.*

You are presented n glasses of beer, each containing a different brand. You are informed that there are $m \geq n$ possible brands in total, and the names of all brands are given. For each glass, you can pay p euros to taste the beer, and if you guess the right brand, you get $q \geq p$ euros back. Suppose you have done this before and experienced that you typically manage to guess the right brand T times out of 100, so that your probability of guessing the right brand is $b = T/100$.

Make a function `simulate(m, n, p, q, b)` for simulating the beer tasting process. Let the function return the amount of money earned and how many correct guesses ($\leq n$) you made. Call `simulate` a large number of times and compute the average earnings and the probability of getting full score in the case $m = n = 4$, $p = 3$, $q = 6$, and $b = 1/m$ (i.e., four glasses with four brands, completely random guessing, and a payback of twice as much as the cost). How much more can you earn from this game if your ability to guess the right brand is better, say $b = 1/2$? Name of program file: `simulate_beer_tasting.py`. \diamond

Exercise 8.44. *Simulate stock prices.*

A common mathematical model for the evolution of stock prices can be formulated as a difference equation

$$x_n = x_{n-1} + \Delta t \mu x_{n-1} + \sigma x_{n-1} \sqrt{\Delta t} r_{n-1}, \quad (8.16)$$

where x_n is the stock price at time t_n , Δt is the time interval between two time levels ($\Delta t = t_n - t_{n-1}$), μ is the growth rate of the stock price, σ is the volatility of the stock price, and r_0, \dots, r_{n-1} are normally distributed random numbers with mean zero and unit standard deviation. An initial stock price x_0 must be prescribed together with the input data μ , σ , and Δt .

We can make a remark that Equation (8.16) is a Forward Euler discretization of a stochastic differential equation for $x(t)$:

$$\frac{dx}{dt} = \mu x + \sigma N(t),$$

where $N(t)$ is a so-called white noise random time series signal. Such equations play a central role in modeling of stock prices.

Make R realizations of (8.16) for $n = 0, \dots, N$ for $N = 5000$ steps over a time period of $T = 180$ days with a step size $\Delta t = T/N$. Name of program file: `stock_prices.py`. \diamond

Exercise 8.45. *Compute with option prices in finance.*

In this exercise we are going to consider the pricing of so-called Asian options. An Asian option is a financial contract where the owner earns money when certain market conditions are satisfied.

The contract is specified by a *strike price* K and a maturity time T . It is written on the average price of the underlying stock, and if this average is bigger than the strike K , the owner of the option will earn the difference. If, on the other hand, the average becomes less, the owner receives nothing, and the option matures in the value zero. The average is calculated from the last trading price of the stock for each day.

From the theory of options in finance, the price of the Asian option will be the expected present value of the payoff. We assume the stock price dynamics given as,

$$S(t+1) = (1+r)S(t) + \sigma S(t)\epsilon(t), \quad (8.17)$$

where r is the interest-rate, and σ is the volatility of the stock price. The time t is supposed to be measured in days, $t = 0, 1, 2, \dots$, while $\epsilon(t)$ are independent identically distributed normal random variables with mean zero and unit standard deviation. To find the option price, we must calculate the expectation

$$p = (1+r)^{-T} \mathbb{E} \left[\max \left(\frac{1}{T} \sum_{t=1}^T S(t) - K, 0 \right) \right]. \quad (8.18)$$

The price is thus given as the expected discounted payoff. We will use Monte Carlo simulations to estimate the expectation. Typically, r and σ can be set to $r = 0.0002$ and $\sigma = 0.015$. Assume further $S(0) = 100$.

- Make a function that simulates a path of $S(t)$, that is, the function computes $S(t)$ for $t = 1, \dots, T$ for a given T based on the recursive definition in (8.17). The function should return the path as an array.
- Create a function that finds the average of $S(t)$ from $t = 1$ to $t = T$. Make another function that calculates the price of the Asian option based on N simulated averages. You may choose $T = 100$ days and $K = 102$.
- Plot the price p as a function of N . You may start with $N = 1000$.
- Plot the error in the price estimation as a function N (assume that the p value corresponding to the largest N value is the “right” price). Try to fit a curve of the form c/\sqrt{N} for some c to this error plot. The purpose is to show that the error is reduced as $1/\sqrt{N}$.

Name of program file: `option_price.py`.

If you wonder where the values for r and σ come from, you will find the explanation in the following. A reasonable level for the yearly interest-rate is around 5%, which corresponds to a daily rate

$0.05/250 = 0.0002$. The number 250 is chosen because a stock exchange is on average open this amount of days for trading. The value for σ is calculated as the volatility of the stock price, corresponding to the standard deviation of the daily returns of the stock defined as $(S(t+1) - S(t))/S(t)$. “Normally”, the volatility is around 1.5% a day. Finally, there are theoretical reasons why we assume that the stock price dynamics is driven by r , meaning that we consider the *risk-neutral* dynamics of the stock price when pricing options. There is an exciting theory explaining the appearance of r in the dynamics of the stock price. If we want to simulate a stock price dynamics mimicing what we see in the market, r in Equation (8.17) must be substituted with μ , the expected return of the stock. Usually, μ is higher than r . \diamond

Exercise 8.46. *Compute velocity and acceleration.*

In a laboratory experiment waves are generated through the impact of a model slide into a wave tank. (The intention of the experiment is to model a future tsunami event in a fjord, generated by loose rocks that fall into the fjord.) At a certain location, the elevation of the surface, denoted by η , is measured at discrete points in time using an ultra-sound wave gauge. The result is a time series of vertical positions of the water surface elevations in meter: $\eta(t_0), \eta(t_1), \eta(t_2), \dots, \eta(t_n)$. There are 300 observations per second, meaning that the time difference between two neighboring measurement values $\eta(t_i)$ and $\eta(t_{i+1})$ is $h = 1/300$ second.

Write a Python program that accomplishes the following tasks:

1. Read h from the command line.
2. Read the η values in the file `src/random/gauge.dat` into an array `eta`.
3. Plot `eta` versus the time values.
4. Compute the velocity v of the surface by the formula

$$v_i \approx \frac{\eta_{i+1} - \eta_{i-1}}{2h}, \quad i = 1, \dots, n-1.$$

Plot v versus time values in a separate plot.

5. Compute the acceleration a of the surface by the formula

$$a_i \approx \frac{\eta_{i+1} - 2\eta_i + \eta_{i-1}}{h^2}, \quad i = 1, \dots, n-1.$$

Plot a versus the time values in a separate plot.

Name of program file: `labstunami1.py`. \diamond

Exercise 8.47. *Differentiate noisy signals.*

The purpose of this exercise is to look into numerical differentiation of time series signals that contain measurement errors. This insight might be helpful when analyzing the noise in real data from a laboratory experiment in Exercises 8.46 and 8.48.

1. Compute a signal

$$\bar{\eta}_i = A \sin\left(\frac{2\pi}{T}t_i\right), \quad t_i = i\frac{T}{40}, \quad i = 0, \dots, 200.$$

Display $\bar{\eta}_i$ versus time t_i in a plot. Choose $A = 1$ and $T = 2\pi$. Store the $\bar{\eta}$ values in an array `etabar`.

2. Compute a signal with random noise E_i ,

$$\eta_i = \bar{\eta}_i + E_i,$$

E_i is drawn from the normal distribution with mean zero and standard deviation $\sigma = 0.04A$. Plot this η_i signal as circles in the same plot as $\bar{\eta}_i$. Store the E_i in an array `E` for later use.

3. Compute the first derivative of $\bar{\eta}_i$ by the formula

$$\frac{\bar{\eta}_{i+1} - \bar{\eta}_{i-1}}{2h}, \quad i = 1, \dots, n-1,$$

and store the values in an array `detabar`. Display the graph.

4. Compute the first derivative of the error term by the formula

$$\frac{E_{i+1} - E_{i-1}}{2h}, \quad i = 1, \dots, n-1,$$

and store the values in an array `dE`. Calculate the mean and the standard deviation of `dE`.

5. Plot `detabar` and `detabar + dE`. Use the result of the standard deviation calculations to explain the qualitative features of the graphs.
6. The second derivative of a time signal η_i can be computed by

$$\frac{\eta_{i+1} - 2\eta_i + \eta_{i-1}}{h^2}, \quad i = 1, \dots, n-1.$$

Use this formula on the `etabar` data and save the result in `d2etabar`. Also apply the formula to the `E` data and save the result in `d2E`. Plot `d2etabar` and `d2etabar + d2E`. Compute the standard deviation of `d2E` and compare with the standard deviation of `dE` and `E`. Discuss the plot in light of these standard deviations.

Name of program file: `sine_noise.py`. ◇

Exercise 8.48. *Model the noise in the data in Exer. 8.47.*

We assume that the measured data can be modeled as a smooth time signal $\bar{\eta}(t)$ plus a random variation $E(t)$. Computing the velocity of $\eta = \bar{\eta} + E$ results in a smooth velocity from the $\bar{\eta}$ term and a noisy signal from the E term. We can estimate the level of noise in the first derivative of E as follows. The random numbers $E(t_i)$ are assumed to be independent and normally distributed with mean zero and standard deviation σ . It can then be shown that

$$\frac{E_{i+1} - E_{i-1}}{2h}$$

produces numbers that come from a normal distribution with mean zero and standard deviation $2^{-1/2}h^{-1}\sigma$. How much is the original noise, reflected by σ , magnified when we use this numerical approximation of the velocity?

The fraction

$$\frac{E_{i+1} - 2E_i + E_{i-1}}{h^2}$$

will also generate numbers from a normal distribution with mean zero, but this time with standard deviation $2h^{-2}\sigma$. Find out how much the noise is magnified in the computed acceleration signal.

The numbers in the `gauge.dat` file are given with 5 digits. This is no certain indication of the accuracy of the measurements, but as a test we may assume σ is of the order 10^{-4} . Check if the visual results for the velocity and acceleration are consistent with the standard deviation of the noise in these signals as modeled above. \diamond

Exercise 8.49. *Reduce the noise in Exer. 8.47.*

If we have a noisy signal η_i , where $i = 0, \dots, n$ counts time levels, the noise can be reduced by computing a new signal where the value at a point is a weighted average of the values at that point and the neighboring points at each side. More precisely, given the signal η_i , $i = 0, \dots, n$, we compute a filtered (averaged) signal with values $\eta_i^{(1)}$ by the formula

$$\eta_i^{(1)} = \frac{1}{4}(\eta_{i+1} + 2\eta_i + \eta_{i-1}), \quad i = 1, \dots, n-1, \quad \eta_0^{(1)} = \eta_0, \quad \eta_n^{(1)} = \eta_n. \quad (8.19)$$

Make a function `filter` that takes the η_i values in an array `eta` as input and returns the filtered $\eta_i^{(1)}$ values in an array. Let $\eta_i^{(k)}$ be the signal arising by applying the `filtered` function k times to the same signal. Make a plot with curves η_i and the filtered $\eta_i^{(k)}$ values for $k = 1, 10, 100$. Make similar plots for the velocity and acceleration where these are made from both the original η data and the filtered data. Discuss the results. Name of program file: `labstunami2.py`. \diamond

Exercise 8.50. *Make a class for differentiating noisy data.*

Suppose you have some time series signal $y(t_k)$ for $k = 0, \dots, n-1$, where $t_k = k\Delta t$ are time points. Differentiating such a signal can give very inaccurate results if the signal contains noise. Exercises 8.46–8.49 explore this topic, and Exercise 8.49 suggests to filter the signal. The purpose of the present exercise is to make a tool for differentiating noisy signals.

Make a class `DiffNoisySignal` where the constructor takes three arguments: the signal $y(t_k)$ (as an array), the order of the desired derivative (as an `int`, either 1 or 2), and the name of the signal (as a string). A method `filter(self, n)` runs the filter from Exercise 8.49 n times on the signal. The method `diff(self)` performs the differentiation and

stores the differentiated signal as an attribute in the class. There should also be some plotting methods: `plot(self)` for plotting the current (original or filtered) signal, `plot_diff(self)` for plotting the differentiated signal, `animate_filter` for animating the effect of filtering (run `filter` once per frame in the movie), and `animate_diff` for animating the evolution of the derivative when `filter` and `diff` are called once each per frame.

Implement the class and test it on the noisy signal

$$y(t_k) = \cos(2\pi t_k) + 0.1r_k, \quad t_k = k\Delta t, \quad k = 0, \dots, n-1,$$

with $\Delta t = 1/60$. The quantities r_k are random numbers in $[0, 1)$. Make animations with the `animate_filter` and `animate_diff` methods. Name of program file: `DiffNoisySignal.py`. \diamond

Exercise 8.51. *Speed up Markov chain mutation.*

The functions `transition` and `mutate_via_markov_chain` from Chapter 8.3.4 were made for being easy to read and understand. Upon closer inspection, we realize that the `transition` function constructs the `interval_limits` every time a random transition is to be computed, and we want to run a large number of transitions. By (i) merging the two functions, (ii) pre-computing interval limits for each `from_base`, and (iii) adding a loop over `N` mutations, one can reduce the computation of interval limits to a minimum. Perform such an efficiency enhancement. Measure the CPU time of this new function versus the `mutate_via_markov_chain` function for 1 million mutations. Name of program file: `markov_chain_mutation2.py`. \diamond

This chapter introduces the basic ideas of object-oriented programming. Different people put different meanings into the term object-oriented programming: Some use the term for programming with objects in general, while others use the term for programming with class hierarchies. The author applies the second meaning, which is the most widely accepted one in computer science. The first meaning is better named *object-based* programming. Since everything in Python is an object, we do object-based programming all the time, yet one usually reserves this term for the case when classes different from Python's basic types (`int`, `float`, `str`, `list`, `tuple`, `dict`) are involved.

A necessary background for the present chapter is Chapter 7. For Chapters 9.2 and 9.3 one must know basic methods for numerical differentiation and integration, for example from Appendix B. During an initial readings of the chapter, it can be beneficial to skip the more advanced material in Chapters 9.2.3–9.2.6.

All the programs associated with this chapter are found in the `src/oo` folder.

9.1 Inheritance and Class Hierarchies

Most of this chapter tells you how to put related classes together in families such that the family can be viewed as one unit. This idea helps to hide details in a program, and makes it easier to modify or extend the program.

A family of classes is known as a *class hierarchy*. As in a biological family, there are parent classes and child classes. Child classes can *inherit* data and methods from parent classes, they can modify these data and methods, and they can add their own data and methods. This means that if we have a class with some functionality, we can extend

this class by creating a child class and simply add the functionality we need. The original class is still available and the separate child class is small, since it does not need to repeat the code in the parent class.

The magic of object-oriented programming is that other parts of the code do not need to distinguish whether an object is the parent or the child – all generations in a family tree can be treated as a unified object. In other words, one piece of code can work with all members in a class family or hierarchy. This principle has revolutionized the development of large computer systems¹.

The concepts of classes and object-oriented programming first appeared in the Simula programming language in the 1960s. Simula was invented by the Norwegian computer scientists Ole-Johan Dahl and Kristen Nygaard, and the impact of the language is particularly evident in C++, Java, and C#, three of the most dominating programming languages in the world today. The invention of object-oriented programming was a remarkable achievement, and the professors Dahl and Nygaard received two very prestigious prizes: the von Neumann medal and the Turing prize (popularly known as the Nobel prize of computer science).

A parent class is usually called *base class* or *superclass*, while the child class is known as a *subclass* or *derived class*. We shall use the terms superclass and subclass from now on.

9.1.1 A Class for Straight Lines

Assume that we have written a class for straight lines, $y = c_0 + c_1x$:

```
class Line:
    def __init__(self, c0, c1):
        self.c0 = c0
        self.c1 = c1

    def __call__(self, x):
        return self.c0 + self.c1*x

    def table(self, L, R, n):
        """Return a table with n points for L <= x <= R."""
        s = ''
        import numpy as np
        for x in np.linspace(L, R, n):
            y = self(x)
            s += '%12g %12g\n' % (x, y)
        return s
```

The constructor `__init__` initializes the coefficients c_0 and c_1 in the expression for the straight line: $y = c_0 + c_1x$. The call operator `__call__` evaluates the function $c_1x + c_0$, while the `table` method samples the function at n points and creates a table of x and y values.

¹ Two of the most widely used computer languages today are Java and C#. Both of them force programs to be written in an object-oriented style.

9.1.2 A First Try on a Class for Parabolas

A parabola $y = c_0 + c_1x + c_2x^2$ contains a straight line as a special case ($c_2 = 0$). A class for parabolas will therefore be similar to a class for straight lines. All we have to do is to add the new term c_2x^2 in the function evaluation and store c_2 in the constructor:

```
class Parabola:
    def __init__(self, c0, c1, c2):
        self.c0 = c0
        self.c1 = c1
        self.c2 = c2

    def __call__(self, x):
        return self.c2*x**2 + self.c1*x + self.c0

    def table(self, L, R, n):
        """Return a table with n points for L <= x <= R."""
        s = ''
        import numpy as np
        for x in np.linspace(L, R, n):
            y = self(x)
            s += '%12g %12g\n' % (x, y)
        return s
```

Observe that we can copy the `table` method from class `Line` without any modifications.

9.1.3 A Class for Parabolas Using Inheritance

Python and other languages that support object-oriented programming have a special construct, so that class `Parabola` does not need to repeat the code that we have already written in class `Line`. We can specify that class `Parabola` *inherits* all code from class `Line` by adding “(Line)” in the class headline:

```
class Parabola(Line):
```

Class `Parabola` now automatically gets all the code from class `Line` – invisibly. Exercise 9.1 asks you to explicitly demonstrate the validity of this assertion. We say that class `Parabola` is *derived* from class `Line`, or equivalently, that class `Parabola` is a subclass of its superclass `Line`.

Now, class `Parabola` should not be identical to class `Line`: it needs to add data in the constructor (for the new term) and to modify the call operator (because of the new term), but the `table` method can be inherited as it is. If we implement the constructor and the call operator in class `Parabola`, these will *override* the inherited versions from class `Line`. If we do not implement a `table` method, the one inherited from class `Line` is available as if it were coded visibly in class `Parabola`.

Class `Parabola` must first have the statements from the class `Line` methods `__call__` and `__init__`, and then add extra code in these methods. An important principle in computer programming is to avoid

repeating code. We should therefore call up functionality in class `Line` instead of copying statements from class `Line` methods to `Parabola` methods. Any method in the superclass `Line` can be called using the syntax

```
Line.methodname(self, arg1, arg2, ...)
# or
super(Parabola, self).methodname(arg1, arg2, ...)
```

The latter construction only works if the super class is derived from Python's general super class object (i.e., class `Line` must be a new-style class).

Let us now show how to write class `Parabola` as a subclass of class `Line`, and implement just the new additional code that we need and that is not already written in the superclass:

```
class Parabola(Line):
    def __init__(self, c0, c1, c2):
        Line.__init__(self, c0, c1) # let Line store c0 and c1
        self.c2 = c2

    def __call__(self, x):
        return Line.__call__(self, x) + self.c2*x**2
```

This short implementation of class `Parabola` provides exactly the same functionality as the first version of class `Parabola` that we showed on page 485 and that did not inherit from class `Line`. Figure 9.1 shows the class hierarchy in UML fashion. The arrow from one class to another indicates inheritance.

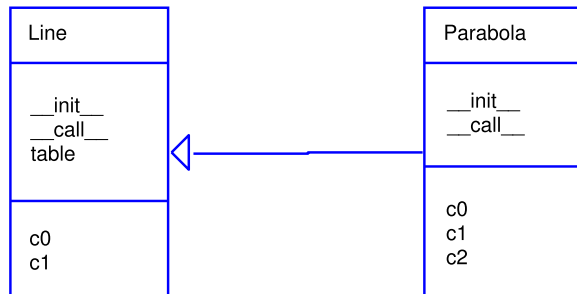

Fig. 9.1 UML diagram for the class hierarchy with superclass `Line` and subclass `Parabola`.

A quick demo of the `Parabola` class in a main program,

```
p = Parabola(1, -2, 2)
p1 = p(x=2.5)
print p1
print p.table(0, 1, 3)
```

gives this output:

```
8.5
      0
    0.5  1
      1      0.5
           1
```

Program Flow. The program flow can be somewhat complicated when we work with class hierarchies. Consider the code segment

```
p = Parabola(1, -1, 2)
p1 = p(x=2.5)
```

Let us explain the program flow in detail for these two statements. As always, you can monitor the program flow in a debugger as explained in Chapter F.1.

Calling `Parabola(1, -1, 2)` leads to a call to the constructor method `__init__`, where the arguments `c0`, `c1`, and `c2` in this case are `int` objects with values 1, -1, and 2. The `self` argument in the constructor is the object that will be returned and referred to by the variable `p`. Inside the constructor in class `Parabola` we call the constructor in class `Line`. In this latter method, we create two attributes in the `self` object. Printing out `dir(self)` will explicitly demonstrate what `self` contains so far in the construction process. Back in class `Parabola`'s constructor, we add a third attribute `c2` to the same `self` object. Then the `self` object is invisibly returned and referred to by `p`.

The other statement, `p1 = p(x=2.5)`, has a similar program flow. First we enter the `p.__call__` method with `self` as `p` and `x` as a `float` object with value 2.5. The program flow jumps to the `__call__` method in class `Line` for evaluating the linear part $c_1x + c_0$ of the expression for the parabola, and then the flow jumps back to the `__call__` method in class `Parabola` where we add the new quadratic term.

9.1.4 Checking the Class Type

Python has the function `isinstance(i,t)` for checking if an instance `i` is of class type `t`:

```
>>> l = Line(-1, 1)
>>> isinstance(l, Line)
True
>>> isinstance(l, Parabola)
False
```

A `Line` is not a `Parabola`, but is a `Parabola` a `Line`?

```
>>> p = Parabola(-1, 0, 10)
>>> isinstance(p, Parabola)
True
>>> isinstance(p, Line)
True
```

Yes, from a class hierarchy perspective, a `Parabola` instance is regarded as a `Line` instance too, since it contains everything that a `Line` instance contains.

Every instance has an attribute `__class__` that holds the type of class:

```
>>> p.__class__
<class __main__.Parabola at 0xb68f108c>
>>> p.__class__ == Parabola
True
>>> p.__class__.__name__ # string version of the class name
'Parabola'
```

Note that `p.__class__` is a class object (or class definition one may say²), while `p.__class__.__name__` is a string. These two variables can be used as an alternative test for the class type:

```
if p.__class__.__name__ == 'Parabola':
    <statements>
# or
if p.__class__ == Parabola:
    <statements>
```

However, `isinstance(p, Parabola)` is the recommended programming style for checking the type of an object.

A function `issubclass(c1, c2)` tests if class `c1` is a subclass of class `c2`, e.g.,

```
>>> issubclass(Parabola, Line)
True
>>> issubclass(Line, Parabola)
False
```

The superclasses of a class are stored as a tuple in the `__bases__` attribute of the class object:

```
>>> p.__class__.__bases__
(<class __main__.Line at 0xb7c5d2fc>,)
>>> p.__class__.__bases__[0].__name__ # extract name as string
'Line'
```

9.1.5 Attribute Versus Inheritance

Instead of letting class `Parabola` inherit from a class `Line`, we may let it *contain* a class `Line` instance as an attribute:

```
class Parabola:
    def __init__(self, c0, c1, c2):
        self.line = Line(c0, c1) # let Line store c0 and c1
        self.c2 = c2

    def __call__(self, x):
        return self.line(x) + self.c2*x**2
```

Whether to use inheritance or an attribute depends on the problem being solved. If it is natural to say that class `Parabola` *is* a `Line` object, we say that `Parabola` has an *is-a relationship* with class `Line`. Alternatively, if it is natural to think that class `Parabola` *has a* `Line`

² This means that even the definition of a class, i.e., the class code, is an object that can be referred to by a variable.

object, we speak about a *has-a relationship* with class `Line`. In the present example, the is-a relationship is more natural since a special case of a parabola is a straight line.

From a mathematical point of view, however, many will say that a parabola *is not* a line, but that a line is a special case of a parabola. Adopting this reasoning reverses the dependency of the classes: now it is more natural to let `Line` is a subclass of `Parabola` (*Line is a Parabola*). This easy, and all we have to do is

```
class Parabola:
    def __init__(self, c0, c1, c2):
        self.c0, self.c1, self.c2 = c0, c2, c2

    def __call__(self, x):
        return self.c0 + self.c1*x + self.c2*x**2

    def table(self, L, R, n): # implemented as shown above

class Line(Parabola):
    def __init__(self, c0, c1):
        Parabola.__init__(self, c0, c1, 0)
```

The inherited `__call__` method from class `Parabola` will work since the `c3` coefficient is zero. Exercises 9.4 suggests deriving `Parabola` from a general class `Polynomial` and asks you to discuss which class design you prefer.

How classes depend on each other is influenced by two factors: sharing of code and logical relations. From a sharing of code perspective, many will say that class `Parabola` is naturally a subclass of `Line`, the former adds code to the latter. On the other hand, `Line` is naturally a subclass of `Parabola` from the logical relations in mathematics. Computational efficiency is a third perspective when we implement mathematics. When `Line` is a subclass of `Parabola` we always evaluate the c_2x^2 term in the parabola although this term is zero. Nevertheless, when `Parabola` is a subclass of `Line`, we call `Line.__call__` to evaluate the linear part of the second-degree polynomial, and this call is costly in Python. From a pure efficiency point of view, we would reprogram the linear part in `Parabola.__call__` (which is against the programming habit we have been arguing for!). This little discussion here highlights the many different considerations that come into play when establishing class relations.

9.1.6 Extending Versus Restricting Functionality

In our example of `Parabola` as a subclass of `Line`, we used inheritance to *extend* the functionality of the superclass. Inheritance can also be used for *restricting* functionality. Say we have class `Parabola`:

```
class Parabola:
    def __init__(self, c0, c1, c2):
        self.c0 = c0
        self.c1 = c1
        self.c2 = c2

    def __call__(self, x):
        return self.c2*x**2 + self.c1*x + self.c0

    def table(self, L, R, n):
        ...
```

We can define `Line` as a subclass of `Parabola` and restrict the functionality:

```
class Line(Parabola):
    def __init__(self, c0, c1):
        Parabola.__init__(self, c0, c1, 0)
```

The `__call__` and `table` methods can be inherited as they are defined in class `Parabola`.

From this example it becomes clear that there is no unique way of arranging classes in hierarchies. Rather than starting with `Line` and introducing `Parabola`, `Cubic`, and perhaps eventually a general `Polynomial` class, we can start with a general `Polynomial` class and let `Parabola` be a subclass which restricts all coefficients except the first three to be zero. Class `Line` can then be a subclass of `Parabola`, restricting the value of one more coefficient. Exercise 9.4 asks you to implement such a class hierarchy, and to discuss what kind of hierarchy design you like best.

9.1.7 Superclass for Defining an Interface

As another example of class hierarchies, we now want to represent functions by classes, as described in Chapter 7.1.2, but in addition to the `__call__` method, we also want to provide methods for the first and second derivative. The class can be sketched as

```
class SomeFunc:
    def __init__(self, parameter1, parameter2, ...)
        # Store parameters
    def __call__(self, x):
        # Evaluate function
    def df(self, x):
        # Evaluate the first derivative
    def ddf(self, x):
        # Evaluate the second derivative
```

For a given function, the analytical expressions for first and second derivative must be manually coded. However, we could think of inheriting general functions for computing these derivatives numerically,

such that the only thing we must always implement is the function itself. To realize this idea, we create a superclass³

```
class FuncWithDerivatives:
    def __init__(self, h=1.0E-5):
        self.h = h # spacing for numerical derivatives

    def __call__(self, x):
        raise NotImplementedError\
        ('__call__ missing in class %s' % self.__class__.__name__)

    def df(self, x):
        """Return the 1st derivative of self.f."""
        # Compute first derivative by a finite difference
        h = self.h
        return (self(x+h) - self(x-h))/(2.0*h)

    def ddf(self, x):
        """Return the 2nd derivative of self.f."""
        # Compute second derivative by a finite difference:
        h = self.h
        return (self(x+h) - 2*self(x) + self(x-h))/(float(h)**2)
```

This class is only meant as a superclass of other classes. For a particular function, say $f(x) = \cos(ax) + x^3$, we represent it by a subclass:

```
class MyFunc(FuncWithDerivatives):
    def __init__(self, a):
        self.a = a

    def __call__(self, x):
        return cos(self.a*x) + x**3

    def df(self, x):
        a = self.a
        return -a*sin(a*x) + 3*x**2

    def ddf(self, x):
        a = self.a
        return -a*a*cos(a*x) + 6*x
```

The superclass constructor is never called, hence `h` is never initialized, and there are no possibilities for using numerical approximations via the superclass methods `df` and `ddf`. Instead, we override all the inherited methods and implement our own versions. Many think it is a good programming style to always call the superclass constructor in a subclass constructor, even in simple classes where we do not need the functionality of the superclass constructor.

For a more complicated function, e.g., $f(x) = \ln |p \tanh(qx \cos rx)|$, we may skip the analytical derivation of the derivatives, and just code $f(x)$ and rely on the difference approximations inherited from the superclass to compute the derivatives:

³ Observe that we carefully ensure that the divisions in methods `df` and `ddf` can never be integer divisions.

```
class MyComplicatedFunc(FuncWithDerivatives):
    def __init__(self, p, q, r, h=1.0E-5):
        FuncWithDerivatives.__init__(self, h)
        self.p, self.q, self.r = p, q, r

    def __call__(self, x):
        return log(abs(self.p*tanh(self.q*x*cos(self.r*x))))
```

That's it! We are now ready to use this class:

```
>>> f = MyComplicatedFunc(1, 1, 1)
>>> x = pi/2
>>> f(x)
-36.880306514638988
>>> f.df(x)
-60.593693618216086
>>> f.ddf(x)
3.3217246931444789e+19
```

Class `MyComplicatedFunc` inherits the `df` and `ddf` methods from the superclass `FuncWithDerivatives`. These methods compute the first and second derivatives approximately, provided that we have defined a `__call__` method. If we fail to define this method, we will inherit `__call__` from the superclass, which just raises an exception, saying that the method is not properly implemented in class `MyComplicatedFunc`.

The important message in this subsection is that we introduced a super class to mainly define an *interface*, i.e., the operations (in terms of methods) that one can do with a class in this class hierarchy. The superclass itself is of no direct use, since it does not implement any function evaluation in the `__call__` method. However, it stores a variable common to all subclasses (`h`), and it implements general methods `df` and `ddf` that any subclass can make use of. A specific mathematical function must be represented as a subclass, where the programmer can decide whether analytical derivatives are to be used, or if the more lazy approach of inheriting general functionality (`df` and `ddf`) for computing numerical derivatives is satisfactory.

In object-oriented programming, the superclass very often defines an interface, and instances of the superclass have no applications on their own – only instances of subclasses can do anything useful.

To digest the present material on inheritance, we recommend to do Exercises 9.1–9.4 before reading the next section.

9.2 Class Hierarchy for Numerical Differentiation

Chapter 7.3.2 presents a class `Derivative` that “can differentiate” any mathematical function represented by a callable Python object. The class employs the simplest possible numerical derivative. There are a lot of other numerical formulas for computing approximations to $f'(x)$:

$$f'(x) = \frac{f(x+h) - f(x)}{h} + \mathcal{O}(h), \quad (\text{1st-order forward diff.}) \quad (9.1)$$

$$f'(x) = \frac{f(x) - f(x-h)}{h} + \mathcal{O}(h), \quad (\text{1st-order backward diff.}) \quad (9.2)$$

$$f'(x) = \frac{f(x+h) - f(x-h)}{2h} + \mathcal{O}(h^2), \quad (\text{2nd-order central diff.}) \quad (9.3)$$

$$f'(x) = \frac{4}{3} \frac{f(x+h) - f(x-h)}{2h} - \frac{1}{3} \frac{f(x+2h) - f(x-2h)}{4h} + \mathcal{O}(h^4),$$

(4th-order central diff.) (9.4)

$$f'(x) = \frac{3}{2} \frac{f(x+h) - f(x-h)}{2h} - \frac{3}{5} \frac{f(x+2h) - f(x-2h)}{4h} +$$

$$\frac{1}{10} \frac{f(x+3h) - f(x-3h)}{6h} + \mathcal{O}(h^6),$$

(6th-order central diff.) (9.5)

$$f'(x) = \frac{1}{h} \left(-\frac{1}{6} f(x+2h) + f(x+h) - \frac{1}{2} f(x) - \frac{1}{3} f(x-h) \right) + \mathcal{O}(h^3),$$

(3rd-order forward diff.) (9.6)

The key ideas about the implementation of such a family of formulas are explained in Chapter 9.2.1. For the interested reader, Chapters 9.2.3–9.2.6 contains more advanced additional material that can well be skipped in a first reading. However, the additional material puts the basic solution in Chapter 9.2.1 into a wider perspective, which may increase the understanding of object orientation.

9.2.1 Classes for Differentiation

It is argued in Chapter 7.3.2 that it is wise to implement a numerical differentiation formula as a class where $f(x)$ and h are attributes and a `__call__` method makes class instances behave as ordinary Python functions. Hence, when we have a collection of different numerical differentiation formulas, like (9.1)–(9.6), it makes sense to implement each one of them as a class.

Doing this implementation (see Exercise 7.13), we realize that the constructors are identical because their task in the present case to store f and h . Object-orientation is now a natural next step: We can avoid duplicating the constructors by letting all the classes inherit the common constructor code. To this end, we introduce a superclass `Diff` and implement the different numerical differentiation rules in subclasses of `Diff`. Since the subclasses inherit their constructor, all they have to do is to provide a `__call__` method that implements the relevant differentiation formula.

Let us show what the superclass `Diff` looks like and how three subclasses implement the formulas (9.1)–(9.3):

```

class Diff:
    def __init__(self, f, h=1E-5):
        self.f = f
        self.h = float(h)

class Forward1(Diff):
    def __call__(self, x):
        f, h = self.f, self.h
        return (f(x+h) - f(x))/h

class Backward1(Diff):
    def __call__(self, x):
        f, h = self.f, self.h
        return (f(x) - f(x-h))/h

class Central2(Diff):
    def __call__(self, x):
        f, h = self.f, self.h
        return (f(x+h) - f(x-h))/(2*h)

```

These small classes demonstrates an important feature of object-orientation: code common to many different classes are placed in a superclass, and the subclasses add just the code that differs among the classes.

We can easily implement the formulas (9.4)–(9.6) by following the same method:

```

class Central4(Diff):
    def __call__(self, x):
        f, h = self.f, self.h
        return (4./3)*(f(x+h) - f(x-h)) / (2*h) - \
            (1./3)*(f(x+2*h) - f(x-2*h)) / (4*h)

class Central6(Diff):
    def __call__(self, x):
        f, h = self.f, self.h
        return (3./2)*(f(x+h) - f(x-h)) / (2*h) - \
            (3./5)*(f(x+2*h) - f(x-2*h)) / (4*h) + \
            (1./10)*(f(x+3*h) - f(x-3*h)) / (6*h)

class Forward3(Diff):
    def __call__(self, x):
        f, h = self.f, self.h
        return (-(1./6)*f(x+2*h) + f(x+h) - 0.5*f(x) - \
            (1./3)*f(x-h))/h

```

Here is a short example of using one of these classes to numerically differentiate the sine function⁴:

```

>>> from Diff import *
>>> from math import sin
>>> mycos = Central4(sin)
>>> mycos(pi) # compute sin'(pi)
-1.000000082740371

```

⁴ We have placed all the classes in the file `Diff.py` such that these classes constitute a module. In an interactive session or a small program, we must import the differentiation classes from the `Diff` module.

Instead of a plain Python function we may use an object with a `__call__` method, here exemplified through the function $f(t; a, b, c) = at^2 + bt + c$:

```
class Poly2:
    def __init__(self, a, b, c):
        self.a, self.b, self.c = a, b, c
    def __call__(self, t):
        return self.a*t**2 + self.b*t + self.c

f = Poly2(1, 0, 1)
dfdt = Central4(f)
t = 2
print "f'(%g)=%g" % (t, dfdt(t))
```

Let us examine the program flow. When Python encounters `dfdt = Central4(f)`, it looks for the constructor in class `Central4`, but there is no constructor in that class. Python then examines the superclasses of `Central4`, listed in `Central4.__bases__`. The superclass `Diff` contains a constructor, and this method is called. When Python meets the `dfdt(t)` call, it looks for `__call__` in class `Central4` and finds it, so there is no need to examine the superclass. This process of looking up methods of a class is called *dynamic binding*.

Computer Science Remark. Dynamic binding means that a name is bound to a function while the program is running. Normally, in computer languages, a function name is static in the sense that it is hard-coded as part of the function body and will not change during the execution of the program. This principle is known as static binding of function/method names. Object orientation offers the technical means to associate different functions with the same name, which yields a kind of magic for increased flexibility in programs. The particular function that the name refers to can be set at run-time, i.e., when the program is running, and therefore known as dynamic binding.

In Python, dynamic binding is a natural feature since names (variables) can refer to functions and therefore be dynamically bound during execution, just as any ordinary variable. To illustrate this point, let `func1` and `func2` be two Python functions of one argument, and consider the code

```
if input == 'func1':
    f = func1
elif input == 'func2':
    f = func2
y = f(x)
```

Here, the name `f` is bound to one of the `func1` and `func2` function objects while the program is running. This is a result of two features: (i) dynamic typing (so the contents of `f` can change), and (ii) functions being ordinary objects. The bottom line is that dynamic binding comes natural in Python, while it appears more like convenient magic in languages like C++, Java, and C#.

9.2.2 A Flexible Main Program

As a demonstration of the power of Python programming, we shall now write a program that accepts a function on the command-line, together with information about the difference type (centered, backward, or forward), the order of the approximation, and a value of the independent variable. The output from the program is the derivative of the given function. An example of the usage of the program goes like this:

Terminal

```
differentiate.py 'exp(sin(x))' Central 2 3.1
-1.04155573055
```

Here, we asked the program to differentiate $f(x) = e^{\sin x}$ at $x = 3.1$ with a central scheme of order 2 (using the `Central2` class in the `Diff` hierarchy).

We can provide any expression with `x` as input and request any scheme from the `Diff` hierarchy, and the derivative will be (approximately) computed. One great thing with Python is that the code is very short:

```
import sys
from Diff import *
from math import *
from scitools.StringFunction import StringFunction

formula = sys.argv[1]
f = StringFunction(formula)
difftype = sys.argv[2]
difforder = sys.argv[3]
classname = difftype + difforder
df = eval(classname + '(f)')
x = float(sys.argv[4])
print df(x)
```

Read the code line by line, and convince yourself that you understand what is going on. You may need to review Chapters 4.1.2 and 4.1.4.

One disadvantage is that the code above is limited to `x` as the name of the independent variable. If we allow a 5th command-line argument with the name of the independent variable, we can pass this name on to the `StringFunction` constructor, and suddenly our program works with any name for the independent variable!

```
varname = sys.argv[5]
f = StringFunction(formula, independent_variables=varname)
```

Of course, the program crashes if we do not provide five command-line arguments, and the program does not work properly if we are not careful with ordering of the command-line arguments. There is some way to go before the program is really user friendly, but that is beyond the scope of this chapter.

There are two strengths of the `differentiate.py` program: i) interactive specification of the function and the differentiation method, and

ii) identical syntax for calling any differentiation method. With one line we create the subclass instance based on input strings. Many other popular programming languages (C++, Java, C#) cannot perform the `eval` operation while the program is running. The result is that we need `if` tests to turn the input string information into creation of subclass instances. Such type of code would look like this in Python:

```
if classname == 'Forward1':
    df = Forward1(f)
elif classname == 'Backward1':
    df = Backward1(f)
...
```

and so forth. This piece of code is very common in object-oriented systems and often put in a function that is referred to as a *factory function*. Factory functions can be made very compact in Python thanks to `eval`.

9.2.3 Extensions

The great advantage of sharing code via inheritance becomes obvious when we want to extend the functionality of a class hierarchy. It is possible to do this by adding more code to the superclass only. Suppose we want to be able to assess the accuracy of the numerical approximation to the derivative by comparing with the exact derivative, if available. All we need to do is to allow an extra argument in the constructor and provide an additional superclass method that computes the error in the numerical derivative. We may add this code to class `Diff`, or we may add it in a subclass `Diff2` and let the other classes for various numerical differentiation formulas inherit from class `Diff2`. We follow the latter approach:

```
class Diff2(Diff):
    def __init__(self, f, h=1E-5, dfdx_exact=None):
        Diff.__init__(self, f, h)
        self.exact = dfdx_exact

    def error(self, x):
        if self.exact is not None:
            df_numerical = self(x)
            df_exact = self.exact(x)
            return df_exact - df_numerical

class Forward1(Diff2):
    def __call__(self, x):
        f, h = self.f, self.h
        return (f(x+h) - f(x))/h
```

The other subclasses, `Backward1`, `Central2`, and so on, must also be derived from `Diff2` to equip all subclasses with new functionality for perfectly assessing the accuracy of the approximation. No other modifications are necessary in this example, since all the subclasses can inherit the superclass constructor and the `error` method. Figure 9.2 shows a UML diagram of the new `Diff` class hierarchy.

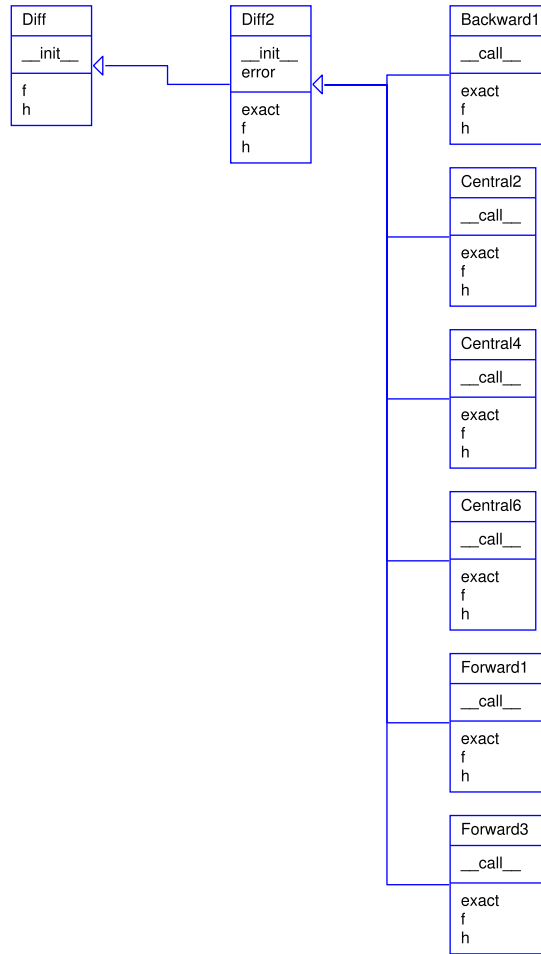

Fig. 9.2 UML diagram of the `Diff` hierarchy for a series of differentiation formulas (`Backward1`, `Central2`, etc.).

Here is an example of usage:

```
mycos = Forward1(sin, dfdx_exact=cos)
print 'Error in derivative is', mycos.error(x=pi)
```

The program flow of the `mycos.error(x=pi)` call can be interesting to follow. We first enter the `error` method in class `Diff2`, which then calls `self(x)`, i.e., the `__call__` method in class `Forward1`, which jumps out to the `self.f` function, i.e., the `sin` function in the `math` module in the present case. After returning to the `error` method, the next call is to `self.exact`, which is the `cos` function (from `math`) in our case.

Application. We can apply the methods in the `Diff2` hierarchy to get some insight into the accuracy of various difference formulas. Let us write out a table where the rows correspond to different h values, and the columns correspond to different approximation methods (except

the first column which reflects the h value). The values in the table can be the numerically computed $f'(x)$ or the error in this approximation if the exact derivative is known. The following function writes such a table:

```
def table(f, x, h_values, methods, dfdx=None):
    # Print headline (h and class names for the methods)
    print '      h      ',
    for method in methods:
        print '%-15s' % method.__name__,
    print # newline
    # Print table
    for h in h_values:
        print '%10.2E' % h,
        for method in methods:
            if dfdx is not None:          # write error
                d = method(f, h, dfdx)
                output = d.error(x)
            else:                          # write value
                d = method(f, h)
                output = d(x)
            print '%15.8E' % output,
        print # newline
```

The next lines tries three approximation methods on $f(x) = e^{-10x}$ for $x = 0$ and with $h = 1, 1/2, 1/4, 1/16, \dots, 1/512$:

```
from Diff2 import *
from math import exp

def f1(x):
    return exp(-10*x)

def df1dx(x):
    return -10*exp(-10*x)

table(f1, 0, [2**(-k) for k in range(10)],
      [Forward1, Central2, Central4], df1dx)
```

Note how convenient it is to make a list of class names – class names can be used as ordinary variables, and to print the class name as a string we just use the `__name__` attribute. The output of the main program above becomes

h	Forward1	Central2	Central4
1.00E+00	-9.00004540E+00	1.10032329E+04	-4.04157586E+07
5.00E-01	-8.01347589E+00	1.38406421E+02	-3.48320240E+03
2.50E-01	-6.32833999E+00	1.42008179E+01	-2.72010498E+01
1.25E-01	-4.29203837E+00	2.81535264E+00	-9.79802452E-01
6.25E-02	-2.56418286E+00	6.63876231E-01	-5.32825724E-02
3.12E-02	-1.41170013E+00	1.63556996E-01	-3.21608292E-03
1.56E-02	-7.42100948E-01	4.07398036E-02	-1.99260429E-04
7.81E-03	-3.80648092E-01	1.01756309E-02	-1.24266603E-05
3.91E-03	-1.92794011E-01	2.54332554E-03	-7.76243120E-07
1.95E-03	-9.70235594E-02	6.35795004E-04	-4.85085874E-08

From one row to the next, h is halved, and from about the 5th row and onwards, the Forward1 errors are also halved, which is consistent with the error $\mathcal{O}(h)$ of this method. Looking at the 2nd column, we see that the errors are reduced to $1/4$ when going from one row to the next, at least after the 5th row. This is also according to the theory since the error is proportional to h^2 . For the last row with a 4th-order scheme,

the error is reduced by $1/16$, which again is what we expect when the error term is $\mathcal{O}(h^4)$. What is also interesting to observe, is the benefit of using a higher-order scheme like `Central14`: with, for example, $h = 1/128$ the `Forward1` scheme gives an error of -0.7 , `Central12` improves this to 0.04 , while `Central14` has an error of -0.0002 . More accurate formulas definitely give better results⁵. The test example shown here is found in the file `Diff2_examples.py`.

9.2.4 Alternative Implementation via Functions

Could we implement the functionality offered by the `Diff` hierarchy of objects by using plain functions and no object orientation? The answer is “yes, almost”. What we have to pay for a pure function-based solution is a less friendly user interface to the differentiation functionality: More arguments must be supplied in function calls, because each difference formula, now coded as a straight Python function, must get $f(x)$, x , and h as arguments. In the class version we first store f and h as attributes in the constructor, and every time we want to compute the derivative, we just supply x as argument.

A Python function for implementing numerical differentiation reads

```
def central2_func(f, x, h=1.0E-5):
    return (f(x+h) - f(x-h))/(2*h)
```

The usage demonstrates the difference from the class solution:

```
mycos = central2_func(sin, pi, 1E-6)
# Compute sin'(pi):
print "g'(%g)=%g (exact value is %g)" % (pi, mycos, cos(pi))
```

Now, `mycos` is a number, not a callable object. The nice thing with the class solution is that `mycos` appeared to be a standard Python function whose mathematical values equal the derivative of the Python function `sin(x)`. But does it matter whether `mycos` is a function or a number? Yes, it matters if we want to apply the difference formula twice to compute the second-order derivative. When `mycos` is a callable object of type `Central2`, we just write

```
mysin = Central2(mycos)
# or
mysin = Central2(Central2(sin))

# Compute g''(pi):
print "g''(%g)=%g" % (pi, mysin(pi))
```

With the `central2_func` function, this composition will not work. Moreover, when the derivative is an object, we can send this object to any

⁵ Strictly speaking, it is the fraction of the work and the accuracy that counts: `Central14` needs four function evaluations, while `Central12` and `Forward1` only needs two.

algorithm that expects a mathematical function, and such algorithms include numerical integration, differentiation, interpolation, ordinary differential equation solvers, and finding zeros of equations, so the applications are many.

9.2.5 Alternative Implementation via Functional Programming

As a conclusion of the previous section, the great benefit of the object-oriented solution in Chapter 9.2.1 is that one can have some subclass instance `d` from the `Diff` (or `Diff2`) hierarchy and write `d(x)` to evaluate the derivative at a point `x`. The `d(x)` call behaves as if `d` were a standard Python function containing a manually coded expression for the derivative.

The `d(x)` interface to the derivative can also be obtained by other and perhaps more direct means than object-oriented programming. In programming languages where functions are ordinary objects that can be referred to by variables, as in Python, one can make a function that returns the right `d(x)` function according to the chosen numerical derivation rule. The code looks as this:

```
def differentiate(f, method, h=1.0E-5):
    h = float(h) # avoid integer division

    if method == 'Forward1':
        def Forward1(x):
            return (f(x+h) - f(x))/h
        return Forward1

    elif method == 'Backward1':
        def Backward1(x):
            return (f(x) - f(x-h))/h
        return Backward1
    ...
```

And the usage is like this:

```
mycos = differentiate(sin, 'Forward1')
mysin = differentiate(mycos, 'Forward1')
x = pi
print mycos(x), cos(x), mysin, -sin(x)
```

The surprising thing is that when we call `mycos(x)` we provide only `x`, while the function itself looks like

```
def Forward1(x):
    return (f(x+h) - f(x))/h
return Forward1
```

How do the parameters `f` and `h` get their values when we call `mycos(x)`? There is some magic attached to the `Forward1` function, or literally, there are some variables attached to `Forward1`: this function “remembers” the values of `f` and `h` that existed as local variables in the `differentiate` function when the `Forward1` function was defined.

In computer science terms, the `Forward1` always has access to variables in the *scope* in which the function was defined. The `Forward1` function is what is known as a *closure* in some computer languages. Closures are much used in a programming style called *functional programming*. Two key features of functional programming is operations on lists (like list comprehensions) and returning functions from functions. Python supports functional programming, but we will not consider this programming style further in this book.

9.2.6 Alternative Implementation via a Single Class

Instead of making many classes or functions for the many different differentiation schemes, the basic information about the schemes can be stored in one table. With a single method in one single class can use the table information, and for a given scheme, compute the derivative. To do this, we need to reformulate the mathematical problem (actually by using ideas from Chapter 9.3.1).

A family of numerical differentiation schemes can be written

$$f'(x) \approx h^{-1} \sum_{i=-r}^r w_i f(x_i), \quad (9.7)$$

where w_i are weights and x_i are points. The $2r+1$ points are symmetric around some point x :

$$x_i = x + ih, \quad i = -r, \dots, r.$$

The weights depend on the differentiation scheme. For example, the Midpoint scheme (9.3) has

$$w_{-1} = -1, \quad w_0 = 0, \quad w_1 = 1.$$

Table 9.1 lists the values of w_i for different difference formulas. In this table we have set $r = 4$, which is sufficient for the schemes written up in this book.

Given a table of the w_i values, we can use (9.7) to compute the derivative. A faster, vectorized computation can have the x_i , w_i , and $f(x_i)$ values as stored in three vectors. Then $h^{-1} \sum_i w_i f(x_i)$ can be interpreted as a dot product between the two vectors with components w_i and $f(x_i)$, respectively.

A class with the table of weights as a static variable, a constructor, and a `__call__` method for evaluating the derivative via $h^{-1} \sum_i w_i f(x_i)$ looks as follows:

Table 9.1 Weights in some difference schemes. The number after the nature of a scheme denotes the order of the schemes (for example, “central 2” is a central difference of 2nd order).

points	$x - 4h$	$x - 3h$	$x - 2h$	$x - h$	x	$x + h$	$x + 2h$	$x + 3h$	$x + 4h$
central 2	0	0	0	$-\frac{1}{2}$	0	$\frac{1}{2}$	0	0	0
central 4	0	0	$\frac{1}{12}$	$-\frac{2}{3}$	0	$\frac{2}{3}$	$-\frac{1}{12}$	0	0
central 6	0	$-\frac{1}{60}$	$\frac{3}{20}$	$-\frac{3}{4}$	0	$\frac{3}{4}$	$-\frac{3}{20}$	$\frac{1}{60}$	0
central 8	$\frac{1}{280}$	$-\frac{4}{105}$	$\frac{12}{60}$	$-\frac{4}{5}$	0	$\frac{4}{5}$	$-\frac{12}{60}$	$\frac{4}{105}$	$-\frac{1}{280}$
forward 1	0	0	0	0	1	1	0	0	0
forward 3	0	0	0	$-\frac{2}{6}$	$-\frac{1}{2}$	1	$-\frac{1}{6}$	0	0
backward 1	0	0	0	-1	1	0	0	0	0

```
class Diff3:
    table = {
        ('forward', 1):
        [0, 0, 0, 0, 1, 1, 0, 0, 0],
        ('central', 2):
        [0, 0, 0, -1./2, 0, 1./2, 0, 0, 0],
        ('central', 4):
        [ 0, 0, 1./12, -2./3, 0, 2./3, -1./12, 0, 0],
        ...
    }
    def __init__(self, f, h=1.0E-5, type='central', order=2):
        self.f, self.h, self.type, self.order = f, h, type, order
        self.weights = np.array(Diff2.table[(type, order)])

    def __call__(self, x):
        f_values = np.array([f(self.x+i*self.h) \
                             for i in range(-4,5)])
        return np.dot(self.weights, f_values)/self.h
```

Here we used numpy’s `dot(x, y)` function for computing the inner or dot product between two arrays `x` and `y`.

Class `Diff3` can be found in the file `Diff3.py`. Using class `Diff3` to differentiate the sine function goes like this:

```
import Diff3
mycos = Diff3.Diff3(sin, type='central', order=4)
print "sin'(pi):", mycos(pi)
```

Remark. The downside of class `Diff3`, compared with the other implementation techniques, is that the sum $h^{-1} \sum_i w_i f(x_i)$ contains many multiplications by zero for lower-order schemes. These multiplications are known to yield zero in advance so we waste computer resources on trivial calculations. Once upon a time, programmers would have been extremely careful to avoid wasting multiplications this way, but today arithmetic operations are quite cheap, especially compared to fetching data from the computer’s memory. Lots of other factors also influence the computational efficiency of a program, but this is beyond the scope of this book.

9.3 Class Hierarchy for Numerical Integration

There are many different numerical methods for integrating a mathematical function, just as there are many different methods for differentiating a function. It is thus obvious that the idea of object-oriented programming and class hierarchies can be applied to numerical integration formulas in the same manner as we did in Chapter 9.2.

9.3.1 Numerical Integration Methods

First, we list some different methods for integrating $\int_a^b f(x)dx$ using n evaluation points. All the methods can be written as

$$\int_a^b f(x)dx \approx \sum_{i=0}^{n-1} w_i f(x_i), \quad (9.8)$$

where w_i are weights and x_i are evaluation points, $i = 0, \dots, n-1$. The Midpoint method has

$$x_i = a + \frac{h}{2} + ih, \quad w_i = h, \quad h = \frac{b-a}{n}, \quad i = 0, \dots, n-1. \quad (9.9)$$

The Trapezoidal method has the points

$$x_i = a + ih, \quad h = \frac{b-a}{n-1}, \quad i = 0, \dots, n-1, \quad (9.10)$$

and the weights

$$w_0 = w_{n-1} = \frac{h}{2}, \quad w_i = h, \quad i = 1, \dots, n-2. \quad (9.11)$$

Simpson's rule has the same evaluation points as the Trapezoidal rule, but

$$h = 2\frac{b-a}{n-1}, \quad w_0 = w_{n-1} = \frac{h}{6}, \quad (9.12)$$

$$w_i = \frac{h}{3} \quad \text{for } i = 2, 4, \dots, n-3, \quad (9.13)$$

$$w_i = \frac{2h}{3} \quad \text{for } i = 1, 3, 5, \dots, n-2. \quad (9.14)$$

Note that n must be odd in Simpson's rule. A Two-Point Gauss-Legendre method takes the form

$$x_i = a + \left(i + \frac{1}{2}\right)h - \frac{1}{\sqrt{3}}\frac{h}{2} \quad \text{for } i = 0, 2, 4, \dots, n-2, \quad (9.15)$$

$$x_i = a + \left(i + \frac{1}{2}\right)h + \frac{1}{\sqrt{3}}\frac{h}{2} \quad \text{for } i = 1, 3, 5, \dots, n-1, \quad (9.16)$$

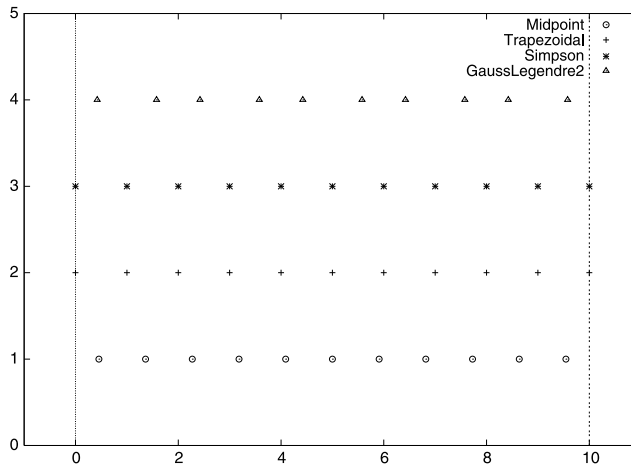

Fig. 9.3 Illustration of the distribution of points for various numerical integration methods. The Gauss-Legendre method has 10 points, while the other methods have 11 points in $[0, 10]$.

with $h = 2(b - a)/n$. Here n must be even. All the weights have the same value: $w_i = h/2$, $i = 0, \dots, n - 1$. Figure 9.3 illustrates how the points in various integration rules are distributed over a few intervals.

9.3.2 Classes for Integration

We may store x_i and w_i in two NumPy arrays and compute the integral as $\sum_{i=0}^{n-1} w_i f(x_i)$. This operation can also be vectorized as a dot (inner) product between the w_i vector and the $f(x_i)$ vector, provided $f(x)$ is implemented in a vectorizable form.

We argued in Chapter 7.3.3 that it pays off to implement a numerical integration formula as a class. If we do so with the different methods from the previous section, a typical class looks like this:

```
class SomeIntegrationMethod:
    def __init__(self, a, b, n):
        # Compute self.points and self.weights

    def integrate(self, f):
        s = 0
        for i in range(len(self.weights)):
            s += self.weights[i]*f(self.points[i])
        return s
```

Making such classes for many different integration methods soon reveals that all the classes contain common code, namely the `integrate` method for computing $\sum_{i=0}^{n-1} w_i f(x_i)$. Therefore, this common code can be placed in a superclass, and subclasses can just add the code that is specific to a certain numerical integration formula, namely the definition of the weights w_i and the points x_i .

Let us start with the superclass:

```
class Integrator:
    def __init__(self, a, b, n):
        self.a, self.b, self.n = a, b, n
        self.points, self.weights = self.construct_method()

    def construct_method(self):
        raise NotImplementedError('no rule in class %s' %
                                  self.__class__.__name__)

    def integrate(self, f):
        s = 0
        for i in range(len(self.weights)):
            s += self.weights[i]*f(self.points[i])
        return s
```

As we have seen, we store the a , b , and n data about the integration method in the constructor. Moreover, we compute arrays or lists `self.points` for the x_i points and `self.weights` for the w_i weights. All this code can now be inherited by all subclasses.

The initialization of points and weights is put in a separate method, `construct_method`, which is supposed to be implemented in each subclass, but the superclass provides a default implementation which tells the user that the method is not implemented. What happens is that when subclasses redefine a method, that method overrides the method inherited from the superclass. Hence, if we forget to redefine `construct_method` in a subclass, we will inherit the one from the superclass, and this method issues an error message. The construction of this error message is quite clever in the sense that it will tell in which class the `construct_method` method is missing (`self` will be the subclass instance and its `__class__.__name__` is a string with the corresponding subclass name).

In computer science one usually speaks about *overloading* a method in a subclass, but the words redefining and overriding are also used. A method that is overloaded is said to be *polymorphic*. A related term, *polymorphism*, refers to coding with polymorphic methods. Very often, a superclass provides some default implementation of a method, and a subclass overloads the method with the purpose of tailoring the method to a particular application.

The `integrate` method is common for all integration rules, i.e., for all subclasses, so it can be inherited as it is. A vectorized version can also be added in the superclass to make it automatically available also in all subclasses:

```
def vectorized_integrate(self, f):
    return np.dot(self.weights, f(self.points))
```

Let us then implement a subclass. Only the `construct_method` method needs to be written. For the Midpoint rule, this is a matter of translating the formulas in (9.9) to Python:

```
class Midpoint(Integrator):
    def construct_method(self):
        a, b, n = self.a, self.b, self.n # quick forms
        h = (b-a)/float(n)
        x = np.linspace(a + 0.5*h, b - 0.5*h, n)
        w = np.zeros(len(x)) + h
        return x, w
```

Observe that we implemented directly a vectorized code. We could also have used (slow) loops and explicit indexing:

```
x = np.zeros(n)
w = np.zeros(n)
for i in range(n):
    x[i] = a + 0.5*h + i*h
    w[i] = h
```

Before we continue with other subclasses for other numerical integration formulas, we will have a look at the program flow when we use class `Midpoint`. Suppose we want to integrate $\int_0^2 x^2 dx$ using 101 points:

```
def f(x): return x*x
m = Midpoint(0, 2, 101)
print m.integrate(f)
```

How is the program flow? The assignment to `m` invokes the constructor in class `Midpoint`. Since this class has no constructor, we invoke the inherited one from the superclass `Integrator`. Here attributes are stored, and then the `construct_method` method is called. Since `self` is a `Midpoint` instance, it is the `construct_method` in the `Midpoint` class that is invoked, even if there is a method with the same name in the superclass. Class `Midpoint` overloads `construct_method` in the superclass. In a way, we “jump down” from the constructor in class `Integrator` to the `construct_method` in the `Midpoint` class. The next statement, `m.integrate(f)`, just calls the inherited `integral` method that is common to all subclasses.

A vectorized Trapezoidal rule can be implemented in another subclass with name `Trapezoidal`:

```
class Trapezoidal(Integrator):
    def construct_method(self):
        x = np.linspace(self.a, self.b, self.n)
        h = (self.b - self.a)/float(self.n - 1)
        w = np.zeros(len(x)) + h
        w[0] /= 2
        w[-1] /= 2
        return x, w
```

Observe how we divide the first and last weight by 2, using index 0 (the first) and `-1` (the last) and the `/=` operator (`a /= b` is equivalent to `a = a/b`). Here also we could have implemented a scalar version with loops. The relevant code is in function `trapezoidal` in Chapter 7.3.3.

Class `Simpson` has a slightly more demanding rule, at least if we want to vectorize the expression, since the weights are of two types.

```
class Simpson(Integrator):
    def construct_method(self):
        if self.n % 2 != 1:
            print 'n=%d must be odd, 1 is added' % self.n
            self.n += 1
        x = np.linspace(self.a, self.b, self.n)
        h = (self.b - self.a)/float(self.n - 1)*2
        w = np.zeros(len(x))
        w[0:self.n:2] = h*1.0/3
        w[1:self.n-1:2] = h*2.0/3
        w[0] /= 2
        w[-1] /= 2
        return x, w
```

We first control that we have an odd number of points, by checking that the remainder of `self.n` divided by two is 1. If not, an exception could be raised, but for smooth operation of the class, we simply increase `n` so it becomes odd. Such automatic adjustments of input is not a rule to be followed in general. Wrong input is best notified explicitly. However, sometimes it is user friendly to make small adjustments of the input, as we do here, to achieve a smooth and successful operation. (In cases like this, a user might become uncertain whether the answer can be trusted if she (later) understands that the input should not yield a correct result. Therefore, do the adjusted computation, and provide a notification to the user about what has taken place.)

The computation of the weights `w` in class `Simpson` applies slices with stride (jump/step) 2 such that the operation is vectorized for speed. Recall that the upper limit of a slice is not included in the set, so `self.n-1` is the largest index in the first case, and `self.n-2` is the largest index in the second case. Instead of the vectorized operation of slices for computing `w`, we could use (slower) straight loops:

```
for i in range(0, self.n, 2):
    w[i] = h*1.0/3
for i in range(1, self.n-1, 2):
    w[i] = h*2.0/3
```

The points in the Two-Point Gauss-Legendre rule are slightly more complicated to calculate, so here we apply straight loops to make a safe first implementation:

```
class GaussLegendre2(Integrator):
    def construct_method(self):
        if self.n % 2 != 0:
            print 'n=%d must be even, 1 is subtracted' % self.n
            self.n -= 1
        nintervals = int(self.n/2.0)
        h = (self.b - self.a)/float(nintervals)
        x = np.zeros(self.n)
        sqrt3 = 1.0/math.sqrt(3)
        for i in range(nintervals):
            x[2*i] = self.a + (i+0.5)*h - 0.5*sqrt3*h
            x[2*i+1] = self.a + (i+0.5)*h + 0.5*sqrt3*h
```

```
w = np.zeros(len(x)) + h/2.0
return x, w
```

A vectorized calculation of x is possible by observing that the $(i+0.5)*h$ expression can be computed by `np.linspace`, and then we can add the remaining two terms:

```
m = np.linspace(0.5*h, (nintervals-1+0.5)*h, nintervals)
x[0:self.n-1:2] = m + self.a - 0.5*sqrt3*h
x[1:self.n:2]   = m + self.a + 0.5*sqrt3*h
```

The array on the right-hand side has half the length of x ($n/2$), but the length matches exactly the slice with stride 2 on the left-hand side.

9.3.3 Using the Class Hierarchy

To verify the implementation, we first try to integrate a linear function. All methods should compute the correct integral value regardless of the number of evaluation points:

```
def f(x):
    return x + 2

a = 2; b = 3; n = 4
for Method in Midpoint, Trapezoidal, Simpson, GaussLegendre2:
    m = Method(a, b, n)
    print m.__class__.__name__, m.integrate(f)
```

Observe how we simply list the class names as a tuple (comma-separated objects), and `Method` will in the `for` loop attain the values `Midpoint`, `Trapezoidal`, and so forth. For example, in the first pass of the loop, `Method(a, b, n)` is identical to `Midpoint(a, b, n)`.

The output of the test above becomes

```
Midpoint 4.5
Trapezoidal 4.5
n=4 must be odd, 1 is added
Simpson 4.5
GaussLegendre2 4.5
```

Since $\int_2^3 (x+2)dx = \frac{9}{2} = 4.5$, all methods passed this simple test.

A more challenging integral, from a numerical point of view, is

$$\int_0^1 \left(1 + \frac{1}{m}\right) t^{\frac{1}{m}} dt = 1.$$

To use any subclass in the `Integrator` hierarchy, the integrand must be a function of one variable only. For the present integrand, which depends on t and m , we use a class to represent it:

```
class F:
    def __init__(self, m):
        self.m = float(m)
```

```
def __call__(self, t):
    m = self.m
    return (1 + 1/m)*t**(1/m)
```

We now ask the question: How much is the error in the integral reduced as we increase the number of integration points (n)? It appears that the error decreases exponentially with n , so if we want to plot the errors versus n , it is best to plot the logarithm of the error versus $\ln n$. We expect this graph to be a straight line, and the steeper the line is, the faster the error goes to zero as n increases. A common conception is to regard one numerical method as better than another if the error goes faster to zero as we increase the computational work (here n).

For a given m and method, the following function computes two lists containing the logarithm of the n values, and the logarithm of the corresponding errors in a series of experiments:

```
def error_vs_n(f, exact, n_values, Method, a, b):
    log_n = [] # log of actual n values (Method may adjust n)
    log_e = [] # log of corresponding errors
    for n_value in n_values:
        method = Method(a, b, n_value)
        error = abs(exact - method.integrate(f))
        log_n.append(log(method.n))
        log_e.append(log(error))
    return log_n, log_e
```

We can plot the error versus n for several methods in the same plot and make one plot for each m value. The loop over m below makes such plots:

```
n_values = [10, 20, 40, 80, 160, 320, 640]
for m in 1./4, 1./8., 2, 4, 16:
    f = F(m)
    figure()
    for Method in Midpoint, Trapezoidal, \
        Simpson, GaussLegendre2:
        n, e = error_vs_n(f, 1, n_values, Method, 0, 1)
        plot(n, e); legend(Method.__name__); hold('on')
    title('m=%g' % m); xlabel('ln(n)'); ylabel('ln(error)')
```

The code snippets above are collected in a function `test` in the `integrate.py` file.

The plots for $m > 1$ look very similar. The plots for $0 < m < 1$ are also similar, but different from the $m > 1$ cases. Let us have a look at the results for $m = 1/4$ and $m = 2$. The first, $m = 1/4$, corresponds to $\int_0^1 5x^4 dx$. Figure 9.4 shows that the error curves for the Trapezoidal and Midpoint methods converge more slowly compared to the error curves for Simpson's rule and the Gauss-Legendre method. This is the usual situation for these methods, and mathematical analysis of the methods can confirm the results in Figure 9.4.

However, when we consider the integral $\int_0^1 \frac{3}{2}\sqrt{x} dx$, ($m = 2$) and $m > 1$ in general, all the methods converge with the same speed, as shown in Figure 9.5. Our integral is difficult to compute numerically

when $m > 1$, and the theoretically better methods (Simpson's rule and the Gauss-Legendre method) do not converge faster than the simpler methods. The difficulty is due to the infinite slope (derivative) of the integrand at $x = 0$.

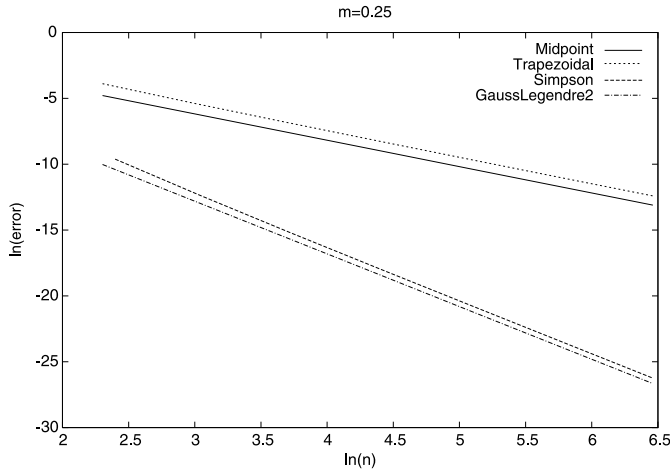

Fig. 9.4 The logarithm of the error versus the logarithm of integration points for integral $5x^4$ computed by the Trapezoidal and Midpoint methods (upper two lines), and Simpson's rule and the Gauss-Legendre methods (lower two lines).

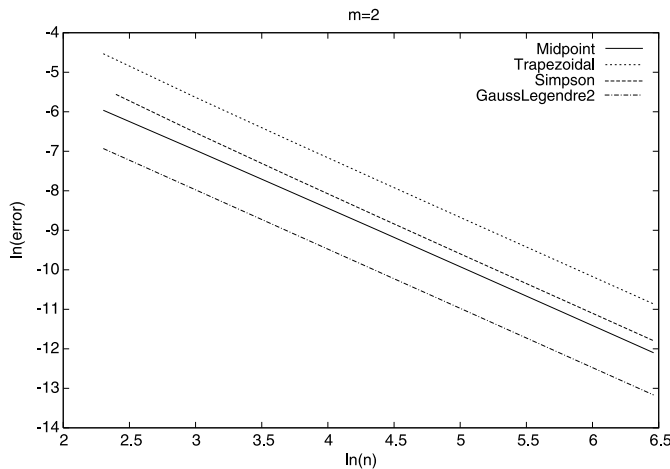

Fig. 9.5 The logarithm of the error versus the logarithm of integration points for integral $\frac{3}{2}\sqrt{x}$ computed by the Trapezoidal method and Simpson's rule (upper two lines), and Midpoint and Gauss-Legendre methods (lower two lines).

9.3.4 About Object-Oriented Programming

From an implementational point of view, the advantage of class hierarchies in Python is that we can save coding by inheriting functionality

from a superclass. In programming languages where each variable must be specified with a fixed type, class hierarchies are particularly useful because a function argument with a special type also works with all subclasses of that type. Suppose we have a function where we need to integrate:

```
def do_math(arg1, arg2, integrator):  
    ...  
    I = integrator.integrate(myfunc)  
    ...
```

That is, `integrator` must be an instance of some class, or a module, such that the syntax `integrator.integrate(myfunc)` corresponds to a function call, but nothing more (like having a particular type) is demanded.

This Python code will run as long as `integrator` has a method `integrate` taking one argument. In other languages, the function arguments are specified with a type, say in Java we would write

```
void do_math(double arg1, int arg2, Simpson integrator)
```

A compiler will examine all calls to `do_math` and control that the arguments are of the right type. Instead of specifying the integration method to be of type `Simpson`, one can in Java and other object-oriented languages specify `integrator` to be of the superclass type `Integrator`:

```
void do_math(double arg1, int arg2, Integrator integrator)
```

Now it is allowed to pass an object of any subclass type of `Integrator` as the third argument. That is, this method works with `integrator` of type `Midpoint`, `Trapezoidal`, `Simpson`, etc., not just one of them. Class hierarchies and object-oriented programming are therefore important means for parameterizing away types in languages like Java, C++, and C#. We do not need to parameterize types in Python, since arguments are not declared with a fixed type. Object-oriented programming is hence not so technically important in Python as in other languages for providing increased flexibility in programs.

Is there then any use for object-oriented programming beyond inheritance? The answer is yes! For many code developers object-oriented programming is not just a technical way of sharing code, but it is more a way of modeling the world, and understanding the problem that the program is supposed to solve. In mathematical applications we already have objects, defined by the mathematics, and standard programming concepts such as functions, arrays, lists, and loops are often sufficient for solving simpler problems. In the non-mathematical world the concept of objects is very useful because it helps to structure the problem to be solved. As an example, think of the phone book and message list software in a mobile phone. Class `Person` can be introduced to hold the data about one person in the phone book, while class `Message` can hold data related to an SMS message. Clearly, we need to know who sent a

message so a `Message` object will have an associated `Person` object, or just a phone number if the number is not registered in the phone book. Classes help to structure both the problem and the program. The impact of classes and object-oriented programming on modern software development can hardly be exaggerated.

A good, real-world, pedagogical example on inheritance is the class hierarchy for numerical methods for ordinary differential equations described in Appendix E.2.

9.4 Class Hierarchy for Making Drawings

Implementing a drawing program provides a very good example on the usefulness of object-oriented programming. In the following we shall develop the simpler parts of a relatively small and compact drawing program for making sketches of the type shown in Figure 9.6. This is a typical *principal sketch* of a physics problem, here involving a rolling wheel on an inclined plane. The sketch is made up many individual elements: a rectangle filled with a pattern (the inclined plane), a hollow circle with color (the wheel), arrows with labels (the N and Mg forces, and the x axis), an angle with symbol θ , and a dashed line indicating the starting location of the wheel.

Drawing software and plotting programs can produce such figures quite easily in principle, but the amount of details the user needs to control with the mouse can be substantial. Software more tailored to producing sketches of this type would work with more convenient abstractions, such as circle, wall, angle, force arrow, axis, and so forth. And as soon we start *programming* to construct the figure we get a range of other powerful tools at disposal. For example, we can easily translate and rotate parts of the figure and make an animation that

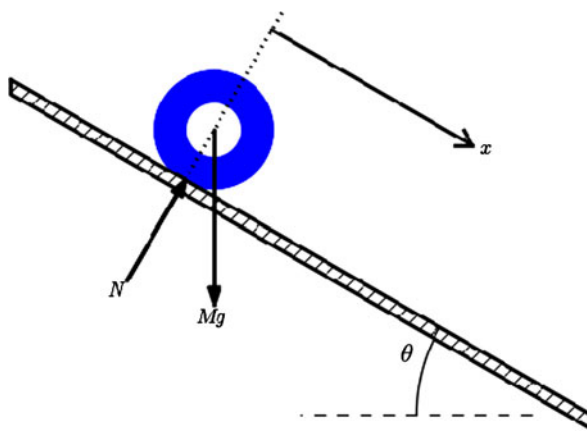

Fig. 9.6 Sketch of a physics problem.

illustrates the physics of the problem. Programming as a superior alternative to interactive drawing is the mantra of this section.

Classes are very suitable for implementing the various components that build up a sketch. In particular, we shall demonstrate that as soon as some classes are established, more are easily added. Enhanced functionality for all the classes is also easy to implement in common, generic code that can immediately be shared by all present and future classes.

The fundamental data structure involved in this case study is a hierarchical tree, and much of the material on implementation issues targets how to traverse tree structures with recursive function calls. This topic is of key relevance in a wide range of other applications as well.

9.4.1 Using the Object Collection

We start by demonstrating a convenient user interface for making sketches of the type in Figure 9.6. However, it is more appropriate to start with a significantly simpler example as depicted in Figure 9.7. This toy sketch consists of several elements: two circles, two rectangles, and a “ground” element.

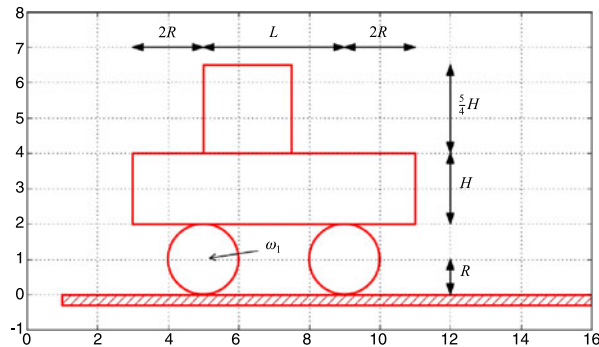

Fig. 9.7 Sketch of a simple figure.

Basic Drawing. A typical program creating these five elements is shown next. After importing the `pysketcher` package, the first task is always to define a coordinate system:

```
from pysketcher import *
drawing_tool.set_coordinate_system(
    xmin=0, xmax=10, ymin=-1, ymax=8)
```

Instead of working with lengths expressed by specific numbers it is highly recommended to use variables to parameterize lengths as this makes it easier to change dimensions later. Here we introduce some

key lengths for the radius of the wheels, distance between the wheels, etc.:

```
R = 1    # radius of wheel
L = 4    # distance between wheels
H = 2    # height of vehicle body
w_1 = 5  # position of front wheel
drawing_tool.set_coordinate_system(xmin=0, xmax=w_1 + 2*L + 3*R,
                                  ymin=-1, ymax=2*R + 3*H)
```

With the drawing area in place we can make the first `Circle` object in an intuitive fashion:

```
wheel1 = Circle(center=(w_1, R), radius=R)
```

to change dimensions later.

To translate the geometric information about the `wheel1` object to instructions for the plotting engine (in this case Matplotlib), one calls the `wheel1.draw()`. To display all drawn objects, one issues `drawing_tool.display()`. The typical steps are hence:

```
wheel1 = Circle(center=(w_1, R), radius=R)
wheel1.draw()

# Define other objects and call their draw() methods
drawing_tool.display()
drawing_tool.savefig('tmp.png') # store picture
```

The next wheel can be made by taking a copy of `wheel1` and translating the object to the right according to a displacement vector $(L, 0)$:

```
wheel2 = wheel1.copy()
wheel2.translate((L,0))
```

The two rectangles are also made in an intuitive way:

```
under = Rectangle(lower_left_corner=(w_1-2*R, 2*R),
                  width=2*R + L + 2*R, height=H)
over  = Rectangle(lower_left_corner=(w_1, 2*R + H),
                  width=2.5*R, height=1.25*H)
```

Groups of Objects. Instead of calling the `draw` method of every object, we can group objects and call `draw`, or perform other operations, for the whole group. For example, we may collect the two wheels in a `wheels` group and the `over` and `under` rectangles in a `body` group. The whole vehicle is a composition of its `wheels` and `body` groups. The code goes like

```
wheels = Composition({'wheel1': wheel1, 'wheel2': wheel2})
body   = Composition({'under': under, 'over': over})
vehicle = Composition({'wheels': wheels, 'body': body})
```

The ground is illustrated by an object of type `Wall`, mostly used to indicate walls in sketches of mechanical systems. A `Wall` takes the x and

y coordinates of some curve, and a thickness parameter, and creates a “thick” curve filled with a simple pattern. In this case the curve is just a flat line so the construction is made of two points on the ground line $((w_1 - L, 0)$ and $(w_1 + 3L, 0)$):

```
ground = Wall(x=[w_1 - L, w_1 + 3*L], y=[0, 0], thickness=-0.3*R)
```

The negative thickness makes the pattern-filled rectangle appear below the defined line, otherwise it appears above.

We may now collect all the objects in a “top” object that contains the whole figure:

```
fig = Composition({'vehicle': vehicle, 'ground': ground})
fig.draw() # send all figures to plotting backend
drawing_tool.display()
drawing_tool.savefig('tmp.png')
```

The `fig.draw()` call will visit all subgroups, their subgroups, and so forth in the hierarchical tree structure of figure elements, and call `draw` for every object.

Changing Line Styles and Colors. Controlling the line style, line color, and line width is fundamental when designing figures. The `pysketcher` package allows the user to control such properties in single objects, but also set global properties that are used if the object has no particular specification of the properties. Setting the global properties are done like

```
drawing_tool.set_linestyle('dashed')
drawing_tool.set_linecolor('black')
drawing_tool.set_linewidth(4)
```

At the object level the properties are specified in a similar way:

```
wheels.set_linestyle('solid')
wheels.set_linecolor('red')
```

and so on.

Geometric figures can be specified as *filled*, either with a color or with a special visual pattern:

```
# Set filling of all curves
drawing_tool.set_filled_curves(color='blue', pattern='/')

# Turn off filling of all curves
drawing_tool.set_filled_curves(False)

# Fill the wheel with red color
wheel1.set_filled_curves('red')
```

The Figure Composition as an Object Hierarchy. The composition of objects making up the figure is hierarchical, similar to a family, where each object has a parent and a number of children. Do a `print fig` to display the relations:

```

ground
  wall
vehicle
  body
    over
      rectangle
    under
      rectangle
  wheels
    wheel1
      arc
    wheel2
      arc

```

The indentation reflects how deep down in the hierarchy (family) we are. This output is to be interpreted as follows:

- `fig` contains two objects, `ground` and `vehicle`
- `ground` contains an object `wall`
- `vehicle` contains two objects, `body` and `wheels`
- `body` contains two objects, `over` and `under`
- `wheels` contains two objects, `wheel1` and `wheel2`

In this listing there are also objects not defined by the programmer: `rectangle` and `arc`. These are of type `Curve` and automatically generated by the classes `Rectangle` and `Circle`.

More detailed information can be printed by

```
print fig.show_hierarchy('std')
```

yielding the output

```

ground (Wall):
  wall (Curve): 4 coords fillcolor='white' fillpattern='/'
vehicle (Composition):
  body (Composition):
    over (Rectangle):
      rectangle (Curve): 5 coords
    under (Rectangle):
      rectangle (Curve): 5 coords
  wheels (Composition):
    wheel1 (Circle):
      arc (Curve): 181 coords
    wheel2 (Circle):
      arc (Curve): 181 coords

```

Here we can see the class type for each figure object, how many coordinates that are involved in basic figures (`Curve` objects), and special settings of the basic figure (fillcolor, line types, etc.). For example, `wheel2` is a `Circle` object consisting of an `arc`, which is a `Curve` object consisting of 181 coordinates (the points needed to draw a smooth circle). The `Curve` objects are the only objects that really holds specific coordinates to be drawn. The other object types are just compositions used to group parts of the complete figure.

One can also get a graphical overview of the hierarchy of figure objects that build up a particular figure `fig`. Just call `fig.graphviz_dot('fig')` to produce a file `fig.dot` in the *dot format*. This file contains relations between parent and child objects

in the figure and can be turned into an image, as in Figure 9.8, by running the dot program:

```
Terminal
Terminal> dot -Tpng -o fig.png fig.dot
```

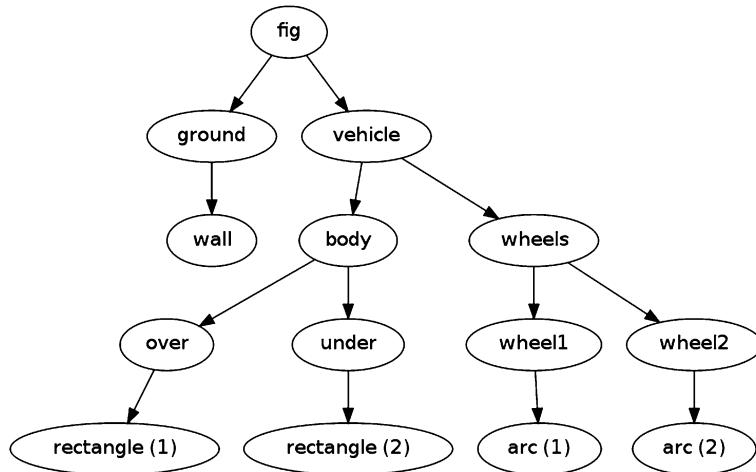

Fig. 9.8 Hierarchical relation between figure objects.

The call `fig.graphviz_dot('fig', classname=True)` makes a `fig.dot` file where the class type of each object is also visible, see Figure 9.9. The ability to write out the object hierarchy or view it graphically can be of great help when working with complex figures that involve layers of subfigures.

Any of the objects can in the program be reached through their names, e.g.,

```
fig['vehicle']
fig['vehicle']['wheels']
fig['vehicle']['wheels']['wheel2']
fig['vehicle']['wheels']['wheel2']['arc']
fig['vehicle']['wheels']['wheel2']['arc'].x # x coords
fig['vehicle']['wheels']['wheel2']['arc'].y # y coords
fig['vehicle']['wheels']['wheel2']['arc'].linestyle
fig['vehicle']['wheels']['wheel2']['arc'].linetype
```

Grabbing a part of the figure this way is handy for changing properties of that part, for example, colors, line styles (see Figure 9.10):

```
fig['vehicle']['wheels'].set_filled_curves('blue')
fig['vehicle']['wheels'].set_linewidth(6)
fig['vehicle']['wheels'].set_linecolor('black')

fig['vehicle']['body']['under'].set_filled_curves('red')

fig['vehicle']['body']['over'].set_filled_curves(pattern='/')
fig['vehicle']['body']['over'].set_linewidth(14)
fig['vehicle']['body']['over']['rectangle'].linewidth = 4
```

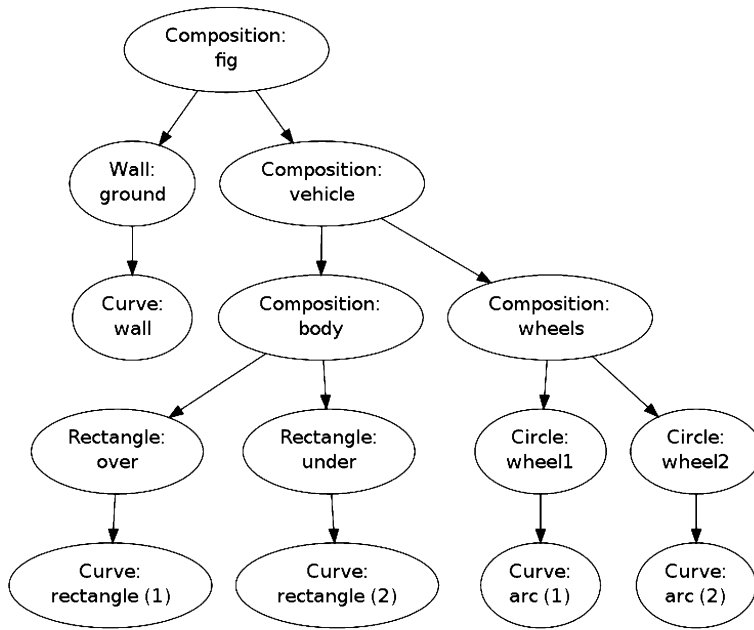



Fig. 9.9 Hierarchical relation between figure objects, including their class names.

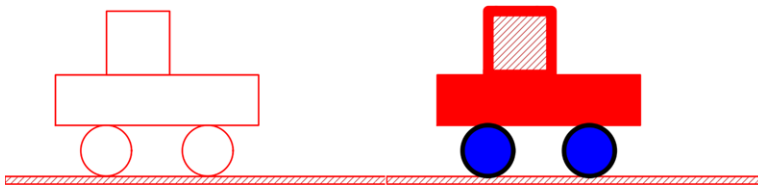

Fig. 9.10 Left: Basic line-based drawing. Right: Thicker lines and filled parts.

The last line accesses the `Curve` object directly, while the line above, accesses the `Rectangle` object which will then set the linewidth of its `Curve` object, and other objects if it had any. The result of the actions above is shown in Figure 9.10.

We can also change position of parts of the figure and thereby make animations, as shown next.

Animation: Translating the Vehicle. Can we make our little vehicle roll? A first attempt will be to fake rolling by just displacing all parts of the vehicle. The relevant parts constitute the `fig['vehicle']` object. This part of the figure can be translated, rotated, and scaled. A translation along the ground means a translation in x direction, say a length L to the right:

```
fig['vehicle'].translate((L,0))
```

You need to erase, draw, and display to see the movement:

```
drawing_tool.erase()
fig.draw()
drawing_tool.display()
```

Without erasing, the old drawing of the vehicle will remain in the figure so you get two vehicles. Without `fig.draw()` the new coordinates of the vehicle will not be communicated to the drawing tool, and without calling `display` the updated drawing will not be visible.

A figure that moves in time is conveniently realized by the function `animate`:

```
animate(fig, tp, action)
```

Here, `fig` is the entire figure, `tp` is an array of time points, and `action` is a user-specified function that changes `fig` at a specific time point. Typically, `action` will move parts of `fig`.

In the present case we can define the movement through a velocity function $v(t)$ and displace the figure $v(t)*dt$ for small time intervals dt . A possible velocity function is

```
def v(t):
    return -8*R*t*(1 - t/(2*R))
```

Our action function for horizontal displacements $v(t)*dt$ becomes

```
def move(t, fig):
    x_displacement = dt*v(t)
    fig['vehicle'].translate((x_displacement, 0))
```

Since our velocity is negative for $t \in [0, 2R]$ the displacement is to the left.

The `animate` function will for each time point `t` in `tp` erase the drawing, call `action(t, fig)`, and show the new figure by `fig.draw()` and `drawing_tool.display()`. Here we choose a resolution of the animation corresponding to 25 time points in the time interval $[0, 2R]$:

```
import numpy
tp = numpy.linspace(0, 2*R, 25)
dt = tp[1] - tp[0] # time step

animate(fig, tp, move, pause_per_frame=0.2)
```

The `pause_per_frame` adds a pause, here 0.2 seconds, between each frame in the animation.

We can also ask `animate` to store each frame in a file:

```
files = animate(fig, tp, move_vehicle, moviefiles=True,
                pause_per_frame=0.2)
```

The `files` variable, here `'tmp_frame*.png'`, is a string expressing the family of frame files. This string can be used directly in commands

for making a movie out of the files. A simple approach is to generate an animated GIF file with help of the `convert` program from the ImageMagick software suite:

```
Terminal> convert -delay 20 tmp_frame*.png anim.gif
Terminal> animate anim.gif # play movie
```

The delay between frames governs the speed of the movie. The `anim.gif` file can be embedded in a web page and shown as a movie when the page is loaded into a web browser (just insert `` in the HTML code).

The tool `ffmpeg` can alternatively be used to create an MPEG movie, e.g.,

```
Terminal> ffmpeg -i "tmp_frame_%04d.png" -b 800k -r 25 \
-vcodec mpeg4 -y -qmin 2 -qmax 31 anim.mpeg
```

An easy-to-use Python interface to movie-making tools is provided by the SciTools package:

```
from scitools.std import movie

# HTML page showing individual frames
movie(files, encoder='html', output_file='anim.html')

# Standard GIF file
movie(files, encoder='convert', output_file='anim.gif')

# AVI format
movie('tmp_*.png', encoder='ffmpeg', fps=4,
      output_file='anim.avi') # requires ffmpeg package

# MPEG format
movie('tmp_*.png', encoder='ffmpeg', fps=4,
      output_file='anim2.mpeg', vcodec='mpeg2video')

# or
movie(files, encoder='ppmtompeg', fps=24,
      output_file='anim.mpeg') # requires the netpbm package
```

When difficulties with encoders and players arise, the simple web page for showing a movie, here `anim.html` (generated by the first `movie` command above), is a safe method that you always can rely on. You can try loading `anim.html` into a web browser, after first having run the present example in the file `vehicle0.py`.

Animation: Rolling the Wheels. It is time to show rolling wheels. To this end, we add spokes to the wheels, formed by two crossing lines, see Figure 9.11. The construction of the wheels will now involve a circle and two lines:

```

wheel1 = Composition({
    'wheel': Circle(center=(w_1, R), radius=R),
    'cross': Composition({'cross1': Line((w_1,0), (w_1,2*R)),
                        'cross2': Line((w_1-R,R), (w_1+R,R))}))
wheel2 = wheel1.copy()
wheel2.translate((L,0))

```

Observe that `wheel1.copy()` copies all the objects that make up the first wheel, and `wheel2.translate` translates all the copied objects.

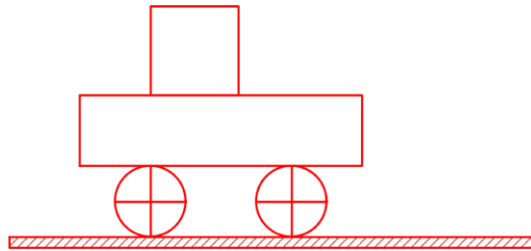

Fig. 9.11 Wheels with spokes to illustrate rolling.

The `move` function now needs to displace all the objects in the entire vehicle and also rotate the `cross1` and `cross2` objects in both wheels. The rotation angle follows from the fact that the arc length of a rolling wheel equals the displacement of the center of the wheel, leading to a rotation angle

```
angle = - x_displacement/R
```

With `w_1` tracking the x coordinate of the center of the front wheel, we can rotate that wheel by

```

w1 = fig['vehicle']['wheels']['wheel1']
from math import degrees
w1.rotate(degrees(angle), center=(w_1, R))

```

The `rotate` function takes two parameters: the rotation angle (in degrees) and the center point of the rotation, which is the center of the wheel in this case. The other wheel is rotated by

```

w2 = fig['vehicle']['wheels']['wheel2']
w2.rotate(degrees(angle), center=(w_1 + L, R))

```

That is, the angle is the same, but the rotation point is different. The update of the center point is done by `w_1 += x_displacement`. The complete `move` function with translation of the entire vehicle and rotation of the wheels then becomes

```

w_1 = w_1 + L # start position

def move(t, fig):
    x_displacement = dt*v(t)
    fig['vehicle'].translate((x_displacement, 0))

```

```

# Rotate wheels
global w_1
w_1 += x_displacement
# R*angle = -x_displacement
angle = - x_displacement/R
w1 = fig['vehicle']['wheels']['wheel1']
w1.rotate(degrees(angle), center=(w_1, R))
w2 = fig['vehicle']['wheels']['wheel2']
w2.rotate(degrees(angle), center=(w_1 + L, R))

```

The complete example is found in the file `vehicle1.py`.

The advantages with making figures this way, through programming rather than using interactive drawing programs, are numerous. For example, the objects are parameterized by variables so that various dimensions can easily be changed. Subparts of the figure, possibly involving a lot of figure objects, can change color, linestyle, filling or other properties through a *single* function call. Subparts of the figure can be rotated, translated, or scaled. Subparts of the figure can also be copied and moved to other parts of the drawing area. However, the single most important feature is probably the ability to make animations governed by mathematical formulas or data coming from physics simulations of the problem, as very simplistically shown in the example above.

9.4.2 Example of Classes for Geometric Objects

We shall now explain how we can, quite easily, realize software with the capabilities demonstrated in the previous examples. Each object in the figure is represented as a class in a class hierarchy. Using inheritance, classes can inherit properties from parent classes and add new geometric features.

We introduce class `Shape` as superclass for all specialized objects in a figure. This class does not store any data, but provides a series of functions that add functionality to all the subclasses. This will be shown later.

Simple Geometric Objects. One simple subclass is `Rectangle`, specified by the coordinates of the lower left corner and its width and height:

```

class Rectangle(Shape):
    def __init__(self, lower_left_corner, width, height):
        p = lower_left_corner # short form
        x = [p[0], p[0] + width,
             p[0] + width, p[0], p[0]]
        y = [p[1], p[1], p[1] + height,
             p[1] + height, p[1]]
        self.shapes = {'rectangle': Curve(x,y)}

```

Any subclass of `Shape` will have a constructor which takes geometric information about the shape of the object and creates a dictionary

`self.shapes` with the shape built of simpler shapes. The most fundamental shape is `Curve`, which is just a collection of (x, y) coordinates in two arrays `x` and `y`. Drawing the `Curve` object is a matter of plotting `y` versus `x`. For class `Rectangle` the `x` and `y` arrays contain the corner points of the rectangle in counterclockwise direction, starting and ending with in the lower left corner.

Class `Line` is also a simple class:

```
class Line(Shape):
    def __init__(self, start, end):
        x = [start[0], end[0]]
        y = [start[1], end[1]]
        self.shapes = {'line': Curve(x, y)}
```

Here we only need two points, the start and end point on the line. However, we may want to add some useful functionality, e.g., the ability to give an x coordinate and have the class calculate the corresponding y coordinate:

```
def __call__(self, x):
    """Given x, return y on the line."""
    x, y = self.shapes['line'].x, self.shapes['line'].y
    self.a = (y[1] - y[0]) / (x[1] - x[0])
    self.b = y[0] - self.a * x[0]
    return self.a * x + self.b
```

Unfortunately, this is too simplistic because vertical lines cannot be handled (infinite `self.a`). The true source code of `Line` therefore provides a more general solution at the cost of significantly longer code with more tests.

A circle implies a somewhat increased complexity. Again we represent the geometric object by a `Curve` object, but this time the `Curve` object needs to store a large number of points on the curve such that a plotting program produces a visually smooth curve. The points on the circle must be calculated manually in the constructor of class `Circle`. The formulas for points (x, y) on a curve with radius R and center at (x_0, y_0) are given by

$$\begin{aligned}x &= x_0 + R \cos(t), \\y &= y_0 + R \sin(t),\end{aligned}$$

where $t \in [0, 2\pi]$. A discrete set of t values in this interval gives the corresponding set of (x, y) coordinates on the circle. The user must specify the resolution as the number of t values. The circle's radius and center must of course also be specified.

We can write the `Circle` class as

```
class Circle(Shape):
    def __init__(self, center, radius, resolution=180):
        self.center, self.radius = center, radius
        self.resolution = resolution
```

```

t = linspace(0, 2*pi, resolution+1)
x0 = center[0]; y0 = center[1]
R = radius
x = x0 + R*cos(t)
y = y0 + R*sin(t)
self.shapes = {'circle': Curve(x, y)}

```

As in class `Line` we can offer the possibility to give an angle θ (equivalent to t in the formulas above) and then get the corresponding x and y coordinates:

```

def __call__(self, theta):
    """Return (x, y) point corresponding to angle theta."""
    return self.center[0] + self.radius*cos(theta), \
           self.center[1] + self.radius*sin(theta)

```

There is one flaw with this method: it yields illegal values after a translation, scaling, or rotation of the circle.

A part of a circle, an arc, is a frequent geometric object when drawing mechanical systems. The arc is constructed much like a circle, but t runs in $[\theta_s, \theta_s + \theta_a]$. Giving θ_s and θ_a the slightly more descriptive names `start_angle` and `arc_angle`, the code looks like this:

```

class Arc(Shape):
    def __init__(self, center, radius,
                 start_angle, arc_angle,
                 resolution=180):
        self.start_angle = radians(start_angle)
        self.arc_angle = radians(arc_angle)

        t = linspace(self.start_angle,
                     self.start_angle + self.arc_angle,
                     resolution+1)
        x0 = center[0]; y0 = center[1]
        R = radius
        x = x0 + R*cos(t)
        y = y0 + R*sin(t)
        self.shapes = {'arc': Curve(x, y)}

```

Having the `Arc` class, a `Circle` can alternatively be defined as a subclass specializing the arc to a circle:

```

class Circle(Arc):
    def __init__(self, center, radius, resolution=180):
        Arc.__init__(self, center, radius, 0, 360, resolution)

```

Class Curve. Class `Curve` sits on the coordinates to be drawn, but how is that done? The constructor of class `Curve` just stores the coordinates, while a method `draw` sends the coordinates to the plotting program to make a graph. Or more precisely, to avoid a lot of (e.g.) Matplotlib-specific plotting commands in class `Curve` we have created a small layer with a simple programming interface to plotting programs. This makes it straightforward to change from Matplotlib to another plotting program. The programming interface is represented by the `drawing_tool` object and has a few functions:

- `plot_curve` for sending a curve in terms of x and y coordinates to the plotting program,
- `set_coordinate_system` for specifying the graphics area,
- `erase` for deleting all elements of the graph,
- `set_grid` for turning on a grid (convenient while constructing the figure),
- `set_instruction_file` for creating a separate file with all plotting commands (Matplotlib commands in our case),
- a series of `set_X` functions where X is some property like `linecolor`, `linestyle`, `linewidth`, `filled_curves`.

This is basically all we need to communicate to a plotting program.

Any class in the `Shape` hierarchy inherits `set_X` functions for setting properties of curves. This information is propagated to all other shape objects in the `self.shapes` dictionary. Class `Curve` stores the line properties together with the coordinates of its curve and propagates this information to the plotting program. When saying `vehicle.set_linewidth(10)`, all objects that make up the `vehicle` object will get a `set_linewidth(10)` call, but only the `Curve` object at the end of the chain will actually store the information and send it to the plotting program.

A rough sketch of class `Curve` reads

```
class Curve(Shape):
    """General curve as a sequence of (x,y) coordinates."""
    def __init__(self, x, y):
        self.x = asarray(x, dtype=float)
        self.y = asarray(y, dtype=float)

    def draw(self):
        drawing_tool.plot_curve(
            self.x, self.y,
            self.linestyle, self.linewidth, self.linecolor, ...)

    def set_linewidth(self, width):
        self.linewidth = width

    def set_linestyle(self, style):
        self.linestyle = style
    ...
```

Compound Geometric Objects. The simple classes `Line`, `Arc`, and `Circle` could can the geometric shape through just one `Curve` object. More complicated shapes are built from instances of various subclasses of `Shape`. Classes used for professional drawings soon get quite complex in composition and have a lot of geometric details, so here we prefer to make a very simple composition: the already drawn vehicle from Figure 9.7. That is, instead of composing the drawing in a Python program as shown above, we make a subclass `Vehicle0` in the `Shape` hierarchy for doing the same thing.

The `Shape` hierarchy is found in the `pysketcher` package, so to use these classes or derive a new one, we need to import `pysketcher`. The

constructor of class `Vehicle0` performs approximately the same statements as in the example program we developed for making the drawing in Figure 9.7.

```
from pysketcher import *

class Vehicle0(Shape):
    def __init__(self, w_1, R, L, H):
        wheel1 = Circle(center=(w_1, R), radius=R)
        wheel2 = wheel1.copy()
        wheel2.translate((L,0))

        under = Rectangle(lower_left_corner=(w_1-2*R, 2*R),
                          width=2*R + L + 2*R, height=H)
        over = Rectangle(lower_left_corner=(w_1, 2*R + H),
                        width=2.5*R, height=1.25*H)

        wheels = Composition(
            {'wheel1': wheel1, 'wheel2': wheel2})
        body = Composition(
            {'under': under, 'over': over})

        vehicle = Composition({'wheels': wheels, 'body': body})
        xmax = w_1 + 2*L + 3*R
        ground = Wall(x=[R, xmax], y=[0, 0], thickness=-0.3*R)

        self.shapes = {'vehicle': vehicle, 'ground': ground}
```

Any subclass of `Shape` *must* define the `shapes` attribute, otherwise the inherited `draw` method (and a lot of other methods too) will not work.

The painting of the vehicle, as shown in the right part of Figure 9.10, could in class `Vehicle0` be offered by a method:

```
def colorful(self):
    wheels = self.shapes['vehicle']['wheels']
    wheels.set_filled_curves('blue')
    wheels.set_linewidth(6)
    wheels.set_linecolor('black')
    under = self.shapes['vehicle']['body']['under']
    under.set_filled_curves('red')
    over = self.shapes['vehicle']['body']['over']
    over.set_filled_curves(pattern='/')
    over.set_linewidth(14)
```

The usage of the class is simple: after having set up an appropriate coordinate system as previously shown, we can do

```
vehicle = Vehicle0(w_1, R, L, H)
vehicle.draw()
drawing_tool.display()
```

and go on to make a painted version by

```
drawing_tool.erase()
vehicle.colorful()
vehicle.draw()
drawing_tool.display()
```

A complete code defining and using class `Vehicle0` is found in the file `vehicle2.py`.

The `pysketcher` package contains a wide range of classes for various geometrical objects, particularly those that are frequently used in drawings of mechanical systems.

9.4.3 Adding Functionality via Recursion

The really powerful feature of our class hierarchy is that we can add much functionality to the superclass `Shape` and to the “bottom” class `Curve`, and then all other classes for various types of geometrical shapes immediately get the new functionality. To explain the idea we may look at the `draw` method, which all classes in the `Shape` hierarchy must have. The inner workings of the `draw` method explain the secrets of how a series of other useful operations on figures can be implemented.

Basic Principles of Recursion. Note that we work with two types of hierarchies in the present documentation: one Python *class hierarchy*, with `Shape` as superclass, and one *object hierarchy* of figure elements in a specific figure. A subclass of `Shape` stores its figure in the `self.shapes` dictionary. This dictionary represents the object hierarchy of figure elements for that class. We want to make one `draw` call for an instance, say our class `Vehicle0`, and then we want this call to be propagated to *all* objects that are contained in `self.shapes` and all its nested subdictionaries. How is this done?

The natural starting point is to call `draw` for each `Shape` object in the `self.shapes` dictionary:

```
def draw(self):
    for shape in self.shapes:
        self.shapes[shape].draw()
```

This general method can be provided by class `Shape` and inherited in subclasses like `Vehicle0`. Let `v` be a `Vehicle0` instance. Seemingly, a call `v.draw()` just calls

```
v.shapes['vehicle'].draw()
v.shapes['ground'].draw()
```

However, in the former call we call the `draw` method of a `Composition` object whose `self.shapes` attributed has two elements: `wheels` and `body`. Since class `Composition` inherits the same `draw` method, this method will run through `self.shapes` and call `wheels.draw()` and `body.draw()`. Now, the `wheels` object is also a `Composition` with the same `draw` method, which will run through `self.shapes`, now containing the `wheel1` and `wheel2` objects. The `wheel1` object is a `Circle`, so calling `wheel1.draw()` calls the `draw` method in class `Circle`, but this is the same `draw` method as shown above. This method will therefore

traverse the circle's `shapes` dictionary, which we have seen consists of one `Curve` element.

The `Curve` object holds the coordinates to be plotted so here `draw` really needs to do something “physical”, namely send the coordinates to the plotting program. The `draw` method is outlined in the short listing of class `Curve` shown previously.

We can go to any of the other shape objects that appear in the figure hierarchy and follow their `draw` calls in the similar way. Every time, a `draw` call will invoke a new `draw` call, until we eventually hit a `Curve` object in the “bottom” of the figure hierarchy, and then that part of the figure is really plotted (or more precisely, the coordinates are sent to a plotting program).

When a method calls itself, such as `draw` does, the calls are known as *recursive* and the programming principle is referred to as *recursion*. This technique is very often used to traverse hierarchical structures like the figure structures we work with here. Even though the hierarchy of objects building up a figure are of different types, they all inherit the same `draw` method and therefore exhibit the same behavior with respect to drawing. Only the `Curve` object has a different `draw` method, which does not lead to more recursion.

Explaining Recursion. Understanding recursion is usually a challenge. To get a better idea of how recursion works, we have equipped class `Shape` with a method `recurse` which just visits all the objects in the `shapes` dictionary and prints out a message for each object. This feature allows us to trace the execution and see exactly where we are in the hierarchy and which objects that are visited.

The `recurse` method is very similar to `draw`:

```
def recurse(self, name, indent=0):
    # print message where we are (name is where we come from)
    for shape in self.shapes:
        # print message about which object to visit
        self.shapes[shape].recurse(indent+2, shape)
```

The `indent` parameter governs how much the message from this `recurse` method is intended. We increase `indent` by 2 for every level in the hierarchy, i.e., every row of objects in Figure 9.12. This indentation makes it easy to see on the printout how far down in the hierarchy we are.

A typical message written by `recurse` when `name` is `'body'` and the `shapes` dictionary has the keys `'over'` and `'under'`, will be

```
Composition: body.shapes has entries 'over', 'under'
call body.shapes["over"].recurse("over", 6)
```

The number of leading blanks on each line corresponds to the value of `indent`. The code printing out such messages looks like

```

def recurse(self, name, indent=0):
    space = ' '*indent
    print space, '%s: %s.shapes has entries' % \
        (self.__class__.__name__, name), \
        str(list(self.shapes.keys()))[1:-1]

    for shape in self.shapes:
        print space,
        print 'call %s.shapes["%s"].recurse("%s", %d)' % \
            (name, shape, shape, indent+2)
        self.shapes[shape].recurse(shape, indent+2)

```

Let us follow a `v.recurse('vehicle')` call in detail, `v` being a `Vehicle0` instance. Before looking into the output from `recurse`, let us get an overview of the figure hierarchy in the `v` object (as produced by `print v`)

```

ground
  wall
  vehicle
    body
      over
        rectangle
      under
        rectangle
    wheels
      wheel1
        arc
      wheel2
        arc

```

The `recurse` method performs the same kind of traversal of the hierarchy, but writes out and explains a lot more.

The data structure represented by `v.shapes` is known as a *tree*. As in physical trees, there is a *root*, here the `v.shapes` dictionary. A graphical illustration of the tree (upside down) is shown in Figure 9.12. From the root there are one or more branches, here two: `ground` and `vehicle`. Following the `vehicle` branch, it has two new branches, `body` and `wheels`. Relationships as in family trees are often used to describe the relations in object trees too: we say that `vehicle` is the parent of `body` and that `body` is a child of `vehicle`. The term *node* is also often used to describe an element in a tree. A node may have several other nodes as *descendants*.

Recursion is the principal programming technique to traverse tree structures. Any object in the tree can be viewed as a root of a subtree. For example, `wheels` is the root of a subtree that branches into `wheel1` and `wheel2`. So when processing an object in the tree, we imagine we process the root and then recurse into a subtree, but the first object we recurse into can be viewed as the root of the subtree, so the processing procedure of the parent object can be repeated.

A recommended next step is to simulate the `recurse` method by hand and carefully check that what happens in the visits to `recurse` is consistent with the output listed below. Although tedious, this is a major exercise that guaranteed will help to demystify recursion.

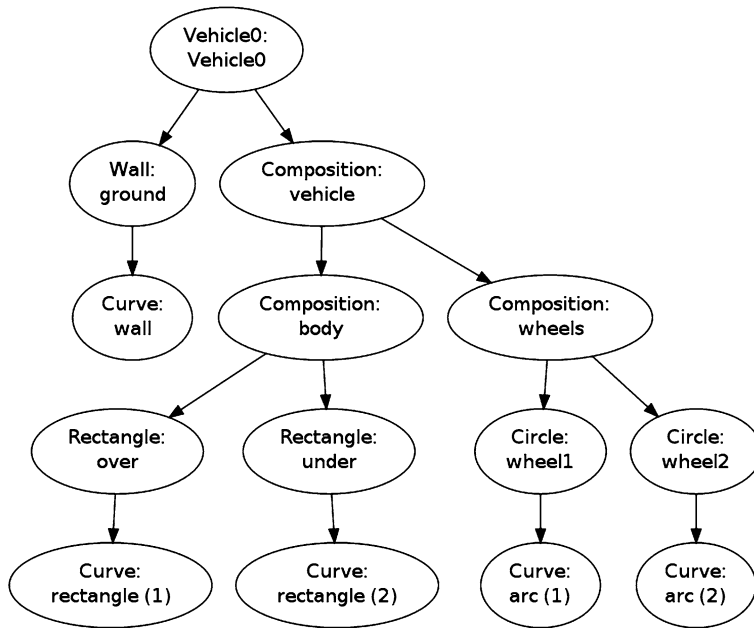

Fig. 9.12 Hierarchy of figure elements in an instance of class Vehicle0.

A part of the printout of `v.recurse('vehicle')` looks like

```

Vehicle0: vehicle.shapes has entries 'ground', 'vehicle'
call vehicle.shapes["ground"].recurse("ground", 2)
  Wall: ground.shapes has entries 'wall'
  call ground.shapes["wall"].recurse("wall", 4)
  reached "bottom" object Curve
call vehicle.shapes["vehicle"].recurse("vehicle", 2)
  Composition: vehicle.shapes has entries 'body', 'wheels'
  call vehicle.shapes["body"].recurse("body", 4)
  Composition: body.shapes has entries 'over', 'under'
  call body.shapes["over"].recurse("over", 6)
  Rectangle: over.shapes has entries 'rectangle'
  call over.shapes["rectangle"].recurse("rectangle", 8)
  reached "bottom" object Curve
  call body.shapes["under"].recurse("under", 6)
  Rectangle: under.shapes has entries 'rectangle'
  call under.shapes["rectangle"].recurse("rectangle", 8)
  reached "bottom" object Curve
...

```

This example should clearly demonstrate the principle that we can start at any object in the tree and do a recursive set of calls with that object as root.

9.4.4 Scaling, Translating, and Rotating a Figure

With recursion, as explained in the previous section, we can within minutes equip *all* classes in the Shape hierarchy, both present and future ones, with the ability to scale the figure, translate it, or rotate it. This added functionality requires only a few lines of code.

Scaling. We start with the simplest of the three geometric transformations, namely scaling. For a Curve instance containing a set of n

coordinates (x_i, y_i) that make up a curve, scaling by a factor a means that we multiply all the x and y coordinates by a :

$$x_i \leftarrow ax_i, \quad y_i \leftarrow ay_i, \quad i = 0, \dots, n - 1.$$

Here we apply the arrow as an assignment operator. The corresponding Python implementation in class `Curve` reads

```
class Curve:
    ...
    def scale(self, factor):
        self.x = factor*self.x
        self.y = factor*self.y
```

Note here that `self.x` and `self.y` are Numerical Python arrays, so that multiplication by a scalar number `factor` is a vectorized operation.

An even more efficient implementation is to make use of in-place multiplication in the arrays,

```
class Curve:
    ...
    def scale(self, factor):
        self.x *= factor
        self.y *= factor
```

as this saves the creation of temporary arrays like `factor*self.x`.

In an instance of a subclass of `Shape`, the meaning of a method `scale` is to run through all objects in the dictionary `shapes` and ask each object to scale itself. This is the same delegation of actions to subclass instances as we do in the `draw` (or `recurse`) method. All objects, except `Curve` instances, can share the same implementation of the `scale` method. Therefore, we place the `scale` method in the superclass `Shape` such that all subclasses inherit the method. Since `scale` and `draw` are so similar, we can easily implement the `scale` method in class `Shape` by copying and editing the `draw` method:

```
class Shape:
    ...
    def scale(self, factor):
        for shape in self.shapes:
            self.shapes[shape].scale(factor)
```

This is all we have to do in order to equip all subclasses of `Shape` with scaling functionality! Any piece of the figure will scale itself, in the same manner as it can draw itself.

Translation. A set of coordinates (x_i, y_i) can be translated v_0 units in the x direction and v_1 units in the y direction using the formulas

$$x_i \leftarrow x_i + v_0, \quad y_i \leftarrow y_i + v_1, \quad i = 0, \dots, n - 1.$$

The natural specification of the translation is in terms of the vector $v = (v_0, v_1)$. The corresponding Python implementation in class `Curve` becomes

```
class Curve:
    ...
    def translate(self, v):
        self.x += v[0]
        self.y += v[1]
```

The translation operation for a shape object is very similar to the scaling and drawing operations. This means that we can implement a common method `translate` in the superclass `Shape`. The code is parallel to the `scale` method:

```
class Shape:
    ....
    def translate(self, v):
        for shape in self.shapes:
            self.shapes[shape].translate(v)
```

Rotation. Rotating a figure is more complicated than scaling and translating. A counter clockwise rotation of θ degrees for a set of coordinates (x_i, y_i) is given by

$$\begin{aligned}\bar{x}_i &\leftarrow x_i \cos \theta - y_i \sin \theta, \\ \bar{y}_i &\leftarrow x_i \sin \theta + y_i \cos \theta.\end{aligned}$$

This rotation is performed around the origin. If we want the figure to be rotated with respect to a general point (x, y) , we need to extend the formulas above:

$$\begin{aligned}\bar{x}_i &\leftarrow x + (x_i - x) \cos \theta - (y_i - y) \sin \theta, \\ \bar{y}_i &\leftarrow y + (x_i - x) \sin \theta + (y_i - y) \cos \theta.\end{aligned}$$

The Python implementation in class `Curve`, assuming that θ is given in degrees and not in radians, becomes

```
def rotate(self, angle, center):
    angle = radians(angle)
    x, y = center
    c = cos(angle); s = sin(angle)
    xnew = x + (self.x - x)*c - (self.y - y)*s
    ynew = y + (self.x - x)*s + (self.y - y)*c
    self.x = xnew
    self.y = ynew
```

The `rotate` method in class `Shape` follows the principle of the `draw`, `scale`, and `translate` methods.

We have already seen the `rotate` method in action when animating the rolling wheel at the end of Chapter 9.4.1.

9.5 Classes for DNA Analysis

We shall here exemplify the use of classes for performing DNA analysis as explained in Chapters 3.3.1, 6.6.1, 6.6.2, 6.6.3, 6.6.4, 6.6.5, and 8.3.4. Basically, we create a class `Gene` to represent a DNA sequence (string) and a class `Region` to represent a subsequence (substring), typically an exon or intron.

9.5.1 Class for Regions

The class for representing a region of a DNA string is quite simple:

```
class Region:
    def __init__(self, dna, start, end):
        self._region = dna[start:end]

    def get_region(self):
        return self._region

    def __len__(self):
        return len(self._region)

    def __eq__(self, other):
        """Check if two Region instances are equal."""
        return self._region == other._region

    def __add__(self, other):
        """Add Region instances: self + other"""
        return self._region + other._region

    def __iadd__(self, other):
        """Increment Region instance: self += other"""
        self._region += other._region
        return self
```

Besides storing the substring and giving access to it through `get_region`, we have also included the possibility to

- say `len(r)` if `r` is a `Region` instance
- check if two `Region` instances are equal
- write `r1 + r2` for two instances `r1` and `r2` of type `Region`
- perform `r1 += r2`

The latter two operations are convenient for making one large string out of all exon or intron regions.

9.5.2 Class for Genes

The class for gene will be longer and more complex than class `Region`. We already have a bunch of functions performing various types of analysis. The idea of the `Gene` class is that these functions are methods in the class operating on the DNA string and the exon regions stored in the class. Rather than recoding all the functions as methods in the class we

shall just let the class “wrap” the functions. That is, the class methods call up the functions we already have. This approach has two advantages: users can either choose the function-based or the class-based interface, and the programmer can reuse all the ready-made functions when implementing the class-based interface.

The selection of functions include

- `generate_string` for generating a random string from some alphabet
- `download` and `read_dnafile` (version `read_dnafile_v1`) for downloading data from the Internet and reading from file
- `read_exon_regions` (version `read_exon_regions_v2`) for reading exon regions from file
- `tofile_with_line_sep` (version `tofile_with_line_sep_v2`) for writing strings to file
- `read_genetic_code` (version `read_genetic_code_v2`) for loading the mapping from triplet codes to 1-letter symbols for amino acids
- `get_base_frequencies` (version `get_base_frequencies_v2`) for finding frequencies of each base
- `format_frequencies` for formatting base frequencies with two decimals
- `create_mRNA` for computing an mRNA string from DNA and exon regions
- `mutate` for mutating a base at a random position
- `create_markov_chain`, `transition`, and `mutate_via_markov_chain` for mutating a base at a random position according to randomly generated transition probabilities
- `create_protein_fixed` for proper creation of a protein sequence (string)

The set of plain functions for DNA analysis is found in the file `dna_functions.py`, while `dna_classes.py` contains the implementations of classes `Gene` and `Region`.

Basic Features of class Gene. Class `Gene` is supposed to hold the DNA sequence and the associated exon regions. A simple constructor expects the exon regions to be specified as a list of (start, end) tuples indicating the start and end of each region:

```
class Gene:
    def __init__(self, dna, exon_regions):
        self._dna = dna

        self._exon_regions = exon_regions
        self._exons = []
        for start, end in exon_regions:
            self._exons.append(Region(dna, start, end))

        # Compute the introns (regions between the exons)
        self._introns = []
        prev_end = 0
        for start, end in exon_regions:
```

```

        self._introns.append(Region(dna, prev_end, start))
        prev_end = end
        self._introns.append(Region(dna, end, len(dna)))

```

The methods in class `Gene` are trivial to implement when we already have the functionality in stand-alone functions. Here are a few examples on methods:

```

from dna_functions import *

class Gene:
    ...

    def write(self, filename, chars_per_line=70):
        """Write DNA sequence to file with name filename."""
        tofile_with_line_sep(self._dna, filename, chars_per_line)

    def count(self, base):
        """Return no of occurrences of base in DNA."""
        return self._dna.count(base)

    def get_base_frequencies(self):
        """Return dict of base frequencies in DNA."""
        return get_base_frequencies(self._dna)

    def format_base_frequencies(self):
        """Return base frequencies formatted with two decimals."""
        return format_frequencies(self.get_base_frequencies())

```

Flexible Constructor. The constructor can be made more flexible. First, the exon regions may not be known so we should allow `None` as value and in fact use that as default value. Second, exon regions at the start and/or end of the DNA string will lead to empty intron `Region` objects so a proper test on nonzero length of the introns must be inserted. Third, the data for the DNA string and the exon regions can either be passed as arguments or downloaded and read from file. Two different initializations of `Gene` objects are therefore

```

g1 = Gene(dna, exon_regions) # user has read data from file
g2 = Gene((urlbase, dna_file), (urlbase, exon_file)) # download

```

One can pass `None` for `urlbase` if the files are already at the computer. The flexible constructor has, not surprisingly, much longer code than the first version. The implementation illustrates well how the concept of overloaded constructors in other languages, like C++ and Java, are dealt with in Python (overloaded constructors take different types of arguments to initialize an instance):

```

class Gene:
    def __init__(self, dna, exon_regions):
        """
        dna: string or (urlbase,filename) tuple
        exon_regions: None, list of (start,end) tuples
                    or (urlbase,filename) tuple
        In case of (urlbase,filename) tuple the file
        is downloaded and read.
        """

```

```

if isinstance(dna, (list,tuple)) and \
len(dna) == 2 and isinstance(dna[0], str) and \
isinstance(dna[1], str):
    download(urlbase=dna[0], filename=dna[1])
    dna = read_dnafile(dna[1])
elif isinstance(dna, str):
    pass # ok type (the other possibility)
else:
    raise TypeError(
        'dna=%s %s is not string or (urlbase,filename) '\
        'tuple' % (dna, type(dna)))

self._dna = dna

er = exon_regions
if er is None:
    self._exons = None
    self._introns = None
else:
    if isinstance(er, (list,tuple)) and \
len(er) == 2 and isinstance(er[0], str) and \
isinstance(er[1], str):
        download(urlbase=er[0], filename=er[1])
        exon_regions = read_exon_regions(er[1])
    elif isinstance(er, (list,tuple)) and \
isinstance(er[0], (list,tuple)) and \
isinstance(er[0][0], int) and \
isinstance(er[0][1], int):
        pass # ok type (the other possibility)
    else:
        raise TypeError(
            'exon_regions=%s %s is not list of (int,int) '\
            'or (urlbase,filename) tuple' % (er, type(era)))

self._exon_regions = exon_regions
self._exons = []
for start, end in exon_regions:
    self._exons.append(Region(dna, start, end))

# Compute the introns (regions between the exons)
self._introns = []
prev_end = 0
for start, end in exon_regions:
    if start - prev_end > 0:
        self._introns.append(
            Region(dna, prev_end, start))
    prev_end = end
if len(dna) - end > 0:
    self._introns.append(Region(dna, end, len(dna)))

```

Note that we perform quite detailed testing of the object type of the data structures supplied as the `dna` and `exon_regions` arguments. This can well be done to ensure safe use also when there is only one allowed type per argument.

Other Methods. A `create_mRNA` method, returning the mRNA as a string, can be coded as

```

def create_mRNA(self):
    """Return string for mRNA."""
    if self._exons is not None:
        return create_mRNA(self._dna, self._exon_regions)
    else:

```

```

        raise ValueError(
            'Cannot create mRNA for gene with no exon regions')

```

Also here we rely on calling an already implemented function, but include some testing whether asking for mRNA is appropriate.

Methods for creating a mutated gene are also included:

```

def mutate_pos(self, pos, base):
    """Return Gene with a mutation to base at position pos."""
    dna = self._dna[:pos] + base + self._dna[pos+1:]
    return Gene(dna, self._exon_regions)

def mutate_random(self, n=1):
    """
    Return Gene with n mutations at a random position.
    All mutations are equally probable.
    """
    mutated_dna = self._dna
    for i in range(n):
        mutated_dna = mutate(mutated_dna)
    return Gene(mutated_dna, self._exon_regions)

def mutate_via_markov_chain(markov_chain):
    """
    Return Gene with a mutation at a random position.
    Mutation into new base based on transition
    probabilities in the markov_chain dict of dicts.
    """
    mutated_dna = mutate_via_markov_chain(
        self._dna, markov_chain)
    return Gene(mutated_dna, self._exon_regions)

```

Some “get” methods that give access to the fundamental attributes of the class can be included:

```

def get_dna(self):
    return self._dna

def get_exons(self):
    return self._exons

def get_introns(self):
    return self._introns

```

Alternatively, one could access the attributes directly: `gene._dna`, `gene._exons`, etc. In that case we should remove the leading underscore as this underscore signals that these attributes are considered “protected”, i.e., not to be directly accessed by the user. The “protection” in “get” functions is more mental than actual since we anyway give the data structures in the hands of the user and she can do whatever she wants (even delete them).

Special methods for the length of a gene, adding genes, checking if two genes are identical, and printing of compact gene information are relevant to add:

```

def __len__(self):
    return len(self._dna)

```

```

def __add__(self, other):
    """self + other: append other to self (DNA string)."""
    if self._exons is None and other._exons is None:
        return Gene(self._dna + other._dna, None)
    else:
        raise ValueError(
            'cannot do Gene + Gene with exon regions')

def __iadd__(self, other):
    """self += other: append other to self (DNA string)."""
    if self._exons is None and other._exons is None:
        self._dna += other._dna
        return self
    else:
        raise ValueError(
            'cannot do Gene += Gene with exon regions')

def __eq__(self, other):
    """Check if two Gene instances are equal."""
    return self._dna == other._dna and \
           self._exons == other._exons

def __str__(self):
    """Pretty print (condensed info)."""
    s = 'Gene: ' + self._dna[:6] + '...' + self._dna[-6:] + \
        ', length=%d' % len(self._dna)
    if self._exons is not None:
        s += ', %d exon regions' % len(self._exons)
    return s

```

Here is an interactive session demonstrating how we can work with class Gene objects:

```

>>> from dna_classes import Gene
>>> g1 = Gene('ATCCGTAATTGCGCA', [(2,4), (6,9)])
>>> print g1
Gene: ATCCGT...TGCGCA, length=15, 2 exon regions
>>> g2 = g1.mutate_random(10)
>>> print g2
Gene: ATCCGT...TGTGCT, length=15, 2 exon regions
>>> g1 == g2
False
>>> g1 += g2 # expect exception
Traceback (most recent call last):
...
ValueError: cannot do Gene += Gene with exon regions
>>> g1b = Gene(g1.get_dna(), None)
>>> g2b = Gene(g2.get_dna(), None)
>>> print g1b
Gene: ATCCGT...TGCGCA, length=15
>>> g3 = g1b + g2b
>>> g3.format_base_frequencies()
'A: 0.17, C: 0.23, T: 0.33, G: 0.27'

```

9.5.3 Subclasses

There are two fundamental types of genes: the most common type which codes for proteins (indirectly via mRNA) and the type which only codes for RNA (without being further processed to proteins). The product of a gene, mRNA or protein, depends on the type of gene we have. It is then natural to create two subclasses for the two types of

gene and have a method `get_product` which returns the product of that type of gene.

The `get_product` method can be declared in class `Gene`:

```
def get_product(self):
    raise NotImplementedError(
        'Subclass %s must implement get_product' % \
        self.__class__.__name__)
```

The exception here will be triggered by an instance (`self`) of any subclass that just inherits `get_product` from class `Gene` without implementing a subclass version of this method.

The two subclasses of `Gene` may take this simple form:

```
class RNACodingGene(Gene):
    def get_product(self):
        return self.create_mRNA()

class ProteinCodingGene(Gene):
    def __init__(self, dna, exon_positions):
        Gene.__init__(self, dna, exon_positions)
        urlbase = 'http://hplgit.github.com/bioinf-py/data/'
        genetic_code_file = 'genetic_code.tsv'
        download(urlbase, genetic_code_file)
        code = read_genetic_code(genetic_code_file)
        self.genetic_code = code

    def get_product(self):
        return create_protein_fixed(self.create_mRNA(),
                                    self.genetic_code)
```

A demonstration of how to load the lactase gene and create the lactase protein is done with

```
def _test():
    urlbase = 'http://hplgit.github.com/bioinf-py/data/'
    lactase_gene_file = 'lactase_gene.txt'
    lactase_exon_file = 'lactase_exon.tsv'
    lactase_gene = ProteinCodingGene(
        (urlbase, lactase_gene_file),
        (urlbase, lactase_exon_file))

    protein = lactase_gene.get_product()
    tofile_with_line_sep(protein, 'output', 'lactase_protein.txt')
```

Now, envision that the Lactase gene would instead have been an RNA-coding gene. The only necessary changes would have been to exchange `ProteinCodingGene` by `RNACodingGene` in the assignment to `lactase_gene`, and one would get out a final RNA product instead of a protein.

Acknowledgments. The bioinformatics examples in Chapters 3.3, 6.6, 8.3.4, and 9.5 were prepared by Geir Kjetil Sandve with help from Sveinung Gundersen, Ksenia Khelik, Halfdan Rydbeck, and Kai Trengerid.

9.6 Summary

9.6.1 Chapter Topics

A subclass inherits everything from its superclass, both attributes and methods. The subclass can add new attributes, overload methods, and thereby enrich or restrict functionality of the superclass.

Subclass Example. Consider class `Gravity` from Chapter 7.7.1 for representing the gravity force GMm/r^2 between two masses m and M being a distance r apart. Suppose we want to make a class for the electric force between two charges q_1 and q_2 , being a distance r apart in a medium with permittivity ϵ_0 is Gq_1q_2/r^2 , where $G^{-1} = 4\pi\epsilon_0$. We use the approximate value $G = 8.99 \cdot 10^9 \text{ Nm}^2/\text{C}^2$ (C is the Coulomb unit used to measure electric charges such as q_1 and q_2). Since the electric force is similar to the gravity force, we can easily implement the electric force as a subclass of `Gravity`. The implementation just needs to redefine the value of G !

```
class CoulombsLaw(Gravity):
    def __init__(self, q1, q2):
        Gravity.__init__(self, q1, q2)
        self.G = 8.99E9
```

We can now call the inherited `force(r)` method to compute the electric force and the `visualize` method to make a plot of the force:

```
c = CoulombsLaw(1E-6, -2E-6)
print 'Electric force:', c.force(0.1)
c.visualize(0.01, 0.2)
```

However, the `plot` method inherited from class `Gravity` has an inappropriate title referring to “Gravity force” and the masses m and M . An easy fix could be to have the plot title as an attribute set in the constructor. The subclass can then override the contents of this attribute, as it overrides `self.G`. It is quite common to discover that a class needs adjustments if it is to be used as superclass.

Subclassing in General. The typical sketch of creating a subclass goes as follows:

```
class SuperClass:
    def __init__(self, p, q):
        self.p, self.q = p, q

    def where(self):
        print 'In superclass', self.__class__.__name__

    def compute(self, x):
        self.where()
        return self.p*x + self.q
```

```

class SubClass(SuperClass):
    def __init__(self, p, q, a):
        SuperClass.__init__(self, p, q)
        self.a = a

    def where(self):
        print 'In subclass', self.__class__.__name__

    def compute(self, x):
        self.where()
        return SuperClass.compute(self, x) + self.a*x**2

```

This example shows how a subclass extends a superclass with one attribute (`a`). The subclass' `compute` method calls the corresponding superclass method, as well as the overloaded method `where`. Let us invoke the `compute` method through superclass and subclass instances:

```

>>> super = SuperClass(1, 2)
>>> sub = SubClass(1, 2, 3)
>>> v1 = super.compute(0)
In superclass SuperClass
>>> v2 = sub.compute(0)
In subclass SubClass
In subclass SubClass

```

Observe that in the subclass `sub`, method `compute` calls `self.where`, which translates to the `where` method in `SubClass`. Then the `compute` method in `SuperClass` is invoked, and this method also makes a `self.where` call, which is a call to `SubClass`' `where` method (think of what `self` is here, it is `sub`, so it is natural that we get `where` in the subclass (`sub.where`) and not `where` in the superclass part of `sub`).

In this example, classes `SuperClass` and `SubClass` constitute a class hierarchy. Class `SubClass` inherits the attributes `p` and `q` from its superclass, and overrides the methods `where` and `compute`.

9.6.2 Example: Input Data Reader

The summarizing example of this chapter concerns a class hierarchy for simplifying reading input data into programs. Input data may come from several different sources: the command line, a file, or from a dialog with the user, either of `input` form or in a graphical user interface (GUI). Therefore it makes sense to create a class hierarchy where subclasses are specialized to read from different sources and where the common code is placed in a superclass. The resulting tool will make it easy for you to let your programs read from many different input sources by adding just a few lines.

Problem. Let us motivate the problem by a case where we want to write a program for dumping n function values of $f(x)$ to a file for $x \in [a, b]$. The core part of the program typically reads

```
outfile = open(filename, 'w')
import numpy as np
for x in np.linspace(a, b, n):
    outfile.write('%12g %12g\n' % (x, f(x)))
outfile.close()
```

Our purpose is to read data into the variables `a`, `b`, `n`, `filename`, and `f`. For the latter we want to specify a formula and use the `StringFunction` tool (Chapter 4.1.4) to make the function `f`:

```
from scitools.StringFunction import StringFunction
f = StringFunction(formula)
```

How can we read `a`, `b`, `n`, `formula`, and `filename` conveniently into the program?

The basic idea is that we place the input data in a dictionary, and create a tool that can update this dictionary from sources like the command line, a file, a GUI, etc. Our dictionary is then

```
p = dict(formula='x+1', a=0, b=1, n=2, filename='tmp.dat')
```

This dictionary specifies the names of the input parameters to the program and the default values of these parameters.

Using the tool is a matter of feeding `p` into the constructor of a subclass in the tools' class hierarchy and extract the parameters into, for example, distinct variables:

```
inp = Subclassname(p)
a, b, filename, formula, n = inp.get_all()
```

Depending on what we write as `Subclassname`, the five variables can be read from the command line, the terminal window, a file, or a GUI. The task now is to implement a class hierarchy to facilitate the described flexible reading of input data.

Solution. We first create a very simple superclass `ReadInput`. Its main purpose is to store the parameter dictionary as an attribute, provide a method `get` to extract single values, and a method `get_all` to extract all parameters into distinct variables:

```
class ReadInput:
    def __init__(self, parameters):
        self.p = parameters

    def get(self, parameter_name):
        return self.p[parameter_name]

    def get_all(self):
        return [self.p[name] for name in sorted(self.p)]

    def __str__(self):
        import pprint
        return pprint.pformat(self.p)
```

Note that we in the `get_all` method must sort the keys in `self.p` such that the list of returned variables is well defined. In the calling program we can then list variables in the same order as the alphabetic order of the parameter names, for example:

```
a, b, filename, formula, n = inp.get_all()
```

The `__str__` method applies the `pprint` module to get a pretty print of all the parameter names and their values.

Class `ReadInput` cannot read from any source – subclasses are supposed to do this. The forthcoming text describes various types of subclasses for various types of reading input.

Prompting the User. The perhaps simplest way of getting data into a program is to use `raw_input`. We then prompt the user with a text Give name: and get an appropriate object back (recall that strings must be enclosed in quotes). The subclass `PromptUser` for doing this then reads

```
class PromptUser(ReadInput):
    def __init__(self, parameters):
        ReadInput.__init__(self, parameters)
        self._prompt_user()

    def _prompt_user(self):
        for name in self.p:
            self.p[name] = eval(raw_input("Give " + name + ": "))
```

Note the underscore in `_prompt_user`: the underscore signifies that this is a “private” method in the `PromptUser` class, not intended to be called by users of the class.

There is a major difficulty with using `eval` on the input from the user. When the input is intended to be a string object, such as a filename, say `tmp.inp`, the program will perform the operation `eval(tmp.inp)`, which leads to an exception because `tmp.inp` is treated as a variable `inp` in a module `tmp` and not as the string `'tmp.inp'`. To solve this problem, we use the `str2obj` function from the `scitools.misc` module. This function will return the right Python object also in the case where the argument should result in a string object (see Chapter 4.6.1 for some information about `str2obj`). The bottom line is that `str2obj` acts as a safer `eval(raw_input(...))` call. The key assignment in class `PromptUser` is then changed to

```
self.p[name] = str2obj(raw_input("Give " + name + ": "))
```

Reading from File. We can also place `name = value` commands in a file and load this information into the dictionary `self.p`. An example of a file can be

```

formula = sin(x) + cos(x)
filename = tmp.dat
a = 0
b = 1

```

In this example we have omitted `n`, so we rely on its default value.

A problem is how to give the filename. The easy way out of this problem is to read from standard input, and just redirect standard input from a file when we run the program. For example, if the filename is `tmp.inp`, we run the program as follows in a terminal window⁶

```

Terminal
Terminal> python myprog.py < tmp.inp

```

To interpret the contents of the file, we read line by line, split each line with respect to `=`, use the left-hand side as the parameter name and the right-hand side as the corresponding value. It is important to strip away unnecessary blanks in the name and value. The complete class now reads

```

class ReadInputFile(ReadInput):
    def __init__(self, parameters):
        ReadInput.__init__(self, parameters)
        self._read_file()

    def _read_file(self, infile=sys.stdin):
        for line in infile:
            if "=" in line:
                name, value = line.split("=")
                self.p[name.strip()] = str2obj(value.strip())

```

A nice feature with reading from standard input is that if we do not redirect standard input to a file, the program will prompt the user in the terminal window, where the user can give commands of the type `name = value` for setting selected input data. A `Ctrl-D` is needed to terminate the interactive session in the terminal window and continue execution of the program.

Reading from the Command Line. For input from the command line we assume that parameters and values are given as option-value pairs, e.g., as in

```
--a 1 --b 10 --n 101 --formula "sin(x) + cos(x)"
```

We apply the `argparse` module (Chapter 4.2.4) to parse the command-line arguments. The list of legal option names must be constructed from the list of keys in the `self.p` dictionary. The complete class takes the form

⁶ The redirection of standard input from a file does not work in IPython so we are in this case forced to run the program in a terminal window.

```

class ReadCommandLine(ReadInput):
    def __init__(self, parameters):
        self.sys_argv = sys.argv[1:] # copy
        ReadInput.__init__(self, parameters)
        self._read_command_line()

    def _read_command_line(self):
        parser = argparse.ArgumentParser()
        # Make argparse list of options
        for name in self.p:
            # Default type: str
            parser.add_argument('--'+name, default=self.p[name])

        args = parser.parse_args()
        for name in self.p:
            self.p[name] = str2obj(getattr(args, name))

```

We could specify the type of a parameter as `type(self.p[name])` or `self.p[name].__class__`, but if a float parameter has been given an integer default value, the type will be `int` and `argparse` will not accept a decimal number as input. Our more general strategy is to drop specifying the type, which implies that all parameters in the `args` object become strings. We then use the `str2obj` function to convert to the right type, a technique that is used throughout the `ReadInput` module.

Reading from a GUI. We can with a little extra effort also make a graphical user interface (GUI) for reading the input data. An example of a user interface is displayed in Figure 9.13. Since the technicalities of the implementation is beyond the scope of this book, we do not show the subclass `GUI` that creates the GUI and loads the user input into the `self.p` dictionary.

a	0
formula	x+1
b	10
filename	tmp.dat
n	2

Run program

Fig. 9.13 Screen dump of a graphical user interface to read input data into a program (class `GUI` in the `ReadInput` hierarchy).

More Flexibility in the Superclass. Some extra flexibility can easily be added to the `get` method in the superclass. Say we want to extract a variable number of parameters:

```

a, b, n = inp.get('a', 'b', 'n') # 3 variables
n = inp.get('n')                 # 1 variable

```

The key to this extension is to use a variable number of arguments as explained in Appendix H.5.1:

```
class ReadInput:
    ...
    def get(self, *parameter_names):
        if len(parameter_names) == 1:
            return self.p[parameter_names[0]]
        else:
            return [self.p[name] for name in parameter_names]
```

Demonstrating the Tool. Let us show how we can use the classes in the `ReadInput` hierarchy. We apply the motivating example described earlier. The name of the program is `demo_ReadInput.py`. As first command-line argument it takes the name of the input source, given as the name of a subclass in the `ReadInput` hierarchy. The code for loading input data from any of the sources supported by the `ReadInput` hierarchy goes as follows:

```
p = dict(formula='x+1', a=0, b=1, n=2, filename='tmp.dat')
from ReadInput import *
input_reader = eval(sys.argv[1]) # PromptUser, ReadInputFile, ...
del sys.argv[1] # otherwise argparse don't like our extra option
inp = input_reader(p)
a, b, filename, formula, n = inp.get_all()
print inp
```

Note how convenient `eval` is to automatically create the right subclass for reading input data.

Our first try on running this program applies the `PromptUser` class:

Terminal

```
demo_ReadInput.py PromptUser
Give a: 0
Give formula: sin(x) + cos(x)
Give b: 10
Give filename: function_data
Give n: 101
{'a': 0,
 'b': 10,
 'filename': 'function_data',
 'formula': 'sin(x) + cos(x)',
 'n': 101}
```

The next example reads data from a file `tmp.inp` with the same contents as shown under the *Reading from File* paragraph above⁷.

Terminal

```
demo_ReadInput.py ReadFileInput < tmp.inp
{'a': 0, 'b': 1, 'filename': 'tmp.dat',
 'formula': 'sin(x) + cos(x)', 'n': 2}
```

⁷ This command with redirection from file must be run from a standard terminal window, not in an interactive IPython session.

We can also drop the redirection of standard input to a file, and instead run an interactive session in IPython or the terminal window:

```

Terminal
demo_ReadInput.py ReadFileInput
n = 101
filename = myfunction_data_file.dat
^D
{'a': 0,
 'b': 1,
 'filename': 'myfunction_data_file.dat',
 'formula': 'x+1',
 'n': 101}
```

Note that `Ctrl-D` is needed to end the interactive session with the user and continue program execution.

Command-line arguments can also be specified:

```

Terminal
demo_ReadInput.py ReadCommandLine \
  --a -1 --b 1 --formula "sin(x) + cos(x)"
{'a': -1, 'b': 1, 'filename': 'tmp.dat',
 'formula': 'sin(x) + cos(x)', 'n': 2}
```

Finally, we can run the program with a GUI,

```

Terminal
demo_ReadInput.py GUI
{'a': -1, 'b': 10, 'filename': 'tmp.dat',
 'formula': 'x+1', 'n': 2}
```

The GUI is shown in Figure 9.13.

Fortunately, it is now quite obvious how to apply the `ReadInput` hierarchy of classes in your own programs to simplify input. Especially in applications with a large number of parameters one can initially define these in a dictionary and then automatically create quite comprehensive user interfaces where the user can specify only some subset of the parameters (if the default values for the rest of the parameters are suitable).

9.7 Exercises

Exercise 9.1. *Demonstrate the magic of inheritance.*

Consider class `Line` from Chapter 9.1.1 and a subclass `Parabola0` defined as

```

class Parabola0(Line):
    pass
```

That is, class `Parabola0` does not have any own code, but it inherits from class `Line`. Demonstrate in a program or interactive session, using

methods from Chapter 7.5.5, that an instance of class `Parabola0` contains everything (i.e., all attributes and methods) that an instance of class `Line` contains. Name of program file: `dir_subclass.py`. \diamond

Exercise 9.2. *Inherit from classes in Ch. 9.1.*

The task in this exercise is to make a class `Cubic` for cubic functions

$$c_3x^3 + c_2x^2 + c_1x + c_0$$

with a call operator and a `table` method as in classes `Line` and `Parabola` from Chapter 9.1. Implement class `Cubic` by inheriting from class `Parabola`, and call up functionality in class `Parabola` in the same way as class `Parabola` calls up functionality in class `Line`.

Make a similar class `Poly4` for 4-th degree polynomials

$$c_4x^4 + c_3x^3 + c_2x^2 + c_1x + c_0$$

by inheriting from class `Cubic`. Insert `print` statements in all the `__call__` to help following the program flow. Evaluate cubic and a 4-th degree polynomial at a point, and observe the printouts from all the superclasses. Name of program file: `Cubic_Poly4.py`. \diamond

Exercise 9.3. *Inherit more from classes in Ch. 9.1.*

Implement a class for the function $f(x) = A \sin(wx) + ax^2 + bx + c$. The class should have a call operator for evaluating the function for some argument x , and a constructor that takes the function parameters A , w , a , b , and c as arguments. Also a `table` method as in classes `Line` and `Parabola` should be present. Implement the class by deriving it from class `Parabola` and call up functionality already implemented in class `Parabola` whenever possible. Name of program file: `sin_plus_quadratic.py`. \diamond

Exercise 9.4. *Reverse the class hierarchy from Ch. 9.1.*

Let class `Polynomial` from Chapter 7.3.7 be a superclass and implement class `Parabola` as a subclass. The constructor in class `Parabola` should take the three coefficients in the parabola as separate arguments. Try to reuse as much code as possible from the superclass in the subclass. Implement class `Line` as a subclass specialization of class `Parabola`.

Which class design do you prefer – class `Line` as a subclass of `Parabola` and `Polynomial`, or `Line` as a superclass with extensions in subclasses? Name of program file: `Polynomial_hier.py`. \diamond

Exercise 9.5. *Make circle a subclass of an ellipse.*

Chapter 7.2.3 presents class `Circle`. Make a similar class `Ellipse` for representing an ellipse. Then create a new class `Circle` that is a subclass of `Ellipse`. Name of program file: `Ellipse_Circle.py`. \diamond

Exercise 9.6. *Make super- and subclass for a point.*

A point (x, y) in the plane can be represented by a class:

```
class Point:
    def __init__(self, x, y):
        self.x, self.y = x, y

    def __str__(self):
        return '%g, %g' % (self.x, self.y)
```

We can extend the `Point` class to also contain the representation of the point in polar coordinates. To this end, create a subclass `PolarPoint` whose constructor takes the polar representation of a point, (r, θ) , as arguments. Store r and θ as attributes and call the superclass constructor with the corresponding x and y values (recall the relations $x = r \cos \theta$ and $y = r \sin \theta$ between Cartesian and polar coordinates). Add a `__str__` method in class `PolarPoint` which prints out r , θ , x , and y . Verify the implementation by initializing three points and printing these points. Name of program file: `PolarPoint.py`. \diamond

Exercise 9.7. *Modify a function class by subclassing.*

Consider the `VelocityProfile` class from page 350 for computing the function $v(r; \beta, \mu_0, n, R)$ in formula (5.23) on page 252. Suppose we want to have v explicitly as a function of r and n (this is necessary if we want to illustrate how the velocity profile, the $v(r)$ curve, varies as n varies). We would then like to have a class `VelocityProfile2` that is initialized with β , μ_0 , and R , and that takes r and n as arguments in the `__call__` method. Implement such a class by inheriting from class `VelocityProfile` and by calling the `__init__` and `value` methods in the superclass. It should be possible to try the class out with the following statements:

```
v = VelocityProfile2(beta=0.06, mu0=0.02, R=2)
# Evaluate v for various n values at r=0
for n in 0.1, 0.2, 1:
    print v(0, n)
```

Name of program file: `VelocityProfile2.py`. \diamond

Exercise 9.8. *Explore the accuracy of difference formulas.*

The purpose of this exercise is to investigate the accuracy of the `Backward1`, `Forward1`, `Forward3`, `Central2`, `Central4`, `Central6` methods for the function⁸

$$v(x) = \frac{1 - e^{x/\mu}}{1 - e^{1/\mu}}.$$

To solve the exercise, modify the `src/oo/Diff2_examples.py` program which produces tables of errors of difference approximations as discussed at the end of Chapter 9.2.3. Test the approximation

⁸ This function is discussed more in detail in Exercise 5.40.

methods for $x = 0, 0.9$ and $\mu = 1, 0.01$. Plot the $v(x)$ function for the two μ values using 1001 points. Name of program file: `boundary_layer_derivative.py`. \diamond

Exercise 9.9. *Implement a subclass.*

Make a subclass `Sine1` of class `FuncWithDerivatives` from Chapter 9.1.7 for the $\sin x$ function. Implement the function only, and rely on the inherited `df` and `ddf` methods for computing the derivatives. Make another subclass `Sine2` for $\sin x$ where you also implement the `df` and `ddf` methods using analytical expressions for the derivatives. Compare `Sine1` and `Sine2` for computing the first- and second-order derivatives of $\sin x$ at two x points. Name of program file: `Sine12.py`. \diamond

Exercise 9.10. *Make classes for numerical differentiation.*

Carry out Exercise 7.13. Find the common code in the classes `Derivative`, `Backward`, and `Central`. Move this code to a superclass, and let the three mentioned classes be subclasses of this superclass. Compare the resulting code with the hierarchy shown in Chapter 9.2.1. Name of program file: `numdiff_classes.py`. \diamond

Exercise 9.11. *Implement a new subclass for differentiation.*

A one-sided, three-point, second-order accurate formula for differentiating a function $f(x)$ has the form

$$f'(x) \approx \frac{f(x-2h) - 4f(x-h) + 3f(x)}{2h}. \quad (9.17)$$

Implement this formula in a subclass `Backward2` of class `Diff` from Chapter 9.2. Compare `Backward2` with `Backward1` for $g(t) = e^{-t}$ for $t = 0$ and $h = 2^{-k}$ for $k = 0, 1, \dots, 14$ (write out the errors in $g'(t)$). Name of program file: `Backward2.py`. \diamond

Exercise 9.12. *Understand if a class can be used recursively.*

Suppose you want to compute $f''(x)$ of some mathematical function $f(x)$, and that you apply some class from Chapter 9.2 twice, e.g.,

```
ddf = Central2(Central2(f))
```

Will this work? Hint: Follow the program flow, and find out what the resulting formula will be. Then see if this formula coincides with a formula you know for approximating $f''(x)$. \diamond

Exercise 9.13. *Represent people by a class hierarchy.*

Classes are often used to model objects in the real world. We may represent the data about a person in a program by a class `Person`, containing the person's name, address, phone number, date of birth, and nationality. A method `__str__` may print the person's data. Implement such a class `Person`.

A worker is a person with a job. In a program, a worker is naturally represented as class `Worker` derived from class `Person`, because a worker *is* a person, i.e., we have an is-a relationship. Class `Worker` extends class `Person` with additional data, say name of company, company address, and job phone number. The print functionality must be modified accordingly. Implement this `Worker` class.

A scientist is a special kind of a worker. Class `Scientist` may therefore be derived from class `Worker`. Add data about the scientific discipline (physics, chemistry, mathematics, computer science, ...). One may also add the type of scientist: theoretical, experimental, or computational. The value of such a type attribute should not be restricted to just one category, since a scientist may be classified as, e.g., both experimental and computational (i.e., you can represent the value as a list or tuple). Implement class `Scientist`.

Researcher, postdoc, and professor are special cases of a scientist. One can either create classes for these job positions, or one may add an attribute (`position`) for this information in class `Scientist`. We adopt the former strategy. When, e.g., a researcher is represented by a class `Researcher`, no extra data or methods are needed. In Python we can create such an “empty” class by writing `pass` (the empty statement) as the class body:

```
class Researcher(Scientist):
    pass
```

Finally, make a demo program where you create and print instances of classes `Person`, `Worker`, `Scientist`, `Researcher`, `Postdoc`, and `Professor`. Print out the attribute contents of each instance (use the `dir` function).

Remark. An alternative design is to introduce a class `Teacher` as a special case of `Worker` and let `Professor` be both a `Teacher` and `Scientist`, which is natural. This implies that class `Professor` has two superclasses, `Teacher` and `Scientist`, or equivalently, class `Professor` inherits from two superclasses. This is known as *multiple inheritance* and technically achieved as follows in Python:

```
class Professor(Teacher, Scientist):
    pass
```

It is a continuous debate in computer science whether multiple inheritance is a good idea or not. One obvious problem⁹ in the present example is that class `Professor` inherits two names, one via `Teacher` and one via `Scientist` (both these classes inherit from `Person`). Neither of the two widely used languages Java and C# allow multiple inheritance. Nor in this book will we pursue the idea of multiple inheritance further. Name of program file: `Person.py`. ◊

⁹ It is usually not a technical problem, but more a conceptual problem when the world is modeled by objects in a program.

Exercise 9.14. *Add a new class in a class hierarchy.*

Add the Monte Carlo integration method from Chapter 8.5.1 as a subclass in the `Integrator` hierarchy explained in Chapter 9.3. Import the superclass `Integrator` from the `integrate` module in the file with the new integration class. Test the Monte Carlo integration class in a case with known analytical solution. Name of program file: `MCint_class.py`. \diamond

Exercise 9.15. *Change the user interface of a class hierarchy.*

All the classes in the `Integrator` hierarchy from Chapter 9.3 take the integration limits a and b plus the number of integration points n as input to the constructor. The `integrate` method takes the function to integrate, $f(x)$, as parameter. Another possibility is to feed $f(x)$ to the constructor and let `integrate` take a , b , and n as parameters. Make this change to the `integrate.py` file with the `Integrator` hierarchy. Name of program file: `integrate2.py`. \diamond

Exercise 9.16. *Compute convergence rates of numerical integration methods.*

Most numerical methods have a discretization parameter, call it n , such that if n increases (or decreases), the method performs better. Often, the relation between the error in the numerical approximation (compared with the exact analytical result) can be written as

$$E = Cn^r,$$

where E is the error, and C and r are constants.

Suppose you have performed an experiment with a numerical method using discretization parameters n_0, n_1, \dots, n_N . You have computed the corresponding errors E_0, E_1, \dots, E_N in a test problem with an analytical solution. One way to estimate r goes as follows. For two successive experiments we have

$$E_{i-1} = Cn_{i-1}^r$$

and

$$E_i = Cn_i^r.$$

Divide the first equation by the second to eliminate C , and then take the logarithm to solve for r :

$$r = \frac{\ln(E_{i-1}/E_i)}{\ln(n_{i-1}/n_i)}.$$

We can compute r for all pairs of two successive experiments. Usually, the “last r ”, corresponding to $i = N$ in the formula above, is the “best” r value¹⁰. Knowing r , we can compute C as $E_N n_N^{-r}$.

¹⁰ This guideline is good if the method converges and round-off errors do not influence the values of E_i . For very large/small n , the computation of r may be unreliable.

Having stored the n_i and E_i values in two lists `n` and `E`, the following code snippet computes r and C :

```
from scitools.convergenrate import convergence_rate
C, r = convergence_rate(n, E)
```

Construct a test problem for integration where you know the analytical result of the integral. Run different numerical methods (the Midpoint method, the Trapezoidal method, Simpson's method, Monte Carlo integration) with the number of evaluation points $n = 2^k + 1$ for $k = 2, \dots, 11$, compute corresponding errors, and use the code snippet above to compute the r value for the different methods in questions. The higher the absolute error of r is, the faster the method converges to the exact result as n increases, and the better the method is. Which is the best and which is the worst method?

Let the program file import methods from the `integrate` module and the module with the Monte Carlo integration method from Exercise 9.14. Name of program file: `integrators_convergence.py`. \diamond

Exercise 9.17. *Add common functionality in a class hierarchy.*

Suppose you want to use classes in the `Integrator` hierarchy from Chapter 9.3 to calculate integrals of the form

$$F(x) = \int_a^x f(t)dt.$$

Such functions $F(x)$ can be efficiently computed by the method from Exercise 7.28. Implement this computation of $F(x)$ in an additional method in the superclass `Integrator`. Test that the implementation is correct for $f(x) = 2x - 3$ for all the implemented integration methods (the Midpoint, Trapezoidal and Gauss-Legendre methods, as well as Simpson's rule, integrate a linear function exactly). Name of program file: `integrate_efficient.py`. \diamond

Exercise 9.18. *Make a class hierarchy for root finding.*

Given a general nonlinear equation $f(x) = 0$, we want to implement classes for solving such an equation, and organize the classes in a class hierarchy. Make classes for three methods: Newton's method (Appendix A.1.10), the Bisection method (Chapter 4.6.2), and the Secant method (Exercise A.14).

It is not obvious how such a hierarchy should be organized. One idea is to let the superclass store the $f(x)$ function and its derivative $f'(x)$ (if provided – if not, use a finite difference approximation for $f'(x)$). A method

```
def solve(start_values=[0], max_iter=100, tolerance=1E-6):
    ...
```

in the superclass can implement a general iteration loop. The `start_values` argument is a list of starting values for the algorithm in

question: one point for Newton, two for Secant, and an interval $[a, b]$ containing a root for Bisection. Let `solve` define a list `self.x` holding all the computed approximations. The initial value of `self.x` is simply `start_values`. For the Bisection method, one can use the convention `a, b, c = self.x[-3:]`, where $[a, b]$ represents the most recently computed interval and c is its midpoint. The `solve` method can return an approximate root x , the corresponding $f(x)$ value, a boolean indicator that is `True` if $|f(x)|$ is less than the `tolerance` parameter, and a list of all the approximations and their f values (i.e., a list of $(x, f(x))$ tuples).

Do Exercise A.15 using the new class hierarchy. Name of program file: `Rootfinders.py`. \diamond

Exercise 9.19. *Make a calculus calculator class.*

Given a function $f(x)$ defined on a domain $[a, b]$, the purpose of many mathematical exercises is to sketch the function curve $y = f(x)$, compute the derivative $f'(x)$, find local and global extreme points, and compute the integral $\int_a^b f(x)dx$. Make a class `CalculusCalculator` which can perform all these actions for any function $f(x)$ using numerical differentiation and integration, and the method explained in Exercise 7.42 or 7.43 for finding extrema.

Here is an interactive session with the class where we analyze $f(x) = x^2 e^{-0.2x} \sin(2\pi x)$ on $[0, 6]$ with a grid (set of x coordinates) of 700 points:

```
>>> from CalculusCalculator import *
>>> def f(x):
...     return x**2*exp(-0.2*x)*sin(2*pi*x)
...
>>> c = CalculusCalculator(f, 0, 6, resolution=700)
>>> c.plot()           # plot f
>>> c.plot_derivative() # plot f'
>>> c.extreme_points()

All minima: 0.8052, 1.7736, 2.7636, 3.7584, 4.7556, 5.754, 0
All maxima: 0.3624, 1.284, 2.2668, 3.2604, 4.2564, 5.2548, 6
Global minimum: 5.754
Global maximum: 5.2548

>>> c.integral
-1.7353776102348935
>>> c.df(2.51)      # c.df(x) is the derivative of f
-24.056988888465636
>>> c.set_differentiation_method(Central4)
>>> c.df(2.51)
-24.056988832723189
>>> c.set_integration_method(Simpson) # more accurate integration
>>> c.integral
-1.7353857856973565
```

Design the class such that the above session can be carried out.

Hint: Use classes from the `Diff` and `Integrator` hierarchies (Chapters 9.2 and 9.3) for numerical differentiation and integration (with, e.g., `Central12` and `Trapezoidal` as default methods for differentiation

and integration). The method `set_differentiation_method` takes a subclass name in the `Diff` hierarchy as argument, and makes an attribute `df` that holds a subclass instance for computing derivatives. With `set_integration_method` we can similarly set the integration method as a subclass name in the `Integrator` hierarchy, and then compute the integral $\int_a^b f(x)dx$ and store the value in the attribute `integral`. The `extreme_points` method performs a `print` on a `MinMax` instance, which is stored as an attribute in the calculator class. Name of program file: `CalculusCalculator.py`. ◇

Exercise 9.20. *Extend Exer. 9.19.*

Extend class `CalculusCalculator` from Exercise 9.19 to offer computations of inverse functions. A numerical way of computing inverse functions is explained in Appendix A.1.11. Exercise 7.26 suggests an improved implementation using classes. Use the `InverseFunction` implementation from Exercise 7.26 in class `CalculusCalculator`. Name of program file: `CalculusCalculator2.py`. ◇

Exercise 9.21. *Make line drawing of a person; program.*

A very simple sketch of a human being can be made of a circle for the head, two lines for the arms, one vertical line, a triangle, or a rectangle for the torso, and two lines for the legs. Make such a drawing in a program, utilizing appropriate classes in the `Shape` hierarchy. Name of program file: `draw_person.py`. ◇

Exercise 9.22. *Make line drawing of a person; class.*

Use the code from Exercise 9.21 to make a subclass of `Shape` that draws a person. Supply the following arguments to the constructor: the center point of the head and the radius R of the head. Let the arms and the torso be of length $4R$, and the legs of length $6R$. The angle between the legs can be fixed (say 30 degrees), while the angle of the arms relative to the torso can be an argument to the constructor with a suitable default value. Name of program file: `Person.py`. ◇

Exercise 9.23. *Animate a person with waving hands.*

Make a subclass of the class from Exercise 9.22 where the constructor can take an argument describing the angle between the arms and the torso. Use this new class to animate a person who waves her/his hands. Name of program file: `waving_person.py`. ◇

From mathematics you probably know the concept of a *sequence*, which is nothing but a collection of numbers with a specific order. A general sequence is written as

$$x_0, x_1, x_2, \dots, x_n, \dots$$

One example is the sequence of all odd numbers:

$$1, 3, 5, 7, \dots, 2n + 1, \dots$$

For this sequence we have an explicit formula for the n -th term: $2n + 1$, and n takes on the values $0, 1, 2, \dots$. We can write this sequence more compactly as $(x_n)_{n=0}^{\infty}$ with $x_n = 2n + 1$. Other examples of infinite sequences from mathematics are

$$1, 4, 9, 16, 25, \dots \quad (x_n)_{n=0}^{\infty}, \quad x_n = (n + 1)^2, \quad (\text{A.1})$$

$$1, \frac{1}{2}, \frac{1}{3}, \frac{1}{4}, \dots \quad (x_n)_{n=0}^{\infty}, \quad x_n = \frac{1}{n + 1}. \quad (\text{A.2})$$

The former sequences are infinite, because they are generated from all integers ≥ 0 and there are infinitely many such integers. Nevertheless, most sequences from real life applications are finite. If you put an amount x_0 of money in a bank, you will get an interest rate and therefore have an amount x_1 after one year, x_2 after two years, and x_N after N years. This process results in a finite sequence of amounts

$$x_0, x_1, x_2, \dots, x_N, \quad (x_n)_{n=0}^N.$$

Usually we are interested in quite small N values (typically $N \leq 20 - 30$). Anyway, the life of the bank is finite, so the sequence definitely has an end.

For some sequences it is not so easy to set up a general formula for the n -th term. Instead, it is easier to express a relation between two or more consecutive elements. One example where we can do both things is the sequence of odd numbers. This sequence can alternatively be generated by the formula

$$x_{n+1} = x_n + 2. \tag{A.3}$$

To start the sequence, we need an *initial condition* where the value of the first element is specified:

$$x_0 = 1.$$

Relations like (A.3) between consecutive elements in a sequence is called recurrence relations or *difference equations*. Solving a difference equation can be quite challenging in mathematics, but it is almost trivial to solve it on a computer. That is why difference equations are so well suited for computer programming, and the present appendix is devoted to this topic. Only programming concepts from Chapters 1–5 are used in the material herein.

The program examples regarding difference equations are found in the folder `src/diffeq`.

A.1 Mathematical Models Based on Difference Equations

The objective of science is to understand complex phenomena. The phenomenon under consideration may be a part of nature, a group of social individuals, the traffic situation in Los Angeles, and so forth. The reason for addressing something in a scientific manner is that it appears to be complex and hard to comprehend. A common scientific approach to gain understanding is to create a model of the phenomenon, and discuss the properties of the model instead of the phenomenon. The basic idea is that the model is easier to understand, but still complex enough to preserve the basic features of the problem at hand¹. Modeling is, indeed, a general idea with applications far beyond science. Suppose, for instance, that you want to invite a friend to your home for the first time. To assist your friend, you may send a map of your neighborhood. Such a map is a model: It exposes the most important landmarks and leave out billions of details that your friend can do very well without. This is the essence of modeling: A good model should be as simple as possible, but still rich enough to include the important structures you are looking for².

¹ “Essentially, all models are wrong, but some are useful.” –George E. P. Box, statistician, 1919–.

² “Everything should be made as simple as possible, but not simpler.” –Albert Einstein, physicist, 1879–1955.

Certainly, the tools we apply to model a certain phenomenon differ a lot in various scientific disciplines. In the natural sciences, mathematics has gained a unique position as the key tool for formulating models. To establish a model, you need to understand the problem at hand and describe it with mathematics. Usually, this process results in a set of equations, i.e., the model consists of equations that must be solved in order to see how realistically the model describes a phenomenon. Difference equations represent one of the simplest yet most effective type of equations arising in mathematical models. The mathematics is simple and the programming is simple, thereby allowing us to focus more on the modeling part. Below we will derive and solve difference equations for diverse applications.

A.1.1 Interest Rates

Our first difference equation model concerns how much money an initial amount x_0 will grow to after n years in a bank with annual interest rate p . You learned in school the formula

$$x_n = x_0 \left(1 + \frac{p}{100}\right)^n. \quad (\text{A.4})$$

Unfortunately, this formula arises after some limiting assumptions, like that of a constant interest rate over all the n years. Moreover, the formula only gives us the amount after each year, not after some months or days. It is much easier to compute with interest rates if we set up a more fundamental model in terms of a difference equation and then solve this equation on a computer.

The fundamental model for interest rates is that an amount x_{n-1} at some point of time t_{n-1} increases its value with p percent to an amount x_n at a new point of time t_n :

$$x_n = x_{n-1} + \frac{p}{100}x_{n-1}. \quad (\text{A.5})$$

If n counts years, p is the annual interest rate, and if p is constant, we can with some arithmetics derive the following solution to (A.5):

$$x_n = \left(1 + \frac{p}{100}\right)x_{n-1} = \left(1 + \frac{p}{100}\right)^2 x_{n-2} = \cdots = \left(1 + \frac{p}{100}\right)^n x_0.$$

Instead of first deriving a formula for x_n and then program this formula, we may attack the fundamental model (A.5) in a program (`growth_years.py`) and compute x_1 , x_2 , and so on in a loop:

```
from scitools.std import *
x0 = 100                # initial amount
p = 5                  # interest rate
N = 4                  # number of years
```

```

index_set = range(N+1)
x = zeros(len(index_set))

# Compute solution
x[0] = x0
for n in index_set[1:]:
    x[n] = x[n-1] + (p/100.0)*x[n-1]
print x
plot(index_set, x, 'ro', xlabel='years', ylabel='amount')

```

The output of `x` is

```
[ 100.      105.      110.25     115.7625    121.550625]
```

Programmers of mathematical software who are trained in making programs more efficient, will notice that it is not necessary to store all the x_n values in an array or use a list with all the indices $0, 1, \dots, N$. Just one integer for the index and two floats for x_n and x_{n-1} are strictly necessary. This can save quite some memory for large values of N . Exercise A.5 asks you to develop such a memory-efficient program.

Suppose now that we are interested in computing the growth of money after N days instead. The interest rate per day is taken as $r = p/D$ if p is the annual interest rate and D is the number of days in a year. The fundamental model is the same, but now n counts days and p is replaced by r :

$$x_n = x_{n-1} + \frac{r}{100}x_{n-1}. \quad (\text{A.6})$$

A common method in international business is to choose $D = 360$, yet let n count the exact number of days between two dates (see footnote on page 161). Python has a module `datetime` for convenient calculations with dates and times. To find the number of days between two dates, we perform the following operations:

```

>>> import datetime
>>> date1 = datetime.date(2007, 8, 3) # Aug 3, 2007
>>> date2 = datetime.date(2008, 8, 4) # Aug 4, 2008
>>> diff = date2 - date1
>>> print diff.days
367

```

We can modify the previous program to compute with days instead of years:

```

from scitools.std import *
x0 = 100 # initial amount
p = 5 # annual interest rate
r = p/360.0 # daily interest rate
import datetime
date1 = datetime.date(2007, 8, 3)
date2 = datetime.date(2011, 8, 3)
diff = date2 - date1
N = diff.days
index_set = range(N+1)
x = zeros(len(index_set))

# Compute solution
x[0] = x0

```

```

for n in index_set[1:]:
    x[n] = x[n-1] + (r/100.0)*x[n-1]
print x
plot(index_set, x, 'ro', xlabel='days', ylabel='amount')

```

Running this program, called `growth_days.py`, prints out 122.5 as the final amount.

It is quite easy to adjust the formula (A.4) to the case where the interest is added every day instead of every year. However, the strength of the model (A.6) and the associated program `growth_days.py` becomes apparent when r varies in time – and this is what happens in real life. In the model we can just write $r(n)$ to explicitly indicate the dependence upon time. The corresponding time-dependent annual interest rate is what is normally specified, and $p(n)$ is usually a piecewise constant function (the interest rate is changed at some specific dates and remains constant between these days). The construction of a corresponding array `p` in a program, given the dates when p changes, can be a bit tricky since we need to compute the number of days between the dates of changes and index `p` properly. We do not dive into these details now, but readers who want to compute `p` and who is ready for some extra brain training and index puzzling can attack Exercise A.11. For now we assume that an array `p` holds the time-dependent annual interest rates for each day in the total time period of interest. The `growth_days.py` program then needs a slight modification, typically,

```

p = zeros(len(index_set))
# set up p (might be challenging!)
r = p/360.0 # daily interest rate
...
for n in index_set[1:]:
    x[n] = x[n-1] + (r[n-1]/100.0)*x[n-1]

```

For the very simple (and not-so-relevant) case where p grows linearly (i.e., daily changes) from 4 to 6 percent over the period of interest, we have made a complete program in the file `growth_days_timedep.py`. You can compare a simulation with linearly varying p between 4 and 6 and a simulation using the average p value 5 throughout the whole time interval.

A difference equation with $r(n)$ is quite difficult to solve mathematically, but the n -dependence in r is easy to deal with in the computerized solution approach.

A.1.2 The Factorial as a Difference Equation

The difference equation

$$x_n = nx_{n-1}, \quad x_0 = 1 \tag{A.7}$$

can quickly be solved recursively:

$$\begin{aligned}
 x_n &= nx_{n-1} \\
 &= n(n-1)x_{n-2} \\
 &= n(n-1)(n-2)x_{n-3} \\
 &= n(n-1)(n-2)\cdots 1.
 \end{aligned}$$

The result x_n is nothing but the factorial of n , denoted as $n!$ (cf. Exercise 3.19). Equation (A.7) then gives a standard recipe to compute $n!$.

A.1.3 Fibonacci Numbers

Every textbook with some material on sequences usually presents a difference equation for generating the famous Fibonacci numbers³:

$$x_n = x_{n-1} + x_{n-2}, \quad x_0 = 1, \quad x_1 = 1, \quad n = 2, 3, \dots \quad (\text{A.8})$$

This equation has a relation between three elements in the sequence, not only two as in the other examples we have seen. We say that this is a difference equation of second order, while the previous examples involving two n levels are said to be difference equations of first order. The precise characterization of (A.8) is a homogeneous difference equation of second order. Such classification is not important when computing the solution in a program, but for mathematical solution methods by pen and paper, the classification helps to determine which mathematical technique to use to solve the problem.

A straightforward program for generating Fibonacci numbers takes the form (`fibonacci1.py`):

```
import sys
import numpy as np
N = int(sys.argv[1])
x = np.zeros(N+1, int)
x[0] = 1
x[1] = 1
for n in range(2, N+1):
    x[n] = x[n-1] + x[n-2]
print n, x[n]
```

Since x_n is an infinite sequence we could try to run the program for very large N . This causes two problems: The storage requirements of the `x` array may become too large for the computer, but long before this happens, x_n grows in size far beyond the largest integer that can be represented by `int` elements in arrays (the problem appears already for $N = 50$). A possibility is to use array elements of type `int64`, which allows computation of twice as many numbers as with standard `int` elements (see the program `fibonacci1_int64.py`). A better solution is to use `float` elements in the `x` array, despite the fact that the numbers

³ Fibonacci arrived at this equation when modelling rabbit populations.

x_n are integers. With `float96` elements we can compute up to $N = 23600$ (see the program `fibonacci1_float.py`).

The best solution goes as follows. We observe, as mentioned after the `growth_years.py` program and also explained in Exercise A.5, that we need only three variables to generate the sequence. We can therefore work with just three standard `int` variables in Python:

```
import sys
N = int(sys.argv[1])
xnm1 = 1
xnm2 = 1
n = 2
while n <= N:
    xn = xnm1 + xnm2
    print 'x_%d = %d' % (n, xn)
    xnm2 = xnm1
    xnm1 = xn
    n += 1
```

Here `xnm1` denotes x_{n-1} and `xnm2` denotes x_{n-2} . To prepare for the next pass in the loop, we must shuffle the `xnm1` down to `xnm2` and store the new x_n value in `xnm1`. The nice thing with `int` objects in Python (contrary to `int` elements in NumPy arrays) is that they can hold integers of arbitrary size⁴. We may try a run with `N` set to 250:

```
x_2 = 2
x_3 = 3
x_4 = 5
x_5 = 8
x_6 = 13
x_7 = 21
x_8 = 34
x_9 = 55
x_10 = 89
x_11 = 144
x_12 = 233
x_13 = 377
x_14 = 610
x_15 = 987
x_16 = 1597
...
x_249 = 7896325826131730509282738943634332893686268675876375
x_250 = 12776523572924732586037033894655031898659556447352249
```

In mathematics courses you learn how to derive a formula for the n -th term in a Fibonacci sequence. This derivation is much more complicated than writing a simple program to generate the sequence, but there is a lot of interesting mathematics both in the derivation and the resulting formula!

A.1.4 Growth of a Population

Let x_{n-1} be the number of individuals in a population at time t_{n-1} . The population can consist of humans, animals, cells, or whatever objects where the number of births and deaths is proportional to the number of individuals. Between time levels t_{n-1} and t_n , bx_{n-1} individuals are

⁴ Note that `int` variables in other computer languages normally has a size limitation like `int` elements in NumPy arrays.

born, and dx_{n-1} individuals die, where b and d are constants. The net growth of the population is then $(b-d)x_n$. Introducing $r = (b-d)100$ for the net growth factor measured in percent, the new number of individuals become

$$x_n = x_{n-1} + \frac{r}{100}x_{n-1}. \quad (\text{A.9})$$

This is the same difference equation as (A.5). It models growth of populations quite well as long as there are optimal growing conditions for each individual. If not, one can adjust the model as explained in Appendix A.1.5.

To solve (A.9) we need to start out with a known size x_0 of the population. The b and d parameters depend on the time difference $t_n - t_{n-1}$, i.e., the values of b and d are smaller if n counts years than if n counts generations.

A.1.5 Logistic Growth

The model (A.9) for the growth of a population leads to exponential increase in the number of individuals as implied by the solution (A.4). The size of the population increases faster and faster as time n increases, and $x_n \rightarrow \infty$ when $n \rightarrow \infty$. In real life, however, there is an upper limit M of the number of individuals that can exist in the environment at the same time. Lack of space and food, competition between individuals, predators, and spreading of contagious diseases are examples on factors that limit the growth. The number M is usually called the *carrying capacity* of the environment, the maximum population which is sustainable over time. With limited growth, the growth factor r must depend on time:

$$x_n = x_{n-1} + \frac{r(n-1)}{100}x_{n-1}. \quad (\text{A.10})$$

In the beginning of the growth process, there is enough resources and the growth is exponential, but as x_n approaches M , the growth stops and r must tend to zero. A simple function $r(n)$ with these properties is

$$r(n) = \varrho \left(1 - \frac{x_n}{M} \right). \quad (\text{A.11})$$

For small n , $x_n \ll M$ and $r(n) \approx \varrho$, which is the growth rate with unlimited resources. As $n \rightarrow M$, $r(n) \rightarrow 0$ as we want. The model (A.11) is used for *logistic growth*. The corresponding *logistic difference equation* becomes

$$x_n = x_{n-1} + \frac{\varrho}{100}x_{n-1} \left(1 - \frac{x_{n-1}}{M} \right). \quad (\text{A.12})$$

Below is a program (`growth_logistic.py`) for simulating $N = 200$ time intervals in a case where we start with $x_0 = 100$ individuals, a carrying capacity of $M = 500$, and initial growth of $\rho = 4$ percent in each time interval:

```
from scitools.std import *
x0 = 100          # initial amount of individuals
M = 500          # carrying capacity
rho = 4          # initial growth rate in percent
N = 200          # number of time intervals
index_set = range(N+1)
x = zeros(len(index_set))

# Compute solution
x[0] = x0
for n in index_set[1:]:
    x[n] = x[n-1] + (rho/100.0)*x[n-1]*(1 - x[n-1]/float(M))
print x
plot(index_set, x, 'r', xlabel='time units',
      ylabel='no of individuals', hardcopy='tmp.eps')
```

Figure A.1 shows how the population stabilizes, i.e., that x_n approaches M as N becomes large (of the same magnitude as M).

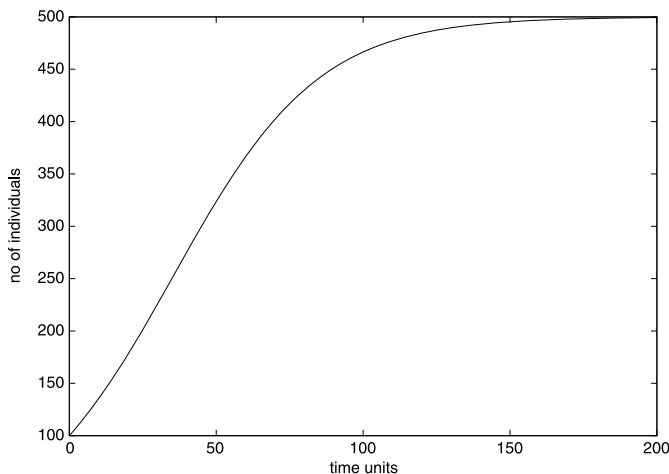

Fig. A.1 Logistic growth of a population ($\rho = 4$, $M = 500$, $x_0 = 100$, $N = 200$).

If the equation stabilizes as $n \rightarrow \infty$, it means that $x_n = x_{n-1}$ in this limit. The equation then reduces to

$$x_n = x_n + \frac{\rho}{100}x_n \left(1 - \frac{x_n}{M}\right).$$

By inserting $x_n = M$ we see that this solution fulfills the equation. The same solution technique (i.e., setting $x_n = x_{n-1}$) can be used to check if x_n in a difference equation approaches a limit or not.

Mathematical models like (A.12) are often easier to work with if we *scale* the variables, as briefly describe in Chapter 5.8.2. Basically, this means that we divide each variable by a characteristic size of that

variable such that the value of the new variable is typically 1. In the present case we can scale x_n by M and introduce a new variable,

$$y_n = \frac{x_n}{M}.$$

Similarly, x_0 is replaced by $y_0 = x_0/M$. Inserting $x_n = My_n$ in (A.12) and dividing by M gives

$$y_n = y_{n-1} + qy_{n-1}(1 - y_{n-1}), \quad (\text{A.13})$$

where $q = \varrho/100$ is introduced to save typing. Equation (A.13) is simpler than (A.12) in that the solution lies approximately between⁵ y_0 and 1, and there are only two dimensionless input parameters to care about: q and y_0 . To solve (A.12) we need knowledge of three parameters: x_0 , ϱ , and M .

A.1.6 Payback of a Loan

A loan L is to be paid back over N months. The payback in a month consists of the fraction L/N plus the interest increase of the loan. Let the annual interest rate for the loan be p percent. The monthly interest rate is then $\frac{p}{12}$. The value of the loan after month n is x_n , and the change from x_{n-1} can be modeled as

$$x_n = x_{n-1} + \frac{p}{12 \cdot 100} x_{n-1} - \left(\frac{p}{12 \cdot 100} x_{n-1} + \frac{L}{N} \right), \quad (\text{A.14})$$

$$= x_{n-1} - \frac{L}{N}, \quad (\text{A.15})$$

for $n = 1, \dots, N$. The initial condition is $x_0 = L$. A major difference between (A.15) and (A.6) is that all terms in the latter are proportional to x_n or x_{n-1} , while (A.15) also contains a constant term (L/N). We say that (A.6) is homogeneous and linear, while (A.15) is inhomogeneous (because of the constant term) and linear. The mathematical solution of inhomogeneous equations are more difficult to find than the solution of homogeneous equations, but in a program there is no big difference: We just add the extra term $-L/N$ in the formula for the difference equation.

The solution of (A.15) is not particularly exciting⁶. What is more interesting, is what we pay each month, y_n . We can keep track of both y_n and x_n in a variant of the previous model:

⁵ Values larger than 1 can occur, see Exercise A.23.

⁶ Use (A.15) repeatedly to derive the solution $x_n = L - nL/N$.

$$y_n = \frac{p}{12 \cdot 100} x_{n-1} + \frac{L}{N}, \quad (\text{A.16})$$

$$x_n = x_{n-1} + \frac{p}{12 \cdot 100} x_{n-1} - y_n. \quad (\text{A.17})$$

Equations (A.16)–(A.17) is a system of difference equations. In a computer code, we simply update y_n first, and then we update x_n , inside a loop over n . Exercise A.6 asks you to do this.

A.1.7 The Integral as a Difference Equation

Suppose a function $f(x)$ is defined as the integral

$$f(x) = \int_a^x g(t) dt. \quad (\text{A.18})$$

Our aim is to evaluate $f(x)$ at a set of points $x_0 = a < x_1 < \cdots < x_N$. The value $f(x_n)$ for any $0 \leq n \leq N$ can be obtained by using the Trapezoidal rule for integration:

$$f(x_n) = \sum_{k=0}^{n-1} \frac{1}{2} (x_{k+1} - x_k) (g(x_k) + g(x_{k+1})), \quad (\text{A.19})$$

which is nothing but the sum of the areas of the trapezoids up to the point x_n (Figure 5.14b on page 255 illustrates the idea.) We realize that $f(x_{n+1})$ is the sum above plus the area of the next trapezoid:

$$f(x_{n+1}) = f(x_n) + \frac{1}{2} (x_{n+1} - x_n) (g(x_n) + g(x_{n+1})). \quad (\text{A.20})$$

This is a much more efficient formula than using (A.19) with n replaced by $n + 1$, since we do not need to recompute the areas of the first n trapezoids.

Formula (A.20) gives the idea of computing all the $f(x_n)$ values through a difference equation. Define f_n as $f(x_n)$ and consider $x_0 = a$, and x_1, \dots, x_N as given. We know that $f_0 = 0$. Then

$$f_n = f_{n-1} + \frac{1}{2} (x_n - x_{n-1}) (g(x_{n-1}) + g(x_n)), \quad (\text{A.21})$$

for $n = 1, 2, \dots, N$. By introducing g_n for $g(x_n)$ as an extra variable in the difference equation, we can avoid recomputing $g(x_n)$ when we compute f_{n+1} :

$$g_n = g(x_n), \quad (\text{A.22})$$

$$f_n = f_{n-1} + \frac{1}{2} (x_n - x_{n-1}) (g_{n-1} + g_n), \quad (\text{A.23})$$

with initial conditions $f_0 = 0$ and $g_0 = g(a)$.

A function can take g , a , x , and N as input and return arrays x and f for x_0, \dots, x_N and the corresponding integral values f_0, \dots, f_N :

```
def integral(g, a, x, N=20):
    index_set = range(N+1)
    x = np.linspace(a, x, N+1)
    g_ = np.zeros_like(x)
    f = np.zeros_like(x)
    g_[0] = g(x[0])
    f[0] = 0

    for n in index_set[1:]:
        g_[n] = g(x[n])
        f[n] = f[n-1] + 0.5*(x[n] - x[n-1])*(g_[n-1] + g_[n])
    return x, f
```

Note that g is used for the integrand function to call so we introduce $g_$ to be the array holding sequence of $g(x[n])$ values.

Our first task, after having implemented a mathematical calculation, is to verify the result. Here we can make use of the nice fact that the Trapezoidal rule is exact for linear functions $g(t)$:

```
def _verify():
    """
    Check that the trapezoidal method implemented
    via difference equations works perfectly with linear g.
    """
    def g_test(t):
        """Linear integrand."""
        return 2*t + 1

    def f_test(x, a):
        """Exact integral of g_test."""
        return x**2 + x - (a**2 + a)

    a = 2
    x, f = integral(g_test, a, x=10)
    f_exact = f_test(x, a)
    if not np.allclose(f_exact, f):
        print 'ERROR in _verify'
```

A realistic application is to apply the `integral` function to some $g(t)$ where there is no formula for the analytical integral, e.g.,

$$g(t) = \frac{1}{\sqrt{2\pi}} \exp(-t^2).$$

The code may look like

```
from numpy import sqrt, pi, exp
def g(t):
    return 1./sqrt(2*pi)*exp(-t**2)

x, f = integral(g, a=-3, x=3, N=200)
integrand = g(x)
from scitools.std import plot
plot(x, f, 'r-',
     x, integrand, 'y-',
     legend=('f', 'g'),
     legend_loc='upper left')
```

Figure A.2 displays the integrand and the integral. All the code is available in the file `integral.py`.

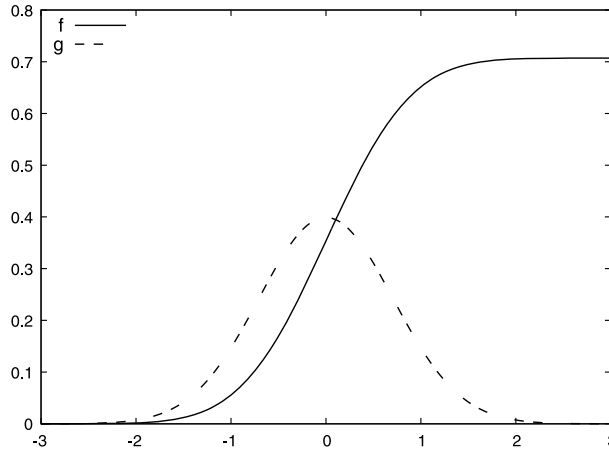

Fig. A.2 Integral of $\frac{1}{\sqrt{2\pi}} \exp(-t^2)$ from -3 to x .

A.1.8 Taylor Series as a Difference Equation

Consider the following system of two difference equations

$$e_n = e_{n-1} + a_{n-1}, \quad (\text{A.24})$$

$$a_n = \frac{x}{n} a_{n-1}, \quad (\text{A.25})$$

with initial conditions $e_0 = 0$ and $a_0 = 1$. We can start to nest the solution:

$$\begin{aligned} e_1 &= 0 + a_0 = 0 + 1 = 1, \\ a_1 &= x, \\ e_2 &= e_1 + a_1 = 1 + x, \\ a_2 &= \frac{x}{2} a_1 = \frac{x^2}{2}, \\ e_3 &= e_2 + a_2 = 1 + x + \frac{x^2}{2}, \\ e_4 &= 1 + x + \frac{x^2}{2} + \frac{x^3}{3 \cdot 2}, \\ e_5 &= 1 + x + \frac{x^2}{2} + \frac{x^3}{3 \cdot 2} + \frac{x^4}{4 \cdot 3 \cdot 2}. \end{aligned}$$

The observant reader who has heard about Taylor series (see Chapter B.4) will recognize this as the Taylor series of e^x :

$$e^x = \sum_{n=0}^{\infty} \frac{x^n}{n!}. \quad (\text{A.26})$$

How do we derive a system like (A.24)–(A.25) for computing the Taylor polynomial approximation to e^x ? The starting point is the sum $\sum_{n=0}^{\infty} \frac{x^n}{n!}$. This sum is coded by adding new terms to an accumulation variable in a loop. The mathematical counterpart to this code is a difference equation

$$e_{n+1} = e_n + \frac{x^n}{n!}, \quad e_0 = 0, \quad n = 0, 1, 2, \dots \quad (\text{A.27})$$

or equivalently (just replace n by $n - 1$):

$$e_n = e_{n-1} + \frac{x^{n-1}}{(n-1)!}, \quad e_0 = 0, \quad n = 1, 2, 3, \dots \quad (\text{A.28})$$

Now comes the important observation: the term $x^n/n!$ contains many of the computations we already performed for the previous term $x^{n-1}/(n-1)!$ because

$$\frac{x^n}{n!} = \frac{x \cdot x \cdots x}{n(n-1)(n-2) \cdots 1}, \quad \frac{x^{n-1}}{(n-1)!} = \frac{x \cdot x \cdots x}{(n-1)(n-2)(n-3) \cdots 1}.$$

Let $a_n = x^n/n!$. We see that we can go from a_{n-1} to a_n by multiplying a_{n-1} by x/n :

$$\frac{x}{n} a_{n-1} = \frac{x}{n} \frac{x^{n-1}}{(n-1)!} = \frac{x^n}{n!} = a_n, \quad (\text{A.29})$$

which is nothing but (A.25). We also realize that $a_0 = 1$ is the initial condition for this difference equation. In other words, (A.24) sums the Taylor polynomial, and (A.25) updates each term in the sum.

The system (A.24)–(A.25) is very easy to implement in a program and constitutes an efficient way to compute (A.26). The function `exp_diffeq` does the work⁷:

```
def exp_diffeq(x, N):
    n = 1
    an_prev = 1.0 # a_0
    en_prev = 0.0 # e_0
    while n <= N:
        en = en_prev + an_prev
        an = x/n*an_prev
        en_prev = en
        an_prev = an
        n += 1
    return en
```

⁷ Observe that we do not store the sequences in arrays, but make use of the fact that only the most recent sequence element is needed to calculate a new element.

This function along with a direct evaluation of the Taylor series for e^x and a comparison with the exact result for various N values can be found in the file `exp_Taylor_series_diffeq.py`.

A.1.9 Making a Living from a Fortune

Suppose you want to live on a fortune F . You have invested the money in a safe way that gives an annual interest of p percent. Every year you plan to consume an amount c_n , where n counts years. The development of your fortune x_n from one year to the other can then be modeled by

$$x_n = x_{n-1} + \frac{p}{100}x_{n-1} - c_{n-1}, \quad x_0 = F. \quad (\text{A.30})$$

A simple example is to keep c constant, say q percent of the interest the first year:

$$x_n = x_{n-1} + \frac{p}{100}x_{n-1} - \frac{pq}{10^4}F, \quad x_0 = F. \quad (\text{A.31})$$

A more realistic model is to assume some inflation of I percent per year. You will then like to increase c_n by the inflation. We can extend the model in two ways. The simplest and clearest way, in the author's opinion, is to track the evolution of two sequences x_n and c_n :

$$x_n = x_{n-1} + \frac{p}{100}x_{n-1} - c_{n-1}, \quad x_0 = F, \quad c_0 = \frac{pq}{10^4}F, \quad (\text{A.32})$$

$$c_n = c_{n-1} + \frac{I}{100}c_{n-1}. \quad (\text{A.33})$$

This is a system of two difference equations with two unknowns. The solution method is, nevertheless, not much more complicated than the method for a difference equation in one unknown, since we can first compute x_n from (A.32) and then update the c_n value from (A.33). You are encouraged to write the program (see Exercise A.7).

Another way of making a difference equation for the case with inflation, is to use an explicit formula for c_{n-1} , i.e., solve (A.33) and end up with a formula like (A.4). Then we can insert the explicit formula

$$c_{n-1} = \left(1 + \frac{I}{100}\right)^{n-1} \frac{pq}{10^4}F$$

in (A.30), resulting in only one difference equation to solve.

A.1.10 Newton's Method

The difference equation

$$x_n = x_{n-1} - \frac{f(x_{n-1})}{f'(x_{n-1})}, \quad x_0 \text{ given}, \quad (\text{A.34})$$

generates a sequence x_n where, if the sequence converges (i.e., if $x_n - x_{n-1} \rightarrow 0$), x_n approaches a root of $f(x)$. That is, $x_n \rightarrow x$, where x solves the equation $f(x) = 0$. Equation (A.34) is the famous Newton's method for solving nonlinear algebraic equations $f(x) = 0$. When $f(x)$ is not linear, i.e., $f(x)$ is not on the form $ax + b$ with constant a and b , (A.34) becomes a *nonlinear difference equation*. This complicates analytical treatment of difference equations, but poses no extra difficulties for numerical solution.

We can quickly sketch the derivation of (A.34). Suppose we want to solve the equation

$$f(x) = 0$$

and that we already have an approximate solution x_{n-1} . If $f(x)$ were linear, $f(x) = ax + b$, it would be very easy to solve $f(x) = 0$: $x = -b/a$. The idea is therefore to approximate $f(x)$ in the vicinity of $x = x_{n-1}$ by a linear function, i.e., a straight line $f(x) \approx \tilde{f}(x) = ax + b$. This line should have the same slope as $f(x)$, i.e., $a = f'(x_{n-1})$, and both the line and f should have the same value at $x = x_{n-1}$. From this condition one can find $b = f(x_{n-1}) - x_{n-1}f'(x_{n-1})$. The approximate function (line) is then

$$\tilde{f}(x) = f(x_{n-1}) + f'(x_{n-1})(x - x_{n-1}). \quad (\text{A.35})$$

This expression is just the two first terms of a Taylor series approximation to $f(x)$ at $x = x_{n-1}$. It is now easy to solve $\tilde{f}(x) = 0$ with respect to x , and we get

$$x = x_{n-1} - \frac{f(x_{n-1})}{f'(x_{n-1})}. \quad (\text{A.36})$$

Since \tilde{f} is only an approximation to f , x in (A.36) is only an approximation to a root of $f(x) = 0$. Hopefully, the approximation is better than x_{n-1} so we set $x_n = x$ as the next term in a sequence that we hope converges to the correct root. However, convergence depends highly on the shape of $f(x)$, and there is no guarantee that the method will work.

The previous programs for solving difference equations have typically calculated a sequence x_n up to $n = N$, where N is given. When using (A.34) to find roots of nonlinear equations, we do not know a suitable N in advance that leads to an x_n where $f(x_n)$ is sufficiently close to zero. We therefore have to keep on increasing n until $f(x_n) < \epsilon$ for some small ϵ . Of course, the sequence diverges, we will keep on forever, so there must be some maximum allowable limit on n , which we may take as N .

It can be convenient to have the solution of (A.34) as a function for easy reuse. Here is a first rough implementation:

```
def Newton(f, x, dfdx, epsilon=1.0E-7, N=100):
    n = 0
    while abs(f(x)) > epsilon and n <= N:
        x = x - f(x)/dfdx(x)
        n += 1
    return x, n, f(x)
```

This function might well work, but $f(x)/dfdx(x)$ can imply integer division, so we should ensure that the numerator or denominator is of `float` type. There are also two function evaluations of $f(x)$ in every pass in the loop (one in the loop body and one in the `while` condition). We can get away with only one evaluation if we store the $f(x)$ in a local variable. In the small examples with $f(x)$ in the present course, twice as many function evaluations of f as necessary does not matter, but the same `Newton` function can in fact be used for much more complicated functions, and in those cases twice as much work can be noticeable. As a programmer, you should therefore learn to optimize the code by removing unnecessary computations.

Another, more serious, problem is the possibility dividing by zero. Almost as serious, is dividing by a very small number that creates a large value, which might cause Newton's method to diverge. Therefore, we should test for small values of $f'(x)$ and write a warning or raise an exception.

Another improvement is to add a boolean argument `store` to indicate whether we want the $(x, f(x))$ values during the iterations to be stored in a list or not. These intermediate values can be handy if we want to print out or plot the convergence behavior of Newton's method.

An improved `Newton` function can now be coded as

```
def Newton(f, x, dfdx, epsilon=1.0E-7, N=100, store=False):
    f_value = f(x)
    n = 0
    if store: info = [(x, f_value)]
    while abs(f_value) > epsilon and n <= N:
        dfdx_value = float(dfdx(x))
        if abs(dfdx_value) < 1E-14:
            raise ValueError("Newton: f'(%g)=%g" % (x, dfdx_value))

        x = x - f_value/dfdx_value

        n += 1
        f_value = f(x)
        if store: info.append((x, f_value))
    if store:
        return x, info
    else:
        return x, n, f_value
```

Note that to use the `Newton` function, we need to calculate the derivative $f'(x)$ and implement it as a Python function and provide it as the `dfdx` argument. Also note that what we return depends on whether we store $(x, f(x))$ information during the iterations or not.

It is quite common to test if $\text{dfdx}(x)$ is zero in an implementation of Newton's method, but this is not strictly necessary in Python since an exception `ZeroDivisionError` is always raised when dividing by zero.

We can apply the Newton function to solve the equation⁸ $e^{-0.1x^2} \sin(\frac{\pi}{2}x) = 0$:

```
from math import sin, cos, exp, pi
import sys
from Newton import Newton

def g(x):
    return exp(-0.1*x**2)*sin(pi/2*x)

def dg(x):
    return -2*0.1*x*exp(-0.1*x**2)*sin(pi/2*x) + \
        pi/2*exp(-0.1*x**2)*cos(pi/2*x)

x0 = float(sys.argv[1])
x, info = Newton(g, x0, dg, store=True)
print 'root:', x
for i in range(len(info)):
    print 'Iteration %3d: f(%g)=%g' % \
        (i, info[i][0], info[i][1])
```

The Newton function and this program can be found in the file `Newton.py`. Running this program with an initial x value of 1.7 results in the output

```
root: 1.999999999768449
Iteration 0: f(1.7)=0.340044
Iteration 1: f(1.99215)=0.00828786
Iteration 2: f(1.99998)=2.53347e-05
Iteration 3: f(2)=2.43808e-10
```

The convergence is fast towards the solution $x = 2$. The error is of the order 10^{-10} even though we stop the iterations when $f(x) \leq 10^{-7}$.

Trying a start value of 3 we would expect the method to find the root $x = 2$ or $x = 4$, but now we get

```
root: 42.49723316011362
Iteration 0: f(3)=-0.40657
Iteration 1: f(4.66667)=0.0981146
Iteration 2: f(42.4972)=-2.59037e-79
```

We have definitely solved $f(x) = 0$ in the sense that $|f(x)| \leq \epsilon$, where ϵ is a small value (here $\epsilon \sim 10^{-79}$). However, the solution $x \approx 42.5$ is *not* close to the solution ($x = 42$ and $x = 44$ are the solutions closest to the computed x). Can you use your knowledge of how the Newton method works and figure out why we get such strange behavior?

The demo program `Newton_movie.py` can be used to investigate the strange behavior. This program takes five command-line arguments: a formula for $f(x)$, a formula for $f'(x)$ (or the word `numeric`, which indicates a numerical approximation of $f'(x)$), a guess at the root, and

⁸ Fortunately you realize that the exponential function can never be zero, so the solutions of the equation must be the zeros of the sine function, i.e., $\frac{\pi}{2}x = i\pi$ for all integers $i = \dots, -2, 1, 0, 1, 2, \dots$. This gives $x = 2i$ as the solutions.

the minimum and maximum x values in the plots. We try the following case with the program:

```
Terminal
```

```
Newton_movie.py'exp(-0.1*x**2)*sin(pi/2*x)' numeric 3 -3 43
```

As seen, we start with $x = 3$ as the initial guess. In the first step of the method, we compute a new value of the root, now $x = 4.66667$. As we see in Figure A.3, this root is near an extreme point of $f(x)$ so that the derivative is small, and the resulting straight line approximation to $f(x)$ at this root becomes quite flat. The result is a new guess at the root: $x=42.5$. This root is far away from the last root, but the second problem is that $f(x)$ is quickly damped as we move to increasing x values, and at $x = 42.5$ f is small enough to fulfill the convergence criterion. Any guess at the root out in this region would satisfy that criterion.

You can run the `Newton_movie.py` program with other values of the initial root and observe that the method usually finds the nearest roots.

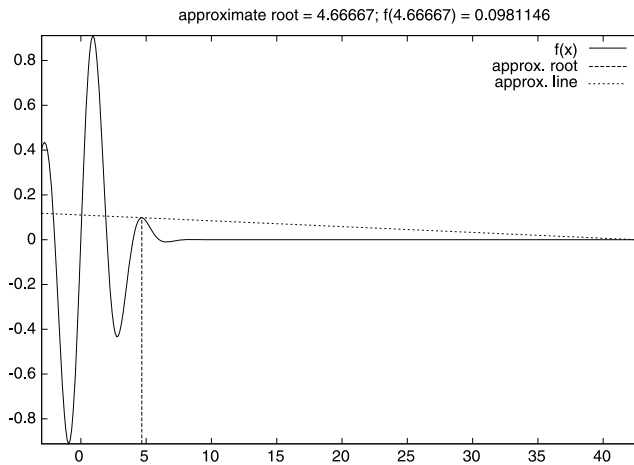

Fig. A.3 Failure of Newton's method to solve $e^{-0.1x^2} \sin(\frac{\pi}{2}x) = 0$. The plot corresponds to the second root found (starting with $x = 3$).

A.1.11 The Inverse of a Function

Given a function $f(x)$, the inverse function of f , say we call it $g(x)$, has the property that if we apply g to the value $f(x)$, we get x back:

$$g(f(x)) = x.$$

Similarly, if we apply f to the value $g(x)$, we get x :

$$f(g(x)) = x. \tag{A.37}$$

By hand, you substitute $g(x)$ by (say) y in (A.37) and solve (A.37) with respect to y to find some x expression for the inverse function. For example, given $f(x) = x^2 - 1$, we must solve $y^2 - 1 = x$ with respect to y . To ensure a unique solution for y , the x values have to be limited to an interval where $f(x)$ is monotone, say $x \in [0, 1]$ in the present example. Solving for y gives $y = \sqrt{1+x}$, therefore $g(x) = \sqrt{1+x}$. It is easy to check that $f(g(x)) = (\sqrt{1+x})^2 - 1 = x$.

Numerically, we can use the “definition” (A.37) of the inverse function g at one point at a time. Suppose we have a sequence of points $x_0 < x_1 < \dots < x_N$ along the x axis such that f is monotone in $[x_0, x_N]$: $f(x_0) > f(x_1) > \dots > f(x_N)$ or $f(x_0) < f(x_1) < \dots < f(x_N)$. For each point x_i , we have

$$f(g(x_i)) = x_i.$$

The value $g(x_i)$ is unknown, so let us call it γ . The equation

$$f(\gamma) = x_i \tag{A.38}$$

can be solved by respect γ . However, (A.38) is in general nonlinear if f is a nonlinear function of x . We must then use, e.g., Newton’s method to solve (A.38). Newton’s method works for an equation phrased as “ $f(x) = 0$ ”, which in our case is $f(\gamma) - x_i = 0$, i.e., we seek the roots of the function $F(\gamma) \equiv f(\gamma) - x_i$. Also the derivative $F'(\gamma)$ is needed in Newton’s method. For simplicity we may use an approximate finite difference:

$$\frac{dF}{d\gamma} \approx \frac{F(\gamma + h) - F(\gamma - h)}{2h}.$$

As start value γ_0 , we can use the previously computed g value: g_{i-1} . We introduce the short notation $\gamma = \text{Newton}(F, \gamma_0)$ to indicate the solution of $F(\gamma) = 0$ with initial guess γ_0 .

The computation of all the g_0, \dots, g_N values can now be expressed by

$$g_i = \text{Newton}(F, g_{i-1}), \quad i = 1, \dots, N, \tag{A.39}$$

and for the first point we may use x_0 as start value (for instance):

$$g_0 = \text{Newton}(F, x_0). \tag{A.40}$$

Equations (A.39)–(A.40) constitute a difference equation for g_i , since given g_{i-1} , we can compute the next element of the sequence by (A.39). Because (A.39) is a nonlinear equation in the new value g_i , and (A.39) is therefore an example of a *nonlinear difference equation*.

The following program computes the inverse function $g(x)$ of $f(x)$ at some discrete points x_0, \dots, x_N . Our sample function is $f(x) = x^2 - 1$:

```
from Newton import Newton
from scitools.std import *

def f(x):
```

```

    return x**2 - 1

def F(gamma):
    return f(gamma) - xi

def dFdx(gamma):
    return (F(gamma+h) - F(gamma-h))/(2*h)

h = 1E-6
x = linspace(0.01, 3, 21)
g = zeros(len(x))

for i in range(len(x)):
    xi = x[i]

    # Compute start value (use last g[i-1] if possible)
    if i == 0:
        gamma0 = x[0]
    else:
        gamma0 = g[i-1]

    gamma, n, F_value = Newton(F, gamma0, dFdx)
    g[i] = gamma

plot(x, f(x), 'r-', x, g, 'b-',
      title='f1', legend=('original', 'inverse'))

```

Note that with $f(x) = x^2 - 1$, $f'(0) = 0$, so Newton's method divides by zero and breaks down unless with let $x_0 > 0$, so here we set $x_0 = 0.01$. The `f` function can easily be edited to let the program compute the inverse of another function. The `F` function can remain the same since it applies a general finite difference to approximate the derivative of the `f(x)` function. The complete program is found in the file `inverse_function.py`. A better implementation is suggested in Exercise 7.26.

A.2 Programming with Sound

Sound on a computer is nothing but a sequence of numbers. As an example, consider the famous A tone at 440 Hz. Physically, this is an oscillation of a tuning fork, loudspeaker, string or another mechanical medium that makes the surrounding air also oscillate and transport the sound as a compression wave. This wave may hit our ears and through complicated physiological processes be transformed to an electrical signal that the brain can recognize as sound. Mathematically, the oscillations are described by a sine function of time:

$$s(t) = A \sin(2\pi ft), \quad (\text{A.41})$$

where A is the amplitude or strength of the sound and f is the frequency (440 Hz for the A in our example). In a computer, $s(t)$ is represented at discrete points of time. CD quality means 44100 samples per second. Other sample rates are also possible, so we introduce r as the sample

rate. An f Hz tone lasting for m seconds with sample rate r can then be computed as the sequence

$$s_n = A \sin\left(2\pi f \frac{n}{r}\right), \quad n = 0, 1, \dots, m \cdot r. \quad (\text{A.42})$$

With Numerical Python this computation is straightforward and very efficient. Introducing some more explanatory variable names than r , A , and m , we can write a function for generating a note:

```
import numpy
def note(frequency, length, amplitude=1, sample_rate=44100):
    time_points = numpy.linspace(0, length, length*sample_rate)
    data = numpy.sin(2*numpy.pi*frequency*time_points)
    data = amplitude*data
    return data
```

A.2.1 Writing Sound to File

The `note` function above generates an array of `float` data representing a note. The sound card in the computer cannot play these data, because the card assumes that the information about the oscillations appears as a sequence of two-byte integers. With an array's `astype` method we can easily convert our data to two-byte integers instead of `floats`:

```
data = data.astype(numpy.int16)
```

That is, the name of the two-byte integer data type in `numpy` is `int16` (two bytes are 16 bits). The maximum value of a two-byte integer is $2^{15} - 1$, so this is also the maximum amplitude. Assuming that `amplitude` in the `note` function is a relative measure of intensity, such that the value lies between 0 and 1, we must adjust this amplitude to the scale of two-byte integers:

```
max_amplitude = 2**15 - 1
data = max_amplitude*data
```

The `data` array of `int16` numbers can be written to a file and played as an ordinary file in CD quality. Such a file is known as a wave file or simply a WAV file since the extension is `.wav`. Python has a module `wave` for creating such files. Given an array of sound, `data`, we have in SciTools a module `sound` with a function `write` for writing the data to a WAV file (using functionality from the `wave` module):

```
import scitools.sound
scitools.sound.write(data, 'Atone.wav')
```

You can now use your favorite music player to play the `Atone.wav` file, or you can play it from within a Python program using

```
scitools.sound.play('Atone.wav')
```

The `write` function can take more arguments and write, e.g., a stereo file with two channels, but we do not dive into these details here.

A.2.2 Reading Sound from File

Given a sound signal in a WAV file, we can easily read this signal into an array and mathematically manipulate the data in the array to change the flavor of the sound, e.g., add echo, treble, or bass. The recipe for reading a WAV file with name `filename` is

```
data = scitools.sound.read(filename)
```

The `data` array has elements of type `int16`. Often we want to compute with this array, and then we need elements of `float` type, obtained by the conversion

```
data = data.astype(float)
```

The `write` function automatically transforms the element type back to `int16` if we have not done this explicitly.

One operation that we can easily do is adding an echo. Mathematically this means that we add a damped delayed sound, where the original sound has weight β and the delayed part has weight $1 - \beta$, such that the overall amplitude is not altered. Let d be the delay in seconds. With a sampling rate r the number of indices in the delay becomes dr , which we denote by b . Given an original sound sequence s_n , the sound with echo is the sequence

$$e_n = \beta s_n + (1 - \beta) s_{n-b}. \quad (\text{A.43})$$

We cannot start n at 0 since $e_0 = s_{0-b} = s_{-b}$ which is a value outside the sound data. Therefore we define $e_n = s_n$ for $n = 0, 1, \dots, b$, and add the echo thereafter. A simple loop can do this (again we use descriptive variable names instead of the mathematical symbols introduced):

```
def add_echo(data, beta=0.8, delay=0.002, sample_rate=44100):
    newdata = data.copy()
    shift = int(delay*sample_rate) # b (math symbol)
    for i in range(shift, len(data)):
        newdata[i] = beta*data[i] + (1-beta)*data[i-shift]
    return newdata
```

The problem with this function is that it runs slowly, especially when we have sound clips lasting several seconds (recall that for CD quality we need 44100 numbers per second). It is therefore necessary to vectorize the implementation of the difference equation for adding echo. The update is then based on adding slices:

```
newdata[shift:] = beta*data[shift:] + \
                (1-beta)*data[:len(data)-shift]
```

A.2.3 Playing Many Notes

How do we generate a melody mathematically in a computer program? With the `note` function we can generate a note with a certain amplitude, frequency, and duration. The note is represented as an array. Putting sound arrays for different notes after each other will make up a melody. If we have several sound arrays `data1`, `data2`, `data3`, ..., we can make a new array consisting of the elements in the first array followed by the elements of the next array followed by the elements in the next array and so forth:

```
data = numpy.concatenate((data1, data2, data3, ...))
```

Here is an example of creating a little melody (start of “Nothing Else Matters” by Metallica) using constant (max) amplitude of all the notes:

```
E1 = note(164.81, .5)
G = note(392, .5)
B = note(493.88, .5)
E2 = note(659.26, .5)
intro = numpy.concatenate((E1, G, B, E2, B, G))
high1_long = note(987.77, 1)
high1_short = note(987.77, .5)
high2 = note(1046.50, .5)
high3 = note(880, .5)
high4_long = note(659.26, 1)
high4_medium = note(659.26, .5)
high4_short = note(659.26, .25)
high5 = note(739.99, .25)
pause_long = note(0, .5)
pause_short = note(0, .25)
song = numpy.concatenate(
    (intro, intro, high1_long, pause_long, high1_long,
     pause_long, pause_long,
     high1_short, high2, high1_short, high3, high1_short,
     high3, high4_short, pause_short, high4_long, pause_short,
     high4_medium, high5, high4_short))
song *= max_amplitude
scitools.sound.play(song)
scitools.sound.write(song, 'tmp.wav')
```

We could send `song` to the `add_echo` function to get some echo, and we could also vary the amplitudes to get more dynamics into the song. You can find the generation of notes above as the function `Nothing_Else_Matters(echo=False)` in the `scitools.sound` module.

A.2.4 Music of a Sequence

Problem. The purpose of this example is to listen to the sound generated by two mathematical sequences. The first one is given by an

explicit formula, constructed to oscillate around 0 with decreasing amplitude:

$$x_n = e^{-4n/N} \sin(8\pi n/N). \quad (\text{A.44})$$

The other sequence is generated by the difference equation (A.13) for logistic growth, repeated here for convenience:

$$x_n = x_{n-1} + qx_{n-1}(1 - x_{n-1}), \quad x = x_0. \quad (\text{A.45})$$

We let $x_0 = 0.01$ and $q = 2$. This leads to fast initial growth toward the limit 1, and then oscillations around this limit (this problem is studied in Exercise A.23).

The absolute value of the sequence elements x_n are of size between 0 and 1, approximately. We want to transform these sequence elements to tones, using the techniques of Appendix A.2. First we convert x_n to a frequency the human ear can hear. The transformation

$$y_n = 440 + 200x_n \quad (\text{A.46})$$

will make a standard A reference tone out of $x_n = 0$, and for the maximum value of x_n around 1 we get a tone of 640 Hz. Elements of the sequence generated by (A.44) lie between -1 and 1 , so the corresponding frequencies lie between 240 Hz and 640 Hz. The task now is to make a program that can generate and play the sounds.

Solution. Tones can be generated by the `note` function from the `scitools.sound` module. We collect all tones corresponding to all the y_n frequencies in a list `tones`. Letting `N` denote the number of sequence elements, the relevant code segment reads

```
from scitools.sound import *
freqs = 440 + x*200
tones = []
duration = 30.0/N      # 30 sec sound in total
for n in range(N+1):
    tones.append(max_amplitude*note(freqs[n], duration, 1))
data = concatenate(tones)
write(data, filename)
data = read(filename)
play(filename)
```

It is illustrating to plot the sequences too,

```
plot(range(N+1), freqs, 'ro')
```

To generate the sequences (A.44) and (A.45), we make two functions, `oscillations` and `logistic`, respectively. These functions take the number of sequence elements (`N`) as input and return the sequence stored in an array.

In another function `make_sound` we compute the sequence, transform the elements to frequencies, generate tones, write the tones to file, and play the sound file.

As always, we collect the functions in a module and include a test block where we can read the choice of sequence and the sequence length from the command line. The complete module file look as follows:

```

from scitools.sound import *
from scitools.std import *

def oscillations(N):
    x = zeros(N+1)
    for n in range(N+1):
        x[n] = exp(-4*n/float(N))*sin(8*pi*n/float(N))
    return x

def logistic(N):
    x = zeros(N+1)
    x[0] = 0.01
    q = 2
    for n in range(1, N+1):
        x[n] = x[n-1] + q*x[n-1]*(1 - x[n-1])
    return x

def make_sound(N, seqtype):
    filename = 'tmp.wav'
    x = eval(seqtype)(N)
    # Convert x values to frequencies around 440
    freqs = 440 + x*200
    plot(range(N+1), freqs, 'ro')
    # Generate tones
    tones = []
    duration = 30.0/N      # 30 sec sound in total
    for n in range(N+1):
        tones.append(max_amplitude*note(freqs[n], duration, 1))
    data = concatenate(tones)
    write(data, filename)
    data = read(filename)
    play(filename)

if __name__ == '__main__':
    try:
        seqtype = sys.argv[1]
        N = int(sys.argv[2])
    except IndexError:
        print 'Usage: %s oscillations|logistic N' % sys.argv[0]
        sys.exit(1)
    make_sound(N, seqtype)

```

This code should be quite easy to read at the present stage in the book. However, there is one statement that deserves a comment:

```
x = eval(seqtype)(N)
```

The `seqtype` argument reflects the type of sequence and is a string that the user provides on the command line. The values of the string equal the function names `oscillations` and `logistic`. With `eval(seqtype)` we turn the string into a function name. For example, if `seqtype` is `'logistic'`, performing an `eval(seqtype)(N)` is the same as if we had written `logistic(N)`. This technique allows the user of the program to choose a function call inside the code. Without `eval` we would need to explicitly test on values:

```

if seqtype == 'logistic':
    x = logistic(N)
elif seqtype == 'oscillations':
    x = oscillations(N)

```

This is not much extra code to write in the present example, but if we have a large number of functions generating sequences, we can save a lot of boring if-else code by using the `eval` construction.

The next step, as a reader who have understood the problem and the implementation above, is to run the program for two cases: the `oscillations` sequence with $N = 40$ and the `logistic` sequence with $N = 100$. By altering the q parameter to lower values, you get other sounds, typically quite boring sounds for non-oscillating logistic growth ($q < 1$). You can also experiment with other transformations of the form (A.46), e.g., increasing the frequency variation from 200 to 400.

A.3 Exercises

Exercise A.1. *Determine the limit of a sequence.*

Given the sequence

$$a_n = \frac{7 + 1/n}{3 - 1/n^2},$$

make a program that computes and prints out a_n for $n = 1, 2, \dots, N$. Read N from the command line. Does a_n approach a finite limit when $n \rightarrow \infty$? Name of program file: `sequence_limit1.py`. \diamond

Exercise A.2. *Determine the limit of a sequence.*

Solve Exercise A.1 when the sequence of interest is given by

$$D_n = \frac{\sin(2^{-n})}{2^{-n}}.$$

Name of program file: `sequence_limit2.py`. \diamond

Exercise A.3. *Experience convergence problems.*

Given the sequence

$$D_n = \frac{f(x+h) - f(x)}{h}, \quad h = 2^{-n} \quad (\text{A.47})$$

make a function `D(f, x, N)` that takes a function $f(x)$, a value x , and the number N of terms in the sequence as arguments, and returns an array with the D_n values for $n = 0, 1, \dots, N - 1$. Make a call to the `D` function with $f(x) = \sin x$, $x = 0$, and $N = 80$. Plot the evolution of the computed D_n values, using small circles for the data points.

Make another call to `D` where $x = \pi$ and plot this sequence in a separate figure. What would be your expected limit? Why do the com-

putations go wrong for large N ? (Hint: Print out the numerator and denominator in D_n .) Name of program file: `sequence_limits3.py`. \diamond

Exercise A.4. *Compute π via sequences.*

The following sequences all converge to π :

$$\begin{aligned} (a_n)_{n=1}^\infty, \quad a_n &= 4 \sum_{k=1}^n \frac{(-1)^{k+1}}{2k-1}, \\ (b_n)_{n=1}^\infty, \quad b_n &= \left(6 \sum_{k=1}^n k^{-2} \right)^{1/2}, \\ (c_n)_{n=1}^\infty, \quad c_n &= \left(90 \sum_{k=1}^n k^{-4} \right)^{1/4}, \\ (d_n)_{n=1}^\infty, \quad d_n &= \frac{6}{\sqrt{3}} \sum_{k=0}^n \frac{(-1)^k}{3^k(2k+1)}, \\ (e_n)_{n=1}^\infty, \quad e_n &= 16 \sum_{k=0}^n \frac{(-1)^k}{5^{2k+1}(2k+1)} - 4 \sum_{k=0}^n \frac{(-1)^k}{239^{2k+1}(2k+1)}. \end{aligned}$$

Make a function for each sequence that returns an array with the elements in the sequence. Plot all the sequences, and find the one that converges fastest toward the limit π . Name of program file: `pi.py`. \diamond

Exercise A.5. *Reduce memory usage of difference equations.*

Consider the program `growth_years.py` from Appendix A.1.1. Since x_n depends on x_{n-1} only, we do not need to store all the $N+1$ x_n values. We actually only need to store x_n and its previous value x_{n-1} . Modify the program to use two variables for x_n and not an array. Also avoid the `index_set` list and use an integer counter for n and a `while` instead. (Of course, without the arrays it is not possible to plot the development of x_n , so you have to remove the `plot` call.) Name of program file: `growth_years_efficient.py`. \diamond

Exercise A.6. *Compute the development of a loan.*

Solve (A.16)–(A.17) for $n = 1, 2, \dots, N$ in a Python function. Name of program file: `loan.py`. \diamond

Exercise A.7. *Solve a system of difference equations.*

Solve (A.32)–(A.33) by generating the x_n and c_n sequences in a Python function. Let the function return the computed sequences as arrays. Plot the x_n sequence. Name of program file: `fortune_and_inflation1.py`. \diamond

Exercise A.8. *Extend the model (A.32)–(A.33).*

In the model (A.32)–(A.33) the new fortune is the old one, plus the interest, minus the consumption. During year n , x_n is normally also

reduced with t percent tax on the earnings $x_{n-1} - x_{n-2}$ in year $n - 1$. Extend the model with an appropriate tax term, modify the program from Exercise A.7, and plot x_n with tax ($t = 28$) and without tax ($t = 0$). Name of program file: `fortune_and_inflation2.py`. \diamond

Exercise A.9. *Experiment with the program from Exer. A.8.*

Suppose you expect to live for N years and can accept that the fortune x_n vanishes after N years. Experiment with the program from Exercise A.8 for how large the initial c_0 can be in this case. Choose some appropriate values for p , q , I , and t . Name of program file: `fortune_and_inflation3.py`. \diamond

Exercise A.10. *Change index in a difference equation.*

A mathematically equivalent equation to (A.5) is

$$x_{i+1} = x_i + \frac{p}{100}x_i, \quad (\text{A.48})$$

since the name of the index can be chosen arbitrarily. Suppose someone has made the following program for solving (A.48) by a slight editing of the program `growth1.py`:

```
from scitools.std import *
x0 = 100           # initial amount
p = 5             # interest rate
N = 4             # number of years
index_set = range(N+1)
x = zeros(len(index_set))

# Compute solution
x[0] = x0
for i in index_set[1:]:
    x[i+1] = x[i] + (p/100.0)*x[i]
print x
plot(index_set, x, 'ro', xlabel='years', ylabel='amount')
```

This program does not work. Make a correct version, but keep the difference equations in its present form with the indices $i+1$ and i . Name of program file: `growth1_index_ip1.py`. \diamond

Exercise A.11. *Construct time points from dates.*

A certain quantity p (which may be an interest rate) is piecewise constant and undergoes changes at some specific dates, e.g.,

$$p \text{ changes to } \begin{cases} 4.5 & \text{on Jan 4, 2009} \\ 4.75 & \text{on March 21, 2009} \\ 6.0 & \text{on April 1, 2009} \\ 5.0 & \text{on June 30, 2009} \\ 4.5 & \text{on Nov 1, 2009} \\ 2.0 & \text{on April 1, 2010} \end{cases} \quad (\text{A.49})$$

Given a start date d_1 and an end date d_2 , fill an array p with the right p values, where the array index counts days. Use the `datetime` module

to compute the number of days between dates. Name of program file: `dates2days.py`. \diamond

Exercise A.12. *Solve nonlinear equations by Newton's method.*

Import the `Newton` function from the `Newton.py` file from Appendix A.1.10 to solve the following nonlinear algebraic equations:

$$\sin x = 0, \quad (\text{A.50})$$

$$x = \sin x, \quad (\text{A.51})$$

$$x^5 = \sin x, \quad (\text{A.52})$$

$$x^4 \sin x = 0, \quad (\text{A.53})$$

$$x^4 = 0, \quad (\text{A.54})$$

$$x^{10} = 0, \quad (\text{A.55})$$

$$\tanh x = x^{10}. \quad (\text{A.56})$$

Implement the $f(x)$ and $f'(x)$ functions, required by Newton's method, for each of the nonlinear equations. Collect the names of the $f(x)$ and $f'(x)$ in a list, and make a `for` loop over this list to call the `Newton` function for each equation. Read the starting point x_0 from the command line. Print out the evolution of the roots (based on the `info` list) for each equation. You will need to carefully plot the various $f(x)$ functions to understand how Newton's method will behave in each case for different starting values. Find a starting value x_0 value for each equation so that Newton's method will converge toward the root $x = 0$. Name of program file: `Newton_examples.py`. \diamond

Exercise A.13. *Visualize the convergence of Newton's method.*

Let x_0, x_1, \dots, x_N be the sequence of roots generated by Newton's method applied to a nonlinear algebraic equation $f(x) = 0$ (cf. Appendix A.1.10). In this exercise, the purpose is to plot the sequences $(x_n)_{n=0}^N$ and $(|f(x_n)|)_{n=0}^N$. Make a general function `Newton_plot(f, x, dfdx, epsilon=1E-7)` for this purpose. The arguments `f` and `dfdx` are Python functions representing the $f(x)$ function in the equation and its derivative $f'(x)$, respectively. Newton's method is run until $|f(x_N)| \leq \epsilon$, and the ϵ value is stored in the `epsilon` argument. The `Newton_plot` function should make two separate plots of $(x_n)_{n=0}^N$ and $(|f(x_n)|)_{n=0}^N$ on the screen and also save these plots to PNG files. Because of the potentially wide scale of values that $|f(x_n)|$ may exhibit, it may be wise to use a logarithmic scale on the y axis. (Hint: You can save quite some coding by calling the improved `Newton` function from Appendix A.1.10, which is available in the `Newton` module in `src/diffeq/Newton.py`.)

Demonstrate the function on the equation $x^6 \sin \pi x = 0$, with $\epsilon = 10^{-13}$. Try different starting values for Newton's method: $x_0 = -2.6, -1.2, 1.5, 1.7, 0.6$. Compare the results with the exact solutions $x = \dots, -2, -1, 0, 1, 2, \dots$. Name of program file: `Newton2.py`. \diamond

Exercise A.14. *Implement the Secant method.*

Newton's method (A.34) for solving $f(x) = 0$ requires the derivative of the function $f(x)$. Sometimes this is difficult or inconvenient. The derivative can be approximated using the last two approximations to the root, x_{n-2} and x_{n-1} :

$$f'(x_{n-1}) \approx \frac{f(x_{n-1}) - f(x_{n-2})}{x_{n-1} - x_{n-2}}.$$

Using this approximation in (A.34) leads to the Secant method:

$$x_n = x_{n-1} - \frac{f(x_{n-1})(x_{n-1} - x_{n-2})}{f(x_{n-1}) - f(x_{n-2})}, \quad x_0, x_1 \text{ given.} \quad (\text{A.57})$$

Here $n = 2, 3, \dots$. Make a program that applies the Secant method to solve $x^5 = \sin x$. Name of program file: `Secant.py`. \diamond

Exercise A.15. *Test different methods for root finding.*

Make a program for solving $f(x) = 0$ by Newton's method (Appendix A.1.10), the Bisection method (Chapter 4.6.2), and the Secant method (Exercise A.14). For each method, the sequence of root approximations should be written out (nicely formatted) on the screen. Read $f(x)$, $f'(x)$, a , b , x_0 , and x_1 from the command line. Newton's method starts with x_0 , the Bisection method starts with the interval $[a, b]$, whereas the Secant method starts with x_0 and x_1 .

Run the program for each of the equations listed in Exercise A.12. You should first plot the $f(x)$ functions as suggested in that exercise so you know how to choose x_0 , x_1 , a , and b in each case. Name of program file: `root_finder_examples.py`. \diamond

Exercise A.16. *Make difference equations for the Midpoint rule.*

Use the ideas of Appendix A.1.7 to make a similar system of difference equations and corresponding implementation for the Midpoint integration rule from Exercise 3.8. Name of program file: `diffeq_midpoint.py`. \diamond

Exercise A.17. *Compute the arc length of a curve.*

Sometimes one wants to measure the length of a curve $y = f(x)$ for $x \in [a, b]$. The arc length from $f(a)$ to some point $f(x)$ is denoted by $s(x)$ and defined through an integral

$$s(x) = \int_a^x \sqrt{1 + [f'(\xi)]^2} d\xi. \quad (\text{A.58})$$

We can compute $s(x)$ via difference equations as explained in Appendix A.1.7. Make a Python function `arclength(f, a, b, n)` that returns an array `s` with $s(x)$ values for n uniformly spaced coordinates x in $[a, b]$. Here `f(x)` is the Python implementation of the function that

defines the curve we want to compute the arc length of. How can you test that the `arclength` function works correctly? Test the function on

$$f(x) = \int_{-2}^x = \frac{1}{\sqrt{2\pi}} e^{-4t^2} dt, \quad x \in [-2, 2].$$

Compute $f(x)$ and plot it together with $s(x)$. Name of program file: `arclength.py`. \diamond

Exercise A.18. *Find difference equations for computing $\sin x$.*

The purpose of this exercise is to derive and implement difference equations for computing a Taylor polynomial approximation to $\sin x$, using the same ideas as in (A.24)–(A.25) for a Taylor polynomial approximation to e^x in Appendix A.1.8.

The Taylor series for $\sin x$ is presented in Exercise 5.21, Equation (5.21) on page 248. To compute $S(x; n)$ efficiently, we try to compute a new term from the last computed term. Let $S(x; n) = \sum_{j=0}^n a_j$, where the expression for a term a_j follows from the formula (5.21). Derive the following relation between two consecutive terms in the series,

$$a_j = -\frac{x^2}{(2j+1)2j} a_{j-1}. \quad (\text{A.59})$$

Introduce $s_j = S(x; j-1)$ and define $s_0 = 0$. We use s_j to accumulate terms in the sum. For the first term we have $a_0 = x$. Formulate a system of two difference equations for s_j and a_j in the spirit of (A.24)–(A.25). Implement this system in a function `sine_Taylor(x, n)`, which returns s_{n+1} and $|a_{n+1}|$. The latter is the first neglected term in the sum (since $s_{n+1} = \sum_{j=0}^n a_j$) and may act as a rough measure of the size of the error in the approximation.

Verify the implementation by computing the difference equations for $n = 2$ by hand (or in a separate program) and comparing with the output from the `sine_Taylor` function. Also make a table of s_n for various x and n values to verify that the accuracy of a Taylor polynomial improves as n increases and x decreases. Be aware of the fact that `sine_Taylor(x, n)` can give extremely inaccurate approximations to $\sin x$ if x is not sufficiently small and n sufficiently large. Name of program file: `sin_Taylor_series_diffeq.py`. \diamond

Exercise A.19. *Find difference equations for computing $\cos x$.*

Carry out the steps in Exercise A.18, but do it for the Taylor series of $\cos x$ instead of $\sin x$ (look up the Taylor series for $\cos x$ in a mathematics textbook or search on the Internet). Name of program file: `cos_Taylor_series_diffeq.py`. \diamond

Exercise A.20. *Make a guitar-like sound.*

Given start values x_0, x_1, \dots, x_p , the following difference equation is known to create guitar-like sound:

$$x_n = \frac{1}{2}(x_{n-p} + x_{n-p-1}), \quad n = p + 1, \dots, N. \quad (\text{A.60})$$

With a sampling rate r , the frequency of this sound is given by r/p . Make a program with a function `solve(x, p)` which returns the solution array \mathbf{x} of (A.60). To initialize the array `x[0:p+1]` we look at two methods, which can be implemented in two alternative functions:

1. $x_0 = 1, x_1 = x_2 = \dots = x_p = 0$
2. x_0, \dots, x_p are uniformly distributed random numbers in $[-1, 1]$

Import `max_amplitude`, `write`, and `play` from the `scitools.sound` module. Choose a sampling rate r and set $p = r/440$ to create a 440 Hz tone (A). Create an array `x1` of zeros with length $3r$ such that the tone will last for 3 seconds. Initialize `x1` according to method 1 above and solve (A.60). Multiply the `x1` array by `max_amplitude`. Repeat this process for an array `x2` of length $2r$, but use method 2 for the initial values and choose p such that the tone is 392 Hz (G). Concatenate `x1` and `x2`, call `write` and then `play` to play the sound. As you will experience, this sound is amazingly similar to the sound of a guitar string, first playing A for 3 seconds and then playing G for 2 seconds. (The method (A.60) is called the Karplus-Strong algorithm and was discovered in 1979 by a researcher, Kevin Karplus, and his student Alexander Strong, at Stanford University.) Name of program file: `guitar_sound.py`. \diamond

Exercise A.21. *Damp the bass in a sound file.*

Given a sequence x_0, \dots, x_{N-1} , the following *filter* transforms the sequence to a new sequence y_0, \dots, y_{N-1} :

$$y_n = \begin{cases} x_n, & n = 0 \\ -\frac{1}{4}(x_{n-1} - 2x_n + x_{n+1}), & 1 \leq n \leq N - 2 \\ x_n, & n = N - 1 \end{cases} \quad (\text{A.61})$$

If x_n represents sound, y_n is the same sound but with the bass damped. Load some sound file (e.g., the one from Exercise A.20) or call

```
x = scitools.sound.Nothing_Else_Matters(echo=True)
```

to get a sound sequence. Apply the filter (A.61) and play the resulting sound. Plot the first 300 values in the x_n and y_n signals to see graphically what the filter does with the signal. Name of program file: `damp_bass.py`. \diamond

Exercise A.22. *Damp the treble in a sound file.*

Solve Exercise A.21 to get some experience with coding a filter and trying it out on a sound. The purpose of this exercise is to explore some other filters that reduce the treble instead of the bass. Smoothing the sound signal will in general damp the treble, and smoothing is typically obtained by letting the values in the new filtered sound sequence be an average of the neighboring values in the original sequence.

The simplest smoothing filter can apply a standard average of three neighboring values:

$$y_n = \begin{cases} x_n, & n = 0 \\ \frac{1}{3}(x_{n-1} + x_n + x_{n+1}), & 1 \leq n \leq N - 2 \\ x_n, & n = N - 1 \end{cases} \quad (\text{A.62})$$

Two other filters put less emphasis on the surrounding values:

$$y_n = \begin{cases} x_n, & n = 0 \\ \frac{1}{4}(x_{n-1} + 2x_n + x_{n+1}), & 1 \leq n \leq N - 2 \\ x_n, & n = N - 1 \end{cases} \quad (\text{A.63})$$

$$y_n = \begin{cases} x_n, & n = 0, 1 \\ \frac{1}{16}(x_{n-2} + 4x_{n-1} + 6x_n + 4x_{n+1} + x_{n+2}), & 2 \leq n \leq N - 3 \\ x_n, & n = N - 2, N - 1 \end{cases} \quad (\text{A.64})$$

Apply all these three filters to a sound file and listen to the result. Plot the first 300 values in the x_n and y_n signals for each of the three filters to see graphically what the filter does with the signal. Name of program file: `damp_treble.py`. \diamond

Exercise A.23. *Demonstrate oscillatory solutions of (A.13).*

Modify the `growth_logistic.py` program from Appendix A.1.5 to solve the equation (A.13) on page 566. Read the input parameters y_0 , q , and N from the command line.

Equation (A.13) has the solution $y_n = 1$ as $n \rightarrow \infty$. Demonstrate, by running the program, that this is the case when $y_0 = 0.3$, $q = 1$, and $N = 50$.

For larger q values, y_n does not approach a constant limit, but y_n oscillates instead around the limiting value. Such oscillations are sometimes observed in wildlife populations. Demonstrate oscillatory solutions when q is changed to 2 and 3.

It could happen that y_n stabilizes at a constant level for larger N . Demonstrate that this is not the case by running the program with $N = 1000$. Name of program file: `growth_logistic2.py`. \diamond

Exercise A.24. *Improve the program from Exer. A.23.*

It is tedious to run a program like the one from Exercise A.23 repeatedly for a wide range of input parameters. A better approach is to let the computer do the manual work. Modify the program from Exercise A.23 such that the computation of y_n and the plot is made in a function. Let the title in the plot contain the parameters y_0 and q (N is easily visible from the x axis). Also let the name of the plot file reflect the values of y_0 , q , and N . Then make loops over y_0 and q to perform the following more comprehensive set of experiments:

- $y_0 = 0.01, 0.3$

- $q = 0.1, 1, 1.5, 1.8, 2, 2.5, 3$
- $N = 50$

How does the initial condition (the value y_0) seem to influence the solution?

The keyword argument `show=False` can be used in the `plot` call if you do not want all the plot windows to appear on the screen. Name of program file: `growth_logistic3.py`. \diamond

Exercise A.25. *Generate an HTML report.*

Extend the program made in Exercise A.24 with a report containing all the plots. The report can be written in HTML and displayed by a web browser. The plots must then be generated in PNG format. The source of the HTML file will typically look as follows:

```
<html>
<body>
<p>
<p>
<p>
<p>
...
<p>
</html>
</body>
```

Let the program write out the HTML text, either to the screen or to a file (cf. Chapter 6.5). When writing to the screen, redirect the output to a file,

```
Terminal
```

```
growth_logistic4.py > report.html
```

The file `report.html` can be loaded into a web browser.

You may let the function making the plots return the name of the plotfile such that this string can be inserted in the HTML file. Name of program file: `growth_logistic4.py`. \diamond

Exercise A.26. *Simulate the price of wheat.*

The demand for wheat in year t is given by

$$D_t = ap_t + b,$$

where $a < 0, > 0$, and p_t is the price of wheat. Let the supply of wheat be

$$S_t = Ap_{t-1} + B + \ln(1 + p_{t-1}),$$

where A and B are given constants. We assume that the price p_t adjusts such that all the produced wheat is sold. That is, $D_t = S_t$.

For $A = 1, a = -3, b = 5, B = 0$, find from numerical computations, a stable price such that the production of wheat from year to year is constant. That is, find p such that $ap + b = Ap + B + \ln(1 + p)$.

Assume that in a very dry year the production of wheat is much less than planned. Given that price this year, p_0 , is 4.5 and $D_t = S_t$, com-

pute in a program how the prices p_1, p_2, \dots, p_N develop. This implies solving the difference equation

$$ap_t + b = Ap_{t-1} + B + \ln(1 + p_{t-1}).$$

From the p_t values, compute S_t and plot the points (p_t, S_t) for $t = 0, 1, 2, \dots, N$. How do the prices move when $N \rightarrow \infty$? Name of program file: `wheat.py`. \diamond

This Appendix is Authored by Aslak Tveito

In this chapter we will discuss how to differentiate and integrate functions on a computer. To do that, we have to care about how to treat mathematical functions on a computer. Handling mathematical functions on computers is not entirely straightforward: A function $f(x)$ contains an infinite amount of information (function values at an infinite number of x values on an interval), while the computer can only store a finite¹ amount of data. Think about the $\cos x$ function. There are typically two ways we can work with this function on a computer. One way is to run an algorithm, like that in Exercise 3.30 on page 130, or we simply call `math.cos(x)` (which runs a similar type of algorithm), to compute an approximation to $\cos x$ for a given x , using a finite number of calculations. The other way is to store $\cos x$ values in a table for a finite number of x values² and use the table in a smart way to compute $\cos x$ values. This latter way, known as a *discrete* representation of a function, is in focus in the present chapter. With a discrete function representation, we can easily integrate and differentiate the function too. Read on to see how we can do that.

The folder `src/discrete` contains all the program example files referred to in this chapter.

B.1 Discrete Functions

Physical quantities, such as temperature, density, and velocity, are usually defined as continuous functions of space and time. However, as

¹ Allow yourself a moment or two to think about the terms “finite” and “infinite”; infinity is not an easy term, but it is not infinitely difficult. Or is it?

² Of course, we need to run an algorithm to populate the table with $\cos x$ numbers.

mentioned in above, discrete versions of the functions are more convenient on computers. We will illustrate the concept of discrete functions through some introductory examples. In fact, we used discrete functions in Chapter 5 to plot curves: We defined a finite set of coordinates \mathbf{x} and stored the corresponding function values $\mathbf{f}(\mathbf{x})$ in an array. A plotting program would then draw straight lines between the function values. A discrete representation of a continuous function is, from a programming point of view, nothing but storing a finite set of coordinates and function values in an array. Nevertheless, we will in this chapter be more formal and describe discrete functions by precise mathematical terms.

B.1.1 The Sine Function

Suppose we want to generate a plot of the sine function for values of x between 0 and π . To this end, we define a set of x -values and an associated set of values of the sine function. More precisely, we define $n + 1$ points by

$$x_i = ih \text{ for } i = 0, 1, \dots, n \quad (\text{B.1})$$

where $h = \pi/n$ and $n \geq 1$ is an integer. The associated function values are defined as

$$s_i = \sin(x_i) \text{ for } i = 0, 1, \dots, n. \quad (\text{B.2})$$

Mathematically, we have a sequence of coordinates $(x_i)_{i=0}^n$ and of function values $(s_i)_{i=0}^n$ (see the start of Appendix A for an explanation of the notation and the sequence concept). Often we “merge” the two sequences to one sequence of points: $(x_i, s_i)_{i=0}^n$. Sometimes we also use a shorter notation, just x_i , s_i , or (x_i, s_i) if the exact limits are not of importance. The set of coordinates $(x_i)_{i=0}^n$ constitutes a *mesh* or a *grid*. The individual coordinates x_i are known as *nodes* in the mesh (or grid). The discrete representation of the sine function on $[0, \pi]$ consists of the mesh and the corresponding sequence of function values $(s_i)_{i=0}^n$ at the nodes. The parameter n is often referred to as the *mesh resolution*.

In a program, we represent the mesh by a coordinate array, say \mathbf{x} , and the function values by another array, say \mathbf{s} . To plot the sine function we can simply write

```
from scitools.std import *

n = int(sys.argv[1])

x = linspace(0, pi, n+1)
s = sin(x)
plot(x, s, legend='sin(x), n=%d' % n, hardcopy='tmp.eps')
```

Figure B.1 shows the resulting plot for $n = 5, 10, 20$ and 100. As pointed out in Chapter 5, the curve looks smoother the more points

we use, and since $\sin(x)$ is a smooth function, the plots in Figures B.1a and B.1b do not look sufficiently good. However, we can with our eyes hardly distinguish the plot with 100 points from the one with 20 points, so 20 points seem sufficient in this example.

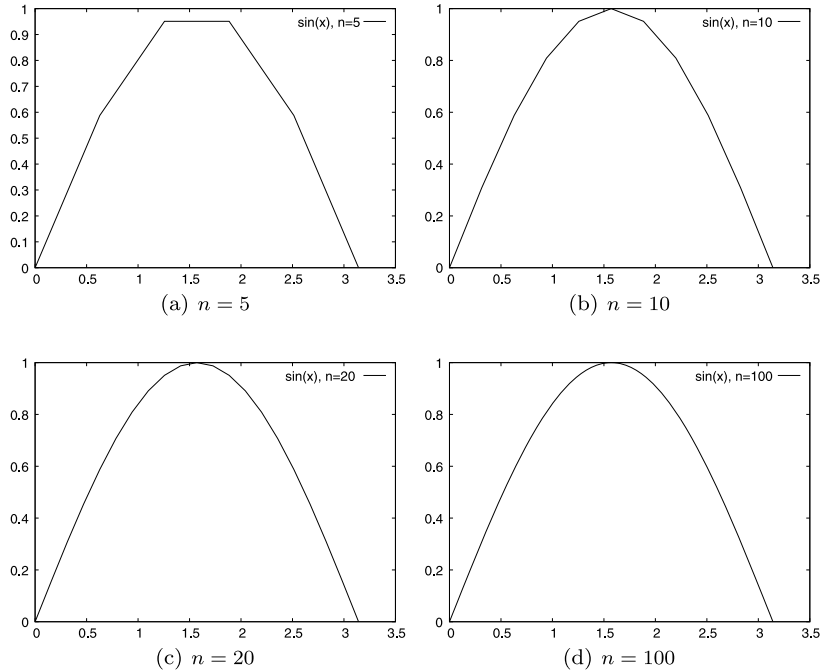

Fig. B.1 Plots of $\sin(x)$ with various n .

There are no tests on the validity of the input data (n) in the previous program. A program including these tests reads³:

```
#!/usr/bin/env python
from scitools.std import *

try:
    n = int(sys.argv[1])
except:
    print "usage: %s n" %sys.argv[0]
    sys.exit(1)

x = linspace(0, pi, n+1)
s = sin(x)
plot(x, s, legend='sin(x), n=%d' % n, hardcopy='tmp.eps')
```

Such tests are important parts of a good programming philosophy. However, for the programs displayed in this and the next chapter, we skip such tests in order to make the programs more compact and readable as part of the rest of the text and to enable focus on the mathematics in the programs. In the versions of these programs in the files

³ For an explanation of the first line of this program, see Appendix H.1.

that can be downloaded you will, hopefully, always find a test on input data.

B.1.2 Interpolation

Suppose we have a discrete representation of the sine function: $(x_i, s_i)_{i=0}^n$. At the nodes we have the exact sine values s_i , but what about the points in between these nodes? Finding function values between the nodes is called *interpolation*, or we can say that we *interpolate* a discrete function.

A graphical interpolation procedure could be to look at one of the plots in Figure B.1 to find the function value corresponding to a point x between the nodes. Since the plot is a straight line from node value to node value, this means that a function value between two nodes is found from a straight line approximation⁴ to the underlying continuous function. We formulate this procedure precisely in terms of mathematics in the next paragraph.

Assume that we know that a given x^* lies in the interval from $x = x_k$ to x_{k+1} , where the integer k is given. In the interval $x_k \leq x < x_{k+1}$, we define the linear function that passes through (x_k, s_k) and (x_{k+1}, s_{k+1}) :

$$S_k(x) = s_k + \frac{s_{k+1} - s_k}{x_{k+1} - x_k}(x - x_k). \quad (\text{B.3})$$

That is, $S_k(x)$ coincides with $\sin(x)$ at x_k and x_{k+1} , and between these nodes, $S_k(x)$ is linear. We say that $S_k(x)$ interpolates the discrete function $(x_i, s_i)_{i=0}^n$ on the interval $[x_k, x_{k+1}]$.

B.1.3 Evaluating the Approximation

Given the values $(x_i, s_i)_{i=0}^n$ and the formula (B.3), we want to compute an approximation of the sine function for any x in the interval from $x = 0$ to $x = \pi$. In order to do that, we have to compute k for a given value of x . More precisely, for a given x we have to find k such that $x_k \leq x \leq x_{k+1}$. We can do that by defining

$$k = \lfloor x/h \rfloor$$

where the function $\lfloor z \rfloor$ denotes the largest integer that is smaller than z . In Python, $\lfloor z \rfloor$ is computed by `int(z)`. The program below takes x and n as input and computes the approximation of $\sin(x)$. The program

⁴ Strictly speaking, we also assume that the function to be interpolated is rather smooth. It is easy to see that if the function is very wild, i.e., the values of the function changes very rapidly, this procedure may fail even for very large values of n . Chapter 5.4.2 provides an example.

prints the approximation $S(x)$ and the exact⁵ value of $\sin(x)$ so we can look at the development of the error when n is increased.

```
from numpy import *
import sys

xp = eval(sys.argv[1])
n = int(sys.argv[2])

def S_k(k):
    return s[k] + \
        ((s[k+1] - s[k])/(x[k+1] - x[k]))*(xp - x[k])

h = pi/n
x = linspace(0, pi, n+1)
s = sin(x)
k = int(xp/h)

print 'Approximation of sin(%s): ' % xp, S_k(k)
print 'Exact value of sin(%s): ' % xp, sin(xp)
print 'Error in approximation: ', sin(xp) - S_k(k)
```

To study the approximation, we put $x = \sqrt{2}$ and use the program `eval_sine.py` for $n = 5, 10$ and 20 .

Terminal

```
eval_sine.py'sqrt(2)' 5
Approximation of sin(1.41421356237): 0.951056516295
Exact value of sin(1.41421356237): 0.987765945993
Error in approximation: 0.0367094296976
```

Terminal

```
eval_sine.py'sqrt(2)' 10
Approximation of sin(1.41421356237): 0.975605666221
Exact value of sin(1.41421356237): 0.987765945993
Error in approximation: 0.0121602797718
```

Terminal

```
eval_sine.py'sqrt(2)' 20
Approximation of sin(1.41421356237): 0.987727284363
Exact value of sin(1.41421356237): 0.987765945993
Error in approximation: 3.86616296923e-05
```

Note that the error is reduced as the n increases.

B.1.4 Generalization

In general, we can create a discrete version of a continuous function as follows. Suppose a continuous function $f(x)$ is defined on an interval

⁵ The value is not really exact – it is the value of $\sin(x)$ provided by the computer, `math.sin(x)`, and this value is calculated from an algorithm that only yields an approximation to $\sin(x)$. Exercise 3.30 provides an example of the type of algorithm in question.

ranging from $x = a$ to $x = b$, and let $n \geq 1$, be a given integer. Define the distance between nodes,

$$h = \frac{b - a}{n},$$

and the nodes

$$x_i = a + ih \text{ for } i = 0, 1, \dots, n. \quad (\text{B.4})$$

The discrete function values are given by

$$y_i = f(x_i) \text{ for } i = 0, 1, \dots, n. \quad (\text{B.5})$$

Now, $(x_i, y_i)_{i=0}^n$ is the discrete version of the continuous function $f(x)$. The program `discrete_func.py` takes f, a, b and n as input, computes the discrete version of f , and then applies the discrete version to make a plot of f .

```
def discrete_func(f, a, b, n):
    x = linspace(a, b, n+1)
    y = zeros(len(x))
    for i in xrange(len(x)):
        y[i] = func(x[i])
    return x, y

from scitools.std import *

f_formula = sys.argv[1]
a = eval(sys.argv[2])
b = eval(sys.argv[3])
n = int(sys.argv[4])
f = StringFunction(f_formula)

x, y = discrete_func(f, a, b, n)
plot(x, y)
```

We can equally well make a vectorized version of the `discrete_func` function:

```
def discrete_func(f, a, b, n):
    x = linspace(a, b, n+1)
    y = f(x)
    return x, y
```

However, for the `StringFunction` tool to work properly in vectorized mode, we need to follow the recipe in Chapter 5.5.1:

```
f = StringFunction(f_formula)
f.vectorize(globals())
```

The corresponding vectorized program is found in the file `discrete_func_vec.py`.

B.2 Differentiation Becomes Finite Differences

You have heard about derivatives. Probably, the following formulas are well known to you:

$$\begin{aligned}\frac{d}{dx} \sin(x) &= \cos(x), \\ \frac{d}{dx} \ln(x) &= \frac{1}{x}, \\ \frac{d}{dx} x^m &= mx^{m-1}.\end{aligned}$$

But why is differentiation so important? The reason is quite simple: The derivative is a mathematical expression of change. And change is, of course, essential in modeling various phenomena. If we know the state of a system, and we know the laws of change, then we can, in principle, compute the future of that system. Appendix C treats this topic in detail. Appendix A also computes the future of systems, based on modeling changes, but without using differentiation. In Appendix C you will see that reducing the step size in the difference equations in Appendix A results in derivatives instead of pure differences. However, differentiation of continuous functions is somewhat hard on a computer, so we often end up replacing the derivatives by differences. This idea is quite general, and every time we use a discrete representation of a function, differentiation becomes differences, or *finite differences* as we usually say.

The mathematical definition of differentiation reads

$$f'(x) = \lim_{\varepsilon \rightarrow 0} \frac{f(x + \varepsilon) - f(x)}{\varepsilon}.$$

You have probably seen this definition many times, but have you understood what it means and do you think the formula has a great practical value? Although the definition requires that we pass to the limit, we obtain quite good approximations of the derivative by using a fixed positive value of ε . More precisely, for a small $\varepsilon > 0$, we have

$$f'(x) \approx \frac{f(x + \varepsilon) - f(x)}{\varepsilon}.$$

The fraction on the right-hand side is a finite difference approximation to the derivative of f at the point x . Instead of using ε it is more common to introduce $h = \varepsilon$ in finite differences, i.e., we like to write

$$f'(x) \approx \frac{f(x + h) - f(x)}{h}. \quad (\text{B.6})$$

B.2.1 Differentiating the Sine Function

In order to get a feeling for how good the approximation (B.6) to the derivative really is, we explore an example. Consider $f(x) = \sin(x)$ and the associated derivative $f'(x) = \cos(x)$. If we put $x = 1$, we have

$$f'(1) = \cos(1) \approx 0.540,$$

and by putting $h = 1/100$ in (B.6) we get

$$f'(1) \approx \frac{f(1 + 1/100) - f(1)}{1/100} = \frac{\sin(1.01) - \sin(1)}{0.01} \approx 0.536.$$

The program `forward_diff.py`, shown below, computes the derivative of $f(x)$ using the approximation (B.6), where x and h are input parameters.

```
def diff(f, x, h):
    return (f(x+h) - f(x))/float(h)

from math import *
import sys

x = eval(sys.argv[1])
h = eval(sys.argv[2])

approx_deriv = diff(sin, x, h)
exact = cos(x)
print 'The approximated value is: ', approx_deriv
print 'The correct value is:      ', exact
print 'The error is:              ', exact - approx_deriv
```

Running the program for $x = 1$ and $h = 1/1000$ gives

Terminal

```
forward_diff.py 1 0.001
The approximated value is: 0.53988148036
The correct value is:     0.540302305868
The error is:             0.000420825507813
```

B.2.2 Differences on a Mesh

Frequently, we will need finite difference approximations to a discrete function defined on a mesh. Suppose we have a discrete representation of the sine function: $(x_i, s_i)_{i=0}^n$, as introduced in Chapter B.1.1. We want to use (B.6) to compute approximations to the derivative of the sine function at the nodes in the mesh. Since we only have function values at the nodes, the h in (B.6) must be the difference between nodes, i.e., $h = x_{i+1} - x_i$. At node x_i we then have the following approximation of the derivative:

$$z_i = \frac{s_{i+1} - s_i}{h}, \tag{B.7}$$

for $i = 0, 1, \dots, n - 1$. Note that we have not defined an approximate derivative at the end point $x = x_n$. We cannot apply (B.7) directly since s_{n+1} is undefined (outside the mesh). However, the derivative of a function can also be defined as

$$f'(x) = \lim_{\varepsilon \rightarrow 0} \frac{f(x) - f(x - \varepsilon)}{\varepsilon},$$

which motivates the following approximation for a given $h > 0$,

$$f'(x) \approx \frac{f(x) - f(x - h)}{h}. \quad (\text{B.8})$$

This alternative approximation to the derivative is referred to as a *backward difference* formula, whereas the expression (B.6) is known as a *forward difference* formula. The names are natural: The forward formula goes forward, i.e., in the direction of increasing x and i to collect information about the change of the function, while the backward formula goes backwards, i.e., toward smaller x and i value to fetch function information.

At the end point we can apply the backward formula and thus define

$$z_n = \frac{s_n - s_{n-1}}{h}. \quad (\text{B.9})$$

We now have an approximation to the derivative at all the nodes. A plain specialized program for computing the derivative of the sine function on a mesh and comparing this discrete derivative with the exact derivative is displayed below (the name of the file is `diff_sine_plot1.py`).

```
from scitools.std import *

n = int(sys.argv[1])

h = pi/n
x = linspace(0, pi, n+1)
s = sin(x)
z = zeros(len(s))
for i in xrange(len(z)-1):
    z[i] = (s[i+1] - s[i])/h
# Special formula for end point_
z[-1] = (s[-1] - s[-2])/h
plot(x, z)

xfine = linspace(0, pi, 1001) # for more accurate plot
exact = cos(xfine)
hold()
plot(xfine, exact)
legend('Approximate function', 'Correct function')
title('Approximate and discrete functions, n=%d' % n)
```

In Figure B.2 we see the resulting graphs for $n = 5, 10, 20$ and 100 . Again, we note that the error is reduced as n increases.

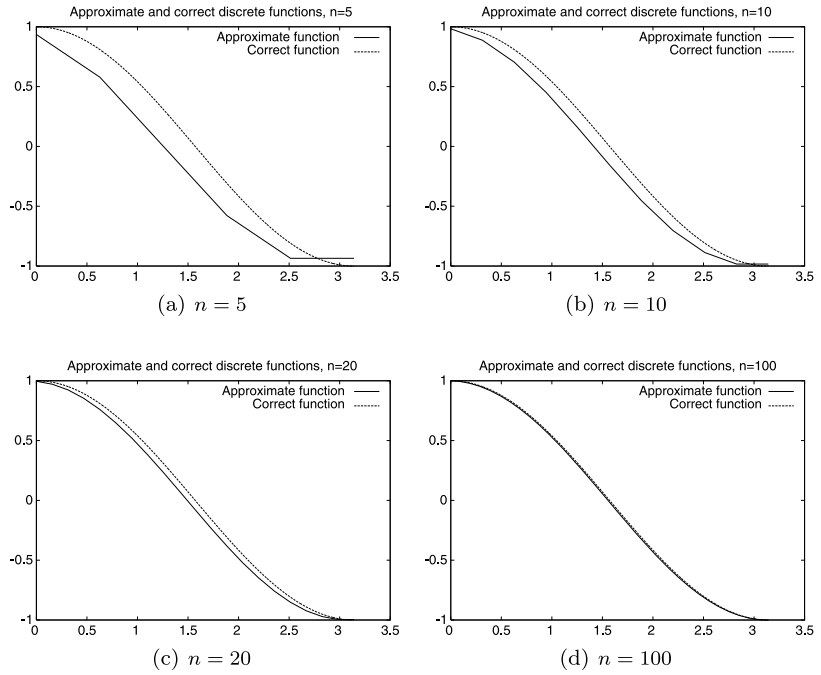

Fig. B.2 Plots for exact and approximate derivatives of $\sin(x)$ with varying values of the resolution n .

B.2.3 Generalization

The discrete version of a continuous function $f(x)$ defined on an interval $[a, b]$ is given by $(x_i, y_i)_{i=0}^n$ where

$$x_i = a + ih,$$

and

$$y_i = f(x_i)$$

for $i = 0, 1, \dots, n$. Here, $n \geq 1$ is a given integer, and the spacing between the nodes is given by

$$h = \frac{b - a}{n}.$$

A discrete approximation of the derivative of f is given by $(x_i, z_i)_{i=0}^n$ where

$$z_i = \frac{y_{i+1} - y_i}{h}$$

$i = 0, 1, \dots, n - 1$, and

$$z_n = \frac{y_n - y_{n-1}}{h}.$$

The collection $(x_i, z_i)_{i=0}^n$ is the discrete derivative of the discrete version $(x_i, f_i)_{i=0}^n$ of the continuous function $f(x)$. The program below, found in the file `diff_func.py`, takes f, a, b and n as input and computes the discrete derivative of f on the mesh implied by a, b , and h , and then a plot of f and the discrete derivative is made.

```
def diff(f, a, b, n):
    x = linspace(a, b, n+1)
    y = zeros(len(x))
    z = zeros(len(x))
    h = (b-a)/float(n)
    for i in xrange(len(x)):
        y[i] = func(x[i])
    for i in xrange(len(x)-1):
        z[i] = (y[i+1] - y[i])/h
    z[n] = (y[n] - y[n-1])/h
    return y, z

from scitools.std import *
f_formula = sys.argv[1]
a = eval(sys.argv[2])
b = eval(sys.argv[3])
n = int(sys.argv[4])

f = StringFunction(f_formula)
y, z = diff(f, a, b, n)
plot(x, y, 'r-', x, z, 'b-',
      legend=('function', 'derivative'))
```

B.3 Integration Becomes Summation

Some functions can be integrated analytically. You may remember⁶ the following cases,

$$\int x^m dx = \frac{1}{m+1} x^{m+1} \text{ for } m \neq -1,$$

$$\int \sin(x) dx = -\cos(x),$$

$$\int \frac{x}{1+x^2} dx = \frac{1}{2} \ln(x^2 + 1).$$

These are examples of so-called indefinite integrals. If the function can be integrated analytically, it is straightforward to evaluate an associated definite integral. For example, we have⁷

⁶ Actually, we congratulate you if you remember the third one!

⁷ Recall, in general, that

$$[f(x)]_a^b = f(b) - f(a).$$

$$\int_0^1 x^m dx = \left[\frac{1}{m+1} x^{m+1} \right]_0^1 = \frac{1}{m+1},$$

$$\int_0^\pi \sin(x) dx = [-\cos(x)]_0^\pi = 2,$$

$$\int_0^1 \frac{x}{1+x^2} dx = \left[\frac{1}{2} \ln(x^2+1) \right]_0^1 = \frac{1}{2} \ln 2.$$

But lots of functions cannot be integrated analytically and therefore definite integrals must be computed using some sort of numerical approximation. Above, we introduced the discrete version of a function, and we will now use this construction to compute an approximation of a definite integral.

B.3.1 Dividing into Subintervals

Let us start by considering the problem of computing the integral of $\sin(x)$ from $x = 0$ to $x = \pi$. This is not the most exciting or challenging mathematical problem you can think of, but it is good practice to start with a problem you know well when you want to learn a new method. In Chapter B.1.1 we introduce a discrete function $(x_i, s_i)_{i=0}^n$ where $h = \pi/n$, $s_i = \sin(x_i)$ and $x_i = ih$ for $i = 0, 1, \dots, n$. Furthermore, in the interval $x_k \leq x < x_{k+1}$, we defined the linear function

$$S_k(x) = s_k + \frac{s_{k+1} - s_k}{x_{k+1} - x_k}(x - x_k).$$

We want to compute an approximation of the integral of the function $\sin(x)$ from $x = 0$ to $x = \pi$. The integral

$$\int_0^\pi \sin(x) dx$$

can be divided into subintegrals defined on the intervals $x_k \leq x < x_{k+1}$, leading to the following sum of integrals:

$$\int_0^\pi \sin(x) dx = \sum_{k=0}^{n-1} \int_{x_k}^{x_{k+1}} \sin(x) dx.$$

To get a feeling for this split of the integral, let us spell the sum out in the case of only four subintervals. Then $n = 4$, $h = \pi/4$,

$$x_0 = 0,$$

$$x_1 = \pi/4,$$

$$x_2 = \pi/2,$$

$$x_3 = 3\pi/4$$

$$x_4 = \pi.$$

The interval from 0 to π is divided into four intervals of equal length, and we can divide the integral similarly,

$$\begin{aligned} \int_0^\pi \sin(x)dx &= \int_{x_0}^{x_1} \sin(x)dx + \int_{x_1}^{x_2} \sin(x)dx \\ &+ \int_{x_2}^{x_3} \sin(x)dx + \int_{x_3}^{x_4} \sin(x)dx. \end{aligned} \quad (\text{B.10})$$

So far we have changed nothing – the integral can be split in this way – with no approximation at all. But we have reduced the problem of approximating the integral

$$\int_0^\pi \sin(x)dx$$

down to approximating integrals on the subintervals, i.e. we need approximations of all the following integrals

$$\int_{x_0}^{x_1} \sin(x)dx, \int_{x_1}^{x_2} \sin(x)dx, \int_{x_2}^{x_3} \sin(x)dx, \int_{x_3}^{x_4} \sin(x)dx.$$

The idea is that the function to be integrated changes less over the subintervals than over the whole domain $[0, \pi]$ and it might be reasonable to approximate the sine by a straight line, $S_k(x)$, over each subinterval. The integration over a subinterval will then be very easy.

B.3.2 Integration on Subintervals

The task now is to approximate integrals on the form

$$\int_{x_k}^{x_{k+1}} \sin(x)dx.$$

Since

$$\sin(x) \approx S_k(x)$$

on the interval (x_k, x_{k+1}) , we have

$$\int_{x_k}^{x_{k+1}} \sin(x)dx \approx \int_{x_k}^{x_{k+1}} S_k(x)dx.$$

In Figure B.3 we have graphed $S_k(x)$ and $\sin(x)$ on the interval (x_k, x_{k+1}) for $k = 1$ in the case of $n = 4$. We note that the integral of $S_1(x)$ on this interval equals the area of a trapezoid, and thus we have

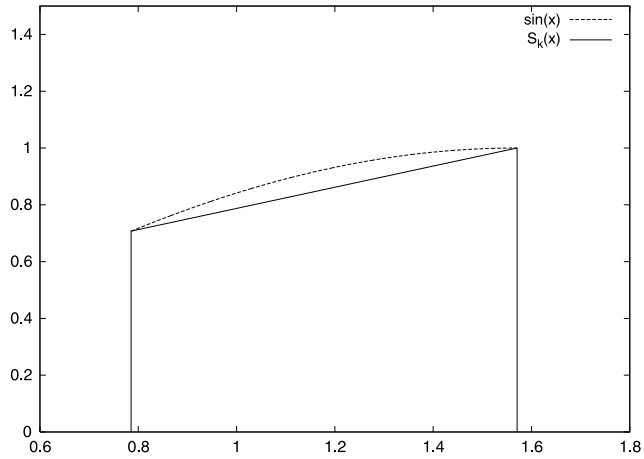

Fig. B.3 $S_k(x)$ and $\sin(x)$ on the interval (x_k, x_{k+1}) for $k = 1$ and $n = 4$.

$$\int_{x_1}^{x_2} S_1(x) dx = \frac{1}{2}(S_1(x_2) + S_1(x_1))(x_2 - x_1),$$

so

$$\int_{x_1}^{x_2} S_1(x) dx = \frac{h}{2}(s_2 + s_1),$$

and in general we have

$$\begin{aligned} \int_{x_k}^{x_{k+1}} \sin(x) dx &\approx \frac{1}{2}(s_{k+1} + s_k)(x_{k+1} - x_k) \\ &= \frac{h}{2}(s_{k+1} + s_k). \end{aligned}$$

B.3.3 Adding the Subintervals

By adding the contributions from each subinterval, we get

$$\begin{aligned} \int_0^\pi \sin(x) dx &= \sum_{k=0}^{n-1} \int_{x_k}^{x_{k+1}} \sin(x) dx \\ &\approx \sum_{k=0}^{n-1} \frac{h}{2}(s_{k+1} + s_k), \end{aligned}$$

so

$$\int_0^\pi \sin(x) dx \approx \frac{h}{2} \sum_{k=0}^{n-1} (s_{k+1} + s_k). \quad (\text{B.11})$$

In the case of $n = 4$, we have

$$\begin{aligned}\int_0^\pi \sin(x)dx &\approx \frac{h}{2} [(s_1 + s_0) + (s_2 + s_1) + (s_3 + s_2) + (s_4 + s_3)] \\ &= \frac{h}{2} [s_0 + 2(s_1 + s_2 + s_3) + s_4].\end{aligned}$$

One can show that (B.11) can be alternatively expressed as⁸

$$\int_0^\pi \sin(x)dx \approx \frac{h}{2} \left[s_0 + 2 \sum_{k=1}^{n-1} s_k + s_n \right]. \quad (\text{B.12})$$

This approximation formula is referred to as the Trapezoidal rule of numerical integration. Using the more general program `trapezoidal.py`, presented in the next section, on integrating $\int_0^\pi \sin(x)dx$ with $n = 5, 10, 20$ and 100 yields the numbers $1.5644, 1.8864, 1.9713,$ and 1.9998 respectively. These numbers are to be compared to the exact value 2 . As usual, the approximation becomes better the more points (n) we use.

B.3.4 Generalization

An approximation of the integral

$$\int_a^b f(x)dx$$

can be computed using the discrete version of a continuous function $f(x)$ defined on an interval $[a, b]$. We recall that the discrete version of f is given by $(x_i, y_i)_{i=0}^n$ where

$$x_i = a + ih, \text{ and } y_i = f(x_i)$$

for $i = 0, 1, \dots, n$. Here, $n \geq 1$ is a given integer and $h = (b - a)/n$. The Trapezoidal rule can now be written as

$$\int_a^b f(x)dx \approx \frac{h}{2} \left[y_0 + 2 \sum_{k=1}^{n-1} y_k + y_n \right].$$

The program `trapezoidal.py` implements the Trapezoidal rule for a general function f .

```
def trapezoidal(f, a, b, n):
    h = (b-a)/float(n)
    I = f(a) + f(b)
    for k in xrange(1, n, 1):
        x = a + k*h
        I += 2*f(x)
```

⁸ There are fewer arithmetic operations associated with (B.12) than with (B.11), so the former will lead to faster code.

```

I *= h/2
return I

from math import *
from scitools.StringFunction import StringFunction
import sys

def test(argv=sys.argv):
    f_formula = argv[1]
    a = eval(argv[2])
    b = eval(argv[3])
    n = int(argv[4])

    f = StringFunction(f_formula)
    I = trapezoidal(f, a, b, n)
    print 'Approximation of the integral: ', I

if __name__ == '__main__':
    test()

```

We have made the file as module such that you can easily import the trapezoidal function in another program. Let us do that: We make a table of how the approximation and the associated error of an integral are reduced as n is increased. For this purpose, we want to integrate $\int_{t_1}^{t_2} g(t)dt$, where

$$g(t) = -ae^{-at} \sin(\pi wt) + \pi we^{-at} \cos(\pi wt).$$

The exact integral $G(t) = \int g(t)dt$ equals

$$G(t) = e^{-at} \sin(\pi wt).$$

Here, a and w are real numbers that we set to $1/2$ and 1 , respectively, in the program. The integration limits are chosen as $t_1 = 0$ and $t_2 = 4$. The integral then equals zero. The program and its output appear below.

```

from trapezoidal import trapezoidal
from math import exp, sin, cos, pi

def g(t):
    return -a*exp(-a*t)*sin(pi*w*t) + pi*w*exp(-a*t)*cos(pi*w*t)

def G(t): # integral of g(t)
    return exp(-a*t)*sin(pi*w*t)

a = 0.5
w = 1.0
t1 = 0
t2 = 4
exact = G(t2) - G(t1)
for n in 2, 4, 8, 16, 32, 64, 128, 256, 512:
    approx = trapezoidal(g, t1, t2, n)
    print 'n=%3d approximation=%12.5e error=%12.5e' % \
        (n, approx, exact-approx)

```

```

n= 2 approximation= 5.87822e+00 error=-5.87822e+00
n= 4 approximation= 3.32652e-01 error=-3.32652e-01
n= 8 approximation= 6.15345e-02 error=-6.15345e-02

```

```

n= 16 approximation= 1.44376e-02 error=-1.44376e-02
n= 32 approximation= 3.55482e-03 error=-3.55482e-03
n= 64 approximation= 8.85362e-04 error=-8.85362e-04
n=128 approximation= 2.21132e-04 error=-2.21132e-04
n=256 approximation= 5.52701e-05 error=-5.52701e-05
n=512 approximation= 1.38167e-05 error=-1.38167e-05

```

We see that the error is reduced as we increase n . In fact, as n is doubled we realize that the error is roughly reduced by a factor of 4, at least when $n > 8$. This is an important property of the Trapezoidal rule, and checking that a program reproduces this property is an important check of the validity of the implementation.

B.4 Taylor Series

The single most important mathematical tool in computational science is the Taylor series. It is used to derive new methods and also for the analysis of the accuracy of approximations. We will use the series many times in this text. Right here, we just introduce it and present a few applications.

B.4.1 Approximating Functions Close to One Point

Suppose you know the value of a function f at some point x_0 , and you are interested in the value of f close to x . More precisely, suppose we know $f(x_0)$ and we want an approximation of $f(x_0 + h)$ where h is a small number. If the function is smooth and h is really small, our first approximation reads

$$f(x_0 + h) \approx f(x_0). \quad (\text{B.13})$$

That approximation is, of course, not very accurate. In order to derive a more accurate approximation, we have to know more about f at x_0 . Suppose that we know the value of $f(x_0)$ and $f'(x_0)$, then we can find a better approximation of $f(x_0 + h)$ by recalling that

$$f'(x_0) \approx \frac{f(x_0 + h) - f(x_0)}{h}.$$

Hence, we have

$$f(x_0 + h) \approx f(x_0) + hf'(x_0). \quad (\text{B.14})$$

B.4.2 Approximating the Exponential Function

Let us be a bit more specific and consider the case of

$$f(x) = e^x$$

around

$$x_0 = 0.$$

Since $f'(x) = e^x$, we have $f'(0) = 1$, and then it follows from (B.14) that

$$e^h \approx 1 + h.$$

The little program below (found in `taylor1.py`) prints e^h and $1 + h$ for a range of h values.

```
from math import exp
for h in 1, 0.5, 1/20.0, 1/100.0, 1/1000.0:
    print 'h=%8.6f exp(h)=%11.5e 1+h=%g' % (h, exp(h), 1+h)
```

```
h=1.000000 exp(h)=2.71828e+00 1+h=2
h=0.500000 exp(h)=1.64872e+00 1+h=1.5
h=0.050000 exp(h)=1.05127e+00 1+h=1.05
h=0.010000 exp(h)=1.01005e+00 1+h=1.01
h=0.001000 exp(h)=1.00100e+00 1+h=1.001
```

As expected, $1 + h$ is a good approximation to e^h the smaller h is.

B.4.3 More Accurate Expansions

The approximations given by (B.13) and (B.14) are referred to as Taylor series. You can read much more about Taylor series in any Calculus book. More specifically, (B.13) and (B.14) are known as the zeroth- and first-order Taylor series, respectively. The second-order Taylor series is given by

$$f(x_0 + h) \approx f(x_0) + hf'(x_0) + \frac{h^2}{2}f''(x_0), \quad (\text{B.15})$$

the third-order series is given by

$$f(x_0 + h) \approx f(x_0) + hf'(x_0) + \frac{h^2}{2}f''(x_0) + \frac{h^3}{6}f'''(x_0), \quad (\text{B.16})$$

and the fourth-order series reads

$$f(x_0 + h) \approx f(x_0) + hf'(x_0) + \frac{h^2}{2}f''(x_0) + \frac{h^3}{6}f'''(x_0) + \frac{h^4}{24}f^{(4)}(x_0). \quad (\text{B.17})$$

In general, the n -th order Taylor series is given by

$$f(x_0 + h) \approx \sum_{k=0}^n \frac{h^k}{k!} f^{(k)}(x_0), \quad (\text{B.18})$$

where we recall that $f^{(k)}$ denotes the k -th derivative of f , and

$$k! = 1 \cdot 2 \cdot 3 \cdot 4 \cdots (k-1) \cdot k$$

is the factorial (cf. Exercise 3.19). By again considering $f(x) = e^x$ and $x_0 = 0$, we have

$$f(x_0) = f'(x_0) = f''(x_0) = f'''(x_0) = f^{(4)}(x_0) = 1$$

which gives the following Taylor series:

$$\begin{aligned}
 e^h &\approx 1, && \text{zeroth-order,} \\
 e^h &\approx 1 + h, && \text{first-order,} \\
 e^h &\approx 1 + h + \frac{1}{2}h^2, && \text{second-order,} \\
 e^h &\approx 1 + h + \frac{1}{2}h^2 + \frac{1}{6}h^3, && \text{third-order,} \\
 e^h &\approx 1 + h + \frac{1}{2}h^2 + \frac{1}{6}h^3 + \frac{1}{24}h^4, && \text{fourth-order.}
 \end{aligned}$$

The program below, called `taylor2.py`, prints the error of these approximations for a given value of h (note that we can easily build up a Taylor series in a list by adding a new term to the last computed term in the list).

```

from math import exp
import sys
h = float(sys.argv[1])

Taylor_series = []
Taylor_series.append(1)
Taylor_series.append(Taylor_series[-1] + h)
Taylor_series.append(Taylor_series[-1] + (1/2.0)*h**2)
Taylor_series.append(Taylor_series[-1] + (1/6.0)*h**3)
Taylor_series.append(Taylor_series[-1] + (1/24.0)*h**4)

print'h =', h
for order in range(len(Taylor_series)):
    print'order=%d, error=%g' % \
        (order, exp(h) - Taylor_series[order])

```

By running the program with $h = 0.2$, we have the following output:

```

h = 0.2
order=0, error=0.221403
order=1, error=0.0214028
order=2, error=0.00140276
order=3, error=6.94248e-05
order=4, error=2.75816e-06

```

We see how much the approximation is improved by adding more terms. For $h = 3$ all these approximations are useless:

```

h = 3.0
order=0, error=19.0855
order=1, error=16.0855
order=2, error=11.5855
order=3, error=7.08554
order=4, error=3.71054

```

However, by adding more terms we can get accurate results for any h . The method from Appendix [A.1.8](#) computes the Taylor series for e^x with n terms in general. Running the associated program `exp_Taylor_series_diffeq.py` for various values of h shows how much is gained by adding more terms to the Taylor series. For $h = 3$, $e^3 = 20.086$ and we have

$n + 1$	Taylor series
2	4
4	13
8	19.846
16	20.086

For $h = 50$, $e^{50} = 5.1847 \cdot 10^{21}$ and we have

$n + 1$	Taylor series
2	51
4	$2.2134 \cdot 10^4$
8	$1.7960 \cdot 10^8$
16	$3.2964 \cdot 10^{13}$
32	$1.3928 \cdot 10^{19}$
64	$5.0196 \cdot 10^{21}$
128	$5.1847 \cdot 10^{21}$

Here, the evolution of the series as more terms are added is quite dramatic (and impressive!).

B.4.4 Accuracy of the Approximation

Recall that the Taylor series is given by

$$f(x_0 + h) \approx \sum_{k=0}^n \frac{h^k}{k!} f^{(k)}(x_0). \quad (\text{B.19})$$

This can be rewritten as an equality by introducing an error term,

$$f(x_0 + h) = \sum_{k=0}^n \frac{h^k}{k!} f^{(k)}(x_0) + O(h^{n+1}). \quad (\text{B.20})$$

Let's look a bit closer at this for $f(x) = e^x$. In the case of $n = 1$, we have

$$e^h = 1 + h + O(h^2). \quad (\text{B.21})$$

This means that there is a constant c that does not depend on h such that

$$|e^h - (1 + h)| \leq ch^2, \quad (\text{B.22})$$

so the error is reduced quadratically in h . This means that if we compute the fraction

$$q_h^1 = \frac{|e^h - (1 + h)|}{h^2},$$

we expect it to be bounded as h is reduced. The program `taylor_err1.py` prints q_h^1 for $h = 1/10, 1/20, 1/100$ and $1/1000$.

```

from numpy import exp, abs

def q_h(h):
    return abs(exp(h) - (1+h))/h**2

print " h      q_h"
for h in 0.1, 0.05, 0.01, 0.001:
    print "%5.3f %f" %(h, q_h(h))

```

We can run the program and watch the output:

Terminal

```

taylor_err1.py
h      q_h
0.100 0.517092
0.050 0.508439
0.010 0.501671
0.001 0.500167

```

We observe that $q_h \approx 1/2$ and it is definitely bounded independent of h . We can now rewrite all the approximations of e^h defined above in term of equalities:

$$\begin{aligned}
 e^h &= 1 + O(h), && \text{zeroth-order,} \\
 e^h &= 1 + h + O(h^2), && \text{first-order,} \\
 e^h &= 1 + h + \frac{1}{2}h^2 + O(h^3), && \text{second-order,} \\
 e^h &= 1 + h + \frac{1}{2}h^2 + \frac{1}{6}h^3 + O(h^4), && \text{third-order,} \\
 e^h &= 1 + h + \frac{1}{2}h^2 + \frac{1}{6}h^3 + \frac{1}{24}h^4 + O(h^5), && \text{fourth-order.}
 \end{aligned}$$

The program `taylor_err2.py` prints

$$\begin{aligned}
 q_h^0 &= \frac{|e^h - 1|}{h}, \\
 q_h^1 &= \frac{|e^h - (1 + h)|}{h^2}, \\
 q_h^2 &= \frac{|e^h - (1 + h + \frac{h^2}{2})|}{h^3}, \\
 q_h^3 &= \frac{|e^h - (1 + h + \frac{h^2}{2} + \frac{h^3}{6})|}{h^4}, \\
 q_h^4 &= \frac{|e^h - (1 + h + \frac{h^2}{2} + \frac{h^3}{6} + \frac{h^4}{24})|}{h^5},
 \end{aligned}$$

for $h = 1/5, 1/10, 1/20$ and $1/100$.

```

from numpy import exp, abs

def q_0(h):
    return abs(exp(h) - 1) / h
def q_1(h):

```

```

    return abs(exp(h) - (1 + h)) / h**2
def q_2(h):
    return abs(exp(h) - (1 + h + (1/2.0)*h**2)) / h**3
def q_3(h):
    return abs(exp(h) - (1 + h + (1/2.0)*h**2 + \
        (1/6.0)*h**3)) / h**4
def q_4(h):
    return abs(exp(h) - (1 + h + (1/2.0)*h**2 + (1/6.0)*h**3 + \
        (1/24.0)*h**4)) / h**5
hlist = [0.2, 0.1, 0.05, 0.01]
print "%-05s %-09s %-09s %-09s %-09s %-09s" \
    %("h", "q_0", "q_1", "q_2", "q_3", "q_4")
for h in hlist:
    print "%.02f %04f %04f %04f %04f %04f" \
        %(h, q_0(h), q_1(h), q_2(h), q_3(h), q_4(h))

```

By using the program, we get the following table:

h	q_0	q_1	q_2	q_3	q_4
0.20	1.107014	0.535069	0.175345	0.043391	0.008619
0.10	1.051709	0.517092	0.170918	0.042514	0.008474
0.05	1.025422	0.508439	0.168771	0.042087	0.008403
0.01	1.005017	0.501671	0.167084	0.041750	0.008344

Again we observe that the error of the approximation behaves as indicated in (B.20).

B.4.5 Derivatives Revisited

We observed above that

$$f'(x) \approx \frac{f(x+h) - f(x)}{h}.$$

By using the Taylor series, we can obtain this approximation directly, and also get an indication of the error of the approximation. From (B.20) it follows that

$$f(x+h) = f(x) + hf'(x) + O(h^2),$$

and thus

$$f'(x) = \frac{f(x+h) - f(x)}{h} + O(h), \quad (\text{B.23})$$

so the error is proportional to h . We can investigate if this is the case through some computer experiments. Take $f(x) = \ln(x)$, so that $f'(x) = 1/x$. The program `diff_ln_err.py` prints h and

$$\frac{1}{h} \left| f'(x) - \frac{f(x+h) - f(x)}{h} \right| \quad (\text{B.24})$$

at $x = 10$ for a range of h values.

```

def error(h):
    return (1.0/h)*abs(df(x) - (f(x+h)-f(x))/h)

from math import log as ln

```



```

def f(x):
    return ln(x)

def df(x):
    return 1.0/x

x = 10
hlist = []
for h in 0.2, 0.1, 0.05, 0.01, 0.001:
    print "%.4f    %4f" % (h, error(h))

```

From the output

```

0.2000    0.004934
0.1000    0.004967
0.0500    0.004983
0.0100    0.004997
0.0010    0.005000

```

we observe that the quantity in (B.24) is constant (≈ 0.5) independent of h , which indicates that the error is proportional to h .

B.4.6 More Accurate Difference Approximations

We can also use the Taylor series to derive more accurate approximations of the derivatives. From (B.20), we have

$$f(x+h) \approx f(x) + hf'(x) + \frac{h^2}{2}f''(x) + O(h^3). \quad (\text{B.25})$$

By using $-h$ instead of h , we get

$$f(x-h) \approx f(x) - hf'(x) + \frac{h^2}{2}f''(x) + O(h^3). \quad (\text{B.26})$$

By subtracting (B.26) from (B.25), we have

$$f(x+h) - f(x-h) = 2hf'(x) + O(h^3),$$

and consequently

$$f'(x) = \frac{f(x+h) - f(x-h)}{2h} + O(h^2). \quad (\text{B.27})$$

Note that the error is now $O(h^2)$ whereas the error term of (B.23) is $O(h)$. In order to see if the error is actually reduced, let us compare the following two approximations

$$f'(x) \approx \frac{f(x+h) - f(x)}{h} \quad \text{and} \quad f'(x) \approx \frac{f(x+h) - f(x-h)}{2h}$$

by applying them to the discrete version of $\sin(x)$ on the interval $(0, \pi)$. As usual, we let $n \geq 1$ be a given integer, and define the mesh

$$x_i = ih \quad \text{for } i = 0, 1, \dots, n,$$

where $h = \pi/n$. At the nodes, we have the functional values

$$s_i = \sin(x_i) \text{ for } i = 0, 1, \dots, n,$$

and at the inner nodes we define the first (F) and second (S) order approximations of the derivatives given by

$$d_i^F = \frac{s_{i+1} - s_i}{h},$$

and

$$d_i^S = \frac{s_{i+1} - s_{i-1}}{2h},$$

respectively for $i = 1, 2, \dots, n-1$. These values should be compared to the exact derivative given by

$$d_i = \cos(x_i) \text{ for } i = 1, 2, \dots, n-1.$$

The following program, found in `diff_1st2nd_order.py`, plots the discrete functions $(x_i, d_i)_{i=1}^{n-1}$, $(x_i, d_i^F)_{i=1}^{n-1}$, and $(x_i, d_i^S)_{i=1}^{n-1}$ for a given n . Note that the first three functions in this program are completely general in that they can be used for any $f(x)$ on any mesh. The special case of $f(x) = \sin(x)$ and comparing first- and second-order formulas is implemented in the `example` function. This latter function is called in the test block of the file. That is, the file is a module and we can reuse the first three functions in other programs (in particular, we can use the third function in the next example).

```
def first_order(f, x, h):
    return (f(x+h) - f(x))/h

def second_order(f, x, h):
    return (f(x+h) - f(x-h))/(2*h)

def derivative_on_mesh(formula, f, a, b, n):
    """
    Differentiate f(x) at all internal points in a mesh
    on [a,b] with n+1 equally spaced points.
    The differentiation formula is given by formula(f, x, h).
    """
    h = (b-a)/float(n)
    x = linspace(a, b, n+1)
    df = zeros(len(x))
    for i in xrange(1, len(x)-1):
        df[i] = formula(f, x[i], h)
    # Return x and values at internal points only
    return x[1:-1], df[1:-1]

def example(n):
    a = 0; b = pi;
    x, dF = derivative_on_mesh(first_order, sin, a, b, n)
    x, dS = derivative_on_mesh(second_order, sin, a, b, n)
    # Accurate plot of the exact derivative at internal points
    h = (b-a)/float(n)
    xfine = linspace(a+h, b-h, 1001)
    exact = cos(xfine)
    plot(x, dF, 'r-', x, dS, 'b-', xfine, exact, 'y-',
```

```

legend=('First-order derivative',
        'Second-order derivative',
        'Correct function'),
title='Approximate and correct discrete '\
      'functions, n=%d' % n)

# Main program
from scitools.std import *
try:
    n = int(sys.argv[1])
except:
    print "usage: %s n" %sys.argv[0]
    sys.exit(1)

example(n)

```

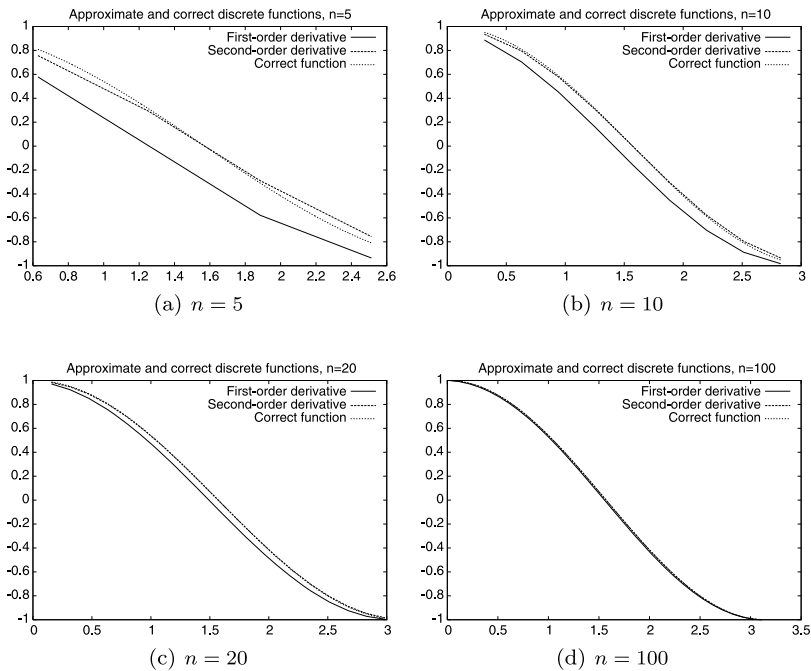

Fig. B.4 Plots of exact and approximate derivatives with various number of mesh points n .

The result of running the program with four different n values is presented in Figure B.4. Observe that d_i^S is a better approximation to d_i than d_i^F , and note that both approximations become very good as n is getting large.

B.4.7 Second-Order Derivatives

We have seen that the Taylor series can be used to derive approximations of the derivative. But what about higher order derivatives? Next we shall look at second order derivatives. From (B.20) we have

$$f(x_0 + h) = f(x_0) + hf'(x_0) + \frac{h^2}{2}f''(x_0) + \frac{h^3}{6}f'''(x_0) + O(h^4),$$

and by using $-h$, we have

$$f(x_0 - h) = f(x_0) - hf'(x_0) + \frac{h^2}{2}f''(x_0) - \frac{h^3}{6}f'''(x_0) + O(h^4).$$

By adding these equations, we have

$$f(x_0 + h) + f(x_0 - h) = 2f(x_0) + h^2f''(x_0) + O(h^4),$$

and thus

$$f''(x_0) = \frac{f(x_0 - h) - 2f(x_0) + f(x_0 + h)}{h^2} + O(h^2). \quad (\text{B.28})$$

For a discrete function $(x_i, y_i)_{i=0}^n$, $y_i = f(x_i)$, we can define the following approximation of the second derivative,

$$d_i = \frac{y_{i-1} - 2y_i + y_{i+1}}{h^2}. \quad (\text{B.29})$$

We can make a function, found in the file `diff2nd.py`, that evaluates (B.29) on a mesh. As an example, we apply the function to

$$f(x) = \sin(e^x),$$

where the exact second-order derivative is given by

$$f''(x) = e^x \cos(e^x) - (\sin(e^x))e^{2x}.$$

```

from diff_1st2nd_order import derivative_on_mesh
from scitools.std import *

def diff2nd(f, x, h):
    return (f(x+h) - 2*f(x) + f(x-h))/(h**2)

def example(n):
    a = 0; b = pi

    def f(x):
        return sin(exp(x))

    def exact_d2f(x):
        e_x = exp(x)
        return e_x*cos(e_x) - sin(e_x)*exp(2*x)

    x, d2f = derivative_on_mesh(diff2nd, f, a, b, n)
    h = (b-a)/float(n)
    xfine = linspace(a+h, b-h, 1001) # fine mesh for comparison
    exact = exact_d2f(xfine)
    plot(x, d2f, 'r-', xfine, exact, 'b-',
         legend=('Approximate derivative',
                'Correct function'),
         title='Approximate and correct second order \
                derivatives, n=%d' % n,
         hardcopy='tmp.eps')

n = int(sys.argv[1])

example(n)

```

In Figure B.5 we compare the exact and the approximate derivatives for $n = 10, 20, 50,$ and 100 . As usual, the error decreases when n becomes larger, but note here that the error is very large for small values of n .

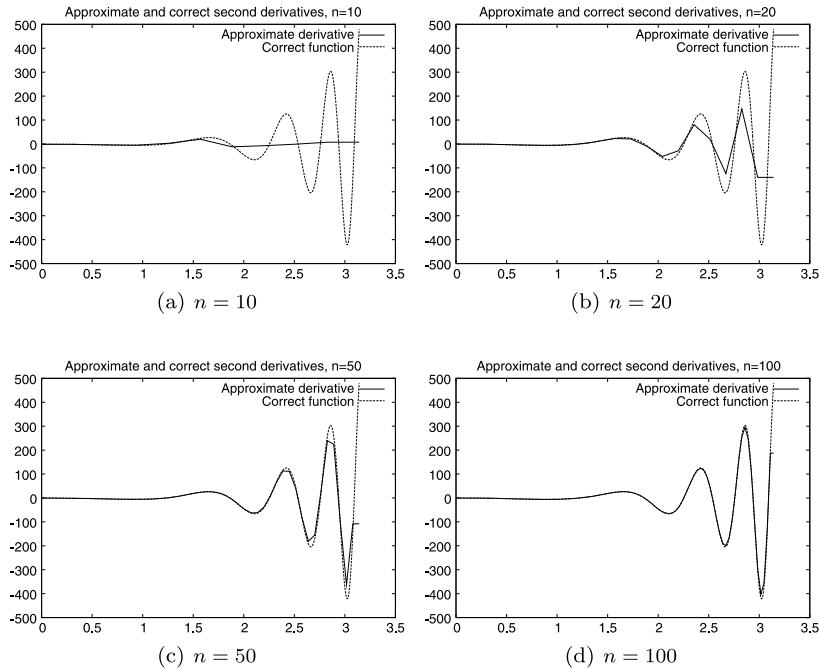

Fig. B.5 Plots of exact and approximate second-order derivatives with various mesh resolution n .

B.5 Exercises

Exercise B.1. *Interpolate a discrete function.*

In a Python function, represent the mathematical function

$$f(x) = \exp(-x^2) \cos(2\pi x)$$

on a mesh consisting of $q + 1$ equally spaced points on $[-1, 1]$, and return 1) the interpolated function value at $x = -0.45$ and 2) the error in the interpolated value. Call the function and write out the error for $q = 2, 4, 8, 16$. Name of program file: `interpolate_exp_cos.py` \diamond

Exercise B.2. *Study a function for different parameter values.*

Develop a program that creates a plot of the function $f(x) = \sin(\frac{1}{x+\varepsilon})$ for x in the unit interval, where $\varepsilon > 0$ is a given input parameter. Use $n + 1$ nodes in the plot.

- (a) Test the program using $n = 10$ and $\varepsilon = 1/5$.
- (b) Refine the program such that it plots the function for two values of n ; say n and $n + 10$.
- (c) How large do you have to choose n in order for the difference between these two functions to be less than 0.1? Hint: Each function gives an array. Create a `while` loop and use the `max` function of the arrays to retrieve the maximum value and compare these.
- (d) Let $\varepsilon = 1/10$, and repeat (c).
- (e) Let $\varepsilon = 1/20$, and repeat (c).
- (f) Try to find a formula for how large n needs to be for a given value of ε such that increasing n further does not change the plot so much that it is visible on the screen. Note that there is no exact answer to this question.

Name of program file: `plot_sin_eps.py`

◇

Exercise B.3. *Study a function and its derivative.*

Consider the function

$$f(x) = \sin\left(\frac{1}{x + \varepsilon}\right)$$

for x ranging from 0 to 1, and the derivative

$$f'(x) = \frac{-\cos\left(\frac{1}{x + \varepsilon}\right)}{(x + \varepsilon)^2}.$$

Here, ε is a given input parameter.

- (a) Develop a program that creates a plot of the derivative of $f = f(x)$ based on a finite difference approximation using n computational nodes. The program should also graph the exact derivative given by $f' = f'(x)$ above.
- (b) Test the program using $n = 10$ and $\varepsilon = 1/5$.
- (c) How large do you have to choose n in order for the difference between these two functions to be less than 0.1? Hint: Each function gives an array. Create a `while` loop and use the `max` function of the arrays to retrieve the maximum value and compare these.
- (d) Let $\varepsilon = 1/10$, and repeat (c).
- (e) Let $\varepsilon = 1/20$, and repeat (c).
- (f) Try determine experimentally how large n needs to be for a given value of ε such that increasing n further does not change the plot so much that you can view it on the screen. Note, again, that there is no exact solution to this problem.

Name of program file: `sin_deriv.py`

◇

Exercise B.4. *Use the Trapezoidal method.*

The purpose of this exercise is to test the program `trapezoidal.py`.

(a) Let

$$\bar{a} = \int_0^1 e^{4x} dx = \frac{1}{4}e^4 - \frac{1}{4}.$$

Compute the integral using the program `trapezoidal.py` and, for a given n , let $a(n)$ denote the result. Try to find, experimentally, how large you have to choose n in order for

$$|\bar{a} - a(n)| \leq \varepsilon$$

where $\varepsilon = 1/100$.

(b) Repeat (a) with $\varepsilon = 1/1000$.

(c) Repeat (a) with $\varepsilon = 1/10000$.

(d) Try to figure out, in general, how large n has to be in order for

$$|\bar{a} - a(n)| \leq \varepsilon$$

for a given value of ε .

Name of program file: `trapezoidal_test_exp.py` ◇

Exercise B.5. *Compute a sequence of integrals.*

(a) Let

$$\bar{b}_k = \int_0^1 x^k dx = \frac{1}{k+1},$$

and let $b_k(n)$ denote the result of using the program `trapezoidal.py` to compute $\int_0^1 x^k dx$. For $k = 4, 6$ and 8 , try to figure out, by doing numerical experiments, how large n needs to be in order for $b_k(n)$ to satisfy

$$|\bar{b}_k - b_k(n)| \leq 0.0001.$$

Note that n will depend on k . Hint: Run the program for each k , look at the output, and calculate $|\bar{b}_k - b_k(n)|$ manually.

(b) Try to generalize the result in (a) to arbitrary $k \geq 2$.

(c) Generate a plot of x^k on the unit interval for $k = 2, 4, 6, 8$, and 10 , and try to figure out if the results obtained in (a) and (b) are reasonable taking into account that the program `trapezoidal.py` was developed using a piecewise linear approximation of the function.

Name of program file: `trapezoidal_test_power.py` ◇

Exercise B.6. *Use the Trapezoidal method.*

The purpose of this exercise is to compute an approximation of the integral⁹

$$I = \int_{-\infty}^{\infty} e^{-x^2} dx$$

using the Trapezoidal method.

⁹ You may consult your Calculus book to verify that the exact solution is $\sqrt{\pi}$.

- (a) Plot the function e^{-x^2} for x ranging from -10 to 10 and use the plot to argue that

$$\int_{-\infty}^{\infty} e^{-x^2} dx = 2 \int_0^{\infty} e^{-x^2} dx.$$

- (b) Let $T(n, L)$ be the approximation of the integral

$$2 \int_0^L e^{-x^2} dx$$

computed by the Trapezoidal method using n computational points. Develop a program that computes the value of T for a given n and L .

- (c) Extend the program developed in (b) to write out values of $T(n, L)$ in a table with rows corresponding to $n = 100, 200, \dots, 500$ and columns corresponding to $L = 2, 4, 6, 8, 10$.
- (d) Extend the program to also print a table of the errors in $T(n, L)$ for the same n and L values as in (c). The exact value of the integral is $\sqrt{\pi}$.

Comment. Numerical integration of integrals with finite limits requires a choice of n , while with infinite limits we also need to truncate the domain, i.e., choose L in the present example. The accuracy depends on both n and L . Name of program file: `integrate_exp.py` \diamond

Exercise B.7. *Compute trigonometric integrals.*

The purpose of this exercise is to demonstrate a property of trigonometric functions that you will meet in later courses. In this exercise, you may compute the integrals using the program `trapezoidal.py` with $n = 100$.

- (a) Consider the integrals

$$I_{p,q} = 2 \int_0^1 \sin(p\pi x) \sin(q\pi x) dx$$

and fill in values of the integral $I_{p,q}$ in a table with rows corresponding to $q = 0, 1, \dots, 4$ and columns corresponding to $p = 0, 1, \dots, 4$.

- (b) Repeat (a) for the integrals

$$I_{p,q} = 2 \int_0^1 \cos(p\pi x) \cos(q\pi x) dx.$$

- (c) Repeat (a) for the integrals

$$I_{p,q} = 2 \int_0^1 \cos(p\pi x) \sin(q\pi x) dx.$$

Name of program file: `ortho_trig_funcs.py` \diamond

Exercise B.8. *Plot functions and their derivatives.*

- (a) Use the program `diff_func.py` to plot approximations of the derivative for the following functions defined on the interval ranging from $x = 1/1000$ to $x = 1$:

$$\begin{aligned} f(x) &= \ln\left(x + \frac{1}{100}\right), \\ g(x) &= \cos(e^{10x}), \\ h(x) &= x^x. \end{aligned}$$

- (b) Extend the program such that both the discrete approximation and the correct (analytical) derivative can be plotted. The analytical derivative should be evaluated in the same computational points as the numerical approximation. Test the program by comparing the discrete and analytical derivative of x^3 .
- (c) Use the program developed in (b) to compare the analytical and discrete derivatives of the functions given in (a). How large do you have to choose n in each case in order for the plots to become indistinguishable on your screen. Note that the analytical derivatives are given by:

$$\begin{aligned} f'(x) &= \frac{1}{x + \frac{1}{100}}, \\ g'(x) &= -10e^{10x} \sin(e^{10x}), \\ h'(x) &= (\ln x)x^x + xx^{x-1}. \end{aligned}$$

Name of program file: `diff_functions.py`

◇

Exercise B.9. *Use the Trapezoidal method.*

Develop an efficient program that creates a plot of the function

$$f(x) = \frac{1}{2} + \frac{1}{\sqrt{\pi}} \int_0^x e^{-t^2} dt$$

for $x \in [0, 10]$. The integral should be approximated using the Trapezoidal method and use as few function evaluations of e^{-t^2} as possible.

Name of program file: `plot_integral.py`

◇

This Appendix is Authored by Aslak Tveito

Differential equations have proven to be an immensely successful instrument for modeling phenomena in science and technology. It is hardly an exaggeration to say that differential equations are used to define mathematical models in virtually all parts of the natural sciences. In this chapter, we will take the first steps towards learning how to deal with differential equations on a computer. This is a core issue in Computational Science and reaches far beyond what we can cover in this text. However, the ideas you will see here are reused in lots of advanced applications, so this chapter will hopefully provide useful introduction to a topic that you will probably encounter many times later.

We will show you how to build programs for solving differential equations. More precisely, we will show how a differential equation can be formulated in a discrete manner suitable for analysis on a computer, and how to implement programs to compute the discrete solutions. The simplest differential equations can be solved analytically in the sense that you can write down an explicit formula for the solutions. However, differential equations arising in practical applications are usually rather complicated and thus have to be solved numerically on a computer. Therefore we focus on implementing numerical methods to solve the equations. Appendix E describes more advanced implementation techniques aimed at making an easy-to-use toolbox for solving differential equations. Exercises in the present appendix and Appendix E aim at solving a variety of differential equations arising in various disciplines of science.

As with all the other chapters, the source code can be found in `src`, in this case in the subdirectory `ode1`. The short form ODE (plural: ODEs) is commonly used as abbreviation for *ordinary differential equation*, which is the type of differential equation that we address

in this appendix. Actually, differential equations are divided into two groups: ordinary differential equations and partial differential equations. Ordinary differential equations contain derivatives with respect to one variable (usually t in our examples), whereas partial differential equations contain derivatives with respect to more than one variable, typically with respect to space and time. A typical ordinary differential equation is

$$u'(t) = u(t),$$

and a typical partial differential equation is

$$\frac{\partial u}{\partial t} = \frac{\partial^2 u}{\partial x^2} + \frac{\partial^2 u}{\partial y^2}.$$

The latter is known as the heat or diffusion equation.

C.1 The Simplest Case

Consider the problem of solving the following equation

$$u'(t) = t^3. \tag{C.1}$$

The solution can be computed directly by integrating (C.1), which gives

$$u(t) = \frac{1}{4}t^4 + C,$$

where C is an arbitrary constant. To obtain a unique solution, we need an extra condition to determine C . Specifying $u(t_1)$ for some time point t_1 represents a possible extra condition. It is common to view (C.1) as an equation for the function $u(t)$ for $t \in [0, T]$, and the extra condition is usually that the start value $u(0)$ is known. This is called the *initial condition*. Say

$$u(0) = 1. \tag{C.2}$$

In general, the solution of the differential equation (C.1) subject to the initial condition C.2 is¹

$$\begin{aligned} u(t) &= u(0) + \int_0^t u'(\tau) d\tau \\ &= 1 + \int_0^t \tau^3 d\tau \\ &= 1 + \frac{1}{4}t^4. \end{aligned}$$

Let us go back and check: Does $u(t) = 1 + \frac{1}{4}t^4$ really satisfy the two

¹ If you are confused by the use of t and τ , don't get too upset; you see: "In mathematics you don't understand things. You just get used to them." –John von Neumann, mathematician, 1903–1957.

requirements listed in (C.1) and (C.2)? Obviously, $u(0) = 1$, and $u'(t) = t^3$, so the solution is correct.

More generally, we consider the equation

$$u'(t) = f(t) \quad (\text{C.3})$$

together with the initial condition

$$u(0) = u_0. \quad (\text{C.4})$$

Here we assume that $f(t)$ is a given function, and that u_0 is a given number. Then, by reasoning as above, we have

$$u(t) = u_0 + \int_0^T f(\tau) d\tau. \quad (\text{C.5})$$

By using the methods introduced in Appendix B, we can find a discrete version of u by approximating the integral. Generally, an approximation of the integral

$$\int_0^T f(\tau) d\tau$$

can be computed using the discrete version of a continuous function $f(\tau)$ defined on an interval $[0, t]$. The discrete version of f is given by $(\tau_i, y_i)_{i=0}^n$ where

$$\tau_i = ih, \text{ and } y_i = f(\tau_i)$$

for $i = 0, 1, \dots, n$. Here $n \geq 1$ is a given integer and $h = T/n$. The Trapezoidal rule can now be written as

$$\int_0^T f(\tau) d\tau \approx \frac{h}{2} \left[y_0 + 2 \sum_{k=1}^{n-1} y_k + y_n \right]. \quad (\text{C.6})$$

By using this approximation, we find that an approximate solution of (C.3)–(C.4) is given by

$$u(t) \approx u_0 + \frac{h}{2} \left[y_0 + 2 \sum_{k=1}^{n-1} y_k + y_n \right].$$

The program `integrate_ode.py` computes a numerical solution of (C.3)–(C.4), where the function f , the time t , the initial condition u_0 , and the number of time-steps n are inputs to the program.

```
def integrate(T, n, u0):
    h = T/float(n)
    t = linspace(0, T, n+1)
    I = f(t[0])
    for k in iseq(1, n-1, 1):
        I += 2*f(t[k])
    I += f(t[-1])
    I *= (h/2)
```

```

    I += u0
    return I

from scitools.std import *
f_formula = sys.argv[1]
T = eval(sys.argv[2])
u0 = eval(sys.argv[3])
n = int(sys.argv[4])

f = StringFunction(f_formula, independent_variables='t')
print "Numerical solution of u'(t)=t**3: ", integrate(T, n, u0)

```

We apply the program for computing the solution of

$$u'(t) = te^{t^2},$$

$$u(0) = 0,$$

at time $T = 2$ using $n = 10, 20, 50$ and 100 :

```

Terminal
integrate_ode.py't*exp(t**2)' 2 0 10
Numerical solution of u'(t)=t**3: 28.4066160877

```

```

Terminal
integrate_ode.py't*exp(t**2)' 2 0 20
Numerical solution of u'(t)=t**3: 27.2059977451

```

```

Terminal
integrate_ode.py't*exp(t**2)' 2 0 50
Numerical solution of u'(t)=t**3: 26.86441489

```

```

Terminal
integrate_ode.py't*exp(t**2)' 2 0 100
Numerical solution of u'(t)=t**3: 26.8154183399

```

The exact solution is given by $\frac{1}{2}e^{2^2} - \frac{1}{2} \approx 26.799$, so we see that the approximate solution becomes better as n is increased, as expected.

C.2 Exponential Growth

The example above was really not much of a differential equation, because the solution was obtained by straightforward integration. Equations of the form

$$u'(t) = f(t) \tag{C.7}$$

arise in situations where we can explicitly specify the derivative of the unknown function u . Usually, the derivative is specified in terms

of the solution itself. Consider, for instance, population growth under idealized conditions as modeled in Appendix A.1.4. We introduce the symbol v_i for the number of individuals at time τ_i (v_i corresponds to x_n in Appendix A.1.4). The basic model for the evolution of v_i is (A.9):

$$v_i = (1 + r)v_{i-1}, \quad i = 1, 2, \dots, \text{ and } v_0 \text{ known.} \quad (\text{C.8})$$

As mentioned in Appendix A.1.4, r depends on the time difference $\Delta\tau = \tau_i - \tau_{i-1}$: the larger $\Delta\tau$ is, the larger r is. It is therefore natural to introduce a growth rate α that is independent of $\Delta\tau$: $\alpha = r/\Delta\tau$. The number α is then fixed regardless of how long jumps in time we take in the difference equation for v_i . In fact, α equals the growth in percent, divided by 100, over a time interval of unit length.

The difference equation now reads

$$v_i = v_{i-1} + \alpha\Delta\tau v_{i-1}.$$

Rearranging this equation we get

$$\frac{v_i - v_{i-1}}{\Delta\tau} = \alpha v_{i-1}. \quad (\text{C.9})$$

Assume now that we shrink the time step $\Delta\tau$ to a small value. The left-hand side of (C.9) is then an approximation to the time-derivative of a function $v(\tau)$ expressing the number of individuals in the population at time τ . In the limit $\Delta\tau \rightarrow 0$, the left-hand side becomes the derivative exactly, and the equation reads

$$v'(\tau) = \alpha v(\tau). \quad (\text{C.10})$$

As for the underlying difference equation, we need a start value $v(0) = v_0$. We have seen that reducing the time step in a difference equation to zero, we get a differential equation.

Many like to scale an equation like (C.10) such that all variables are without physical dimensions and their maximum absolute value is typically of the order of unity. In the present model, this means that we introduce new dimensionless variables

$$u = \frac{v}{v_0}, \quad t = \frac{\tau}{\alpha}$$

and derive an equation for $u(t)$. Inserting $v = v_0 u$ and $\tau = \alpha t$ in (C.10) gives the prototype equation for population growth:

$$u'(t) = u(t) \quad (\text{C.11})$$

with the initial condition

$$u(0) = 1. \quad (\text{C.12})$$

When we have computed the dimensionless $u(t)$, we can find the function $v(\tau)$ as

$$v(\tau) = v_0 u(\tau/\alpha).$$

We shall consider practical applications of population growth equations later, but let's start by looking at the idealized case (C.11).

Analytical Solution. Our differential equation can be written in the form

$$\frac{du}{dt} = u,$$

which can be rewritten as

$$\frac{du}{u} = dt,$$

and then integration on both sides yields

$$\ln(u) = t + c,$$

where c is a constant that has to be determined by using the initial condition. Putting $t = 0$, we have

$$\ln(u(0)) = c,$$

hence

$$c = \ln(1) = 0,$$

and then

$$\ln(u) = t,$$

so we have the solution

$$u(t) = e^t. \tag{C.13}$$

Let us now check that this function really solves (C.7, C.11). Obviously, $u(0) = e^0 = 1$, so (C.11) is fine. Furthermore

$$u'(t) = e^t = u(t),$$

thus (C.7) also holds.

Numerical Solution. We have seen that we can find a formula for the solution of the equation of exponential growth. So the problem is solved, and it is trivial to write a program to graph the solution. We will, however, go one step further and develop a numerical solution strategy for this problem. We don't really need such a method for this problem since the solution is available in terms of a formula, but as mentioned earlier, it is good practice to develop methods for problems where we know the solution; then we are more confident when we are confronted with more challenging problems.

Suppose we want to compute a numerical approximation of the solution of

$$u'(t) = u(t) \tag{C.14}$$

equipped with the initial condition

$$u(0) = 1. \tag{C.15}$$

We want to compute approximations from time $t = 0$ to time $t = 1$. Let $n \geq 1$ be a given integer, and define

$$\Delta t = 1/n. \tag{C.16}$$

Furthermore, let u_k denote an approximation of $u(t_k)$ where

$$t_k = k\Delta t \tag{C.17}$$

for $k = 0, 1, \dots, n$. The key step in developing a numerical method for this differential equation is to invoke the Taylor series as applied to the exact solution,

$$u(t_{k+1}) = u(t_k) + \Delta t u'(t_k) + O(\Delta t^2), \tag{C.18}$$

which implies that

$$u'(t_k) \approx \frac{u(t_{k+1}) - u(t_k)}{\Delta t}. \tag{C.19}$$

By using (C.14), we get

$$\frac{u(t_{k+1}) - u(t_k)}{\Delta t} \approx u(t_k). \tag{C.20}$$

Recall now that $u(t_k)$ is the exact solution at time t_k , and that u_k is the approximate solution at the same point in time. We now want to determine u_k for all $k \geq 0$. Obviously, we start by defining

$$u_0 = u(0) = 1.$$

Since we want $u_k \approx u(t_k)$, we require that u_k satisfy the following equality

$$\frac{u_{k+1} - u_k}{\Delta t} = u_k \tag{C.21}$$

motivated by (C.20). It follows that

$$u_{k+1} = (1 + \Delta t)u_k. \tag{C.22}$$

Since u_0 is known, we can compute u_1, u_2 and so on by using the formula above. The formula is implemented² in the program `exp_growth.py`.

² Actually, we do not need the method and we do not need the program. It follows from (C.22) that

$$u_k = (1 + \Delta t)^k u_0$$

```

def compute_u(u0, T, n):
    """Solve u'(t)=u(t), u(0)=u0 for t in [0,T] with n steps."""
    u = u0
    dt = T/float(n)
    for k in range(0, n, 1):
        u = (1+dt)*u
    return u # u(T)

import sys
n = int(sys.argv[1])

# Special test case: u'(t)=u, u(0)=1, t in [0,1]
T = 1; u0 = 1
print 'u(1) =', compute_u(u0, T, n)

```

Observe that we do not store the u values: We just overwrite a `float` object u by its new value. This saves a lot of storage if n is large.

Running the program for $n = 5, 10, 20$ and 100 , we get the approximations $2.4883, 2.5937, 2.6533$, and 2.7048 . The exact solution at time $t = 1$ is given by $u(1) = e^1 \approx 2.7183$, so again the approximations become better as n is increased.

An alternative program, where we plot $u(t)$ and therefore store all the u_k and $t_k = k\Delta t$ values, is shown below.

```

def compute_u(u0, T, n):
    """Solve u'(t)=u(t), u(0)=u0 for t in [0,T] with n steps."""
    t = linspace(0, T, n+1)
    t[0] = 0
    u = zeros(n+1)
    u[0] = u0
    dt = T/float(n)
    for k in range(0, n, 1):
        u[k+1] = (1+dt)*u[k]
        t[k+1] = t[k] + dt
    return u, t

from scitools.std import *
n = int(sys.argv[1])

# Special test case: u'(t)=u, u(0)=1, t in [0,1]
T = 1; u0 = 1
u, t = compute_u(u0, T, n)
plot(t, u)
tfine = linspace(0, T, 1001) # for accurate plot
v = exp(tfine) # correct solution
hold('on')
plot(tfine, v)
legend(['Approximate solution', 'Correct function'])
title('Approximate and correct discrete functions, n=%d' % n)
savefig('tmp.eps')

```

Using the program for $n = 5, 10, 20$, and 100 , results in the plots in Figure C.1. The convergence towards the exponential function is evident from these plots.

for $k = 0, 1, \dots, n$ which can be evaluated on a pocket calculator or even on your cellular phone. But again, we show examples where everything is as simple as possible (but not simpler!) in order to prepare your mind for more complex matters ahead.

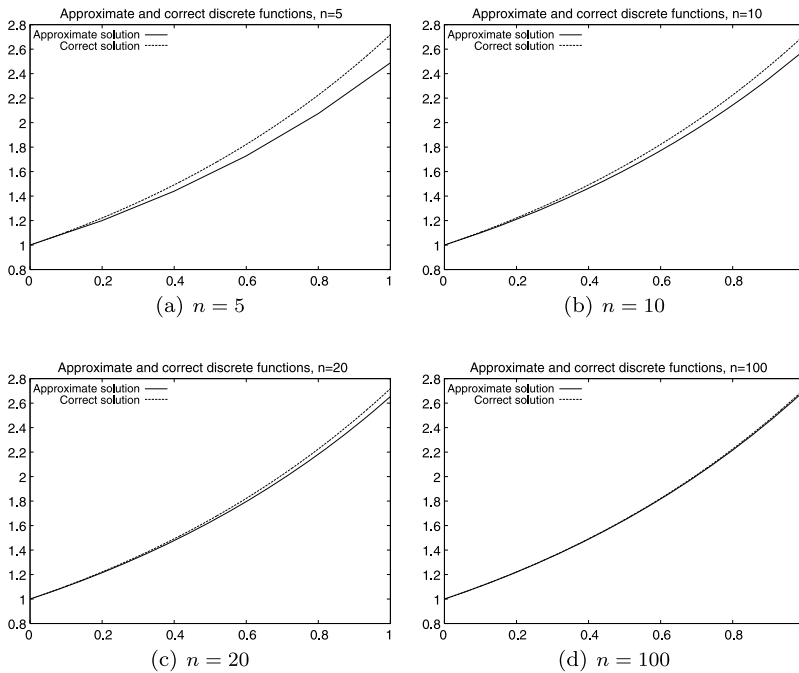

Fig. C.1 Plots of exact and approximate solutions of $u'(t) = u(t)$ with varying number of time steps in $[0, 1]$.

C.3 Logistic Growth

Exponential growth can be modelled by the following equation

$$u'(t) = \alpha u(t)$$

where $\alpha > 0$ is a given constant. If the initial condition is given by

$$u(0) = u_0$$

the solution is given by

$$u(t) = u_0 e^{\alpha t}.$$

Since $\alpha > 0$, the solution becomes very large as t increases. For a short time, such growth of a population may be realistic, but over a longer time, the growth of a population is restricted due to limitations of the environment, as discussed in Appendix A.1.5. Introducing a logistic growth term as in (A.12) we get the differential equation

$$u'(t) = \alpha u(t) \left(1 - \frac{u(t)}{R} \right), \quad (\text{C.23})$$

where α is the growth-rate, and R is the carrying capacity (which corresponds to M in Appendix A.1.5). Note that R is typically very

large, so if $u(0)$ is small, we have

$$\frac{u(t)}{R} \approx 0$$

for small values of t , and thus we have exponential growth for small t ;

$$u'(t) \approx au(t).$$

But as t increases, and u grows, the term $u(t)/R$ will become important and limit the growth.

A numerical scheme for the logistic equation (C.23) is given by

$$\frac{u_{k+1} - u_k}{\Delta t} = \alpha u_k \left(1 - \frac{u_k}{R}\right),$$

which we can solve with respect to the unknown u_{k+1} :

$$u_{k+1} = u_k + \Delta t \alpha u_k \left(1 - \frac{u_k}{R}\right). \quad (\text{C.24})$$

This is the form of the equation that is suited for implementation.

C.4 A Simple Pendulum

So far we have considered scalar ordinary differential equations, i.e., equations with one single function $u(t)$ as unknown. Now we shall deal with systems of ordinary differential equations, where in general n unknown functions are coupled in a system of n equations. Our introductory example will be a system of two equations having two unknown functions $u(t)$ and $v(t)$. The example concerns the motion of a pendulum, see Figure C.2. A sphere with mass m is attached to a massless rod of length L and oscillates back and forth due to gravity. Newton's second law of motion applied to this physical system gives rise the differential equation

$$\theta''(t) + \alpha \sin(\theta) = 0 \quad (\text{C.25})$$

where $\theta = \theta(t)$ is the angle the rod makes with the vertical, measured in radians, and $\alpha = g/L$ (g is the acceleration of gravity). The unknown function to solve for is θ , and knowing θ , we can quite easily compute the position of the sphere, its velocity, and its acceleration, as well as the tension force in the rod. Since the highest derivative in (C.25) is of second order, we refer to (C.25) as a *second-order differential equation*. Our previous examples in this chapter involved only first-order derivatives, and therefore they are known as *first-order differential equations*.

Equation (C.25) can be solved by the same numerical method as we use in Appendix D.1.2, because (C.25) is very similar to Equation D.8,

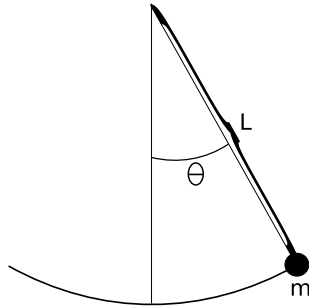

Fig. C.2 A pendulum with $m =$ mass, $L =$ length of massless rod and $\theta = \theta(t) =$ angle.

which is the topic of Appendix D. The only difference is that D.8 has extra terms, which can be skipped, while the kS term in D.8 must be extended to $\alpha \sin(S)$ to make D.8 identical to (C.25). This extension is easily performed. However, here we shall not solve the second-order equation (C.25) as it stands. We shall instead rewrite it as a system of two first-order equations so that we can use numerical methods for first-order equations to solve it.

To transform a second-order equation to a system of two first-order equations, we introduce a new variable for the first-order derivative (the angular velocity of the sphere): $v(t) = \theta'(t)$. Using v and θ in (C.25) yields

$$v'(t) + \alpha \sin(\theta) = 0.$$

In addition, we have the relation

$$v = \theta'(t)$$

between v and θ . This means that (C.25) is equivalent to the following system of two coupled first-order differential equations:

$$\theta'(t) = v(t), \tag{C.26}$$

$$v'(t) = -\alpha \sin(\theta). \tag{C.27}$$

As for scalar differential equations, we need initial conditions, now two conditions because we have two unknown functions:

$$\theta(0) = \theta_0,$$

$$v(0) = v_0.$$

Here we assume the initial angle θ_0 and the initial angular velocity v_0 to be given.

It is common to group the unknowns and the initial conditions in 2-vectors: $(\theta(t), v(t))$ and (θ_0, v_0) . One may then view (C.26)–(C.27) as a *vector equation*, whose first component equation is (C.26), and the second component equation is (C.27). In Python software, this vector

notation makes solution methods for scalar equations (almost) immediately available for vector equations, i.e., systems of ordinary differential equations.

In order to derive a numerical method for the system (C.26)–(C.27), we proceed as we did above for one equation with one unknown function. Say we want to compute the solution from $t = 0$ to $t = T$ where $T > 0$ is given. Let $n \geq 1$ be a given integer and define the time step

$$\Delta t = T/n.$$

Furthermore, we let (θ_k, v_k) denote approximations of the exact solution $(\theta(t_k), v(t_k))$ for $k = 0, 1, \dots, n$. A Forward Euler type of method will now read

$$\frac{\theta_{k+1} - \theta_k}{\Delta t} = v_k, \quad (\text{C.28})$$

$$\frac{v_{k+1} - v_k}{\Delta t} = -\alpha \sin(\theta_k). \quad (\text{C.29})$$

This scheme can be rewritten in a form more suitable for implementation:

$$\theta_{k+1} = \theta_k + \Delta t v_k, \quad (\text{C.30})$$

$$v_{k+1} = v_k - \alpha \Delta t \sin(\theta_k). \quad (\text{C.31})$$

The next program, `pendulum.py`, implements this method in the function `pendulum`. The input parameters to the model, θ_0 , v_0 , the final time T , and the number of time-steps n , must be given on the command line.

```
def pendulum(T, n, theta0, v0, alpha):
    """Return the motion (theta, v, t) of a pendulum."""
    dt = T/float(n)
    t = linspace(0, T, n+1)
    v = zeros(n+1)
    theta = zeros(n+1)
    v[0] = v0
    theta[0] = theta0
    for k in range(n):
        theta[k+1] = theta[k] + dt*v[k]
        v[k+1] = v[k] - alpha*dt*sin(theta[k+1])
    return theta, v, t

from scitools.std import *
n = int(sys.argv[1])
T = eval(sys.argv[2])
v0 = eval(sys.argv[3])
theta0 = eval(sys.argv[4])
alpha = eval(sys.argv[5])

theta, v, t = pendulum(T, n, theta0, v0)
plot(t, v, xlabel='t', ylabel='velocity')
figure()
plot(t, theta, xlabel='t', ylabel='velocity')
```

By running the program with the input data $\theta_0 = \pi/6$, $v_0 = 0$, $\alpha = 5$, $T = 10$ and $n = 1000$, we get the results shown in Figure C.3. The angle $\theta = \theta(t)$ is displayed in the left panel and the velocity is given in the right panel.

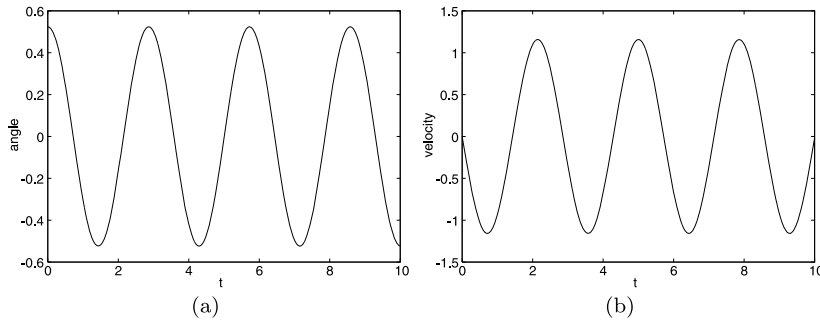

Fig. C.3 Motion of a pendulum: (a) the angle $\theta(t)$, and (b) the angular velocity θ' .

C.5 A Model for the Spread of a Disease

Mathematical models are used intensively to analyze the spread of infectious diseases³. In the simplest case, we may consider a population, that is supposed to be constant, consisting of two groups; the susceptibles (S) who can catch the disease, and the infectives (I) who have the disease and are able to transmit it. A system of differential equations modelling the evolution of S and I is given by

$$S' = -rSI, \quad (\text{C.32})$$

$$I' = rSI - aI. \quad (\text{C.33})$$

Here r and a are given constants reflecting the characteristics of the epidemic. The initial conditions are given by

$$S(0) = S_0,$$

$$I(0) = I_0,$$

where the initial state (S_0, I_0) is assumed to be known.

Suppose we want to compute numerical solutions of this system from time $t = 0$ to $t = T$. Then, by reasoning as above, we introduce the time step

$$\Delta t = T/n$$

³ The interested reader may consult the excellent book [10] on Mathematical Biology by J.D. Murray for an introduction to such models.

and the approximations (S_k, I_k) of the solution $(S(t_k), I(t_k))$. An explicit Forward Euler method for the system takes the following form,

$$\frac{S_{k+1} - S_k}{\Delta t} = -rS_kI_k,$$

$$\frac{I_{k+1} - I_k}{\Delta t} = rS_kI_k - aI_k,$$

which can be rewritten on computational form

$$S_{k+1} = S_k - \Delta trS_kI_k,$$

$$I_{k+1} = I_k + \Delta t(rS_kI_k - aI_k).$$

This scheme is implemented in the program `exp_epidemic.py` where r, a, S_0, I_0, n and T are input data given on the command line. The function `epidemic` computes the solution (S, I) to the differential equation system. This pair of time-dependent functions is then plotted in two separate plots.

```
def epidemic(T, n, S0, I0, r, a):
    dt = T/float(n)
    t = linspace(0, T, n+1)
    S = zeros(n+1)
    I = zeros(n+1)
    S[0] = S0
    I[0] = I0
    for k in range(n):
        S[k+1] = S[k] - dt*r*S[k]*I[k]
        I[k+1] = I[k] + dt*(r*S[k]*I[k] - a*I[k])
    return S, I, t

from scitools.std import *
n = int(sys.argv[1])
T = eval(sys.argv[2])
S0 = eval(sys.argv[3])
I0 = eval(sys.argv[4])
r = eval(sys.argv[5])
a = eval(sys.argv[6])

S, I, t = epidemic(T, n, S0, I0, r, a)
plot(t, S, xlabel='t', ylabel='Susceptibles')
plot(t, I, xlabel='t', ylabel='Infectives')
```

We want to apply the program to a specific case where an influenza epidemic hit a British boarding school with a total of 763 boys⁴. The epidemic lasted from 21st January to 4th February in 1978. We let $t = 0$ denote 21st of January and we define $T = 14$ days. We put $S_0 = 762$ and $I_0 = 1$ which means that one person was ill at $t = 0$. In the Figure C.4 we see the numerical results using $r = 2.18 \times 10^{-3}$, $a = 0.44$, $n = 1000$. Also, we have plotted actual the measurements, and we note that the simulations fit the real data quite well.

⁴ The data are from Murray [10], and Murray found the data in the British Medical Journal, March 4, 1978.

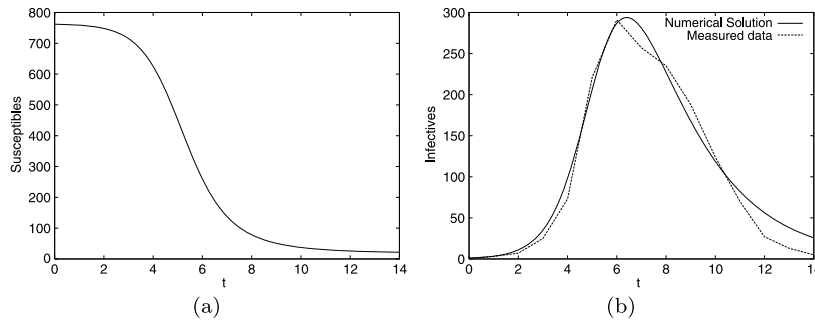

Fig. C.4 Graphs of (a) susceptibles and (b) infectives for an influenza in a British boarding school in 1978.

C.6 Exercises

Exercise C.1. *Solve a nonhomogeneous linear ODE.*

Solve the ODE problem

$$u' = 2u - 1, \quad u(0) = 2, \quad t \in [0, 6]$$

using the Forward Euler method. Choose $\Delta t = 0.25$. Plot the numerical solution together with the exact solution $u(t) = \frac{1}{2} + \frac{3}{2}e^{2t}$. Name of program file: `nonhomogeneous_linear_ODE.py`. \diamond

Exercise C.2. *Solve a nonlinear ODE.*

Solve the ODE problem

$$u' = u^q, \quad u(0) = 1, \quad t \in [0, T]$$

using the Forward Euler method. The exact solution reads $u(t) = e^t$ for $q = 1$ and $u(t) = (t(1 - q) + 1)^{1/(1-q)}$ for $q > 1$ and $t(1 - q) + 1 > 0$. Read q , Δt , and T from the command line, solve the ODE, and plot the numerical and exact solution. Run the program for different cases: $q = 2$ and $q = 3$, with $\Delta t = 0.01$ and $\Delta t = 0.1$. Set $T = 6$ if $q = 1$ and $T = 1/(q - 1) - 0.1$ otherwise. Name of program file: `nonlinear_ODE.py`. \diamond

Exercise C.3. *Solve an ODE for $y(x)$.*

We have given the following ODE problem:

$$\frac{dy}{dx} = \frac{1}{2(y - 1)}, \quad y(0) = 1 + \sqrt{\epsilon}, \quad x \in [0, 4], \quad (\text{C.34})$$

where $\epsilon > 0$ is a small number. Formulate a Forward Euler method for this ODE problem and compute the solution for varying step size in x : $\Delta x = 1$, $\Delta x = 0.25$, $\Delta x = 0.01$. Plot the numerical solutions together with the exact solution $y(x) = 1 + \sqrt{x + \epsilon}$, using 1001 x coordinates for accurate resolution of the latter. Set ϵ to 10^{-3} . Study the numerical

solution with $\Delta x = 1$, and use that insight to explain why this problem is hard to solve numerically. Name of program file: `yx_ode.py`. \diamond

Exercise C.4. *Experience instability of an ODE.*

Consider the ODE problem

$$u' = \alpha u, \quad u(0) = u_0,$$

solved by the Forward Euler method. Show by repeatedly applying the scheme that

$$u_k = (1 + \alpha \Delta t)^k u_0.$$

We now turn to the case $\alpha < 0$. Show that the numerical solution will oscillate if $\Delta t > -1/\alpha$. Make a program for computing u_k , set $\alpha = -1$, and demonstrate oscillatory solutions for $\Delta t = 1.1, 1.5, 1.9$. Recall that the exact solution, $u(t) = e^{\alpha t}$, never oscillates.

What happens if $\Delta t > -2/\alpha$? Try it out in the program and explain then mathematically why not $u_k \rightarrow 0$ as $k \rightarrow \infty$. Name of program file: `unstable_ode.py`. \diamond

Exercise C.5. *Solve an ODE with time-varying growth.*

Consider the ODE for exponential growth,

$$u' = \alpha u, \quad u(0) = 1, \quad t \in [0, T].$$

Now we introduce a time-dependent α such that the growth decreases with time: $\alpha(t) = a - bt$. Solve the problem for $a = 1$, $b = 0.1$, and $T = 10$. Plot the solution and compare with the corresponding exponential growth using the mean value of $\alpha(t)$ as growth factor: $e^{(a-bT/2)t}$. Name of program file: `time_dep_growth.py`. \diamond

The examples in the ordinary chapters of this book are quite compact and composed to convey programming constructs in a gentle pedagogical way. In this appendix the idea is to solve a more comprehensive real-world problem by programming. The problem solving process gets quite advanced because we bring together elements from physics, mathematics, and programming, in a way that a scientific programmer must master. Each individual element is quite straightforward in the sense that you have probably met the element already, either in high school physics or mathematics, or in this book. The challenge is to understand the problem, and analyze it by breaking it into a set of simpler elements. It is not necessary to understand this problem solving process in detail. As a computer programmer, all you need to understand is how you translate the given algorithm into a working program and how to test the program. We anticipate that this task should be doable without a thorough understanding of the physics and mathematics of the problem.

You can read the present appendix after the material from Chapters 1–5 is digested. More specifically, you can read Appendices D.1 and D.2 after Chapter 4, while Appendix D.3 requires knowledge about curve plotting from Chapter 5.

All Python files associated with this appendix are found in `src/box_spring`.

D.1 About the Problem: Motion and Forces in Physics

D.1.1 The Physical Problem

We shall study a simple device which models oscillating systems. A box with mass m and height b is attached to a spring of length L as shown in Figure D.1. The end of the spring is attached to a plate which we

can move up and down with a displacement $w(t)$, where t denotes time. There are two ways the box can be set in motion: we can either stretch or compress the string initially by moving the box up or down, or we can move the plate. If $w = 0$ the box oscillates freely, otherwise we have what is called driven oscillations.

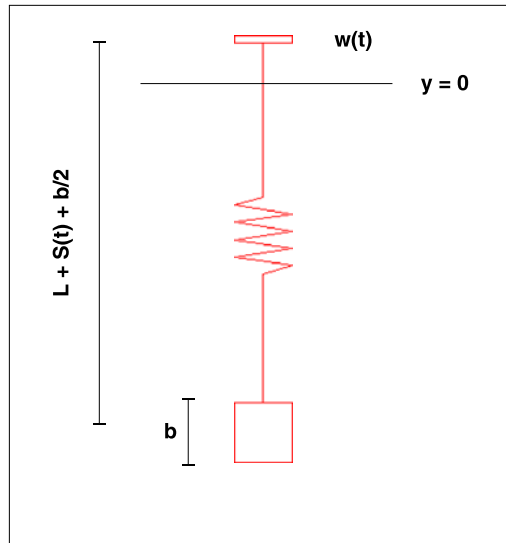

Fig. D.1 An oscillating system with a box attached to a spring.

Why will such a system oscillate? When the box moves downward, the spring is stretched, which results in a force that tries to move the box upward. The more we stretch the spring, the bigger the force against the movement becomes. The box eventually stops and starts moving upward with an upward acceleration. At some point the spring is not stretched anymore and there is no spring force on the box, but because of inertia, the box continues its motion upward. This causes the spring to get compressed, causing a force from the spring on the box that acts downward, against the upward movement. The downward force increases in intensity and manages to stop the upward motion. The process repeats itself and results in an oscillatory motion of the box. Since the spring tries to restore the position of the box, we refer to the spring force as a *restoring force*.

You have probably experienced that oscillations in such springs tend to die out with time. There is always a *damping force* that works against the motion. This damping force may be due to a not perfectly elastic string, and the force can be quite small, but we can also explicitly attach the spring to a damping mechanism to obtain a stronger, controllable damping of the oscillations (as one wants in a car or a mountain bike). We will assume that there is some damping force present in our sys-

tem, and this can well be a damping mechanism although this is not explicitly included in Figure D.1.

Oscillating systems of the type depicted in Figure D.1 have a huge number of applications throughout science and technology. One simple example is the spring system in a car or bicycle, which you have probably experienced on a bumpy road (the bumps lead to a $w(t)$ function). When your washing machine jumps up and down, it acts as a highly damped oscillating system (and the $w(t)$ function is related to uneven distribution of the mass of the clothes). The pendulum in a wall clock is another oscillating system, not with a spring, but physically the system can (for small oscillations) be modeled as a box attached to a spring because gravity makes a spring-like force on a pendulum (in this case, $w(t) = 0$). Other examples on oscillating systems where this type of equation arise are briefly mentioned in Exercise E.44. The bottom line is that understanding the dynamics of Figure D.1 is the starting point for understanding the behavior of a wide range of oscillating phenomena in nature and technical devices.

Goal of the Computations. Our aim is to compute the position of the box as a function of time. If we know the position, we can compute the velocity, the acceleration, the spring force, and the damping force. The mathematically difficult thing is to calculate the position – everything else is much easier¹.

We assume that the box moves in the vertical direction only, so we introduce $Y(t)$ as the vertical position of the center point of the box. We shall derive a mathematical equation that has $Y(t)$ as solution. This equation can be solved by an algorithm which can be implemented in a program. Our focus is on the implementation, since this is a book about programming, but for the reader interested in how computers play together with physics and mathematics in science and technology, we also outline how the equation and algorithm arise.

The Key Quantities. Let S be the stretch of the spring, where $S > 0$ means stretch and $S < 0$ implies compression. The length of the spring when it is unstretched is L , so at a given point of time t the actual length is $L + S(t)$. Given the position of the plate, $w(t)$, the length of the spring, $L + S(t)$, and the height of the box, b , the position $Y(t)$ is then, according to Figure D.1,

$$Y(t) = w(t) - (L + S(t)) - \frac{b}{2}. \quad (\text{D.1})$$

¹ More precisely, to compute the position we must solve a differential equation while the other quantities can be computed by differentiation and simple arithmetics. Solving differential equations is historically considered very difficult, but computers have simplified this task dramatically. Appendices C and E are devoted to this topic.

You can think as follows: We first “go up” to the plate at $y = w(t)$, then down $L + S(t)$ along the spring and then down $b/2$ to the center of the box. While L , w , and b must be known as input data, $S(t)$ is unknown and will be output data from the program.

D.1.2 The Computational Algorithm

Let us now go straight to the programming target and present the recipe for computing $Y(t)$. The algorithm below actually computes $S(t)$, but at any point of time we can easily find $Y(t)$ from (D.1) if we know $S(t)$. The $S(t)$ function is computed at discrete points of time, $t = t_i = i\Delta t$, for $i = 0, 1, \dots, N$. We introduce the notation S_i for $S(t_i)$. The S_i values can be computed by the following algorithm.

1. Set initial stretch S_0 from input data
2. Compute S_1 by

$$S_{i+1} = \frac{1}{2m} (2mS_i - \Delta t^2 kS_i + m(w_{i+1} - 2w_i + w_{i-1}) + \Delta t^2 mg), \quad (\text{D.2})$$

with $i = 0$.

3. For $i = 1, 2, \dots, N - 1$, compute S_{i+1} by

$$S_{i+1} = (m + \gamma)^{-1} (2mS_i - mS_{i-1} + \gamma\Delta t S_{i-1} - \Delta t^2 kS_i + m(w_{i+1} - 2w_i + w_{i-1}) + \Delta t^2 mg). \quad (\text{D.3})$$

The parameter γ equals $\frac{1}{2}\beta\Delta t$. The input data to the algorithm are the mass of the box m , a coefficient k characterizing the spring, a coefficient β characterizing the amount of damping in the system, the acceleration of gravity g , the movement of the plate $w(t)$, the initial stretch of the spring S_0 , the number of time steps N , and the time Δt between each computation of S values. The smaller we choose Δt , the more accurate the computations become.

Now you have two options, either read the derivation of this algorithm in Appendix D.1.3–D.1.4 or jump right to implementation in Appendix D.2.

D.1.3 Derivation of the Mathematical Model

To derive the algorithm we need to make a mathematical model of the oscillating system. This model is based on physical laws. The most important physical law for a moving body is Newton’s second law of motion:

$$F = ma, \quad (\text{D.4})$$

where F is the sum of all forces on the body, m is the mass of the body, and a is the acceleration of the body. The body here is our box.

Let us first find all the forces on the box. Gravity acts downward with magnitude mg . We introduce $F_g = -mg$ as the gravity force, with a minus sign because a negative force acts downward, in negative y direction.

The spring force on the box acts upward if the spring is stretched, i.e., if $S > 0$ we have a positive spring force F_s . The size of the force is proportional to the amount of stretching, so we write² $F_s = kS$, where k is commonly known as the *spring constant*. We also assume that we have a damping force that is always directed toward the motion and proportional with the “velocity of the stretch”, $-dS/dt$. Naming the proportionality constant β , we can write the damping force as $F_d = \beta dS/dt$. Note that when $dS/dt > 0$, S increases in time and the box moves downward, the F_d force then acts upward, against the motion, and must be positive. This is the way we can check that the damping force expression has the right sign.

The sum of all forces is now

$$\begin{aligned} F &= F_g + F_s + F_d, \\ &= -mg + kS + \beta \frac{dS}{dt}. \end{aligned} \quad (\text{D.5})$$

We now know the left-hand side of (D.4), but S is unknown to us. The acceleration a on the right-hand side of (D.4) is also unknown. However, acceleration is related to movement and the S quantity, and through this relation we can eliminate a as a second unknown. From physics, it is known that the acceleration of a body is the second derivative in time of the position of the body, so in our case,

$$\begin{aligned} a &= \frac{d^2 Y}{dt^2}, \\ &= \frac{d^2 w}{dt^2} - \frac{d^2 S}{dt^2}, \end{aligned} \quad (\text{D.6})$$

(remember that L and b are constant).

Equation (D.4) now reads

$$-mg + kS + \beta \frac{dS}{dt} = m \left(\frac{d^2 w}{dt^2} - \frac{d^2 S}{dt^2} \right). \quad (\text{D.7})$$

It is common to collect the unknown terms on the left-hand side and the known quantities on the right-hand side, and let higher-order derivatives appear before lower-order derivatives. With such a reordering of terms we get

² Spring forces are often written in the canonical form “ $F = -kx$ ”, where x is the stretch. The reason that we have no minus sign is that our stretch S is positive in the downward (negative) direction.

$$m \frac{d^2 S}{dt^2} + \beta \frac{dS}{dt} + kS = m \frac{d^2 w}{dt^2} + mg. \quad (\text{D.8})$$

This is the equation governing our physical system. If we solve the equation for $S(t)$, we have the position of the box according to (D.1), the velocity v as

$$v(t) = \frac{dY}{dt} = \frac{dw}{dt} - \frac{dS}{dt}, \quad (\text{D.9})$$

the acceleration as (D.6), and the various forces can be easily obtained from the formulas in (D.5).

A key question is if we can solve (D.8). If $w = 0$, there is in fact a well-known solution which can be written

$$S(t) = \frac{m}{k}g + \begin{cases} e^{-\zeta t}(c_1 e^{t\sqrt{\beta^2-1}} + c_2 e^{-t\sqrt{\beta^2-1}}), & \zeta > 1, \\ e^{-\zeta t}(c_1 + c_2 t), & \zeta = 1, \\ e^{-\zeta t}[c_1 \cos(\sqrt{1-\zeta^2}t) + c_2 \sin(\sqrt{1-\zeta^2}t)], & \zeta < 1. \end{cases} \quad (\text{D.10})$$

Here, ζ is a short form for $\beta/2$, and c_1 and c_2 are arbitrary constants. That is, the solution (D.10) is not unique.

To make the solution unique, we must determine c_1 and c_2 . This is done by specifying the state of the system at some point of time, say $t = 0$. In the present type of mathematical problem we must specify S and dS/dt . We allow the spring to be stretched an amount S_0 at $t = 0$. Moreover, we assume that there is no ongoing increase or decrease in the stretch at $t = 0$, which means that $dS/dt = 0$. In view of (D.9), this condition implies that the velocity of the box is that of the plate, and if the latter is at rest, the box is also at rest initially. The conditions at $t = 0$ are called *initial conditions*:

$$S(0) = S_0, \quad \frac{dS}{dt}(0) = 0. \quad (\text{D.11})$$

These two conditions provide two equations for the two unknown constants c_1 and c_2 . Without the initial conditions two things happen: (i) there are infinitely many solutions to the problem, and (ii) the computational algorithm in a program cannot start.

Also when $w \neq 0$ one can find solutions $S(t)$ of (D.8) in terms of mathematical expressions, but only for some very specific choices of $w(t)$ functions. With a program we can compute the solution $S(t)$ for any “reasonable” $w(t)$ by a quite simple method. The method gives only an approximate solution, but the approximation can usually be made as good as desired. This powerful solution method is described below.

D.1.4 Derivation of the Algorithm

To solve (D.8) on a computer, we do two things:

1. We calculate the solution at some discrete time points $t = t_i = i\Delta t$, $i = 0, 1, 2, \dots, N$.
2. We replace the derivatives by finite differences, which are approximate expressions for the derivatives.

The first and second derivatives can be approximated by³

$$\frac{dS}{dt}(t_i) \approx \frac{S(t_{i+1}) - S(t_{i-1}))}{2\Delta t}, \quad (\text{D.12})$$

$$\frac{d^2S}{dt^2}(t_i) \approx \frac{S(t_{i+1}) - 2S(t_i) + S(t_{i-1}))}{\Delta t^2}. \quad (\text{D.13})$$

It is common to save some writing by introducing S_i as a short form for $S(t_i)$. The formulas then read

$$\frac{dS}{dt}(t_i) \approx \frac{S_{i+1} - S_{i-1}}{2\Delta t}, \quad (\text{D.14})$$

$$\frac{d^2S}{dt^2}(t_i) \approx \frac{S_{i+1} - 2S_i + S_{i-1}}{\Delta t^2}. \quad (\text{D.15})$$

Let (D.8) be valid at a point of time t_i :

$$m \frac{d^2S}{dt^2}(t_i) + \beta \frac{dS}{dt}(t_i) + kS(t_i) = m \frac{d^2w}{dt^2}(t_i) + mg. \quad (\text{D.16})$$

We now insert (D.14) and (D.15) in (D.16) (observe that we can approximate d^2w/dt^2 in the same way as we approximate d^2S/dt^2):

$$m \frac{S_{i+1} - 2S_i + S_{i-1}}{\Delta t^2} + \beta \frac{S_{i+1} - S_{i-1}}{2\Delta t} + kS_i = m \frac{w_{i+1} - 2w_i + w_{i-1}}{\Delta t^2} + mg. \quad (\text{D.17})$$

The computational algorithm starts with knowing S_0 , then S_1 is computed, then S_2 , and so on. Therefore, in (D.17) we can assume that S_i and S_{i-1} are already computed, and that S_{i+1} is the new unknown to calculate. Let us as usual put the unknown terms on the left-hand side (and multiply by Δt^2):

$$mS_{i+1} + \gamma S_{i+1} = 2mS_i - mS_{i-1} + \gamma S_{i-1} - \Delta t^2 kS_i + m(w_{i+1} - 2w_i + w_{i-1}) + \Delta t^2 mg, \quad (\text{D.18})$$

where we have introduced the short form $\gamma = \frac{1}{2}\beta\Delta t$ to save space. Equation (D.18) can easily be solved for S_{i+1} :

$$S_{i+1} = (m + \gamma)^{-1} (2mS_i - mS_{i-1} + \gamma\Delta t S_{i-1} - \Delta t^2 kS_i + m(w_{i+1} - 2w_i + w_{i-1}) + \Delta t^2 mg). \quad (\text{D.19})$$

One fundamental problem arises when we try to start the computations. We know S_0 and want to apply (D.19) for $i = 0$ to calculate S_1 .

³ See Appendices B and C for derivations of such formulas.

However, (D.19) involves S_{i-1} , that is, S_{-1} , which is an unknown value at a point of time *before* we compute the motion. The initial conditions come to rescue here. Since $dS/dt = 0$ at $t = 0$ (or $i = 0$), we can approximate this condition as

$$\frac{S_1 - S_{-1}}{2\Delta t} = 0 \Rightarrow S_{-1} = S_1. \quad (\text{D.20})$$

Inserting this relation in (D.19) when $i = 0$ gives a special formula for S_1 (or S_{i+1} with $i = 0$, if we want):

$$S_{i+1} = \frac{1}{2m} (2mS_i - \Delta t^2 kS_i + m(w_{i+1} - 2w_i + w_{i-1}) + \Delta t^2 mg). \quad (\text{D.21})$$

Remember that $i = 0$ in this formula. The overall algorithm is summarized below:

1. Initialize S_0 from initial condition
2. Use (D.21) to compute S_{i+1} for $i = 0$
3. For $i = 0, 1, 2, \dots, N - 1$, use (D.19) to compute S_{i+1}

D.2 Program Development and Testing

D.2.1 Implementation

The aim now is to implement the algorithm on page 644 in a Python program. There are naturally two parts of the program, one where we read input data such as L , m , and $w(t)$, and one part where we run the computational algorithm. Let us write a function for each part.

The set of input data to the program consists of the mathematical symbols

- m (the mass of the box)
- b (the height of the box)
- L (the length of the unstretched spring)
- β (coefficient for the damping force)
- k (coefficient for the spring force)
- Δt (the time step between each S_i calculation)
- N (the number of computed time steps)
- S_0 (the initial stretch of the spring)
- $w(t)$ (the vertical displacement of the plate)
- g (acceleration of gravity)

We make a function `init_prms` for initializing these input parameters from option-value pairs on the command line. That is, the user provides pairs like `-m 2` and `-dt 0.1` (for Δt). The `argparse` module from Chapter 4.2.4 can be used for this purpose. We supply default values for all parameters as arguments to the `init_prms` function. The func-

tion returns all these parameters with the changes that the user has specified on the command line. The w parameter is given as a string expression (called `w_formula` below), and the `StringFunction` tool from Chapter 4.1.4 can be used to turn the formula into a working Python function. An algorithmic sketch of the tasks in the `init_prms` function can be expressed by some pseudo Python code:

```
def init_prms(m, b, L, k, beta, S0, dt, g, w_formula, N):
    import argparse
    parser = argparse.ArgumentParser()
    parser.add_argument('--m', '--mass',
                        type=float, default=m)
    parser.add_argument('--b', '--boxheight',
                        type=float, default=b)
    ...
    args = parser.parse_args()

    from scitools.StringFunction import StringFunction
    w = StringFunction(args.w, independent_variables='t')
    return args.m, args.b, args.L, args.k, args.beta, \
        args.S0, args.dt, args.g, w, args.N
```

With such a sketch as a start, we can complete the indicated code and arrive at a working function for specifying input parameters to the mathematical model:

```
def init_prms(m, b, L, k, beta, S0, dt, g, w_formula, N):
    import argparse
    parser = argparse.ArgumentParser()
    parser.add_argument('--m', '--mass',
                        type=float, default=m)
    parser.add_argument('--b', '--boxheight',
                        type=float, default=b)
    parser.add_argument('--L', '--spring-length',
                        type=float, default=L)
    parser.add_argument('--k', '--spring-stiffness',
                        type=float, default=k)
    parser.add_argument('--beta=', '--spring-damping',
                        type=float, default=beta)
    parser.add_argument('--S0', '--initial-position',
                        type=float, default=S0)
    parser.add_argument('--dt', '--timestep',
                        type=float, default=dt)
    parser.add_argument('--g', '--gravity',
                        type=float, default=g)
    parser.add_argument('--w', type=float, default=w)
    parser.add_argument('--N', type=int, default=N)
    args = parser.parse_args()

    from scitools.StringFunction import StringFunction
    w = StringFunction(args.w, independent_variables='t')
    return args.m, args.b, args.L, args.k, args.beta, \
        args.S0, args.dt, args.g, w, args.N
```

You may wonder why we specify g (gravity) since this is a known constant, but it is useful to turn off the gravity force to test the program. Just imagine the oscillations take place in the horizontal direction – the mathematical model is the same, but $F_g = 0$, which we can obtain in our program by setting the input parameter g to zero.

The computational algorithm is quite easy to implement, as there is a quite direct translation of the mathematical algorithm in Appendix D.1.2 to valid Python code. The S_i values can be stored in a list or array with indices going from 0 to N . To allow readers to follow the code here without yet having digested Chapter 5, we use a plain list. The function for computing S_i reads

```
def solve(m, k, beta, S0, dt, g, w, N):
    S = [0.0]*(N+1) # output list
    gamma = beta*dt/2.0 # short form
    t = 0
    S[0] = S0
    # Special formula for first time step
    i = 0
    S[i+1] = (1/(2.0*m))*(2*m*S[i] - dt**2*k*S[i] +
        m*(w(t+dt) - 2*w(t) + w(t-dt))) + dt**2*m*g)
    t = dt

    for i in range(1,N):
        S[i+1] = (1/(m + gamma))*(2*m*S[i] - m*S[i-1] +
            gamma*dt*S[i-1] - dt**2*k*S[i] +
            m*(w(t+dt) - 2*w(t) + w(t-dt)))
            + dt**2*m*g)
        t += dt
    return S
```

The primary challenge in coding the algorithm is to set the index i and the time t right. Recall that in the updating formula for $S[i+1]$ at time $t+dt$, the time on the right-hand side shall be the time at time step i , so the $t+=dt$ update must come after $S[i+1]$ is computed. The same is important in the special formula for the first time step as well.

A main program will typically first set some default values of the 10 input parameters, then call `init_prms` to let the user adjust the default values, and then call `solve` to compute the S_i values:

```
# Default values
from math import pi
m = 1; b = 2; L = 10; k = 1; beta = 0; S0 = 1;
dt = 2*pi/40; g = 9.81; w_formula = '0'; N = 80;

m, b, L, k, beta, S0, dt, g, w, N = \
    init_prms(m, b, L, k, beta, S0, dt, g, w_formula, N)
S = solve(m, k, beta, S0, dt, g, w, N)
```

So, what shall we do with the solution S ? We can write out the values of this list, but the numbers do not give an immediate feeling for how the box moves. It will be better to graphically illustrate the $S(t)$ function, or even better, the $Y(t)$ function. This is straightforward with the techniques from Chapter 5 and is treated in Appendix D.3. In Chapter 9.4, we develop a drawing tool for drawing figures like Figure D.1. By drawing the box, string, and plate at every time level we compute S_i , we can use this tool to make a moving figure that illustrates the dynamics of the oscilla-

tions. Already now you can play around with a program doing that (`box_spring_figure_anim.py`).

D.2.2 Callback Functionality

It would be nice to make some graphics of the system while the computations take place, not only after the S list is ready. The user must then put some relevant statements in between the statements in the algorithm. However, such modifications will depend on what type of analysis the user wants to do. It is a bad idea to mix user-specific statements with general statements in a general algorithm. We therefore let the user provide a function that the algorithm can call after each S_i value is computed. This is commonly called a *callback* function (because a general function calls back to the user's program to do a user-specific task). To this callback function we send three key quantities: the S list, the point of time (t), and the time step number ($i + 1$), so that the user's code gets access to these important data.

If we just want to print the solution to the screen, the callback function can be as simple as

```
def print_S(S, t, step):
    print't=%.2f S[%d]=%+g' % (t, step, S[step])
```

In the `solve` function we take the callback function as a keyword argument `user_action`. The default value can be an empty function, which we can define separately:

```
def empty_func(S, time, time_step_no):
    return None

def solve(m, k, beta, S0, dt, g, w, N,
          user_action=empty_func):
    ...
```

However, it is quicker to just use a lambda function (see Chapter 3.1.11):

```
def solve(m, k, beta, S0, dt, g, w, N,
          user_action=lambda S, time, time_step_no: None):
```

The new `solve` function has a call to `user_action` each time a new S value has been computed:

```
def solve(m, k, beta, S0, dt, g, w, N,
          user_action=lambda S, time, time_step_no: None):
    """Calculate N steps forward. Return list S."""
    S = [0.0]*(N+1) # output list
    gamma = beta*dt/2.0 # short form
    t = 0
    S[0] = S0
```

```

user_action(S, t, 0)
# Special formula for first time step
i = 0
S[i+1] = (1/(2.0*m))*(2*m*S[i] - dt**2*k*S[i] +
                m*(w(t+dt) - 2*w(t) + w(t-dt))) + dt**2*m*g)
t = dt
user_action(S, t, i+1)

# Time loop
for i in range(1,N):
    S[i+1] = (1/(m + gamma))*(2*m*S[i] - m*S[i-1] +
                                gamma*dt*S[i-1] - dt**2*k*S[i] +
                                m*(w(t+dt) - 2*w(t) + w(t-dt)))
                + dt**2*m*g)
    t += dt
    user_action(S, t, i+1)

return S

```

The two last arguments to `user_action` must be carefully set: these should be time value and index for the most recently computed `S` value.

D.2.3 Making a Module

The `init_prms` and `solve` functions can now be combined with many different types of main programs and `user_action` functions. It is therefore preferable to have the general `init_prms` and `solve` functions in a module `box_spring` and import these functions in more user-specific programs. Making a module out of `init_prms` and `solve` is, according to Chapter 4.5, quite trivial as we just need to put the functions in a file `box_spring.py`.

It is always a good habit to include a test block in module files. To make the test block small, we place the statements in a separate function `_test` and just call `_test` in the test block. The initial underscore in the name `_test` prevents this function from being imported by a `from box_spring import *` statement. Our test here simply prints solution at each time level. The following code snippet is then added to the module file to include a test block:

```

def _test():
    def print_S(S, t, step):
        print 't=%.2f S[%d]=%+g' % (t, step, S[step])

    # Default values
    from math import pi
    m = 1; b = 2; L = 10; k = 1; beta = 0; S0 = 1;
    dt = 2*pi/40; g = 9.81; w_formula = '0'; N = 80;

    m, b, L, k, beta, S0, dt, g, w, N = \
        init_prms(m, b, L, k, beta, S0, dt, g, w_formula, N)
    S = solve(m, k, beta, S0, dt, g, w, N,
              user_action=print_S)

if __name__ == '__main__':
    _test()

```

D.2.4 Verification

To check that the program works correctly, we need a series of problems where the solution is known. These test cases must be specified by someone with a good physical and mathematical understanding of the problem being solved. We already have a solution formula (D.10) that we can compare the computations with, and more tests can be made in the case $w \neq 0$ as well.

However, before we even think of checking the program against the formula (D.10), we should perform some much simpler tests. The simplest test is to see what happens if we do nothing with the system. This solution is of course not very exciting – the box is at rest, but it is in fact exciting to see if our program reproduces the boring solution. Many bugs in the program can be found this way! So, let us run the program `box_spring.py` with `-S0 0` as the only command-line argument. The output reads

```
t=0.00 S[0]=+0
t=0.16 S[1]=+0.121026
t=0.31 S[2]=+0.481118
t=0.47 S[3]=+1.07139
t=0.63 S[4]=+1.87728
t=0.79 S[5]=+2.8789
t=0.94 S[6]=+4.05154
t=1.10 S[7]=+5.36626
...
```

Something happens! All `S[1]`, `S[2]`, and so forth should be zero. What is the error?

There are two directions to follow now: we can either visualize the solution to understand more of what the computed $S(t)$ function looks like (perhaps this explains what is wrong), or we can dive into the algorithm and compute `S[1]` by hand to understand why it does not become zero. Let us follow both paths.

First we print out all terms on the right-hand side of the statement that computes `S[1]`. All terms except the last one ($\Delta t^2 mg$) are zero. The gravity term causes the spring to be stretched downward, which causes oscillations. We can see this from the governing equation (D.8) too: If there is no motion, $S(t) = 0$, the derivatives are zero (and $w = 0$ is default in the program), and then we are left with

$$kS = mg \quad \Rightarrow \quad S = \frac{m}{k}g. \quad (\text{D.22})$$

This result means that if the box is at rest, the spring is stretched (which is reasonable!). Either we have to start with $S(0) = \frac{m}{k}g$ in the equilibrium position, or we have to turn off the gravity force by setting `-g 0` on the command line. Setting either `-S0 0 -g 0` or `-S0 9.81` shows that the whole `S` list contains either zeros or 9.81 values (recall that $m = k = 1$ so $S_0 = g$). This constant solution is correct, and the coding looks promising.

We can also plot the solution using the program `box_spring_plot`:

Terminal

```
box_spring_plot.py --S0 0 --N 200
```

Figure D.2 shows the function $Y(t)$ for this case where the initial stretch is zero, but gravity is causing a motion. With some mathematical analysis of this problem we can establish that the solution is correct. We have that $m = k = 1$ and $w = \beta = 0$, which implies that the governing equation is

$$\frac{d^2 S}{dt^2} + S = g, \quad S(0) = 0, \quad dS/dt(0) = 0.$$

Without the g term this equation is simple enough to be solved by basic techniques you can find in most introductory books on differential equations. Let us therefore get rid of the g term by a little trick: we introduce a new variable $T = S - g$, and by inserting $S = T + g$ in the equation, the g is gone:

$$\frac{d^2 T}{dt^2} + T = 0, \quad T(0) = -g, \quad \frac{dT}{dt}(0) = 0. \quad (\text{D.23})$$

This equation is of a very well-known type and the solution reads $T(t) = -g \cos t$, which means that $S(t) = g(1 - \cos t)$ and

$$Y(t) = -L - g(1 - \cos t) - \frac{b}{2}.$$

With $L = 10$, $g \approx 10$, and $b = 2$ we get oscillations around $y \approx 21$ with a period of 2π and a start value $Y(0) = -L - b/2 = 11$. A rough visual inspection of the plot shows that this looks right. A more thorough analysis would be to make a test of the numerical values in a new callback function (the program is found in `box_spring_test1.py`):

```
from box_spring import init_prms, solve
from math import cos

def exact_S_solution(t):
    return g*(1 - cos(t))

def check_S(S, t, step):
    error = exact_S_solution(t) - S[step]
    print 't=%.2f S[%d]=%+g error=%g' % (t, step, S[step], error)

# Fixed values for a test
from math import pi
m = 1; b = 2; L = 10; k = 1; beta = 0; S0 = 0
dt = 2*pi/40; g = 9.81; N = 200

def w(t):
    return 0

S = solve(m, k, beta, S0, dt, g, w, N, user_action=check_S)
```

The output from this program shows increasing errors with time, up as large values as 0.3. The difficulty is to judge whether this is the error one must expect because the program computes an approximate solution, or if this error points to a bug in the program – or a wrong mathematical formula.

From these sessions on program testing you will probably realize that verification of mathematical software is challenging. In particular, the design of the test problems and the interpretation of the numerical output require quite some experience with the interplay between physics (or another application discipline), mathematics, and programming.

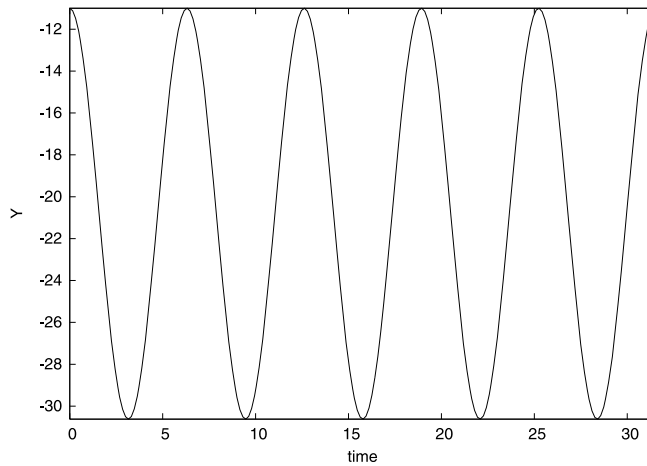

Fig. D.2 Positions $Y(t)$ of an oscillating box with $m = k = 1$, $w = \beta = 0$, $g = 9.81$, $L = 10$, and $b = 2$.

D.3 Visualization

The purpose of this section is to add graphics to the oscillating system application developed in Appendix D.2. Recall that the function `solve` solves the problem and returns a list `S` with indices from 0 to `N`. Our aim is to plot this list and various physical quantities computed from it.

D.3.1 Simultaneous Computation and Plotting

The `solve` function makes a call back to the user's code through a callback function (the `user_action` argument to `solve`) at each time level. The callback function has three arguments: `S`, the time, and the current time step number. Now we want the callback function to plot the position $Y(t)$ of the box during the computations. In principle this is easy, but `S` is longer than we want to plot, because `S` is allocated

for the whole time simulation while the `user_action` function is called at time levels where only the indices in `S` up to the current time level have been computed (the rest of the elements in `S` are zero). We must therefore use a sublist of `S`, from time zero and up to the current time. The callback function we send to `solve` as the `user_action` argument can then be written like this:

```
def plot_S(S, t, step):
    if step == 0:      # nothing to plot yet
        return None

    tcoor = linspace(0, t, step+1)
    S = array(S[:len(tcoor)])
    Y = w(tcoor) - L - S - b/2.
    plot(tcoor, Y)
```

Note that `L`, `dt`, `b`, and `w` must be global variables in the user's main program.

The major problem with the `plot_S` function shown is that the `w(tcoor)` evaluation does not work. The reason is that `w` is a `StringFunction` object, and according to Chapter 5.5.1, `StringFunction` objects do not work with array arguments unless we call their `vectorize` function once. We therefore need to do a

```
w.vectorize(globals())
```

before calling `solve` (which calls `plot_S` repeatedly). Here is the main program with this important statement:

```
from box_spring import init_prms, solve
from scitools.std import *

# Default values
m = 1; b = 2; L = 10; k = 1; beta = 0; S0 = 1;
dt = 2*pi/40; g = 9.81; w_formula = '0'; N = 200;

m, b, L, k, beta, S0, dt, g, w, N = \
    init_prms(m, b, L, k, beta, S0, dt, g, w_formula, N)

w.vectorize(globals())

S = solve(m, k, beta, S0, dt, g, w, N, user_action=plot_S)
```

Now the `plot_S` function works fine. You can try the program out by running

```
Terminal
```

```
box_spring_plot_v1.py
```

Fixing Axes. Both the t and the y axes adapt to the solution array in every plot. The adaptation of the y is okay since it is difficult to predict the future minimum and maximum values of the solution, and hence it is most natural to just adapt the y axis to the computed Y points so far in the simulation. However, the t axis should be fixed throughout

the simulation, and this is easy since we know the start and end times. The relevant plot call now becomes⁴

```
plot(tcoor, Y,
      axis=[0, N*dt, min(Y), max(Y)],
      xlabel='time', ylabel='Y')
```

At the end of the simulation it can be nice to make a hardcopy of the last plot command performed in the `plot_S` function. We then just call

```
savefig('tmp_Y.eps')
```

after the `solve` function is finished.

In the beginning of the simulation it is convenient to skip plotting for a number of steps until there are some interesting points to visualize and to use for computing the axis extent. We also suggest to apply the recipe at the end of Chapter 5.5.1 to vectorize `w`. More precisely, we use `w.vectorize` in general, but turn to numpy's `vectorize` feature only if the string formula contains an inline `if-else` test (to avoid requiring users to use `where` to vectorize the string expressions). One reason for paying attention to `if-else` tests in the `w` formula is that sudden movements of the plate are of interest, and this gives rise to step functions and strings like `'1 if t>0 else 0'`. A main program with all these features is listed next.

```
from box_spring import init_prms, solve
from scitools.std import *

def plot_S(S, t, step):
    first_plot_step = 10          # skip the first steps
    if step < first_plot_step:
        return

    tcoor = linspace(0, t, step+1) # t = dt*step
    S = array(S[:len(tcoor)])
    Y = w(tcoor) - L - S - b/2.0   # (w, L, b are global vars.)

    plot(tcoor, Y,
          axis=[0, N*dt, min(Y), max(Y)],
          xlabel='time', ylabel='Y')

# Default values
m = 1; b = 2; L = 10; k = 1; beta = 0; S0 = 1
dt = 2*pi/40; g = 9.81; w_formula = '0'; N = 200

m, b, L, k, beta, S0, dt, g, w, N = \
    init_prms(m, b, L, k, beta, S0, dt, g, w_formula, N)

# Vectorize the StringFunction w
w_formula = str(w) # keep this to see if w=0 later
if ' else ' in w_formula:
    w = vectorize(w)      # general vectorization
else:
    w.vectorize(globals()) # more efficient (when no if)
```

⁴ Note that the final time is $T = N\Delta t$.

```
S = solve(m, k, beta, S0, dt, g, w, N, user_action=plot_S)
# First make a hardcopy of the last plot of Y
hardcopy('tmp_Y.eps')
```

D.3.2 Some Applications

What if we suddenly, right after $t = 0$, move the plate upward from $y = 0$ to $y = 1$? This will set the system in motion, and the task is to find out what the motion looks like.

There is no initial stretch in the spring, so the initial condition becomes $S_0 = 0$. We turn off gravity for simplicity and try a $w = 1$ function since the plate has the position $y = w = 1$ for $t > 0$:

```
Terminal
```

```
box_spring_plot.py --w'1' --S 0 --g 0
```

Nothing happens. The reason is that we specify $w(t) = 1$, but in the equation only d^2w/dt^2 has an effect and this quantity is zero. What we need to specify is a step function: $w = 0$ for $t \leq 0$ and $w = 1$ for $t > 0$. In Python such a function can be specified as a string expression `'1 if t>0 else 0'`. With a step function we obtain the right initial jump of the plate:

```
Terminal
```

```
box_spring_plot.py --w'1 if t > 0 else 0' \
--S0 0 --g 0 --N 1000 --beta 0.1
```

Figure D.3 displays the solution. We see that the damping parameter has the effect of reducing the amplitude of $Y(t)$, and the reduction looks exponential, which is in accordance with the exact solution (D.10) (although this formula is not valid in the present case because $w \neq 0$ – but one gets the same exponential reduction even in this case). The box is initially located in $Y = 0 - (10 + 0) - 2/2 = -11$. During the first time step we get a stretch $S = 0.5$ and the plate jumps up to $y = 1$ so the box jumps to $Y = 1 - (10 + 0.5) - 2/2 = -10.5$. In Figure D.3b we see that the box starts correctly out and jumps upwards, as expected.

More exciting motions of the box can be obtained by moving the plate back and forth in time, see for instance Figure D.4 on page 661.

D.3.3 Remark on Choosing Δt

If you run the `box_spring_plot.py` program with a large `-dt` argument (for Δt), strange things may happen. Try `-dt 2 -N 20` as command-line arguments and observe that Y jumps up and down in a saw tooth

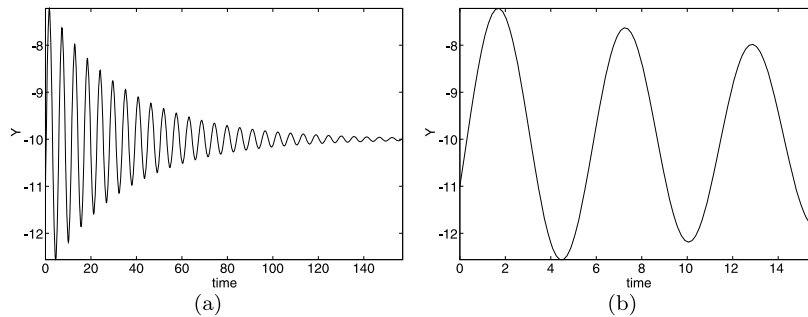

Fig. D.3 Plot of the position of an oscillating box where the end point of the spring ($w(t)$) is given a sudden movement at $t = 0$. Other parameters are $m = k = 1$, $\beta = 0.1$, $g = 0$, $S_0 = 0$. (a) 1000 time steps; (b) 100 steps for magnifying the first oscillation cycles.

fashion so we clearly have too large time steps. Then try `-dt 2.1 -N 20` and observe that Y takes on very large values (10^5). This highly non-physical result points to an error in the program. However, the problem is not in the program, but in the numerical method used to solve (D.8). This method becomes unstable and hence useless if Δt is larger than a critical value. We shall not dig further into such problems, but just notice that mathematical models on a computer must be used with care, and that a serious user of simulation programs must understand how the mathematical methods work in detail and what their limitations are.

D.3.4 Comparing Several Quantities in Subplots

So far we have plotted Y , but there are other interesting quantities to look at, e.g., S , w , the spring force, and the damping force. The spring force and S are proportional, so only one of these is necessary to plot. Also, the damping force is relevant only if $\beta \neq 0$, and w is only relevant if the string formula is different from the default value '0'.

All the mentioned additional plots can be placed in the same figure for comparison. To this end, we apply the `subfigure` command in Easyviz and create a row of individual plots. How many plots we have depends on the values of `str(w)` and `beta`. The relevant code snippet for creating the additional plots is given below and appears after the part of the main program shown above.

```
# Make plots of several additional interesting quantities
tcoor = linspace(0, tstop, N+1)
S = array(S)

plots = 2          # number of rows of plots
if beta != 0:
    plots += 1
if w_formula != '0':
    plots += 1
```

```

# Position Y(t)
plot_row = 1
subplot(plots, 1, plot_row)
Y = w(tcoor) - L - S - b/2.0
plot(tcoor, Y, xlabel='time', ylabel='Y')

# Spring force (and S)
plot_row += 1
subplot(plots, 1, plot_row)
Fs = k*S
plot(tcoor, Fs, xlabel='time', ylabel='spring force')

# Friction force
if beta != 0:
    plot_row += 1
    subplot(plots, 1, plot_row)
    Fd = beta*diff(S) # diff is in numpy
    # len(diff(S)) = len(S)-1 so we use tcoor[:-1]:
    plot(tcoor[:-1], Fd, xlabel='time', ylabel='damping force')

# Excitation
if w_formula != '0':
    plot_row += 1
    subplot(plots, 1, plot_row)
    w_array = w(tcoor)
    plot(tcoor, w_array, xlabel='time', ylabel='w(t)')

savefig('tmp.eps') # save this multi-axis plot in a file

```

Figure D.4 displays what the resulting plot looks like for a test case with an oscillating plate (w). The command for this run is

```

Terminal
box_spring_plot.py --S0 0 --w'2*(cos(8*t)-1)' \
--N 600 --dt 0.05236

```

The rapid oscillations of the plate require us to use a smaller Δt and more steps (larger N).

D.3.5 Comparing Approximate and Exact Solutions

To illustrate multiple curves in the same plot and animations we turn to a slightly different program. The task now is to visually investigate how the accuracy of the computations depends on the Δt parameter. The smaller Δt is, the more accurate the solution S is. To look into this topic, we need a test problem with known solution. Setting $m = k = 1$ and $w = 0 = \beta = 0$ implies the exact solution $S(t) = g(1 - \cos t)$ (see Appendix D.2.4). The `box_spring_test1.py` program from Appendix D.2.4 can easily be extended to plot the calculated solution together with the exact solution. We drop the `user_action` callback function and just make the plot after having the complete solution `S` returned from the `solve` function:

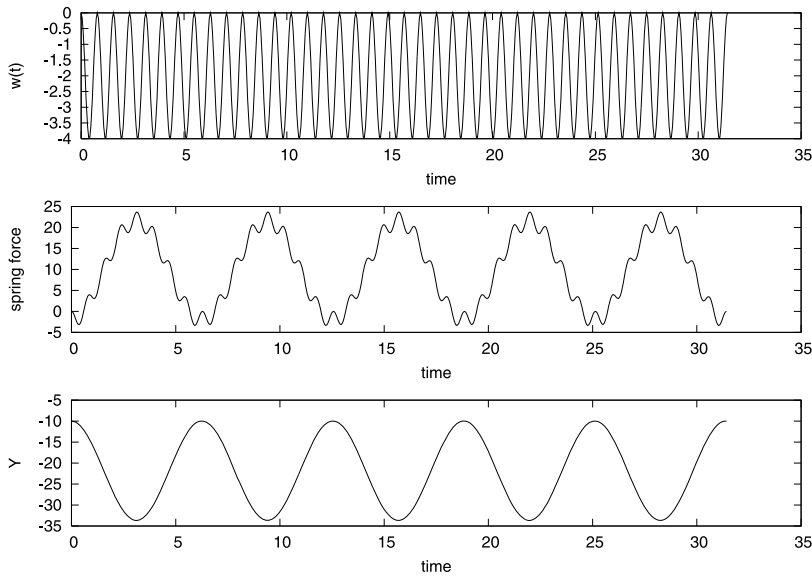

Fig. D.4 Plot of the plate position $w(t)$, the spring force (proportional to $S(t)$), and the position $Y(t)$ for a test problem where $w(t) = 2(\cos(8t) - 1)$, $\beta = g = 0$, $m = k = 1$, $S_0 = 0$, $\Delta t = 0.5236$, and $N = 600$.

```
tcoor = linspace(0, N*dt, len(S))
exact = exact_S_solution(tcoor)
plot(tcoor, S, 'r', tcoor, exact, 'b',
     xlabel='time', ylabel='S',
     legend=('computed S(t)', 'exact S(t)'),
     savefig='tmp_S.eps')
```

The two curves tend to lie upon each other, so to get some more insight into the details of the error, we plot the error itself, in a separate plot window:

```
figure() # new plot window
S = array(S) # turn list into NumPy array for computations
error = exact - S
plot(tcoor, error, xlabel='time', ylabel='error',
     savefig='tmp_error.eps')
```

The error increases in time as the plot in Figure D.5a clearly shows.

D.3.6 Evolution of the Error as Δt Decreases

Finally, we want to investigate how the error curve evolves as the time step Δt decreases. In a loop we halve Δt in each pass, solve the problem, compute the error, and plot the error curve. From the finite difference formulas involved in the computational algorithm, we can expect that the error is of order Δt^2 . That is, if Δt is halved, the error should be reduced by $1/4$.

The resulting plot of error curves is not very informative because the error reduces too quickly (by several orders of magnitude). A better plot

is obtained by taking the logarithm of the error. Since an error curve may contain positive and negative elements, we take the absolute value of the error before taking the logarithm. We also note that S_0 is always correct, so it is necessary to leave out the initial value of the error array to avoid the logarithm of zero.

The ideas of the previous two paragraphs can be summarized in a Python code snippet:

```
figure()      # new plot window
dt = 2*pi/10
tstop = 8*pi # 4 periods
N = int(tstop/dt)
for i in range(6):
    dt /= 2.0
    N *= 2
    S = solve(m, k, beta, S0, dt, g, w, N)
    S = array(S)
    tcoor = linspace(0, tstop, len(S))
    exact = exact_S_solution(tcoor)
    abserror = abs(exact - S)
    # Drop abserror[0] since it is always zero and causes
    # problems for the log function:
    logerror = log10(abserror[1:])

    plot(tcoor[1:], logerror, 'r', xlabel='time',
         ylabel='log10(abs(error))')
    hold('on')
savefig('tmp_errors.eps')
```

The resulting plot is shown in Figure D.5b.

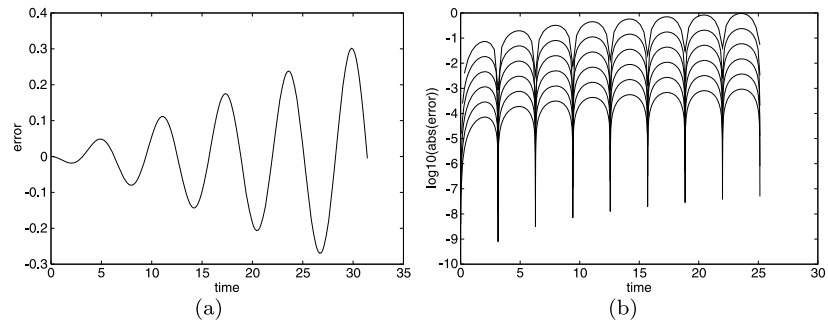

Fig. D.5 Error plots for a test problem involving an oscillating system: (a) the error as a function of time; (b) the logarithm of the absolute value of the error as a function of time, where Δt is reduced by one half from one curve to the next one below.

Visually, it seems to be a constant distance between the curves in Figure D.5b. Let d denote this difference and let E_i be the absolute error curve associated with Δt in the i -th pass in the loop. What we plot is $\log_{10} E_i$. The difference between two curves is then $D_{i+1} = \log_{10} E_i - \log_{10} E_{i+1} = \log_{10}(E_i/E_{i+1})$. If this difference is roughly 0.5 as we see from Figure D.5b, we have

$$\log_{10} \frac{E_i}{E_{i+1}} = d = 0.5 \Rightarrow E_{i+1} = \frac{1}{3.16} E_i.$$

That is, the error is reduced, but not by the theoretically expected factor 4. Let us investigate this topic in more detail by plotting D_{i+1} .

We make a loop as in the last code snippet, but store the `logerror` array from the previous pass in the loop (E_i) in a variable `logerror_prev` such that we can compute the difference D_{i+1} as

```
logerror_diff = logerror_prev - logerror
```

There are two problems to be aware of now in this array subtraction: (i) the `logerror_prev` array is not defined before the second pass in the loop (when `i` is one or greater), and (ii) `logerror_prev` and `logerror` have different lengths since `logerror` has twice as many time intervals as `logerror_prev`. Numerical Python does not know how to compute this difference unless the arrays have the same length. We therefore need to use every two elements in `logerror`:

```
logerror_diff = logerror_prev - logerror[::2]
```

An additional problem now arises because the set of time coordinates, `tcoor`, in the current pass of the loop also has twice as many intervals so we need to plot `logerror_diff` against `tcoor[::2]`.

The complete code snippet for plotting differences between the logarithm of the absolute value of the errors now becomes

```
figure()
dt = 2*pi/10
tstop = 8*pi # 4 periods
N = int(tstop/dt)
for i in range(6):
    dt /= 2.0
    N *= 2
    S = solve(m, k, beta, S0, dt, g, w, N)
    S = array(S)
    tcoor = linspace(0, tstop, len(S))
    exact = exact_S_solution(tcoor)
    abserror = abs(exact - S)
    logerror = log10(abserror[1:])
    if i > 0:
        logerror_diff = logerror_prev - logerror[::2]
        plot(tcoor[1::2], logerror_diff, 'r', xlabel='time',
             ylabel='difference in log10(abs(error))')
        hold('on')
        meandiff = mean(logerror_diff)
        print 'average log10(abs(error)) difference:', meandiff
    logerror_prev = logerror
savefig('tmp_errors_diff.eps')
```

Figure D.6 shows the result. We clearly see that the differences between the curves in Figure D.5b are almost the same even if Δt is reduced by several orders of magnitude.

In the loop we also print out the average value of the difference curves in Figure D.6:

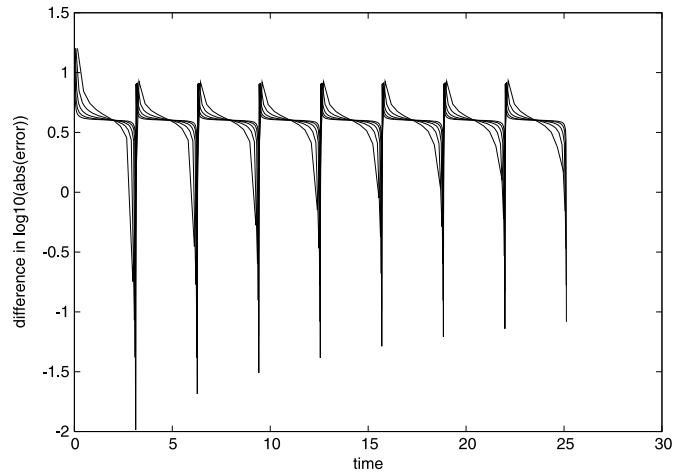

Fig. D.6 Differences between the curves in Figure D.5b.

```

average log10(abs(error)) difference: 0.558702094666
average log10(abs(error)) difference: 0.56541814902
average log10(abs(error)) difference: 0.576489014172
average log10(abs(error)) difference: 0.585704362507
average log10(abs(error)) difference: 0.592109360025

```

These values are “quite constant”. Let us use 0.57 as an representative value and see what it implies. Roughly speaking, we can then say that

$$\log_{10} E_i - \log_{10} E_{i+1} = 0.57.$$

Collecting the two first terms and applying the exponential function 10^x on both sides we get that

$$E_{i+1} = \frac{1}{3.7} E_i.$$

This error reduction when Δt is decreased is not quite as good as we would theoretically expect ($1/4$), but it is close. The purpose of this brief analysis is primarily to show how errors can be explored by plotting, and how we can take advantage of array computing to produce various quantities of interest in a problem. A more thorough investigation of how the error depends on Δt would use time integrals of the error instead of the complete error curves.

Again we mention that the complete problem analyzed in this appendix is challenging to understand because of its mix of physics, mathematics, and programming. In real life, however, problem solving in science and industry involve multi-disciplinary projects where people with different competence work together. As a scientific programmer you must then be able to fully understand what to program and how to verify the results. This is a requirement in the current summarizing example too. You have to accept that your programming problem is buried in a lot of physical and mathematical details.

Having said this, we expect that most readers of this book also gain a background in physics and mathematics so that the present summarizing example can be understood in complete detail, at least at some later stage.

D.4 Exercises

Exercise D.1. *Use a w function with a step.*

Set up a problem with the `box_spring_plot.py` program where the initial stretch in the spring is 1 and there is no gravity force. Between $t = 20$ and $t = 30$ we move the plate suddenly from 0 to 2 and back again:

$$w(t) = \begin{cases} 2, & 20 < t < 30, \\ 0, & \text{otherwise} \end{cases}$$

Run this problem and view the solution. \diamond

Exercise D.2. *Make a callback function in Exercise D.1.*

Doing Exercise D.1 shows that the Y position increases significantly in magnitude when the plate “jumps” upward and back again at $t = 20$ and $t = 30$, respectively. Make a program where you import from the `box_spring` module and provide a callback function that checks if $Y < 9$ and then aborts the program. Name of program file: `box_spring_Ycrit.py`. \diamond

Exercise D.3. *Improve input to the simulation program.*

The oscillating system in Appendix D.1 has an equilibrium position $S = mg/k$, see (D.22) on page 653. A natural case is to let the box start at rest in this position and move the plate to induce oscillations. We must then prescribe $S_0 = mg/k$ on the command line, but the numerical value depends on the values of m and g that we might also give in the command line. However, it is possible to specify `-S0 m*g/k` on the command line if we in the `init_prms` function first let `S0` be a string in the `elif` test and then, after the `for` loop, execute `S0 = eval(S0)`. At that point, `m` and `k` are read from the command line so that `eval` will work on `'m*g/k'`, or any other expression involving data from the command. Implement this idea.

A first test problem is to start from rest in the equilibrium position $S(0) = mg/k$ and give the plate a sudden upward change in position from $y = 0$ to $y = 1$. That is,

$$w(t) = \begin{cases} 0, & t \leq 0, \\ 1, & t > 0 \end{cases}$$

You should get oscillations around the displaced equilibrium position $Y = w - L - S_0 = -9 - 2g$. Name of program file: `box_spring2.py`. \diamond

Appendices C and D give a brief introduction differential equations, with a focus on a few specific equations and programs that are tailored to these equations. The present appendix views differential equations from a more abstract point of view, which allows us to formulate numerical methods and create general software that are applicable to a large family of widely different problems from physics, biology, finance, and numerous other disciplines. More specifically, the abstract view is motivated by the slogan *implement once, apply anywhere*. We have in fact met this principle several places in the book: differentiation ($f''(x)$) in Chapters 3.1.9 and 7.3.2, integration ($\int_a^b f(x)dx$) in Chapters 3.4.2 and 7.3.3, and root finding ($f(x) = 0$) in Chapter 4.6.2 and Appendix A.1.10. In all of the referred implementations, we work with a *general function* $f(x)$ so that any problem can be solved by the same piece of code as long as we can define the problem in terms of a function $f(x)$. This is an excellent demonstration of the power of mathematics, and this abstract view of problems in terms of some $f(x)$ is especially powerful in numerical methods and programming. Now we shall formulate differential equations on the abstract form $u' = f(u, t)$ and create software that can solve any equation for which the $f(u, t)$ is given.

Before studying the present appendix, the reader should have some familiarity with differential equations at the level of Appendix C. Appendix D can also be advantageous to read, although this is not strictly required. Fundamental programming skills corresponding to Chapters 1–5 are required for the basic material in this appendix. However, we also use classes to a large extent, which demands familiarity with the concepts in Chapter 7. The material on object-oriented programming in Appendix E.2.5 requires good knowledge of class hierarchies from Chapter 9.

All computer codes associated with this appendix is found in `src/ode2`.

E.1 Scalar Ordinary Differential Equations

We shall in this appendix work with ordinary differential equations (ODEs) written on the abstract form

$$u'(t) = f(u(t), t). \quad (\text{E.1})$$

There is an infinite number of solutions to such an equation, so to make the solution $u(t)$ unique, we must also specify an initial condition

$$u(0) = U_0. \quad (\text{E.2})$$

Given $f(u, t)$ and U_0 , our task is to compute $u(t)$.

A first sight, (E.1) is only a first-order differential equation, since only u' and not higher-order derivatives like u'' are present in the equation. However, equations with higher-order derivatives can also be written on the abstract form (E.1) by introducing auxiliary variables and interpreting u and f as vector functions. This rewrite of the original equation leads to a system of first-order differential equations and will be treated in Appendix E.2. The bottom line is that a very large family of differential equations can be written as (E.1). Forthcoming examples will provide evidence.

We shall first assume that $u(t)$ is a *scalar function*, meaning that it has one number as value, which can be represented as a `float` object in Python. We then refer to (E.1) as a *scalar differential equation*. The counterpart *vector function* means that u is a vector of scalar functions and the equation is known as a *system of ODEs* (also known as a *vector ODE*). The value of a vector function is a list or array in a program, not more complicated than explained in Chapter 5.

E.1.1 Examples on Right-Hand-Side Functions

To write a specific differential equation on the form (E.1) we need to identify what the f function is. Say the equation reads

$$y^2 y' = x, \quad y(0) = Y,$$

with $y(x)$ as the unknown function. First, we need to introduce u and t as new symbols: $u = y$, $t = x$. This gives the equivalent equation $u^2 u' = t$ and the initial condition $u(0) = Y$. Second, the quantity u' must be isolated on the left-hand side of the equation in order to bring the equation on the form (E.1). Dividing by u^2 gives

$$u' = tu^{-2}.$$

This fits the form (E.1), and the $f(u, t)$ function is simply the formula involving u and t on the right-hand side:

$$f(u, t) = tu^{-2}.$$

The t parameter is very often absent on the right-hand side such that f involves u only.

Below is a set of commonly arising scalar differential equations and their corresponding f functions.

1. Exponential growth of money or populations:

$$u' = \alpha u, \tag{E.3}$$

where $\alpha > 0$ is a given constant expressing the growth rate of u .

$$f(u, t) = \alpha u. \tag{E.4}$$

2. Logistic growth of a population under limited resources:

$$u' = \alpha u \left(1 - \frac{u}{R}\right), \tag{E.5}$$

where $\alpha > 0$ is the initial growth rate and R is the maximum possible value of u .

$$f(u, t) = \alpha u \left(1 - \frac{u}{R}\right). \tag{E.6}$$

3. Radioactive decay of a substance:

$$u' = -au, \tag{E.7}$$

where $a > 0$ is the rate of decay of u .

$$f(u, t) = -au. \tag{E.8}$$

4. Body falling in a fluid:

$$u' + b|u|u = g, \tag{E.9}$$

where $b > 0$ models the fluid resistance, g is the acceleration of gravity, and u is the body's velocity (see Exercise E.11 on page 709).

$$f(u, t) = -b|u|u + g. \tag{E.10}$$

5. Newton's law of cooling:

$$u' = -h(u - s), \tag{E.11}$$

where u is the temperature of a body, $h > 0$ is a proportionality

constant, normally to be estimated from experiments, and s is the temperature of the surroundings.

$$f(u, t) = -h(u - s). \quad (\text{E.12})$$

E.1.2 The Forward Euler Scheme

Our task now is to define numerical methods for solving equations of the form (E.1). The simplest such method is the Forward Euler scheme. Equation (E.1) is to be solved for $t \in (0, T]$, and we seek the solution u at discrete time points $t_i = i\Delta t$, $i = 1, 2, \dots, n$. Clearly, $t_n = n\Delta t = T$, determining the number of points n as $T/\Delta t$. The corresponding values $u(t_i)$ are often abbreviated as u_i , just for notational simplicity.

Equation (E.1) is to be fulfilled at all time points $t \in (0, T]$. However, when we solve (E.1) numerically, we only require the equation to be satisfied at the discrete time points t_1, t_2, \dots, t_n . That is,

$$u'(t_k) = f(u(t_k), t_k),$$

for $k = 1, \dots, n$. The fundamental idea of the Forward Euler scheme is to approximate $u'(t_k)$ by a one-sided, forward difference:

$$u'(t_k) \approx \frac{u(t_{k+1}) - u(t_k)}{\Delta t} = \frac{u_{k+1} - u_k}{\Delta t}.$$

This removes the derivative and leaves us with the equation

$$\frac{u_{k+1} - u_k}{\Delta t} = f(u_k, t_k).$$

We assume that u_k is already computed, so that the only unknown in this equation is u_{k+1} , which we can solve for:

$$u_{k+1} = u_k + \Delta t f(u_k, t_k). \quad (\text{E.13})$$

This is the Forward Euler scheme for a scalar first-order differential equation $u' = f(u, t)$.

Equation (E.13) has a recursive nature. We start with the initial condition, $u_0 = U_0$, and compute u_1 as

$$u_1 = u_0 + \Delta t f(u_0, t_0).$$

Then we can continue with

$$u_2 = u_1 + \Delta t f(u_1, t_1),$$

and then with u_3 and so forth. This recursive nature of the method also demonstrates that we *must* have an initial condition – otherwise the method cannot start.

E.1.3 Function Implementation

The next task is to write a general piece of code that implements the Forward Euler scheme (E.13). The complete original (continuous) mathematical problem is stated as

$$u' = f(u, t), \quad t \in (0, T], \quad u(0) = U_0, \quad (\text{E.14})$$

while the discrete numerical problem reads

$$u_{k+1} = u_k + \Delta t f(u_k, t_k), \quad t_k = k\Delta t, \quad k = 1, \dots, n, \quad n = T/\Delta t, \quad u_0 = U_0. \quad (\text{E.15})$$

We see that the input data to the numerical problem consist of f , U_0 , T , and Δt or n . The output consists of u_1, u_2, \dots, u_n and the corresponding set of time points t_1, t_2, \dots, t_n .

Let us implement The Forward Euler scheme in a function `ForwardEuler` that takes f , U_0 , T , and n as input, and that returns u_0, \dots, u_n and t_0, \dots, t_n :

```
def ForwardEuler(f, U0, T, n):
    """Solve u'=f(u,t), u(0)=U0, with n steps until t=T."""
    import numpy as np
    t = np.zeros(n+1)
    u = np.zeros(n+1) # u[k] is the solution at time t[k]
    u[0] = U0
    t[0] = 0
    dt = T/float(n)
    for k in range(n):
        t[k+1] = t[k] + dt
        u[k+1] = u[k] + dt*f(u[k], t[k])
    return u, t
```

Note the close correspondence between the implementation and the mathematical specification of the problem to be solved. The argument f to the `ForwardEuler` function must be a Python function $f(u, t)$ implementing the $f(u, t)$ function in the differential equation (i.e., f is the definition of the equation to be solved). For example, we may solve $u' = u$ for $t \in (0, 3)$, with $u(0) = 1$, and $\Delta t = 0.1$ by the following code utilizing the `ForwardEuler` function:

```
def f(u, t):
    return u

u, t = ForwardEuler(f, U0=1, T=3, n=30)
```

With the u and t arrays we can easily plot the solution or perform data analysis on the numbers.

E.1.4 Verifying the Implementation

The simplest, yet very effective, way to verify the implementation is to compute a couple of time steps by hand, say u_1 and u_2 :

$$u_1 = 1 + 0.1 \cdot 1 = 1.1, \quad u_2 = 1.1 + 0.1 \cdot 1.1 = 1.21.$$

These values are to be compared with the numbers produced by the code:

```
u, t = ForwardEuler(f, U0=1, T=0.2, n=2)
print u
```

Another effective way to verify the code, is to find a problem that can be solved exactly by the numerical method we use. That is, we seek a problem where we do not have to deal with mathematical approximation errors when comparing the exact solution with that produced by the program. It turns out that if the solution $u(t)$ is linear in t , the Forward Euler method will reproduce this solution exactly. Therefore, we choose $u(t) = at + U_0$, with (e.g.) $a = 0.2$ and $U_0 = 3$. The corresponding f is the derivative of u , i.e., $f(u, t) = a$. This is obviously a very simple right-hand side without any u or t . However, we can make f more complicated by adding something that is zero, e.g., some expression with $u - (at + U_0)$, say $(u - (at + U_0))^4$, so that

$$f(u, t) = a + (u - (at + U_0))^4. \quad (\text{E.16})$$

We implement our special f and the exact solution in two functions `f1` and `u_solution_f1`, and write out the numerical and exact solutions for comparison:

```
def f1(u, t):
    return 0.2 + (u - u_solution_f1(t))**4

def u_solution_f1(t):
    return 0.2*t + 3

u, t = ForwardEuler(f1, U0=3, T=3, n=5)
print 'Numerical:', u
print 'Exact:     ', u_solution_f1(t)
```

The output becomes

```
Numerical: [ 3.    3.12  3.24  3.36  3.48  3.6 ]
Exact:     [ 3.    3.12  3.24  3.36  3.48  3.6 ]
```

showing that the code works as it should in this example.

E.1.5 From Discrete to Continuous Solution

The numerical solution of an ODE is a *discrete function* in the sense that we only know the function values u_0, u_1, \dots, u_N at some discrete points t_0, t_1, \dots, t_N in time. What if we want to know u between two computed points? For example, what is u between t_i and t_{i+1} , say at the midpoint $t = t_i + \frac{1}{2}\Delta t$? One can use *interpolation* techniques to find this value u . The simplest interpolation technique is to assume that u

varies linearly on each time interval. On the interval $[t_i, t_{i+1}]$ the linear variation of u becomes

$$u(t) = u_i + \frac{u_{i+1} - u_i}{t_{i+1} - t_i}(t - t_i).$$

We can then evaluate, e.g., $u(t_i + \frac{1}{2}\Delta t)$ from this formula and show that it becomes $(u_i + u_{i+1})/2$.

The function `scitools.std.wrap2callable` can automatically convert a discrete function to a continuous function:

```
from scitools.std import wrap2callable
u_cont = wrap2callable((t, u))
```

From the arrays `t` and `u`, `wrap2callable` constructs a continuous function based on linear interpolation. The result `u_cont` is a Python function that we can evaluate for any value of its argument `t`:

```
dt = t[i+1] - t[i]
t = t[i] + 0.5*dt
value = u_cont(t)
```

In general, the `wrap2callable` function is handy when you have computed some discrete function and you want to evaluate this discrete function at any point.

E.1.6 Switching Numerical Method

There are numerous alternative numerical methods for solving (E.13). One of the simplest is Heun's method:

$$u_* = u_k + \Delta t f(u_k, t_k), \quad (\text{E.17})$$

$$u_{k+1} = u_k + \frac{1}{2}\Delta t f(u_k, t_k) + \frac{1}{2}\Delta t f(u_*, t_{k+1}). \quad (\text{E.18})$$

This scheme is easily implemented in the `ForwardEuler` function by replacing the Forward Euler formula

```
u[k+1] = u[k] + dt*f(u[k], t[k])
```

by (E.17) and (E.18):

```
u_star = u[k] + dt*f(u[k], t[k])
u[k+1] = u[k] + 0.5*dt*f(u[k], t[k]) + 0.5*dt*f(u_star, t[k+1])
```

We can, especially if `f` is expensive to calculate, eliminate a call `f(u[k], t[k])` by introducing an auxiliary variable:

```
f_k = f(u[k], t[k])
u_star = u[k] + dt*f_k
u[k+1] = u[k] + 0.5*dt*f_k + 0.5*dt*f(u_star, t[k+1])
```

E.1.7 Class Implementation

As an alternative to the general `ForwardEuler` function in Appendix E.1.3, we shall now implement the numerical method in a class. This requires, of course, familiarity with the class concept from Chapter 7.

Class Wrapping of a Function. Let us start with simply wrapping the `ForwardEuler` function in a class `ForwardEuler_v1` (the postfix `_v1` indicates that this is the very first class version). That is, we take the code in the `ForwardEuler` function and distribute it among methods in a class.

The constructor can store the input data of the problem and initialize data structures, while a `solve` method can perform the time stepping procedure:

```
import numpy as np

class ForwardEuler_v1:
    def __init__(self, f, U0, T, n):
        self.f, self.U0, self.T, self.n = f, dt, U0, T, n
        self.dt = T/float(n)
        self.u = np.zeros(n+1)
        self.t = np.zeros(n+1)

    def solve(self):
        """Compute solution for 0 <= t <= T."""
        self.u[0] = float(self.U0)
        self.t[0] = float(0)

        for k in range(self.n):
            self.k = k
            self.t[k+1] = self.t[k] + self.dt
            self.u[k+1] = self.advance()
        return self.u, self.t

    def advance(self):
        """Advance the solution one time step."""
        u, dt, f, k, t = \
            self.u, self.dt, self.f, self.k, self.t

        u_new = u[k] + dt*f(u[k], t[k])
        return u_new
```

Note that we have introduced a third class method, `advance`, which isolates the numerical scheme. The motivation is that, by observation, the constructor and the `solve` method are completely general as they remain unaltered if we change the numerical method (at least this is true for a wide class of numerical methods). The only difference between various numerical schemes is the updating formula. It is therefore a good programming habit to isolate the updating formula so that another scheme can be implemented by just replacing the `advance` method – without touching any other parts of the class.

Also note that we in the `advance` method “strip off” the `self` prefix by introducing local symbols with exactly the same names as in the mathematical specification of the numerical method. This is important if we want a one-to-one correspondence between the mathematics and the implementation.

Application of the class goes as follows, here for the model problem $u' = u$, $u(0) = 1$:

```
def u_exp():
    def f(u, t):
        return u

    solver = ForwardEuler_v1(f, U0=1, T=3, n=15)
    u, t = solver.solve()

u_exp()
```

Switching Numerical Method. Implementing, for example, Heun’s method (E.17)–(E.18) is a matter of replacing the `advance` method by

```
def advance(self):
    """Advance the solution one time step."""
    u, dt, f, k, t = \
        self.u, self.dt, self.f, self.k, self.t

    u_star = u[k] + dt*f(u[k], t[k])
    u_new = u[k] + \
        0.5*dt*f(u[k], t[k]) + 0.5*dt*f(u_star, t[k+1])
    return u_new
```

Checking input data is always a good habit, and in the present class the constructor may test that the `f` argument is indeed an object that can be called as a function (cf. page 361):

```
if not callable(f):
    raise TypeError('f is %s, not a function' % type(f))
```

A More Flexible Class. Say we solve $u' = f(u, t)$ from $t = 0$ to $t = T_1$. We can continue the solution for $t > T_1$ simply by restarting the whole procedure with initial conditions at $t = T_1$. Hence, the implementation should allow several consecutive solve steps.

Another fact is that the time step Δt does not need to be constant. Allowing small Δt in regions where u changes rapidly and letting Δt be larger in areas where u is slowly varying, is an attractive solution strategy. The Forward Euler method can be reformulated for a variable time step size $t_{k+1} - t_k$:

$$u_{k+1} = u_k + (t_{k+1} - t_k)f(u_k, t_k). \quad (\text{E.19})$$

Similarly, Heun’s method and many other methods can be formulated with a variable step size simply by replacing Δt with $t_{k+1} - t_k$. It then

makes sense for the user to provide a list or array with time points for which a solution is sought: t_0, t_1, \dots, t_n . The solve method can accept such a set of points.

The mentioned extensions lead to a modified class:

```
class ForwardEuler:
    def __init__(self, f):
        if not callable(f):
            raise TypeError('f is %s, not a function' % type(f))
        self.f = f

    def set_initial_condition(self, U0):
        self.U0 = float(U0)

    def solve(self, time_points):
        """Compute u for t values in time_points list."""
        self.t = np.asarray(time_points)
        self.u = np.zeros(len(time_points))
        # Assume self.t[0] corresponds to self.U0
        self.u[0] = self.U0

        for k in range(len(self.t)-1):
            self.k = k
            self.u[k+1] = self.advance()
        return self.u, self.t

    def advance(self):
        """Advance the solution one time step."""
        u, f, k, t = self.u, self.f, self.k, self.t
        dt = t[k+1] - t[k]
        u_new = u[k] + dt*f(u[k], t[k])
        return u_new
```

Here is a verification of the implementation, first integrating the equation corresponding to the f in (E.16) for the time points 0, 0.4, 1, 1.2, and then continuing the solution process for $t_1 = 1.4$ and $t_2 = 1.5$ with $t_0 = 1.2$ as initial point:

```
def _verify_f1_ForwardEuler():
    U0 = 3
    solver = ForwardEuler(_f1)
    solver.set_initial_condition(U0)
    t = [0, 0.4, 1, 1.2]
    u1, t1 = solver.solve(t)
    # Continue with a new time interval
    solver.set_initial_condition(u1[-1])
    t = [1.2, 1.4, 1.5]
    u2, t2 = solver.solve(t)
    u = np.concatenate((u1, u2))
    t = np.concatenate((t1, t2))
    u_exact = _u_solution_f1(t)
    print 'time values:', t
    print 'Numerical: ', u
    print 'Exact: ', u_exact
```

The output is exactly what we would expect:

```
time values: [ 0.  0.4  1.  1.2  1.2  1.4  1.5]
Numerical:  [ 3.  3.08  3.2  3.24  3.24  3.28  3.3 ]
Exact:      [ 3.  3.08  3.2  3.24  3.24  3.28  3.3 ]
```

E.1.8 Example: Logistic Growth

A more exciting application is to solve the logistic equation (C.23),

$$u'(t) = \alpha u(t) \left(1 - \frac{u(t)}{R} \right).$$

The $f(u, t)$ function is simply the right-hand side of this ODE.

Implementing this problem with the aid of the `ForwardEuler` function from Appendix E.1.3 is left as an exercise for the reader, while we here explain how to utilize class `ForwardEuler` from Appendix E.1.7. Also the right-hand-side function $f(u, t)$ will be implemented as a class, because it contains the parameters α and R . We may store the initial condition as part of this class and have a `__str__` method for pretty print of the formula for the right-hand-side of the logistic equation.

This problem class can then be expressed as

```
class Logistic:
    """Problem class for a logistic ODE."""
    def __init__(self, alpha, R, U0):
        self.alpha, self.R, self.U0 = alpha, float(R), U0

    def __call__(self, u, t):
        """Return f(u,t) for the logistic ODE."""
        return self.alpha*u*(1 - u/self.R)

    def __str__(self):
        """Return ODE and initial condition."""
        return "u'(t) = %g*u*(1 - u/%g)\nu(0)=%g" % \
            (self.alpha, self.R, self.U0)
```

Running a case with $\alpha = 0.2$, $R = 1$, $u(0) = 0.1$, and 400 equally spaced time points up to time $T = 40$, can be performed in the following function:

```
def logistic():
    problem = Logistic(alpha=0.2, R=1, U0=0.1)
    T = 40
    solver = ForwardEuler(problem)
    solver.set_initial_condition(problem.U0)
    t = np.linspace(0, T, 401) # 400 intervals in [0,T]
    u, t = solver.solve(t)
```

A plot of u versus t is shown in Figure E.1.

The `ForwardEuler` class is further developed in Appendix E.2, where the code is extended to other numerical methods and also systems of ODEs.

E.2 Systems of Ordinary Differential Equations

The software developed so far in this appendix targets scalar ODEs of the form $u' = f(u, t)$ with initial condition $u(0) = U_0$. Our goal

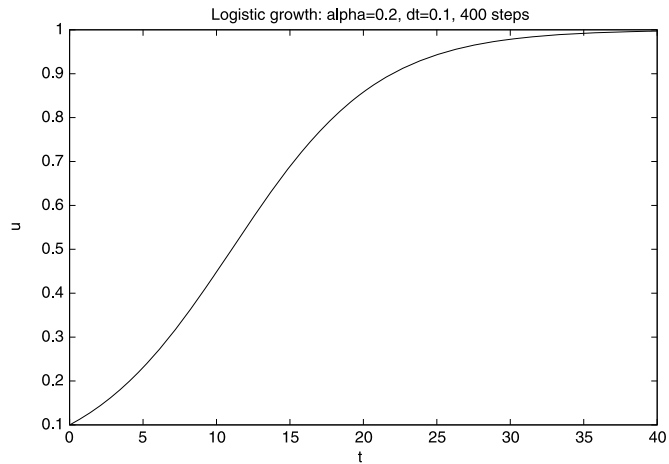

Fig. E.1 Plot of the solution of the ODE problem $u' = 0.2u(1 - u)$, $u(0) = 0.1$.

now is to build a flexible toolbox for solving scalar ODEs as well as systems of ODEs. That is, we want the same code to work both for systems and scalar equations. Moreover, the user should be able to easily switch between different numerical methods, with a minimum of coding. Also, the developer of the tools should be able to include a new numerical method with a minimum of coding. All these requirements can be met by utilizing object-oriented programming from Chapter 9. Recommended background material consists of Chapters 9.1–9.3.

E.2.1 Mathematical Problem

A scalar ODE involves the single equation

$$u'(t) = f(u(t), t)$$

with a single function $u(t)$ as unknown, while a system of ODEs involves n scalar ODEs and consequently n unknown functions. Let us denote the unknown functions in the system by $u^{(i)}(t)$, with i as a counter, $i = 0, \dots, m - 1$. The system of n ODEs can then be written in the following abstract form:

$$\frac{du^{(0)}}{dt} = f^{(0)}(u^{(0)}, u^{(1)}, \dots, u^{(m-1)}, t), \quad (\text{E.20})$$

$$\vdots$$

$$\frac{du^{(i)}}{dt} = f^{(i)}(u^{(0)}, u^{(1)}, \dots, u^{(m-1)}, t), \quad (\text{E.21})$$

$$\vdots$$

$$\frac{du^{(m-1)}}{dt} = f^{(m-1)}(u^{(0)}, u^{(1)}, \dots, u^{(m-1)}, t). \quad (\text{E.22})$$

In addition, we need n initial conditions for the n unknown functions:

$$u^{(i)}(0) = U_0^{(i)}, \quad i = 0, \dots, m-1. \quad (\text{E.23})$$

Instead of writing out each equation as in (E.20)–(E.22), mathematicians like to collect the individual functions $u^{(0)}, u^{(1)}, \dots, u^{(m-1)}$ in a vector

$$u = (u^{(0)}, u^{(1)}, \dots, u^{(m-1)}).$$

The different right-hand-side functions $f^{(0)}, f^{(1)}, \dots, f^{(m-1)}$ in (E.20)–(E.22) can also be collected in a vector

$$f = (f^{(0)}, f^{(1)}, \dots, f^{(m-1)}).$$

Similarly, we put the initial conditions also in a vector

$$U_0 = (U_0^{(0)}, U_0^{(1)}, \dots, U_0^{(m-1)}).$$

With the vectors u , f , and U_0 , we can write the ODE system (E.20)–(E.22) with initial conditions (E.23) as

$$u' = f(u, t), \quad u(0) = U_0. \quad (\text{E.24})$$

This is exactly the same notation as we used for a scalar ODE (!). The power of mathematics is that abstractions can be generalized so that new problems look like the familiar ones, and very often methods carry over to the new problems in the new notation without any changes. This is true for numerical methods for ODEs too.

Let us apply the Forward Euler scheme to each of the ODEs in the system (E.20)–(E.22):

$$u_{k+1}^{(0)} = u_k^{(0)} + \Delta t f^{(0)}(u_k^{(0)}, u_k^{(1)}, \dots, u_k^{(m-1)}, t_k), \quad (\text{E.25})$$

$$\vdots$$

$$u_{k+1}^{(i)} = u_k^{(i)} + \Delta t f^{(i)}(u_k^{(0)}, u_k^{(1)}, \dots, u_k^{(m-1)}, t_k), \quad (\text{E.26})$$

$$\vdots$$

$$u_{k+1}^{(m-1)} = u_k^{(m-1)} + \Delta t f^{(m-1)}(u_k^{(0)}, u_k^{(1)}, \dots, u_k^{(m-1)}, t_k). \quad (\text{E.27})$$

Utilizing the vector notation, (E.25)–(E.27) can be compactly written as

$$u_{k+1} = u_k + \Delta t f(u_k, t_k), \quad (\text{E.28})$$

and this is again nothing but the formula we had for the Forward Euler scheme applied to a scalar ODE.

To summarize, the notation $u' = f(u, t)$, $u(0) = U_0$, is from now on used both for scalar ODEs and for systems of ODEs. In the former case, u and f are scalar functions, while in the latter case they are

vectors. This great flexibility carries over to programming too: we can develop code for $u' = f(u, t)$ that works for scalar ODEs and systems of ODEs, the only difference being that u and f correspond to `float` objects for scalar ODEs and to arrays for systems of ODEs.

Unless you are quite familiar with systems of ODEs and array arithmetics, it can be a good idea to just think about scalar ODEs and that $u(t)$ is a function of one variable when you read on. Later, you can come back and reread the text with systems of ODEs and $u(t)$ as a vector (array) in mind. The invisible difference between scalar ODEs and systems of ODEs is not only important for addressing *both* newcomers to ODEs and more experienced readers. The principle is very important for software development too: We can write code with scalar ODEs in mind and test this code. Afterwards, the code should also work immediately for systems and $u(t)$ as a vector of functions. This remarkable achievement is obtained by an elegant interplay between abstractions in mathematics and the functionality and syntax of the Python programming language.

E.2.2 Example of a System of ODEs

An oscillating spring-mass system can be governed by a second-order ODE (see (D.8) in Appendix D for derivation):

$$mu'' + \beta u' + ku = F(t), \quad u(0) = U_0, \quad u'(0) = 0. \quad (\text{E.29})$$

The parameters m , β , and k are known and $F(t)$ is a prescribed function. This second-order equation can be rewritten as two first-order equations by introducing two functions (see Appendix C.4),

$$u^{(0)}(t) = u(t), \quad u^{(1)}(t) = u'(t).$$

The unknowns are now the position $u^{(0)}(t)$ and the velocity $u^{(1)}(t)$. We can then create equations where the derivative of the two new primary unknowns $u^{(0)}$ and $u^{(1)}$ appear alone on the left-hand side:

$$\frac{d}{dt}u^{(0)}(t) = u^{(1)}(t), \quad (\text{E.30})$$

$$\frac{d}{dt}u^{(1)}(t) = m^{-1}(F(t) - \beta u^{(1)} - ku^{(0)}). \quad (\text{E.31})$$

We write this system as $u'(t) = f(u, t)$ where now u and f are vectors, here of length two:

$$u(t) = (u^{(0)}(t), u^{(1)}(t))$$

$$f(t, u) = (u^{(1)}, m^{-1}(F(t) - \beta u^{(1)} - ku^{(0)})). \quad (\text{E.32})$$

Note that the vector $u(t)$ is different from the quantity u in (E.29)! There are, in fact, several interpretation of the symbol u , depending

on the context: the exact solution u of (E.29), the numerical solution u of (E.29), the vector u in a rewrite of (E.29) as a first-order ODE system, and the array u in the software, holding the numerical values of $u(t) = (u^{(0)}(t), u^{(1)}(t))$.

E.2.3 From Scalar ODE Code to Systems

Let us have a look at how the software from Appendices E.1.3–E.1.7 changes if we try to apply it to systems of ODEs.

Function Implementation. We start with the `ForwardEuler` function listed on page 671 and the specific system from Appendix E.2.2. The right-hand-side function $f(u, t)$ must now return the vector in (E.32), here as a NumPy array:

```
def f(u, t):
    return np.array([u[1], 1./m*(F(t) - beta*u[1] - k*u[0])])
```

Note that u is an array with two components, holding the values of the two unknown functions $u^{(0)}(t)$ and $u^{(1)}(t)$ at time t .

The initial conditions can also be specified as an array

```
U0 = np.array([0.1, 0])
```

What happens if we just send these f and $U0$ objects to the `ForwardEuler` function?

To answer the question, we must examine each statement inside the function to see if the Python operations are still valid. But of greater importance, we must check that right mathematics is carried out. The first failure occurs with the statement

```
u = np.zeros(n+1) # u[k] is the solution at time t[k]
```

Now, u should be an array of arrays, since the solution at each time level is an array. The length of $U0$ gives information on how many equations and unknowns there are in the system. An updated code might be

```
if isinstance(U0, (float,int)):
    u = np.zeros(n+1)
else:
    neq = len(U0)
    u = np.zeros((n+1,neq))
```

Fortunately, the rest of the code now works regardless of whether u is a one- or two-dimensional array. In the former case, $u[k+1] = u[k] + \dots$ involves computations with `float` objects only, while in the latter case, $u[k+1]$ picks out “row” $k + 1$ in u , which is the array with the two unknown values at time t_{k+1} : $u^{(0)}(t_{k+1})$ and $u^{(1)}(t_{k+1})$. The statement $u[k+1] = u[k] + \dots$ then involves array arithmetic with arrays of length two in this specific example.

Allowing Lists. The specification of `f` and `U0` using arrays is not as readable as a plain list specification:

```
def f(u, t):
    return [u[1], 1./m*(F(t) - beta*u[1] - k*u[0])]
U0 = [0.1, 0]
```

Users would probably prefer the list syntax. With a little adjustment inside the modified `ForwardEuler` function we can allow lists, tuples, or arrays for `U0` and as return objects from `f`. With `U0` we just do

```
U0 = np.asarray(U0)
```

since `np.asarray` will just return `U0` if it already is an array and otherwise copy the data to an array.

With `f` the situation is a bit more demanding. The array operation `dt*f(u[k], t[k])` will not work unless `f` really returns an array (since lists or tuples cannot be multiplied by a scalar `dt`). A trick is to wrap a function around the user-provided right-hand-side function:

```
def ForwardEuler(f_user, dt, U0, T):
    def f(u, t):
        return np.asarray(f_user(u, t))
    ...
```

Now, `dt*f(u[k], t[k])` will call `f`, which calls the user's `f_user` and turns whatever is returned from that function into a NumPy array. A more compact syntax arises from using a lambda function (see Chapter 3.1.11):

```
def ForwardEuler(f, dt, U0, T):
    f = lambda u, t: np.asarray(f(u, t))
    ...
```

Here we have also gotten rid of `f_user` and simply overwrite the user-provided `f` function by a new function `f` which ensures that the evaluation of the right-hand side results in an array.

Class Implementation. Proceeding with class `ForwardEuler` from Appendix E.1.7, we make observations similar to those above. The trick with the lambda function is introduced in the constructor, and distinguishing between scalar and vector ODEs is necessary where `self.U0` and `self.u` are created. The complete class looks as follows (see the file `session.py` for real code with applications):

```
class ForwardEuler:
    """
    Class for solving a scalar or vector ODE,
        du/dt = f(u, t)
    by the ForwardEuler solver.
```

```

Class attributes:
t: array of time values
u: array of solution values (at time points t)
k: step number of the most recently computed solution
f: callable object implementing f(u, t)
"""
def __init__(self, f):
    if not callable(f):
        raise TypeError('f is %s, not a function' % type(f))
    self.f = lambda u, t: np.asarray(f(u, t))

def set_initial_condition(self, U0):
    if isinstance(U0, (float,int)): # scalar ODE
        self.neq = 1
    else: # system of ODEs
        U0 = np.asarray(U0)
        self.neq = U0.size
    self.U0 = U0

def solve(self, time_points):
    """Compute u for t values in time_points list."""
    self.t = np.asarray(time_points)
    n = self.t.size
    if self.neq == 1: # scalar ODEs
        self.u = np.zeros(n)
    else: # systems of ODEs
        self.u = np.zeros((n,self.neq))

    # Assume self.t[0] corresponds to self.U0
    self.u[0] = self.U0

    # Time loop
    for k in range(n-1):
        self.k = k
        self.u[k+1] = self.advance()
    return self.u, self.t

def advance(self):
    """Advance the solution one time step."""
    u, f, k, t = self.u, self.f, self.k, self.t
    dt = t[k+1] - t[k]
    u_new = u[k] + dt*f(u[k], t[k])
    return u_new

```

The application code for the equation $u'' + u = 0$, $u(0) = 0$, $u'(0) = 1$, with solution $u(t) = \sin(t)$ and $u'(t) = \cos(t)$, reads

```

def f(u, t):
    return [u[1], -u[0]]

U0 = [0, 1]
solver = ForwardEuler(f)
solver.set_initial_condition(U0)
T = 12; n = 100
t = np.linspace(0, T, n+1)
u, t = solver.solve(t)
u0 = u[:,0]

```

Note that the computed u array is two-dimensional, where $u[k, i]$ holds $u^{(i)}(t_k)$. Hence, to grab all the values associated with $u^{(0)}$, we fix i as 0 and let the k index take on all its legal values: $u[:, 0]$. Then $u0$ refers to the piece of u where the discrete values $u^{(0)}(t_0), u^{(0)}(t_1), \dots, u^{(0)}(t_n)$ are stored.

E.2.4 Numerical Methods

Numerical methods for ODEs compute approximations u_k to the exact solution u at discrete time levels t_k , $k = 1, 2, 3, \dots$. Some of the simplest, but also most widely used methods for ODEs are listed below.

1. The Forward Euler method:

$$u_{k+1} = u_k + \Delta t f(u_k, t_k), \quad \Delta t = t_{k+1} - t_k. \quad (\text{E.33})$$

2. The Midpoint method:

$$u_{k+1} = u_{k-1} + 2\Delta t f(u_k, t_k), \quad 2\Delta t = t_{k+1} - t_{k-1} \quad (\text{E.34})$$

for $k = 1, 2, \dots$. The computation of u_1 involves u_{-1} , which is unknown, so for the first step we must use another method, for instance, (E.33).

3. Heun's method:

$$u_* = u_k + \Delta t f(u_k, t_k), \quad (\text{E.35})$$

$$u_{k+1} = u_k + \frac{1}{2}\Delta t f(u_k, t_k) + \frac{1}{2}\Delta t f(u_*, t_{k+1}), \quad (\text{E.36})$$

with $\Delta t = t_{k+1} - t_k$.

4. The 2nd-order Runge-Kutta method:

$$u_{k+1} = u_k + K_2 \quad (\text{E.37})$$

where

$$K_1 = \Delta t f(u_k, t_k), \quad (\text{E.38})$$

$$K_2 = \Delta t f\left(u_k + \frac{1}{2}K_1, t_k + \frac{1}{2}\Delta t\right), \quad (\text{E.39})$$

with $\Delta t = t_{k+1} - t_k$.

5. The 4th-order Runge-Kutta method:

$$u_{k+1} = u_k + \frac{1}{6}(K_1 + 2K_2 + 2K_3 + K_4), \quad (\text{E.40})$$

where

$$K_1 = \Delta t f(u_k, t_k), \quad (\text{E.41})$$

$$K_2 = \Delta t f\left(u_k + \frac{1}{2}K_1, t_k + \frac{1}{2}\Delta t\right), \quad (\text{E.42})$$

$$K_3 = \Delta t f\left(u_k + \frac{1}{2}K_2, t_k + \frac{1}{2}\Delta t\right), \quad (\text{E.43})$$

$$K_4 = \Delta t f(u_k + K_3, t_k + \Delta t), \quad (\text{E.44})$$

and $\Delta t = t_{k+1} - t_k$.

6. The 3rd-order Adams-Bashforth method:

$$u_{k+1} = u_k + \frac{\Delta t}{12} (23f(u_k, t_k) - 16f(u_{k-1}, t_{k-1}) + 5f(u_{k-2}, t_{k-2})), \quad (\text{E.45})$$

with Δt constant. To start the scheme, one can apply a 2nd-order Runge-Kutta method or Heun's method to compute u_1 and u_2 before (E.45) is applied for $k \geq 2$.

7. The Midpoint method with iterations:

$$v_q = u_k + \frac{1}{2} \Delta t (f(v_{q-1}, t_{k+1}) + f(u_k, t_k)), \quad (\text{E.46})$$

$$q = 1, \dots, N, \quad v_0 = u_k$$

$$u_{k+1} = v_N. \quad (\text{E.47})$$

At each time level, one runs the formula (E.46) N times, and the value v_N becomes u_{k+1} . Setting $N = 1$ recovers the Forward Euler scheme if f is independent of t , while $N = 2$ corresponds to Heun's method. We can either fix the value of N , or we can repeat (E.46) until the change in v_q is small, that is, until $|v_q - v_{q-1}| < \epsilon$, where ϵ is a small value. Fixing N is sufficient in this exercise.

8. The Backward Euler method:

$$u_{k+1} = u_k + \Delta t f(u_{k+1}, t_{k+1}), \quad \Delta t = t_{k+1} - t_k. \quad (\text{E.48})$$

If $f(u, t)$ is nonlinear in u , (E.48) constitutes a nonlinear equation in u_{k+1} , which must be solved by some method for nonlinear equations, say Newton's method (see Appendix E.2.6 for more details).

The methods above are valid both for scalar ODEs and for systems of ODEs. In the system case, the quantities u , u_k , u_{k+1} , f , K_1 , K_2 , etc., are vectors.

E.2.5 The ODE Solver Class Hierarchy

Appendix E.2.3 presents a class `ForwardEuler` for implementing the Forward Euler scheme (E.33) both for scalar ODEs and systems. Only the `advance` method should be necessary to change in order to implement other numerical methods. Copying the `ForwardEuler` class and editing just the `advance` method is considered bad programming practice, because we get two copies the general parts of class `ForwardEuler`. As we implement more schemes, we end up with a lot of copies of the same code. Correcting an error or improving the code in this general part then requires identical edits in several almost identical classes.

A good programming practice is to collect all the common code in a superclass. Subclasses can implement the `advance` method, but share

the constructor, the `set_initial_condition` method, and the `solve` method with the superclass.

The Superclass. We introduce class `ODESolver` as the superclass of various numerical methods for solving ODEs. Class `ODESolver` should provide all functionality that is common to all numerical methods for ODEs:

1. hold the solution $u(t)$ at discrete time points in an array `u`
2. hold the corresponding time values `t`
3. hold information about the $f(u, t)$ function, i.e., a callable Python object `f(u, t)`
4. hold the current time step number k in an attribute `k`
5. hold the initial condition U_0
6. implement the loop over all time steps

As already outlined in Appendix E.1.7, we implement the last point as two methods: `solve` for performing the time loop and `advance` for advancing the solution one time step. The latter method is empty in the superclass since the method is to be implemented by various subclasses for various numerical schemes.

A first version class `ODESolver` follows directly from class `ForwardEuler` in Appendix E.2.3, but letting `advance` be an empty method. However, there is one more extension which will be handy in some problems, namely a possibility for the user to terminate the time loop if the solution has certain properties. Throwing a ball yields an example: the simulation should be stopped when the ball hits the ground, instead of simulating an artificial movement down in the ground until the final time T is reached. To implement the requested feature, the user can provide a function `terminate(u, t, step_no)`, which returns `True` if the time loop is to be terminated. The arguments are the solution array `u`, the corresponding time points `t`, and the current time step number `step_no`. For example, if we want to solve an ODE until the solution is (close to) zero, we can supply the function

```
def terminate(u, t, step_no):
    eps = 1.0E-6          # small number
    if abs(u[step_no,0]) < eps: # close enough to zero?
        return True
    else:
        return False
```

The `terminate` function is an optional argument to the `solve` method. By default, we provide a function that always returns `False`.

The suggested code for the superclass `ODESolver` then takes the following form:

```
class ODESolver:
    def __init__(self, f):
        self.f = lambda u, t: np.asarray(f(u, t), float)
```



```

def advance(self):
    """Advance solution one time step."""
    raise NotImplementedError

def set_initial_condition(self, U0):
    if isinstance(U0, (float,int)): # scalar ODE
        self.neq = 1
        U0 = float(U0)
    else:
        # system of ODEs
        U0 = np.asarray(U0)
        self.neq = U0.size
    self.U0 = U0

def solve(self, time_points, terminate=None):
    if terminate is None:
        terminate = lambda u, t, step_no: False

    self.t = np.asarray(time_points)
    n = self.t.size
    if self.neq == 1: # scalar ODEs
        self.u = np.zeros(n)
    else:
        # systems of ODEs
        self.u = np.zeros((n,self.neq))

    # Assume that self.t[0] corresponds to self.U0
    self.u[0] = self.U0

    # Time loop
    for k in range(n-1):
        self.k = k
        self.u[k+1] = self.advance()
        if terminate(self.u, self.t, self.k+1):
            break # terminate loop over k
    return self.u[:k+2], self.t[:k+2]

```

Note that we return just the parts of `self.u` and `self.t` that have been filled with values (the rest are zeroes): all elements up to the one with index `k+1` are computed before `terminate` may return `True`. The corresponding slice of the array is then `:k+2` since the upper limit is not included in the slice. If `terminate` never returns `True` we simply have that `:k+1` is the entire array.

The Forward Euler Method. Subclasses implement specific numerical formulas for numerical solution of ODEs in the `advance` method. For the Forward Euler the formula is given by (E.33). All data we need for this formula are stored as attributes by the superclass. First we load these data into variables with shorter names, to avoid the lengthy `self` prefix and obtain a notation closer to the mathematics. Then we apply the formula (E.33), and finally we return the new value:

```

class ForwardEuler(ODESolver):
    def advance(self):
        u, f, k, t = self.u, self.f, self.k, self.t
        dt = t[k+1] - t[k]
        u_new = u[k] + dt*f(u[k], t[k])
        return u_new

```

Remark. When we extract attributes to local variables with short names, we should only use these local variables for reading values, not

setting values. For example, if we do a `k += 1` to update the time step counter, that increased value is not reflected in `self.k` (which is the “official” counter). On the other hand, changing a list *in-place*, say `u[k+1] = ...`, is reflected in `self.u`. Extracting class attributes in local variables is done for getting the code closer to the mathematics, but has a danger of introducing bugs that might be hard to track down.

The 4th-order Runge-Kutta Method. Below is an implementation of the 4th-order Runge-Kutta method (E.40):

```
class RungeKutta4(ODESolver):
    def advance(self):
        u, f, k, t = self.u, self.f, self.k, self.t
        dt = t[k+1] - t[k]
        dt2 = dt/2.0
        K1 = dt*f(u[k], t[k])
        K2 = dt*f(u[k] + 0.5*K1, t[k] + dt2)
        K3 = dt*f(u[k] + 0.5*K2, t[k] + dt2)
        K4 = dt*f(u[k] + K3, t[k] + dt)
        u_new = u[k] + (1/6.0)*(K1 + 2*K2 + 2*K3 + K4)
        return u_new
```

It is left as exercises to implement other numerical methods in the `ODESolver` class hierarchy. However, the Backward Euler method (E.48) requires a much more advanced implementation than the other methods so that particular method deserves its own section.

E.2.6 The Backward Euler Method

The Backward Euler scheme (E.48) leads in general to a *nonlinear* equation at a new time level, while all the other schemes listed in Appendix E.2.4 have a simple formula for the new u_{k+1} value. The nonlinear equation reads

$$u_{k+1} = u_k + \Delta t f(u_{k+1}, t_{k+1}).$$

For simplicity we assume that the ODE is scalar so the unknown u_{k+1} is a scalar. It might be easier to see that the equation for u_{k+1} is nonlinear if we rearrange the equation to

$$F(w) \equiv w - \Delta t f(w, t_{k+1}) - u_k = 0, \quad (\text{E.49})$$

where $w = u_{k+1}$. If now $f(u, t)$ is a nonlinear function of u , $F(w)$ will also be a nonlinear function of w .

To solve $F(w) = 0$ we can use the Bisection method from Chapter 4.6.2, Newton’s method from Appendix A.1.10, or the Secant method from Exercise A.14. Here we apply Newton’s method and the implementation given in `src/diffeq/Newton.py`. A disadvantage with Newton’s method is that we need the derivative of F with respect

to w , which requires the derivative $\partial f(w,t)/\partial w$. A quick solution is to use a numerical derivative, e.g., class `Derivative` from Chapter 7.3.2.

We make a subclass `BackwardEuler`. As we need to solve $F(w) = 0$ at every time step, we also need to implement the $F(w)$ function. This is conveniently done in a local function inside the `advance` method¹:

```
def advance(self):
    u, f, k, t = self.u, self.f, self.k, self.t

    def F(w):
        return w - dt*f(w, t[k+1]) - u[k]

    dFdw = Derivative(F)
    w_start = u[k] + dt*f(u[k], t[k]) # Forward Euler step
    u_new, n, F_value = Newton(F, w_start, dFdw, N=30)
    if n >= 30:
        print "Newton's failed to converge at t=%g "\
              "(%d iterations)" % (t, n)
    return u_new
```

The derivative dF/dw is computed numerically by a class `Derivative`, which is a slight modification of the similar class in Chapter 7.3.2, because we now want to use a more accurate, centered formula:

```
class Derivative:
    def __init__(self, f, h=1E-5):
        self.f = f
        self.h = float(h)

    def __call__(self, x):
        f, h = self.f, self.h
        return (f(x+h) - f(x-h))/(2*h)
```

This code is included in the `ODESolver.py` file after class `BackwardEuler`.

The next step is to call Newton's method. For this purpose we need to import the `Newton` function from the `Newton` module. The `Newton.py` file must then reside in the same directory as `ODESolver.py`, or `Newton.py` must be in one of the directories listed in the `sys.path` list or the `PYTHONPATH` environment variable (cf. Chapter 4.5.3).

Having the `Newton(f, x_start, dfdx, N)` function from Appendix A.1.10 accessible in our `ODESolver.py` file, we can make a call and supply our `F` function as the argument `f`, a start value for the iteration, here called `w_start`, as the argument `x`, and the derivative `dFdw` for the argument `dfdx`. We rely on default values for the `epsilon` and `store` arguments, while the maximum number of iterations is set to `N=30`. The program is terminated if it happens that the number of iterations exceeds that value, because then the method is not considered to have converged (at least not quickly enough), and we have consequently not been able to compute the next u_{k+1} value.

¹ The local variables in the `advance` function, e.g., `dt` and `u`, act as "global" variables for the `F` function. Hence, when `F` is sent away to some `Newton` function, `F` remembers the values of `dt`, `f`, `t`, and `u`!

The starting value for Newton's method must be chosen. As we expect the solution to not change much from one time level to the next, u_k could be a good initial guess. However, we can do better by using a simple Forward Euler step $u_k + \Delta t f(u_k, t_k)$, which is exactly what we do in the `advance` function above.

Since Newton's method always has the danger of converging slowly, it can be interesting to store the number of iterations at each time level as an attribute in the `BackwardEuler` class. We can easily insert extra statement for this purpose:

```
def advance(self):
    ...
    u_new, n, F_value = Newton(F, w_start, dFdw, N=30)
    if k == 0:
        self.Newton_iter = []
    self.Newton_iter.append(n)
    ...
```

Note the need for creating an empty list (at the first call of `advance`) before we can append elements.

There is now one important question to ask: Will the `advance` method work for systems of ODEs? In that case, $F(w)$ is a vector of functions. The implementation of `F` will work when `w` is a vector, because all the quantities involved in the formula are arrays or scalar variables. The `dFdw` instance will compute a numerical derivative of each component of the vector function `dFdw.f` (which is simply our `F` function). The call to the `Newton` function is more critical: It turns out that this function, as the algorithm behind it, works for scalar equations only. Newton's method can quite easily be extended to a system of nonlinear equations, but we do not consider that topic here. Instead we equip class `BackwardEuler` with a constructor that calls the `f` object and controls that the returned value is a `float` and not an array:

```
class BackwardEuler(ODESolver):
    def __init__(self, f):
        ODESolver.__init__(self, f)
        # Make a sample call to check that f is a scalar function:
        try:
            u = np.array([1]); t = 1
            value = f(u, t)
        except IndexError: # index out of bounds for u
            raise ValueError('f(u,t) must return float/int')
```

Observe that we must explicitly call the superclass constructor and pass on the argument `f` to achieve the right storage and treatment of this argument.

Understanding class `BackwardEuler` implies a good understanding of classes in general; a good understanding of numerical methods for ODEs, for numerical differentiation, and for finding roots of functions; and a good understanding on how to combine different code segments from different parts of the book. Therefore, if you have digested class

BackwardEuler, you have all reasons to believe that you have digested the key topics of this book.

E.2.7 Application 1: $u' = -u$

The perhaps simplest of all ODEs, $u' = -u$, with initial condition $u(0) = 1$, is our first target problem for the classes in the ODESolver hierarchy. The exact solution is $u(t) = e^{-t}$. The basic part of the application of class ForwardEuler goes as follows:

```
import ODESolver

def f(u, t):
    return -u

solver = ODESolver.ForwardEuler(f)
solver.set_initial_condition(1.0)
t_points = linspace(0, 3, 31)
u, t = solver.solve(t_points)
plot(t, u)
```

We can run various values of Δt to see the effect on the accuracy:

```
# Test various dt values and plot
figure()
T = 3
for dt in 2.0, 1.0, 0.5, 0.1:
    n = int(round(T/dt))
    solver = ODESolver.ForwardEuler(f)
    solver.set_initial_condition(1)
    u, t = solver.solve(linspace(0, T, n+1))
    plot(t, u, legend='dt=%g' % dt)
    hold('on')
plot(t, exp(-t), 'bo', legend='exact')
```

Figure E.2 shows alarming results. With $\Delta t = 2$ we get a completely wrong solution that becomes negative and then increasing. The value $\Delta t = 1$ gives a peculiar solution: $u_k = 0$ for $k \geq 1$! Qualitatively correct behavior appears with $\Delta t = 0.5$, and the results get quantitatively better as we decrease Δt . The solution corresponding to $\Delta = 0.1$ looks good from the graph.

We can easily explain what we observe in Figure E.2. For the equation in question, the Forward Euler method computes

$$\begin{aligned} u_1 &= u_0 - \Delta t u_0 = (1 - \Delta t)u_0, \\ u_2 &= u_1 - \Delta t u_1 = (1 - \Delta t)u_1 = (1 - \Delta t)^2 u_0, \\ &\vdots \\ u_k &= (1 - \Delta t)^k u_0. \end{aligned}$$

With $\Delta t = 1$ we simply get $u_k = 0$ for $k \geq 1$. For $\Delta t > 1$, $1 - \Delta t < 0$, and $(1 - \Delta t)^k$ means raising a negative value to an integer power,

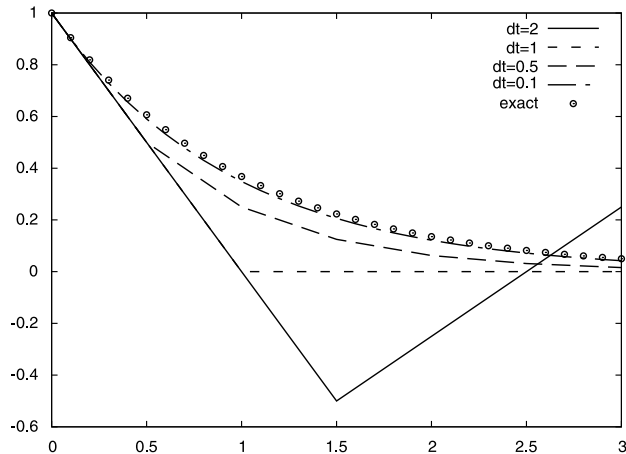

Fig. E.2 Solution of $u' = -u$ for $t \in [0, 3]$ by the Forward Euler method and $\Delta t \in \{2, 1, 0.5, 0.1\}$.

which results in $u_k > 0$ for even k and $u_k < 0$ for odd k . Moreover, $|u_k|$ decreases with k . Such a growing, oscillating solution is of course qualitatively wrong when the exact solution is e^{-t} and monotonically decaying. The conclusion is that the Forward Euler method gives meaningless results for $\Delta t \geq 1$ in the present example.

A particular strength of the `ODESolver` hierarchy of classes is that we can trivially switch from one method to another. For example, we may demonstrate how superior the 4-th order Runge-Kutta method is for this equation: just replace `ForwardEuler` by `RungeKutta4` in the previous code segment and re-run the program. It turns out that the 4-th order Runge-Kutta method gives a monotonically decaying numerical solution for all the tested Δt values. In particular, the solutions corresponding to $\Delta t = 0.5$ and $\Delta t = 0.1$ are visually very close to the exact solution. The conclusion is that the 4-th order Runge-Kutta method is a safer and more accurate method.

Let us compare the two numerical methods in the case where $\Delta t = 0.5$:

```
# Test ForwardEuler vs RungeKutta4
T = 3
dt = 0.5
n = int(round(T/dt))
t_points = linspace(0, T, n+1)
figure()
for solver_class in ODESolver.RungeKutta4, ODESolver.ForwardEuler:
    solver = solver_class(f)
    solver.set_initial_condition(1)
    u, t = solver.solve(t_points)
    plot(t, u, legend='%s' % solver_class.__name__)
    hold('on')
plot(t, exp(-t), 'bo', legend='exact')
```

Figure E.3 illustrates that differences in accuracy between the two methods. The complete program can be found in the file `app1_decay.py`.

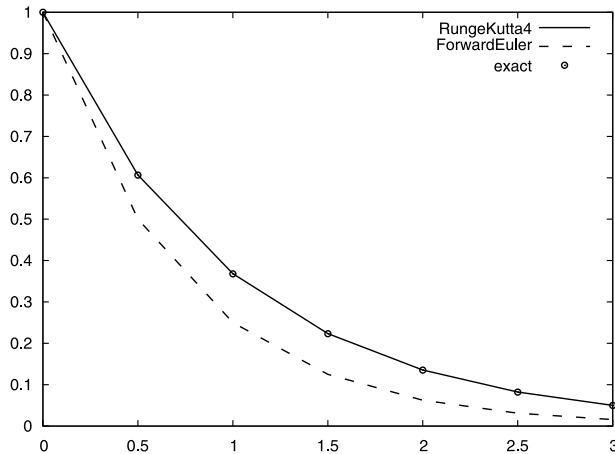

Fig. E.3 Comparison of the Forward Euler and the 4-th order Runge-Kutta method for solving $u' = -u$ for $t \in [0, 3]$ and a time step $\Delta t = 0.5$.

E.2.8 Application 2: The Logistic Equation

The logistic ODE (E.5) is copied here for convenience:

$$u'(t) = \alpha u(t) \left(1 - \frac{u(t)}{R} \right), \quad u(0) = U_0.$$

The right-hand side contains the parameters α and R . We know that $u \rightarrow R$ as $t \rightarrow \infty$, so at some point \hat{t} in time we have approached the asymptotic value $u = R$ within a sufficiently small tolerance and should stop the simulation. This can be done by providing a function as the *tolerance* argument in the `solve` method.

Basic Problem and Solver Classes. Let us, as in Appendix E.1.8, implement the problem-dependent data in a class. This time we store all user-given *physical* data in the class:

```
import ODESolver
from scitools.std import plot, figure
import numpy as np

class Problem:
    def __init__(self, alpha, R, U0, T):
        """
        alpha, R: parameters in the ODE.
        U0: initial condition.
        T: max length of time interval for integration;
        asymptotic value R must be reached within 1%
        accuracy for some t <= T.
        """
        self.alpha, self.R, self.U0, self.T = alpha, R, U0, T

    def __call__(self, u, t):
        """Return f(u,t) for logistic ODE."""
        return self.alpha*u*(1 - u/self.R)

    def terminate(self, u, t, step_no):
```

```

        """Return True when asymptotic value R is reached."""
        tol = self.R*0.01
        return abs(u[step_no] - self.R) < tol

    def __str__(self):
        """Pretty print of physical parameters."""
        return 'alpha=%g, R=%g, U0=%g' % \
            (self.alpha, self.R, self.U0)

```

Note that the tolerance used in the `terminate` method is made dependent on the size of R : if $R = 1000$ we say the asymptotic value is reached when $u \geq 990$. Smaller tolerances will just lead to a solution curve where large parts of it show the boring behavior $u \approx R$.

The solution is obtained the usual way by short code:

```

solver = ODESolver.RungeKutta4(problem)
solver.set_initial_condition(problem.U0)
dt = 1.0
n = int(round(problem.T/dt))
t_points = np.linspace(0, T, n+1)
u, t = solver.solve(t_points, problem.terminate)

```

Let us pack these statements into a class `Solver`, which has two methods: `solve` and `plot`. The code may look like

```

class Solver:
    def __init__(self, problem, dt,
                 method=ODESolver.ForwardEuler):
        """
        problem: instance of class Problem.
        dt: time step.
        method: class in ODESolver hierarchy.
        """
        self.problem, self.dt = problem, dt
        self.solver = method

    def solve(self):
        solver = self.method(self.problem)
        solver.set_initial_condition(self.problem.U0)
        n = int(round(self.problem.T/self.dt))
        t_points = np.linspace(0, self.problem.T, n+1)
        self.u, self.t = solver.solve(t_points,
                                     self.problem.terminate)

        if solver.k+1 == n: # integration to t=T?
            self.plot()
            raise ValueError(
                'termination criterion not reached, '\
                'give T > %g' % self.problem.T)

    def plot(self):
        filename = 'logistic_' + str(self.problem) + '.eps'
        plot(self.t, self.u,
             title=str(self.problem) + ', dt=%g' % self.dt,
             savefig=filename)

```

Problem-dependent data related to the numerical quality of the solution, such as the time step here, go to the `Solver` class. That is, class `Problem` contains the physics and class `Solver` the numerics of the problem under investigation.

If the last computed time step, `solver.k+1`, equals the last possible index, `n`, `problem.terminate` never returned `True`, which means that the asymptotic limit was not reached. This is treated as an erroneous condition. To guide the user, we launch a plot before raising the exception with an instructive message. The complete code is found in the file `app2_logistic.py`.

Computing an Appropriate Δt . Choosing an appropriate Δt is not always so easy. The impact of Δt can sometimes be dramatic, as demonstrated for the Forward Euler method in Appendix E.2.7. We could automate the process of finding a suitable Δt : start with a large Δt , and keep halving Δt until the difference between two solutions corresponding to two consecutive Δt values is small enough.

Say `solver` is a class `Solver` instance computed with time step Δt and `solver2` is the instance corresponding to a computation with $\Delta t/2$. Calculating at the difference between `solver.u` and `solver2.u` is not trivial as (i) one of the arrays has approximately twice as many elements as the other, and (ii) the last element in both arrays does not necessarily correspond to the same time value since the time stepping and the `terminate` function may lead to slightly different termination times.

A solution to these two problems is to turn each of the arrays `solver.u` and `solver2.u` into *continuous functions*, as explained in Appendix E.1.5, and then evaluate the difference at some selected time points up to the smallest value of `solver.t[-1]` and `solver2.t[-1]`. The code becomes

```
# Make continuous functions u(t) and u2(t)
u = wrap2callable((solver.t, solver.u))
u2 = wrap2callable((solver2.t, solver2.u))
# Sample the difference in n points in [0, t_end]
n = 13
t_end = min(solver2.t[-1], solver.t[-1])
t = np.linspace(0, t_end, n)
u_diff = np.abs(u(t) - u2(t)).max()
```

The next step is to introduce a loop where we halve the time step in each iteration and solve the logistic ODE with the new time step and compute `u_diff` as shown above. A complete function takes the form

```
def find_dt(problem, method=ODESolver.ForwardEuler,
            tol=0.01, dt_min=1E-6):
    """
    Return a "solved" class Solver instance where the
    difference in the solution and one with a double
    time step is less than tol.

    problem: class Problem instance.
    method: class in ODESolver hierarchy.
    tol: tolerance (chosen relative to problem.R).
    dt_min: minimum allowed time step.
    """
    dt = problem.T/10 # start with 10 intervals
    solver = Solver(problem, dt, method)
```

```

solver.solve()
from scitools.std import wrap2callable

good_approximation = False
while not good_approximation:
    dt = dt/2.0
    if dt < dt_min:
        raise ValueError('dt=%g < %g - abort' % (dt, dt_min))

    solver2 = Solver(problem, dt, method)
    solver2.solve()

    # Make continuous functions u(t) and u2(t)
    u = wrap2callable((solver.t, solver.u))
    u2 = wrap2callable((solver2.t, solver2.u))

    # Sample the difference in n points in [0, t_end]
    n = 13
    t_end = min(solver2.t[-1], solver.t[-1])
    t = np.linspace(0, t_end, n)
    u_diff = np.abs(u(t) - u2(t)).max()
    print u_diff, dt, tol
    if u_diff < tol:
        good_approximation = True
    else:
        solver = solver2
return solver2

```

Setting the tolerance `tol` must be done with a view to the typical size of u , i.e., the size of R . With $R = 100$ and `tol=1`, the Forward Euler method meets the tolerance for $\Delta t = 0.25$. Switching to the 4-th order Runge-Kutta method makes $\Delta t = 1.625$ sufficient to meet the tolerance. Note that although the latter method can use a significantly larger time step, it also involves four times as many evaluations of the right-hand side function at each time step.

Finally, we show how to make a class that behaves as class `Solver`, but with automatic computation of the time step. If we do not provide a `dt` parameter to the constructor, the `find_dt` function is used to compute `dt` and the solution, otherwise we use the standard `Solver.solve` code. This new class is conveniently realized as a subclass of `Solver` where we override the constructor and the `solve` method. The `plot` method can be inherited as is. The code becomes

```

class AutoSolver(Solver):
    def __init__(self, problem, dt=None,
                 method=ODESolver.ForwardEuler,
                 tol=0.01, dt_min=1E-6):
        Solver.__init__(self, problem, dt, method)
        if dt is None:
            solver = find_dt(self.problem, method,
                             tol, dt_min)
            self.dt = solver.dt
            self.u, self.t = solver.u, solver.t

    def solve(self, method=ODESolver.ForwardEuler):
        if hasattr(self, 'u'):
            # Solution was computed by find_dt in constructor
            pass
        else:
            Solver.solve(self)

```

The call `hasattr(self, 'u')` returns `True` if `u` is an attribute in object `self`. Here this is used as an indicator that the solution was computed in the constructor by the `find_dt` function. A typical use is

```
problem = Problem(alpha=0.1, R=500, U0=2, T=130)
solver = AutoSolver(problem, tol=1)
solver.solve(method=ODESolver.RungeKutta4)
solver.plot()
```

Dealing with Time-Dependent Coefficients. The carrying capacity of the environment, R , may vary with time, e.g., due to seasonal changes. Can we extend the previous code so that R can be specified either as a constant or as a function of time?

This is in fact easy if we in the implementation of the right-hand side function assume that R is a function of time. If it is given as a constant in the constructor of class `Problem`, we just wrap it as a function of time:

```
if isinstance(R, (float,int)): # number?
    self.R = lambda t: R
elif callable(R):
    self.R = R
else:
    raise TypeError(
        'R is %s, has to be number of function' % type(R))
```

The `terminate` method is also affected as we need to base the tolerance on the R value at the present time level. Also the `__str__` method must be changed since it is not meaningful to print a function `self.R`. That is, all methods in the generalized problem class, here called `Problem2`, must be altered. We have not chosen to make `Problem2` a subclass of `Problem`, even though the interface is the same and the two classes are closely related. While `Problem` is clearly a special case of `Problem2`, as a constant R is a special case of a function (R), the opposite case is not true.

Class `Problem2` becomes

```
class Problem2(Problem):
    def __init__(self, alpha, R, U0, T):
        """
        alpha, R: parameters in the ODE.
        U0: initial condition.
        T: max length of time interval for integration;
        asymptotic value R must be reached within 1%
        accuracy for some t <= T.
        """
        self.alpha, self.U0, self.T = alpha, U0, T
        if isinstance(R, (float,int)): # number?
            self.R = lambda t: R
        elif callable(R):
            self.R = R
        else:
            raise TypeError(
                'R is %s, has to be number of function' % type(R))
```

```

def __call__(self, u, t):
    """Return f(u,t) for logistic ODE."""
    return self.alpha*u*(1 - u/self.R(t))

def terminate(self, u, t, step_no):
    """Return True when asymptotic value R is reached."""
    tol = self.R(t[step_no])*0.01
    return abs(u[step_no] - self.R(t[step_no])) < tol

def __str__(self):
    return 'alpha=%g, U0=%g' % (self.alpha, self.U0)

```

We can compute the case where $R = 500$ for $t < 60$ and then reduced to $R = 100$ because of an environmental crisis (see Figure E.4):

```

problem = Problem2(alpha=0.1, U0=2, T=130,
                  R=lambda t: 500 if t < 60 else 100)
solver = AutoSolver(problem, tol=1)
solver.solve(method=ODESolver.RungeKutta4)
solver.plot()

```

Note the use of a lambda function (Chapter 3.1.11) to save some typing when specifying R . The corresponding graph is made of two parts, basically exponential growth until the environment changes and then exponential reduction until u approaches the new R value and the change in u becomes small.

Reading Input. Our final version of the problem class is equipped with functionality for reading data from the command line in addition to setting data explicitly in the program. We use the `argparse` module described in Chapter 4.2.4. The idea now is to have a constructor that just sets default values. Then we have a method for defining the command-line arguments and a method for transforming the `argparse` information

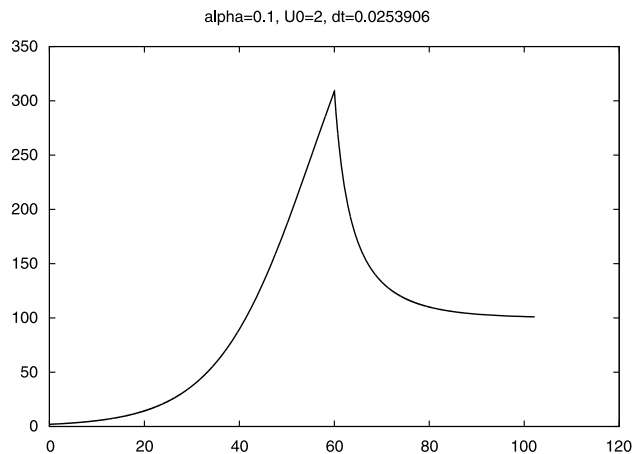

Fig. E.4 Solution of the logistic equation $u' = \alpha u(1 - u/R(t))$ when $R = 500$ for $t < 60$ and $R = 100$ for $t \geq 60$.

to the attributes `alpha`, `U0`, `R`, and `T`. The `R` attribute is supposed to be a function, and we use the `StringFunction` tool to turn strings from the command-line into a Python function of time `t`.

The code of our new problem class is listed next.

```
class Problem3(Problem):
    def __init__(self):
        # Set default parameter values
        self.alpha = 1.
        self.R = StringFunction('1.0', independent_variable='t')
        self.U0 = 0.01
        self.T = 4.

    def define_command_line_arguments(self, parser):
        """Add arguments to parser (argparse.ArgumentParser)."""

    def evalcmlarg(text):
        return eval(text)

    def toStringFunction(text):
        return StringFunction(text, independent_variable='t')

    parser.add_argument(
        '--alpha', dest='alpha', type=evalcmlarg,
        default=self.alpha,
        help='initial growth rate in logistic model')
    parser.add_argument(
        '--R', dest='R', type=toStringFunction, default=self.R,
        help='carrying capacity of the environment')
    parser.add_argument(
        '--U0', dest='U0', type=evalcmlarg, default=self.U0,
        help='initial condition')
    parser.add_argument(
        '--T', dest='T', type=evalcmlarg, default=self.T,
        help='integration in time interval [0,T]')
    return parser

    def set(self, **kwargs):
        """
        Set parameters as keyword arguments alpha, R, U0, or T,
        or as args (object returned by parser.parse_args()).
        """
        for prm in ('alpha', 'U0', 'R', 'T'):
            if prm in kwargs:
                setattr(self, prm, kwargs[prm])
        if 'args' in kwargs:
            args = kwargs['args']
            for prm in ('alpha', 'U0', 'R', 'T'):
                if hasattr(args, prm):
                    setattr(self, prm, getattr(args, prm))
            else:
                print 'Really strange', dir(args)

    def __call__(self, u, t):
        """Return f(u,t) for logistic ODE."""
        return self.alpha*u*(1 - u/self.R(t))

    def terminate(self, u, t, step_no):
        """Return True when asymptotic value R is reached."""
        tol = self.R(t[step_no])*0.01
        return abs(u[step_no] - self.R(t[step_no])) < tol

    def __str__(self):
        s = 'alpha=%g, U0=%g' % (self.alpha, self.U0)
        if isinstance(self.R, StringFunction):
```

```
s += ', R=%s' % str(self.R)
return s
```

The calls to `parser.add_argument` are straightforward, but notice that we allow strings for α , U_0 , and T to be interpreted by `eval`. The string for R is interpreted as a formula by `StringFunction`. The `set` method is flexible: it accepts any set of keyword arguments, and checks first if these are the names of the problem parameters, and thereafter if `args='` is given, which implies that the parameters are taken from the command line. The rest of the class is very similar to earlier versions.

The typical use of class `Problem3` is shown below. First we set parameters directly:

```
problem = Problem3()
problem.set(alpha=0.1, U0=2, T=130,
            R=lambda t: 500 if t < 60 else 100)
solver = AutoSolver(problem, tol=1)
solver.solve(method=ODESolver.RungeKutta4)
solver.plot()
```

Then we rely on reading parameters from the command line:

```
problem = Problem3()
import argparse
parser = argparse.ArgumentParser(
    description='Logistic ODE model')
parser = problem.define_command_line_arguments(parser)

# Try --alpha 0.11 --T 130 --U0 2 --R '500 if t < 60 else 300'
args = parser.parse_args()
problem.set(args=args)
solver = AutoSolver(problem, tol=1)
solver.solve(method=ODESolver.RungeKutta4)
solver.plot()
```

The last example using a problem class integrated with the command line is the most flexible way of implementing ODE models.

E.2.9 Application 3: An Oscillating System

The motion of a box attached to a spring, as described in Appendix D, can be modeled by two first-order differential equations as listed in (E.32), here repeated with $F(t) = mw''(t)$ for convenience:

$$\begin{aligned}\frac{du^{(0)}}{dt} &= u^{(1)}, \\ \frac{du^{(1)}}{dt} &= w''(t) + g - m^{-1}\beta u^{(1)} - m^{-1}ku^{(0)}.\end{aligned}$$

The $w(t)$ function is the forced movement of the end of the spring.

The code related to this example is found in `app3_osc.py`. Because our right-hand side f contains several parameters, we implement it as

a class with the parameters as attributes and a `__call__` method for returning the 2-vector f . We assume that the user of the class supplies the $w(t)$ function, so it is natural to compute $w''(t)$ by a finite difference formula.

```
class OscSystem:
    def __init__(self, m, beta, k, g, w):
        self.m, self.beta, self.k, self.g, self.w = \
            float(m), float(beta), float(k), float(g), w

    def __call__(self, u, t):
        u0, u1 = u
        m, beta, k, g, w = \
            self.m, self.beta, self.k, self.g, self.w
        # Use a finite difference for w''(t)
        h = 1E-5
        ddw = (w(t+h) - 2*w(t) + w(t-h))/(h**2)
        f = [u1, ddw + g - beta/m*u1 - k/m*u0]
        return f
```

A simple test case arises if we set $m = k = 1$ and $\beta = g = w = 0$:

$$\begin{aligned}\frac{du^{(0)}}{dt} &= u^{(1)}, \\ \frac{du^{(1)}}{dt} &= -u^{(0)}.\end{aligned}$$

Suppose that $u^{(0)}(0) = 1$ and $u^{(1)}(0) = 0$. An exact solution is then

$$u^{(0)}(t) = \cos t, \quad u^{(1)}(t) = -\sin t.$$

We can use this case to check how the Forward Euler method compares with the 4-th order Runge-Kutta method:

```
import ODESolver
from scitools.std import *
f = OscSystem(1.0, 0.0, 1.0, 0.0, lambda t: 0)
u_init = [1, 0] # initial condition
nperiods = 3.5 # no of oscillation periods
T = 2*pi*nperiods
for solver_class in ODESolver.ForwardEuler, ODESolver.RungeKutta4:
    if solver_class == ODESolver.ForwardEuler:
        npoints_per_period = 200
    elif solver_class == ODESolver.RungeKutta4:
        npoints_per_period = 20
    n = npoints_per_period*nperiods
    t_points = linspace(0, T, n+1)
    solver = solver_class(f)
    solver.set_initial_condition(u_init)
    u, t = solver.solve(t_points)

# u is an array of [u0,u1] pairs for each time level,
# get the u0 values from u for plotting
u0_values = u[:, 0]
u1_values = u[:, 1]
u0_exact = cos(t)
u1_exact = -sin(t)
figure()
alg = solver_class.__name__ # (class) name of algorithm
plot(t, u0_values, 'r-')
```

```

t, u0_exact, 'b-',
legend=('numerical', 'exact'),
title='Oscillating system; position - %s' % alg,
savefig='tmp_oscsystem_pos_%s.eps' % alg)
figure()
plot(t, u1_values, 'r-',
t, u1_exact, 'b-',
legend=('numerical', 'exact'),
title='Oscillating system; velocity - %s' % alg,
savefig='tmp_oscsystem_vel_%s.eps' % alg)

```

For this particular application it turns out that the 4-th order Runge-Kutta is very accurate, even with few (20) time steps per oscillation. Unfortunately, the Forward Euler method leads to a solution with increasing amplitude in time. Figure E.5 shows a comparison between the two methods. Note that the Forward Euler method uses 10 times as many time steps as the 4-th order Runge-Kutta method and is still much less accurate. A very much smaller time step is needed to limit the growth of the Forward Euler scheme for oscillating systems.

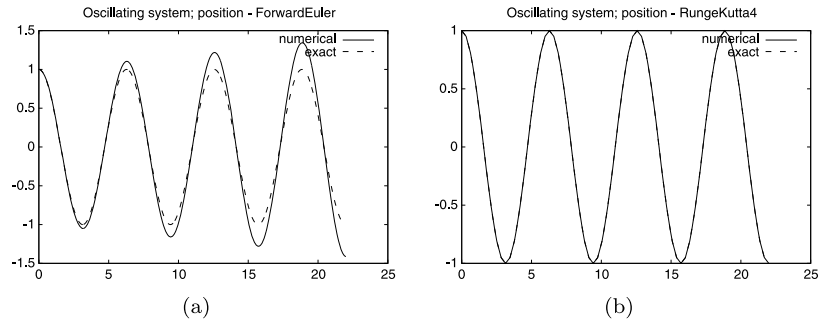

Fig. E.5 Solution of an oscillating system ($u'' + u = 0$ formulated as system of two ODEs) by (a) the Forward Euler method with $\Delta t = 2\pi/200$; and (b) the 4-th order Runge-Kutta method with $\Delta t = 2\pi/20$.

E.2.10 Application 4: The Trajectory of a Ball

Exercise 1.13 derives the following two second-order differential equations for the motion of a ball (neglecting air resistance):

$$\frac{d^2x}{dt^2} = 0, \quad (\text{E.50})$$

$$\frac{d^2y}{dt^2} = -g, \quad (\text{E.51})$$

where (x, y) is the position of the ball (x is a horizontal measure and y is a vertical measure), and g is the acceleration of gravity. To use numerical methods for first-order equations, we must rewrite the system of two second-order equations as a system of four first-order equations.

This is done by introducing to new unknowns, the velocities $v_x = dx/dt$ and $v_y = dy/dt$. We then have the first-order system of ODEs

$$\frac{dx}{dt} = v_x, \quad (\text{E.52})$$

$$\frac{dv_x}{dt} = 0, \quad (\text{E.53})$$

$$\frac{dy}{dt} = v_y, \quad (\text{E.54})$$

$$\frac{dv_y}{dt} = -g. \quad (\text{E.55})$$

The initial conditions are

$$x(0) = 0, \quad (\text{E.56})$$

$$v_x(0) = v_0 \cos \theta, \quad (\text{E.57})$$

$$y(0) = y_0, \quad (\text{E.58})$$

$$v_y(0) = v_0 \sin \theta, \quad (\text{E.59})$$

where v_0 is the initial magnitude of the velocity of the ball. The initial velocity has a direction that makes the angle θ with the horizontal.

The code related to this example is found in `app4_ball.py`. A function returning the right-hand side of our ODE system reads

```
def f(u, t):
    x, vx, y, vy = u
    g = 9.81
    return [vx, 0, vy, -g]
```

It makes sense to solve the ODE system as long as the ball is above the ground, i.e., as long as $y \geq 0$. We must therefore supply a `terminate` function as explained on page 686:

```
def terminate(u, t, step_no):
    return False if u[step_no,2] >= 0 else True
```

Observe that all the y values are given by `u[:,2]` and we want to test the value at the current step, which becomes `u[step_no,2]`.

The main program for solving the ODEs can be set up as

```
v0 = 5
theta = 80*pi/180
U0 = [0, v0*cos(theta), 0, v0*sin(theta)]
T = 1.2; dt = 0.01; n = int(round(T/dt))
solver = ODESolver.ForwardEuler(f)
solver.set_initial_condition(U0)

def terminate(u, t, step_no):
    return False if u[step_no,2] >= 0 else True

u, t = solver.solve(linspace(0, T, n+1), terminate)
```

Now, $u[:,0]$ represents all the $x(t)$ values, $u[:,1]$ all the $v_x(t)$ values, $u[:,2]$ all the $y(t)$ values, and $u[:,3]$ all the $v_y(t)$ values. To plot the trajectory, y versus x , we write

```
x = u[:,0]
y = u[:,2]
plot(x, y)
```

The exact solution is given by (1.5), so we can easily assess the accuracy of the numerical solution. Figure E.6 shows a comparison of the numerical and the exact solution in this simple test problem. Note that even if we are just interested in y as a function of x , we first need to solve the complete ODE system for $x(t)$, $v_x(t)$, $y(t)$, and $v_y(t)$.

The real strength of the numerical approach is the ease with which we can add air resistance and lift to the system of ODEs. Insight in physics is necessary to derive what the additional terms are, but implementing the terms is trivial in our program above (do Exercise E.32).

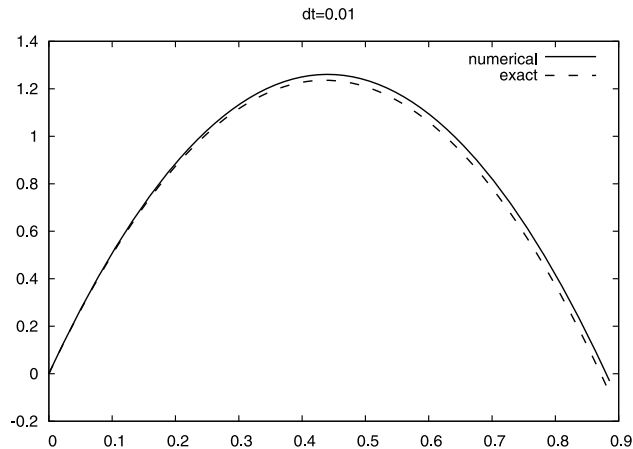

Fig. E.6 The trajectory of a ball solved as a system of four ODEs by the Forward Euler method.

E.2.11 Further Developments of ODESolver

The `ODESolver` hierarchy is a simplified prototype version of a more professional Python package for solving ODEs called `Odespy`. This package features a range of simple and sophisticated methods for solving scalar ODEs and systems of ODEs. Some of the solvers are implemented in Python, while others call up well-known ODE software in Fortran. Like the `ODESolver` hierarchy, `Odespy` offers a unified interface to the different numerical methods, which means that the user can specify the ODE problem as a function $f(u, \tau)$ and send this function to all solvers. This

feature makes it easy to switch between solvers to test a wide collection of numerical methods for a problem.

Odespy can be downloaded from <http://hplgit.github.com/odespy/>. It is installed by the usual `python setup.py install` command.

E.3 Exercises

Exercise E.1. *Solve a simple ODE in two ways.*

The purpose of this exercise is to solve the ODE problem $u - 10u' = 0$, $u(0) = 0.2$, for $t \in [0, 20]$. Use both the `ForwardEuler` *function* from Appendix E.1.3 and the `ForwardEuler` *class* from Appendix E.1.7. Set $\Delta t = 1$. Check that the results produced by the two equivalent methods coincide. Name of program file: `simple_ODE.py`. \diamond

Exercise E.2. *Use the ODESolver hierarchy to solve a simple ODE.*

Solve the ODE problem $u' = u/2$ with $u(0) = 1$, using a class in the `ODESolver` hierarchy. Choose $\Delta t = 0.5$ and find $u(t)$ for $t \in [0, 6]$. Write out the approximate final u_n value together with the exact value e^3 . Repeat the calculations for $\Delta t = 0.001$. Name of program file: `ODESolver_demo.py`. \diamond

Exercise E.3. *Solve an ODE for emptying a tank.*

A cylindrical tank of radius R is filled with water to a height h_0 . By opening a valve of radius r at the bottom of the tank, water flows out, and the height of water, $h(t)$, decreases with time. We can derive an ODE that governs the height function $h(t)$.

Mass conservation of water requires that the reduction in height balances the outflow. In a time interval Δt , the height is reduced by Δh , which corresponds to a water volume of $\pi R^2 \Delta h$. The water leaving the tank in the same interval of time equals $\pi r^2 v \Delta t$, where v is the outflow velocity. It can be shown (from what is known as Bernoulli's equation) that

$$v(t) = \sqrt{2gh(t) + h'(t)^2},$$

g being the acceleration of gravity [6, 11]. Note that $\Delta h > 0$ implies an increase in h , which means that $-\pi R^2 \Delta h$ is the corresponding decrease in volume that must balance the outflow loss of volume $\pi r^2 v \Delta t$. Elimination of v and taking the limit $\Delta t \rightarrow 0$ lead to the ODE

$$\frac{dh}{dt} = -\left(\frac{r}{R}\right)^2 \left(1 - \left(\frac{r}{R}\right)^4\right)^{-1/2} \sqrt{2gh}.$$

For practical applications $r \ll R$ so that $1 - (r/R)^4 \approx 1$ is a reasonable approximation (friction is neglected in the derivation, and we are also going to solve the ODE by approximate methods). The final ODE then

becomes

$$\frac{dh}{dt} = -\left(\frac{r}{R}\right)^2 \sqrt{2gh}. \quad (\text{E.60})$$

The initial condition follows from the initial height of water, h_0 , in the tank: $h(0) = h_0$.

Solve (E.60) by a numerical method of your choice in a program. Set $r = 1$ cm, $R = 20$ cm, $g = 9.81$ m/s², and $h_0 = 1$ m. Use a time step of 10 seconds. Plot the solution, and experiment to see what a proper time interval for the simulation is. Make sure to test for $h < 0$ so that you do not apply the square root function to negative numbers. Can you find an analytical solution of the problem to compare the numerical solution with? Name of program file: tank_ODE.py. \diamond

Exercise E.4. *Scale the logistic equation.*

Consider the logistic model (E.5):

$$u'(t) = \alpha u(t) \left(1 - \frac{u(t)}{R}\right), \quad u(0) = U_0.$$

This problem involves three input parameters: U_0 , R , and α . Learning how u varies with U_0 , R , and α requires much experimentation where we vary all three parameters and observe the solution. A much more effective approach is to *scale* the problem. By this technique the solution depends only on one parameter U_0/R in the present problem. This exercise tells how the scaling is done.

The idea of scaling is to introduce *dimensionless* versions of the independent and dependent variables:

$$v = \frac{u}{u_c}, \quad \tau = \frac{t}{t_c},$$

where u_c and t_c are characteristic sizes of u and t , respectively, such that the dimensionless variables v and τ are of approximately unit size. Since we know that $u \rightarrow R$ as $t \rightarrow \infty$, R can be taken as the characteristic size of u .

Insert $u = Rv$ and $t = t_c\tau$ in the governing ODE and choose $t_c = 1/\alpha$. Show that the ODE for the new function $v(\tau)$ becomes

$$\frac{dv}{d\tau} = v(1 - v), \quad v(0) = v_0. \quad (\text{E.61})$$

We see that the three parameters U_0 , R , and α have disappeared from the ODE problem, and only one parameter $v_0 = U_0/R$ is involved.

Show that if $v(\tau)$ is computed, one can recover $u(t)$ by

$$u(t) = Rv(\alpha t). \quad (\text{E.62})$$

Geometrically, the transformation from v to u is just a stretching of the two axis in the coordinate system.

Make a program `logistic_scaled.py` where you compute $v(\tau)$, given $v_0 = 0.05$, and then you use (E.62) to plot $u(t)$ for $R = 100, 500, 1000$ and $\alpha = 1$ in one figure, and $u(t)$ for $\alpha = 1, 5, 10$ and $R = 1000$ in another figure. Note how effectively you can generate $u(t)$ without needing to solve an ODE problem, and also note how varying R and α impacts the graph of $u(t)$. Name of program file: `logistic_scaled.py`.

◇

Exercise E.5. *Compute logistic growth with time-varying carrying capacity.*

Use classes `Problem2` and `AutoSolver` from Appendix E.2.8 to study logistic growth when the carrying capacity of the environment, R , changes periodically with time: $R = 500$ for $it_s \leq t < (i + 1)t_s$ and $R = 200$ for $(i + 1)t_s \leq t < (i + 2)t_s$, with $i = 0, 2, 4, 6, \dots$. Use the same data as in Appendix E.2.8, and find some relevant sizes of the period of variation, t_s , to experiment with. Name of program file: `seasonal_logistic_growth.py`.

◇

Exercise E.6. *Solve an ODE for the arc length.*

Given a curve $y = f(x)$, the length of the curve from $x = x_0$ to some point x is given by the function $s(x)$, which solves the problem

$$\frac{ds}{dx} = \sqrt{1 + [f'(x)]^2}, \quad s(x_0) = 0. \quad (\text{E.63})$$

Since s does not enter the right-hand side, (E.63) can immediately be integrated from x_0 to x (see Exercise A.17). However, we shall solve (E.63) as an ODE. Use the Forward Euler method and compute the length of a straight line (for easy verification) and a parabola: $f(x) = \frac{1}{2}x + 1$, $x \in [0, 2]$; $f(x) = x^2$, $x \in [0, 2]$. Name of program file: `arclength_ODE.py`.

◇

Exercise E.7. *Compute inverse functions by solving an ODE.*

The inverse function g of some function $f(x)$ takes the value $f(x)$ back to x again: $g(f(x)) = x$. The common technique to compute inverse functions is to set $y = f(x)$ and solve with respect to x . The formula on the right-hand side is then the desired inverse function $g(y)$. Exercise 7.26 makes use of such an approach, where $y - f(x) = 0$ is solved numerically with respect to x for different discrete values of y .

We can formulate a general procedure for computing inverse functions from an ODE problem. If we differentiate $y = f(x)$ with respect to y , we get $1 = f'(x) \frac{dx}{dy}$ by the chain rule. The inverse function we seek is $x(y)$, but this function then fulfills the ODE

$$x'(y) = \frac{1}{f'(x)}. \quad (\text{E.64})$$

That y is the independent coordinate and x the function of y can be a somewhat confusing notation, so you might introduce u and t for x and y :

$$u'(t) = \frac{1}{f'(u)}.$$

The initial condition is $x(0) = x_r$ where x_r solves the equation $f(x_r) = 0$ ($x(0)$ implies $y = 0$ and then from $y = f(x)$ it follows that $f(x(0)) = 0$).

Make a program that can use the described method to compute $x(y)$, given $f(x)$ and x_r . Use any numerical method of your choice for solving the ODE problem. Plot $f(x)$ as well as $x(y)$. Verify the implementation for $f(x) = 2x$. Test the method for $f(x) = \sqrt{x}$. Name of program file: `inverse_ODE.py`. \diamond

Exercise E.8. *Generalize the implementation in Exer. E.7.*

The method for computing inverse functions described in Exercise E.7 is very general. The purpose now is to make a reusable utility, here called `Inverse`, for computing the inverse of some Python function $f(x)$ on some interval $I=[a,b]$. The utility can be used as follows to calculate the inverse of $\sin x$ on $I = [0, \pi/2]$:

```
def f(x):
    return sin(x)

# Compute the inverse of f
inverse = Inverse(f, x0=0, I=[0, pi/2], resolution=100)
x, y = Inverse.compute()
from scitools.std import plot

plot(y, x, 'r-',
      x, f(x), 'b-',
      y, asin(y), 'go')
legend(['computed inverse', 'f(x)', 'exact inverse'])
```

Here, `x0` is the value of x at 0, or in general at the left point of the interval: $I[0]$. The parameter `resolution` tells how many equally sized intervals Δy we use in the numerical integration of the ODE. A default choice of 1000 can be used if it is not given by the user.

Make class `Inverse` and put it in a module. Include a function `_verify()` in the module which tests that class `Inverse` gives exact solution for the test problem $f(x) = 2x$. Name of program file: `Inverse1.py`. \diamond

Exercise E.9. *Extend the implementation in Exer. E.8.*

Extend the module in Exercise E.8 such that the value of $x(0)$ (`x0` in class `Inverse`'s constructor) does not need to be provided by the user. To this end, class `Inverse` must solve $f(x) = 0$ and set `x0` equal to the root. You may use the Bisection method from Chapter 4.6.2, Newton's method from Appendix A.1.10, or the Secant method from Exercise A.14 to solve $f(x) = 0$. Class `Inverse` should figure out a

suitable initial interval for the Bisection method or start values for the Newton or Secant methods. Computing $f(x)$ for x at many points and examining these may help in solving $f(x) = 0$ without any input from the user. Name of program file: `Inverse2.py`. \diamond

Exercise E.10. *Compute inverse functions by interpolation.*

Instead of solving an ODE for computing the inverse function $g(y)$ of some function $f(x)$, as explained in Exercise E.7, one may use a simpler approach based on ideas from Appendix E.1.5. Say we compute discrete values of x and $f(x)$, stored in the arrays `x` and `y`. Doing a `plot(x, y)` shows $y = f(x)$ as a function of x , and doing `plot(y, x)` shows x as a function of y , i.e., we plot the inverse function $g(y)$. It is therefore trivial to plot the inverse function!

However, if we want the inverse function of $f(x)$ as some Python function $g(y)$ that we can call for any y , we can use the tool `wrap2callable` from Appendix E.1.5 to turn the discrete inverse function, described by the arrays `y` (independent coordinate) and `x` (dependent coordinate), into a continuous function $g(y)$:

```
from scitools.std import wrap2callable
g = wrap2callable((y, x))

y = 0.5
print g(y)
```

The $g(y)$ function applies linear interpolation in each interval between the points in the `y` array.

Implement this method in a program. Verify the implementation for $f(x) = 2x$ for $x \in [0, 4]$ and test it for $f(x) = \sin x$ for $x \in [0, \pi/2]$. Name of program file: `inverse_wrap2callable.py`. \diamond

Exercise E.11. *Simulate a falling or rising body in a fluid.*

A body moving vertically through a fluid (liquid or gas) is subject to three different types of forces:

1. the gravity force $F_g = -mg$, where m is the mass of the body and g is the acceleration of gravity;
2. the drag force² $F_d = -\frac{1}{2}C_D\rho A|v|v$ (see also Exercise 1.11), where C_D is a dimensionless drag coefficient depending on the body's shape, ρ is the density of the fluid, A is the cross-sectional area (produced by a cutting plane $y = \text{const}$ through the thickest part of the body), and v is the velocity;
3. the uplift or buoyancy force ("Archimedes force") $F_b = \rho gV$, where V is the volume of the body.

² Roughly speaking, the F_d formula is suitable for medium to high velocities, while for very small velocities, or very small bodies, F_d is proportional to the velocity, not the velocity squared, see [11].

Newton's second law applied to the body says that the sum of these forces must equal the mass of the body times its acceleration a :

$$F_g + F_d + F_b = ma,$$

which gives

$$-mg - \frac{1}{2}C_D\rho A|v|v + \rho gV = ma.$$

The unknowns here are v and a , i.e., we have two unknowns but only one equation. From kinematics in physics we know that the acceleration is the time derivative of the velocity: $a = dv/dt$. This is our second equation. We can easily eliminate a and get a single differential equation for v :

$$-mg - \frac{1}{2}C_D\rho A|v|v + \rho gV = m\frac{dv}{dt}.$$

A small rewrite of this equation is handy: We express m as $\rho_b V$, where ρ_b is the density of the body, and we isolate dv/dt on the left-hand side,

$$\frac{dv}{dt} = -g\left(1 - \frac{\rho}{\rho_b}\right) - \frac{1}{2}C_D\frac{\rho A}{\rho_b V}|v|v. \quad (\text{E.65})$$

This differential equation must be accompanied by an initial condition: $v(0) = V_0$.

Make a program for solving (E.65) numerically, using any numerical method of your choice. Implement the right-hand side of (E.65) in the `--call--` method of a class where the parameters g , ρ , ρ_b , C_D , A , and V are attributes.

To verify the program, assume a heavy body in air such that the F_b force can be neglected, and assume a small velocity such that the air resistance F_d can also be neglected. Setting $\rho = 0$ removes both these terms from the equation. The motion then leads to the exact velocity $v(t) = y'(t) = v_0 - gt$. See how well the program reproduces this simple solution.

After the program is verified, we are ready to run two real examples and plot the evolution of v :

1. *Parachute jumper.* The point is to compute the motion of a parachute jumper in free fall before the parachute opens. We set the density of the human body as $\rho_b = 1003 \text{ kg/m}^3$ and the mass as $m = 80 \text{ kg}$, implying $V = m/\rho_b = 0.08 \text{ m}^3$. We can base the cross-sectional area A on the height 1.8 m and a width of 50 cm, giving $A \approx \pi R^2 = 0.9 \text{ m}^2$. The density of air decreases with height, and we here use the value 0.79 kg/m^3 which is relevant for about 5000 m height. The C_D coefficient can be set as 0.6. Start with $v_0 = 0$.
2. *Rising ball in water.* A ball with the size of a soccer ball is placed in deep water, and we seek to model its motion upwards. Contrary to

the former example, where the buoyancy force F_b is very small, F_b is now the driving force, and the gravity force F_g is small. Set $A = \pi a^2$ with $a = 11$ cm, the mass of the ball is 0.43 kg, the density of water is 1000 kg/m^3 , and C_D is 0.2. Start with $v_0 = 0$ and see how the ball rises.

Name of program file: `body_in_fluid.py`. \diamond

Exercise E.12. *Check the solution's limit in Exer. E.11.*

The solution of (E.65) often tends to a constant velocity, called the terminal velocity. This happens when the sum of the forces, i.e., the right-hand side in (E.65) vanishes. Compute the formula for the terminal velocity by hand. Solve the ODE using class `ODESolver` and call the `solve` method with a `terminate` function that terminates the computations when a constant velocity is reached, that is, when $|v(t_n) - v(t_{n-1})| \leq \epsilon$, where ϵ is a small number. Run a series of Δt values and make a graph of the terminal velocity as a function of Δt for the two cases in Exercise E.11. Indicate the exact terminal velocity in the plot by a horizontal line. Would you expect the accuracy of the computed terminal velocity to increase with decreasing Δt ? Discuss! Name of program file: `body_in_fluid_termvel.py`. \diamond

Exercise E.13. *Visualize the different forces in Exer. E.11.*

The purpose of this exercise is to plot the forces F_g , F_b , and F_d in the model from Exercise E.11 as functions of t . Seeing the relative importance of the forces as time develops gives an increased understanding of how the different forces contribute to change the velocity. Name of program file: `body_in_fluid_forces.py`. \diamond

Exercise E.14. *Solve an ODE until constant solution.*

Newton's law of cooling,

$$\frac{dT}{dt} = -h(T - T_s) \quad (\text{E.66})$$

can be used to see how the temperature T of an object changes because of heat exchange with the surroundings, which have a temperature T_s . The parameter h , with unit s^{-1} is an experimental constant (heat transfer coefficient) telling how efficient the heat exchange with the surroundings is. For example, (E.66) may model the cooling of a hot pizza taken out of the oven. The problem with applying (E.66), nevertheless, is that h must be measured. Suppose we have measured T at $t = 0$ and t_1 . We can use a rough Forward Euler approximation of (E.66) with one time step of length t_1 ,

$$\frac{T(t_1) - T(0)}{t_1} = -h(T(0) - T_s),$$

to make the estimate

$$h = \frac{T(t_1) - T(0)}{t_1(T_s - T(0))}. \quad (\text{E.67})$$

Suppose now you take a hot pizza out of the oven. The temperature of the pizza is 200 C at $t = 0$ and 180 C after 50 seconds, in a room with temperature 20 C. Find an estimate of h from the formula above.

Solve (E.66) to find the evolution of the temperature of the pizza. Use class `ForwardEuler` or `RungeKutta4`, and supply a `terminate` function to the `solve` method so that the simulation stops when T is sufficiently close to the final room temperature T_s . Plot the solution. Name of program file: `pizza_cooling1.py`. \diamond

Exercise E.15. *Use classes in Exer. E.14.*

Solve Exercise E.14 with a class `Problem` containing the parameters h , T_s , $T(0)$, and Δt as attributes. A method `estimate_h` should take t_1 and $T(t_1)$ as arguments, compute h , and assign it to `self.h`. Also a method `__call__` for computing the right-hand side must be included. The `terminate` function can be a method in the class, a stand-alone function, or a lambda function. By using class `Problem`, we avoid having the physical parameters as global variables in the program and all the problem-specific data are packed into one object.

Write a function `solve(problem)` that takes a `Problem` object with name `problem` as argument, solves the ODE, and plots the solution. We now want to run experiments with different values of some parameters: $T_s = 15, 22, 30$ C and $T(0) = 250, 200$ C. Make a list of `Problem` objects and plot the solution for each problem in the same figure:

```
# Given h and dt
problems = [Problem(h, T_s, T_0, dt) \
            for T_s in 15, 22, 30 for T_0 in 250, 200]
for problem in problems:
    solve(problem)
    hold('on')
```

Name of program file: `pizza_cooling2.py`. \diamond

Exercise E.16. *Scale away parameters in Exer. E.14.*

Use the scaling approach from Appendix E.2.8 to “scale away” the parameters in the ODE in Exercise E.14. That is, introduce a new unknown $u = (T - T_s)/(T(0) - T_s)$ and a new time scale $\tau = th$. Find the ODE and the initial condition that governs the $u(\tau)$ function. Make a program that computes $u(\tau)$ until $|u| < 0.001$. Store the discrete u and τ values in a file `u_tau.dat` if that file is not already present (you can use `os.path.isfile(f)` to test if a file with name `f` exists). Create a function `T(u, tau, h, T0, Ts)` that loads the u and τ data from the `u_tau.dat` file and returns two arrays with T and t values, corresponding to the computed arrays for u and τ . Plot T versus t . Give the parameters h , T_s , and $T(0)$ on the command line. Note that this program is supposed to solve the ODE once and then recover any

$T(t)$ solution by a simple scaling of the single $u(\tau)$ solution. Name of program file: `pizza_cooling3.py`. \diamond

Exercise E.17. *Use the 4th-order Runge-Kutta on (C.34).*

Investigate if the 4th-order Runge-Kutta method is better than the Forward Euler scheme for solving the challenging ODE problem (C.34) from Exercise C.3 on page 639. Name of program file: `yx_ODE2.py`. \diamond

Exercise E.18. *Compare ODE methods.*

The equation $u' = -au$ is a relevant model for radioactive decay, where $u(t)$ is the fraction of particles that remains in the radioactive substance at time t . The parameter a is the inverse of the so-called mean lifetime of the substance. The initial condition is $u(0) = 1$.

Introduce a class `Decay` to hold information about the physical problem: the parameter a and a `__call__` method for computing the right-hand side $-au$ of the ODE. Initialize an instance of class `Decay` with $a = \ln(2)/5600$ 1/y (y means the unit years, and this value of a corresponds to the Carbon-14 radioactive isotope whose decay is used extensively in dating organic material that is tens of thousands of years old).

Solve (E.7) by both the Forward Euler and the 4-th order Runge-Kutta method, using the `ForwardEuler` and the `RungeKutta4` classes in the `ODESolver` hierarchy. Use a time step of 500 years, and simulate decay for $T = 20,000$ y (let the time unit be 1 y). Plot the two solutions. Write out the final $u(T)$ value and compare it with the exact value e^{-aT} . Name of program file: `radioactive_decay.py`. \diamond

Exercise E.19. *Compare ODE methods.*

Consider the problem described in Exercise E.3 on page 705. Make a class `Problem` that holds problem-specific parameters: h_0 , r , R , Δt , and T ($[0, T]$ being the time interval for simulation). Our aim is to solve this ODE problem using the `ForwardEuler`, `BackwardEuler`, and `RungeKutta4` classes in the `ODESolver` hierarchy. Read one or more Δt values from the command line, solve the problems for these Δt values, and plot the graphs in the same figure:

```
# Given h_0, r, R
problems = [Problem(h_0, r, R, float(dt)) for dt in sys.argv[1:]]
for problem in problems:
    for method in ForwardEuler, BackwardEuler, RungeKutta4:
        solve(problem, method)
        hold('on')
```

The `solve` function must use the `method` class and information in the `Problem` object to solve the ODE and make a curve plot of $h(t)$ (annotating the legend with the value of `dt` and `method`).

Try out different Δt values between 5 and 50 s. Comment upon the quality of the various methods to compute a correct limiting value of h as Δt is varied. (Hint: negative h values may appear when the problem

is solved numerically, so set $h = 0$ if $h < 0$ before computing \sqrt{h} .)
Name of program file: `tank_ODE_3methods.py`. \diamond

Exercise E.20. *Solve two coupled ODEs for radioactive decay.*

Consider two radioactive substances A and B. The nuclei in substance A decay to form nuclei of type B with a mean lifetime τ_A , while substance B decay to form type A nuclei with a mean lifetime τ_B . Letting u_A and u_B be the fractions of the initial amount of material in substance A and B, respectively, the following system of ODEs governs the evolution of $u_A(t)$ and $u_B(t)$:

$$u'_A = u_B/\tau_B - u_A/\tau_A, \quad (\text{E.68})$$

$$u'_B = u_A/\tau_A - u_B/\tau_B, \quad (\text{E.69})$$

with $u_A(0) = u_B(0) = 1$. As in Exercise E.18, introduce a problem class, which holds the parameters τ_A and τ_B and offers a `__call__` method to compute the right-hand side vector of the ODE system, i.e., $(u_B/\tau_B - u_A/\tau_A, u_A/\tau_A - u_B/\tau_B)$. Solve for u_A and u_B using a subclass in the `ODESolver` hierarchy and the parameter choice $\tau_A = 8$ minutes, $\tau_B = 40$ minutes, and $\Delta t = 10$ seconds. Plot u_A and u_B against time measured in minutes. From the ODE system it follows that the ratio $u_A/u_B \rightarrow \tau_A/\tau_B$ as $t \rightarrow \infty$ (assuming $u'_A = u'_B = 0$ in the limit $t \rightarrow \infty$). Check that the solutions fulfill this requirement (this is a partial verification of the program). Name of program file: `radioactive_decay2.py`. \diamond

Exercise E.21. *Code a 2nd-order Runge-Kutta method; function.*

Implement the 2nd-order Runge-Kutta method specified in formula (E.37). Use a plain function `RungeKutta2` of the type shown in Appendix E.1.2 for the Forward Euler method. Construct a test problem where you know the analytical solution, and plot the difference between the numerical and analytical solution. Name of program file: `RungeKutta2_func.py`. \diamond

Exercise E.22. *Code a 2nd-order Runge-Kutta method; class.*

Make a new subclass `RungeKutta2` in the `ODESolver` hierarchy from Appendix E.2.5 for solving ordinary differential equations with the 2nd-order Runge-Kutta method specified in formula (E.37). Construct a test problem where you know the analytical solution, and plot the difference between the numerical and analytical solution as a function of time. Place the `RungeKutta2` class and the test problem in a separate module (where the superclass `ODESolver` is imported from the `ODESolver` module). Call the test problem from the test block in the module file. Name of program file: `RungeKutta2.py`. \diamond

Exercise E.23. *Make a subclass for Heun's method.*

Implement the numerical method (E.35)–(E.36) in a subclass of `ODESolver`. Place the code in a separate file where the `ODESolver` class

is imported. How can you verify that the implementation is correct?
Name of program file: `Heun.py`. \diamond

Exercise E.24. *Make a subclass for the Midpoint method.*

Implement the Midpoint method specified in formula (E.34) from page 684 in a subclass of `ODESolver`.

Compare in a plot the Midpoint method with the Forward Euler and 4th-order Runge-Kutta methods and the exact solution for the problem $u' = u$, $u(0) = 1$, with 10 steps between 0 and the end time $T = 5$.
Name of program file: `Midpoint.py`. \diamond

Exercise E.25. *Make a subclass for an Adams-Bashforth method.*

Implement the Adams-Bashforth method (E.45) on page 685 in a subclass of `ODESolver`. Use Heun's method (E.36) to compute u_1 .

Compare in a plot the Adams-Bashforth method with the Forward Euler and 4th-order Runge-Kutta methods and the exact solution for the problem $u' = u$, $u(0) = 1$, with 10 steps between 0 and the end time $T = 5$. Name of program file: `AdamsBashforth3.py`. \diamond

Exercise E.26. *Implement the iterated Midpoint method; function.*

Implement the numerical method (E.46)–(E.47) as a function

```
iterated_midpoint_method(f, U0, T, n, N)
```

where `f` is a Python implementation of $f(u, t)$, `U0` is the initial condition $u(0) = U_0$, `T` is the final time of the simulation, `n` is the number of time steps, and `N` is the parameter N in the method (E.46). The `iterated_midpoint_method` should return two arrays: u_0, \dots, u_n and t_0, \dots, t_n . To verify the implementation, calculate by hand u_1 and u_2 when $N = 2$ for the ODE $u' = -2u$, $u(0) = 1$, with $\Delta t = 1/4$. Compare your hand calculations with the results of the program. Thereafter, run the program for the same ODE problem but with $\Delta t = 0.1$ and $T = 2$.
Name of program file: `MidpointIter_func.py`. \diamond

Exercise E.27. *Implement the iterated Midpoint method; class.*

The purpose of this exercise is to implement the numerical method (E.46)–(E.47) in a class like the `ForwardEuler` class from Appendix E.1.7. Create a module containing the class and a test function demonstrating the use:

```
def _application():
    def f(u, t):
        return -2*u

    solver = MidpointIter(f, N=4)
    solver.set_initial_condition(1)
    t_points = numpy.linspace(0, 1.5, 16)
    u, t = solver.solve(t_points)
    from scitools.std import plot
    plot(t, u)
```

Call the `_application` function from the test block in the module file. Also include a `_verify` function which compares the hand calculations

of two time steps (see Exercise E.26) with the results produced by the class. Name of program file: `MidpointIter_class.py`. \diamond

Exercise E.28. *Make a subclass for the iterated Midpoint method.*

Implement the numerical method (E.46)–(E.47) in a subclass of `ODESolver`. The code should reside in a separate file where the `ODESolver` class is imported. One can either fix N or introduce an ϵ and iterate until the change in $|v_q - v_{q-1}|$ is less than ϵ . Allow the constructor to take both N and ϵ as arguments. Compute a new v_q as long as $q \leq N$ or $|v_q - v_{q-1}| > \epsilon$. Let $N = 20$ and $\epsilon = 10^{-6}$ by default. Name of program file: `MidpointIter.py`. \diamond

Exercise E.29. *Study convergence of numerical methods for ODEs.*

The approximation error when solving an ODE numerically is usually of the form $C\Delta t^r$, where C and r are constants that can be estimated from numerical experiments. The constant r , called the *convergence rate*, is of particular interest. Halving Δt halves the error if $r = 1$, but if $r = 3$, halving Δt reduces the error by a factor of 8.

Exercise 9.16 describes a method for estimating r from two consecutive experiments. Make a function

```
ODE_convergence(f, U0, u_e, method, dt=[])
```

that returns a series of estimated r values corresponding to a series of Δt values given as the `dt` list. The argument `f` is a Python implementation of $f(u, t)$ in the ODE $u' = f(u, t)$. The initial condition is $u(0) = U_0$, where U_0 is given as the `U0` argument, `u_e` is the exact solution $u_e(t)$ of the ODE, and `method` is the name of a class in the `ODESolver` hierarchy. The error between the exact solution u_e and the computed solution u_0, u_1, \dots, u_n can be defined as

$$e = \left(\Delta t \sum_{i=0}^n (u_e(t_i) - u_i)^2 \right)^{1/2}.$$

Call the `ODE_convergence` function for some methods you have in the `ODESolver` hierarchy and answers to exercises, and print the estimated r values for each method. Use an ODE problem of your own choice. Name of program file: `ODE_convergence.py`. \diamond

Exercise E.30. *Solve an ODE specified on the command line.*

To solve an ODE, we want to make a program `cmldodesolver.py` which accepts an ODE problem to be specified on the command line. The command-line arguments are `f u0 dt T`, where `f` is the right-hand side $f(u, t)$ specified as a string formula (to be converted to a `StringFunction` object), `u0` is the initial condition, `dt` is the time step, and `T` is the final time of the simulation. A fifth optional argument can be given to specify the class name of the numerical solution method (set any method of choice as default value). A curve plot of the solution

versus time should be produced and stored in a file `plot.png`. Name of program file: `cm1odesolver.py`. \diamond

Exercise E.31. Find the body's position in Exer. E.11.

In Exercise E.11 we compute the velocity $v(t)$. The position of the body, $y(t)$, is related to the velocity by $y'(t) = v(t)$. Extend the program from Exercise E.11 to solve the system

$$\begin{aligned}\frac{dy}{dt} &= v, \\ \frac{dv}{dt} &= -g \left(1 - \frac{\rho}{\rho_b}\right) - \frac{1}{2} C_D \frac{\rho A}{\rho_b V} |v|v.\end{aligned}$$

Name of program file: `body_in_fluid2.py`. \diamond

Exercise E.32. Add the effect of air resistance on a ball.

The differential equations governing the horizontal and vertical motion of a ball subject to gravity and air resistance read³

$$\frac{d^2x}{dt^2} = -\frac{3}{8} C_D \bar{\rho} a^{-1} \sqrt{\left(\frac{dx}{dt}\right)^2 + \left(\frac{dy}{dt}\right)^2} \frac{dx}{dt}, \quad (\text{E.70})$$

$$\frac{d^2y}{dt^2} = -g - \frac{3}{8} C_D \bar{\rho} a^{-1} \sqrt{\left(\frac{dx}{dt}\right)^2 + \left(\frac{dy}{dt}\right)^2} \frac{dy}{dt}, \quad (\text{E.71})$$

where (x, y) is the position of the ball (x is a horizontal measure and y is a vertical measure), g is the acceleration of gravity, $C_D = 0.2$ is a drag coefficient, $\bar{\rho}$ is the ratio of the density of air and the ball, and a is the radius of the ball. The latter two quantities can be taken as 0.017 and 11 cm for a football.

Let the initial condition be $x = y = 0$ (start position in the origin) and

$$dx/dt = v_0 \cos \theta, \quad dy/dt = v_0 \sin \theta,$$

where v_0 is the magnitude of the initial velocity and θ is the angle the velocity makes with the horizontal. For a hard football kick we can set $v_0 = 120$ km/h and take θ as 30 degrees.

Express the two second-order equations above as a system of four first-order equations with four initial conditions. Implement the right-hand side in a problem class where the physical parameters C_D , $\bar{\rho}$, a , v_0 , and θ are stored along with the initial conditions.

Solve the ODE system for $C_D = 0$ (no air resistance) and $C_D = 0.2$, and plot y as a function of x in both cases to illustrate the effect of air resistance. Use the 4-th order Runge-Kutta method. Make sure you express all units in kg, m, s, and radians. Name of program file: `kick2D.py`. \diamond

³ The equations arise by combining the models in Exercises 1.11 and 1.13.

Exercise E.33. *Solve an ODE system for an electric circuit.*

An electric circuit with a resistor, a capacitor, an inductor, and a voltage source can be described by the ODE

$$L \frac{dI}{dt} + RI + \frac{Q}{C} = E(t), \quad (\text{E.72})$$

where LdI/dt is the voltage drop across the inductor, I is the current (measured in amperes, A), L is the inductance (measured in henrys, H), R is the resistance (measured in ohms, Ω), Q is the charge on the capacitor (measured in coulombs, C), C is the capacitance (measured in farads, F), $E(t)$ is the time-variable voltage source (measured in volts, V), and t is time (measured in seconds, s). There is a relation between I and Q :

$$\frac{dQ}{dt} = I. \quad (\text{E.73})$$

Equations (E.72)–(E.73) is a system two ODEs. Solve these for $L = 1$ H, $E(t) = 2 \sin \omega t$ V, $\omega^2 = 3.5 \text{ s}^{-2}$, $C = 0.25$ C, $R = 0.2 \Omega$, $I(0) = 1$ A, and $Q(0) = 1C$. Use the Forward Euler scheme with $\Delta t = 2\pi/(60\omega)$. The solution will, after some time, oscillate with the same period as $E(t)$, a period of $2\pi/\omega$. Simulate 10 periods. (Actually, it turns out that the Forward Euler scheme overestimates the amplitudes of the oscillations. Exercise E.34 compares the Forward Euler scheme with the more accurate 4th-order Runge-Kutta method.) Name of program file: `electric_circuit.py`. \diamond

Exercise E.34. *Compare methods for solving (E.72)–(E.73).*

Consider the system of ODEs in Exercise E.33 for simulating an electric circuit. The purpose now is to compare the Forward Euler scheme with the 4-th order Runge-Kutta method. Make a class `Circuit` for storing the physical parameters of the problem (L , R , C , $E(t)$) as well as the initial conditions ($I(0)$, $Q(0)$). Class `Circuit` should also define the right-hand side of the ODE through a `__call__` method. Create two solver instances, one from the `ForwardEuler` class and one from the `RungeKutta4` class. Solve the ODE system using both methods. Plot the two $I(t)$ solutions for comparison. As you will see, the Forward Euler scheme overestimates the amplitudes significantly, compared with the more accurate 4th-order Runge-Kutta method. Name of program file: `electric_circuit2.py`. \diamond

Exercise E.35. *Simulate the spreading of a disease.*

We shall in this exercise model epidemiological diseases such as measles or swine flu. Suppose we have three categories of people: susceptibles (S) who can get the disease, infected (I) who has developed the disease and who can infect susceptibles, and recovered (R) who have recovered from the disease and become immune. Let $S(t)$, $I(t)$, and $R(t)$ be the number of people in category S, I, and R, respectively.

We have that $S + I + R = N$, where N is the size of the population, assumed constant here for simplicity.

When people mix in the population there are SI possible pairs of susceptibles and infected, and a certain fraction βSI per time interval does meet with the result that the infected “successfully” infects the susceptible. During a time interval Δt , $\beta SI \Delta t$ get infected and move from the S to the I category:

$$S(t + \Delta t) = S(t) - \beta SI \Delta t.$$

We divide by Δt and let $\Delta \rightarrow 0$ to get the differential equation

$$S'(t) = -\beta SI. \quad (\text{E.74})$$

A fraction νI of the infected will per time unit recover from the disease. In a time Δt , $\nu I \Delta t$ recover and move from the I to the R category. The quantity $1/\nu$ typically reflects the duration of the disease. In the same time interval, $\beta SI \Delta t$ come from the S to the I category. The accounting for the I category therefore becomes

$$I(t + \Delta t) = I(t) + \beta SI \Delta t - \nu I \Delta t,$$

which in the limit $\Delta t \rightarrow \infty$ becomes the differential equation

$$I'(t) = \beta SI - \nu I. \quad (\text{E.75})$$

Finally, the R category gets contributions from the I category:

$$R(t + \Delta t) = R(t) + \nu I \Delta t.$$

The corresponding ODE for R reads

$$R'(t) = \nu I. \quad (\text{E.76})$$

In case the recovered do not become immune, we do not need the recovered category, since the recovered go directly out of the I category to the S category again. This gives a contribution νI to the equation for S and we end up with the S – I system (C.32)–(C.33) from Appendix C.5.

The system (E.74)–(E.76) is known as a SIR model in epidemiology (which is the name of the scientific field studying the spreading of epidemic diseases).

Solve the equations in the SIR model by any numerical method of your choice. Show from the equations that $S' + I' + R' = 0$, which means that $S + I + R$ must be constant. This can be used to test the program. Let $S(0) = 1500$, $I(0) = I_0$, and $R(0) = 0$. Set $\nu = 0.1$, $I_0 = 1$, $\Delta t = 0.5$, and $t \in [0, 60]$. Time t here counts days. Make a plot corresponding to $\beta = 0.0005$. Certain precautions, like staying inside,

will reduce β . Try $\beta = 0.0001$ and watch the effect on $S(t)$. Name of program file: SIR.py. \diamond

Exercise E.36. *Make a more flexible code in Exer. E.35.*

The parameters ν and β in the SIR model in Exercise E.35 can be constants or functions of time. Now we shall make an implementation of the $f(u, t)$ function specifying the ODE system such that ν and β can be given as either a constant or a Python function. Introduce a class for $f(u, t)$, with the following code sketch:

```
class Problem:
    def __init__(self, nu, beta, S0, IO, RO, T):
        """
        nu, beta: parameters in the ODE system
        S0, IO, RO: initial values
        T: simulation for t in [0,T]
        """
        if isinstance(nu, (float,int)): # number?
            self.nu = lambda t: nu      # wrap as function
        elif callable(nu):
            self.nu = nu

        # same for beta and self.beta
        ...

        # store the other parameters

    def __call__(self, u, t):
        """Right-hand side function of the ODE system."""
        S, I, R = u
        return [-self.beta(t)*S*I,      # S equation
                ...,                    # I equation
                -self.nu(t)*I]         # R equation

# Example:
problem = Problem(beta=lambda t: 0.0005 if t <= 12 else 0.0001,
                  nu=0.1, S0=1500, IO=1)
solver = ODESolver.ForwardEuler(problem.f)
```

Write the complete code for class `Problem` based on the sketch of ideas above. The ν parameter is usually not varying with time as $1/\nu$ is a characteristic size of the period a person is sick, but introduction of new medicine during the disease might change the picture such that time dependence becomes relevant.

We can also make a class `Solver` for solving the problem (see Appendix E.2.8 for similar examples):

```
class Solver:
    def __init__(self, problem, dt):
        self.problem, self.dt = problem, dt

    def solve(self, method=ODESolver.RungeKutta4):
        self.solver = method(problem)
        ic = [self.problem.S0, self.problem.IO, self.problem.RO]
        self.solver.set_initial_condition(ic)
        n = int(round(self.problem.T/float(self.dt)))
        t = np.linspace(0, self.problem.T, n+1)
        u, self.t = self.solver.solve(t)
        self.S, self.I, self.R = u[:,0], u[:,1], u[:,2]
```

```
def plot(self):
    # plot S(t), I(t), and R(t)
```

After the breakout of a disease, authorities often start campaigns for decreasing the spreading of the disease. Suppose a massive campaign telling people to wash their hands more frequently is launched, with the effect that β is significantly reduced after a some days. For the specific case simulated in Exercise [E.35](#), let

$$\beta(t) = \begin{cases} 0.0005, & 0 \leq t \leq 12, \\ 0.0001, & t > 12 \end{cases}$$

Simulate this scenario with the `Problem` and `Solver` classes. Report the maximum number of infected people and compare it to the case where $\beta(t) = 0.0005$. Name of program file: `SIR_class.py`. \diamond

Exercise E.37. *Introduce vaccination in Exer. [E.35](#).*

We shall now extend the SIR model in Exercise [E.35](#) with a vaccination program. If a fraction p of the susceptibles per time unit is being vaccinated, and we say that the vaccination is 100% effective, $pS\Delta t$ individuals will be removed from the S category in a time interval Δt . We place the vaccinated people in a new category V. The equations for S and V becomes

$$S' = -\beta SI - pS, \quad (\text{E.77})$$

$$V' = pS. \quad (\text{E.78})$$

The equations for I and R are not affected. The initial condition for V can be taken as $V(0) = 0$. The resulting model is named SIRV.

Make a program for computing $S(t)$, $I(t)$, $R(t)$, and $V(t)$. Try the same parameters as in Exercise [E.35](#) in combination with $p = 0.1$. Watch the effect of vaccination on the maximum number of infected. Name of program file: `SIRV.py`. \diamond

Exercise E.38. *Introduce a vaccination campaign in Exer. [E.37](#).*

Let the vaccination campaign in Exercise [E.37](#) start 6 days after the outbreak of the disease and let it last for 10 days,

$$p(t) = \begin{cases} 0.1, & 6 \leq t \leq 15, \\ 0, & \text{otherwise} \end{cases}$$

Plot the corresponding solutions $S(t)$, $I(t)$, $R(t)$, and $V(t)$. (It is clearly advantageous to have the SIRV model implemented as an extension to the classes in Exercise [E.36](#).) Name of program file: `SIRV_varying_p.py`. \diamond

Exercise E.39. *Find optimal vaccination period in Exer. [E.38](#).*

Let the vaccination campaign in Exercise [E.38](#) last for V_T days:

$$p(t) = \begin{cases} 0.1, & 6 \leq t \leq 6 + V_T, \\ 0, & \text{otherwise} \end{cases}$$

Compute the maximum number of infected people, $\max_t I(t)$, as a function of $V_T \in [0, 31]$. Plot this function. Determine the optimal V_T , i.e., the smallest vaccination period V_T such that increasing V_T has negligible effect on the maximum number of infected people. Name of program file: `SIRV_optimal_duration.py`. \diamond

Exercise E.40. *Simulate human–zombie interaction.*

Suppose the human population is attacked by zombies. This is quite a common happening in movies, and the “zombification” of humans acts much like the spreading of a disease. Let us make a differential equation model, inspired by the SIR model from Exercise E.35, to simulate how humans and zombies interact.

We introduce four categories of individuals:

1. S: susceptible humans who can become zombies.
2. I: infected humans, being bitten by zombies.
3. Z: zombies.
4. R: removed individuals, either conquered zombies or dead humans.

The corresponding functions counting how many individuals we have in each category are named $S(t)$, $I(t)$, $Z(t)$, and $R(t)$, respectively.

The type of zombies considered here is inspired by the standard for modern zombies set by the classic movie *The Night of the Living Dead*, by George A. Romero from 1968. Only a small extension of the SIR model is necessary to model the effect of human–zombie interaction mathematically. A fraction of the human susceptibles is getting bitten by zombies and moves to the infected category. A fraction of the infected is then turned into zombies. On the other hand, humans can conquer zombies.

Now we shall precisely set up all the dynamic features of the human–zombie populations we aim to model. Changes in the S category are due to three effects:

1. Susceptibles are infected by zombies, modeled by a term $-\Delta t \beta S Z$, similar to the S-I interaction in the SIR model.
2. Susceptibles die naturally or get killed and therefore enter the removed category. If the probability that one susceptible dies during a unit time interval is δ_S , the total expected number of deaths in a time interval Δt becomes $\Delta t \delta_S S$.
3. We also allow new humans to enter the area with zombies, as this effect may be necessary to successfully run a war on zombies. The number of new individuals in the S category arriving per time unit is denoted by Σ , giving an increase in $S(t)$ by $\Delta t \Sigma$ during a time Δt .

We could also add newborns to the S category, but we simply skip this effect since it will not be significant over time scales of a few days.

The balance of the S category is then

$$S' = \Sigma - \beta SZ - \delta_S S,$$

in the limit $\Delta t \rightarrow 0$.

The infected category gets a contribution $\Delta t \beta SZ$ from the S category, but loses individuals to the Z and R category. That is, some infected are turned into zombies, while others die. Movies reveal that infected may commit suicide or that others (susceptibles) may kill them. Let δ_I be the probability of being killed in a unit time interval. During time Δt , a total of $\delta_I \Delta t I$ will die and hence be transferred to the removed category. The probability that a single infected is turned into a zombie during a unit time interval is denoted by ρ , so that a total of $\Delta t \rho I$ individuals are lost from the I to the Z category in time Δt . The accounting in the I category becomes

$$I' = \beta SZ - \rho I - \delta_I I.$$

The zombie category gains $-\Delta t \rho I$ individuals from the I category. We disregard the effect that any removed individual can turn into a zombie again, as we consider that effect as pure magic beyond reasonable behavior, at least according to what is observed in the Romero movie tradition. A fundamental feature in zombie movies is that humans can conquer zombies. Here we consider zombie killing in a “man-to-man” human–zombie fight. This interaction resembles the nature of zombification (or the susceptible-infective interaction in the SIR model) and can be modeled by a loss $-\alpha SZ$ for some parameter α with an interpretation similar to that of β . The equation for Z then becomes

$$Z' = \rho I - \alpha SZ.$$

The accounting in the R category consists of a gain $\delta_S S$ of natural deaths from the S category, a gain $\delta_I I$ from the I category, and a gain αSZ from defeated zombies:

$$R' = \delta_S S + \delta_I I + \alpha SZ.$$

The complete SIZR model for human–zombie interaction can be summarized as

$$S' = \Sigma - \beta SZ - \delta_S S, \tag{E.79}$$

$$I' = \beta SZ - \rho I - \delta_I I, \tag{E.80}$$

$$Z' = \rho I - \alpha SZ, \tag{E.81}$$

$$R' = \delta_S S + \delta_I I + \alpha SZ. \tag{E.82}$$

The interpretations of the parameters are as follows:

- Σ : the number of new humans brought into the zombified area per unit time.
- β : the probability that a theoretically possible human-zombie pair actually meets physically, during a unit time interval, with the result that the human is infected.
- δ_S : the probability that a susceptible human is killed or dies, in a unit time interval.
- δ_I : the probability that an infected human is killed or dies, in a unit time interval.
- ρ : the probability that an infected human is turned into a zombie, during a unit time interval.
- α : the probability that, during a unit time interval, a theoretically possible human-zombie pair fights and the human kills the zombie.

Note that probabilities per unit time do not necessarily lie in the interval $[0, 1]$. The real probability, lying between 0 and 1, arises after multiplication by the time interval of interest.

Implement the SIZR model with a `Problem` and `Solver` class as explained in Exercise E.36, allowing parameters to vary in time. The time variation is essential to make a realistic model that can mimic what happens in movies. It becomes necessary (cf. Exercise E.41) to work with piecewise constant functions in time, for instance from `scitools.std` (or Exercise 3.27):

```
from scitools.std import PiecewiseConstant

# Define f(t) as 1.5 in [0,3], 0.1 in [3,4] and 1 in [4,7]
f = PiecewiseConstant(domain=[0, 7],
                      data=[(0, 1.5), (3, 0.1), (4, 1)])
```

Test the implementation with the following data: $\beta = 0.0012$, $\alpha = 0.0016$, $\delta_I = 0.014$, $\Sigma = 2$, $\rho = 1$, $S(0) = 10$, $Z(0) = 100$, $I(0)$, $R(0) = 0$, and simulation time $T = 24$ hours. All other parameters can be set to zero. These values are estimated from the hysterical phase of the movie *The Night of the Living Dead*. The time unit is hours. Plot the S , I , Z , and R quantities. Name of program file: `SIZR.py`. \diamond

Exercise E.41. *Simulate an entire zombie movie.*

The movie *The Night of the Living Dead* has three phases:

1. The initial phase, lasting for (say) 4 hours, where two humans meet one zombie and of the humans get infected. A rough (and uncertain) estimation of parameters in this phase, taking into account dynamics not shown in the movie, yet necessary to establish a more realistic evolution of the S and Z categories later in the movie, is $\Sigma = 20$, $\beta = 0.03$, $\rho = 1$, $S(0) = 60$, and $Z(0) = 1$. All other parameters are taken as zero when not specified.

2. The hysterical phase, when the zombie treat is evident. This phase lasts for 24 hours, and relevant parameters can be taken as $\beta = 0.0012$, $\alpha = 0.0016$, $\delta_I = 0.014$, $\Sigma = 2$, $\rho = 1$.
3. The counter attack by humans, estimated to last for 5 hours, with parameters $\alpha = 0.006$, $\beta = 0$ (humans no longer get infected), $\delta_S = 0.0067$, $\rho = 1$.

Use the program from Exercise E.40 to simulate all three phases of the movie. Name of program file: `Night_of_the_Living_Dead.py`. \diamond

Exercise E.42. *Simulate a war on zombies.*

A war on zombies can be implemented through large-scale effective attacks. A possible model is to increase α in the SIZR model from Exercise E.40 by some amount $\omega(t)$, where $\omega(t)$ varies in time to model strong attacks at some distinct points of time $T_1 < T_2 < \dots < T_m$. Around these t values we want ω to have a large value, while in between the attacks ω is small. One possible mathematical function with this behavior is a sum of Gaussian functions:

$$\omega(t) = a \sum_{i=0}^m \exp\left(\frac{1}{2} \left(\frac{t - T_i}{\sigma}\right)^2\right), \quad (\text{E.83})$$

where a measures the strength of the attacks (the maximum value of $\omega(t)$) and σ measures the length of the attacks, which should be much less than the time between the points of attack: typically, 4σ measures the length of an attack, and we must have $4\sigma \ll T_i - T_{i-1}$. We should choose a significantly larger than α to make the attacks in the war on zombies much stronger than the “man-to-man” killing of zombies.

Modify the model and the implementation from Exercise E.40 to include a war on zombies. As a demonstration, we start out with 50 humans and 3 zombies, and $\beta = 0.0625$ as estimated from *The Night of The Living Dead* movie. These values lead to a rapid zombification. We assume there are some small resistances against zombies from the humans: $\alpha = 0.2\beta$. However, the humans implement three strong attacks, $a = 50\alpha$, at 5, 10, and 18 hours after zombification starts. The attacks last for about 2 hours ($\sigma = 0.5$). Add this effect to the simulation in Exercise E.41 and see if such attacks are sufficient to save mankind in this particular case. Use $\rho = 1$ as before and set non-specified parameters to zero. Name of program file: `war_on_zombies.py`. \diamond

Exercise E.43. *Explore predator-prey population interactions.*

Suppose we have two species in an environment: a predator and a prey. How will the two populations interact and change with time? A system of ordinary differential equations can give insight into this question. Let $x(t)$ and $y(t)$ be the size of the prey and the predator populations, respectively. In the absence of a predator, the population of the prey will follow the ODE derived in Appendix C.2:

$$\frac{dx}{dt} = rx,$$

with $r > 0$, assuming there are enough resources for exponential growth. Similarly, in the absence of prey, the predator population will just experience a death rate $m > 0$:

$$\frac{dy}{dt} = -my.$$

In the presence of the predator, the prey population will experience a reduction in the growth proportional to xy . The number of interactions (meetings) between x and y numbers of animals is xy , and in a certain fraction of these interactions the predator eats the prey. The predator population will correspondingly experience a growth in the population because of the xy interactions with the prey population. The adjusted growth of both populations can now be expressed as

$$\frac{dx}{dt} = rx - axy, \tag{E.84}$$

$$\frac{dy}{dt} = -my + bxy, \tag{E.85}$$

for positive constants r , m , a , and b . Solve this system and plot $x(t)$ and $y(t)$ for $r = m = 1$, $a = 0.3$, $b = 0.2$, $x(0) = 1$, and $y(0) = 1$, $t \in [0, 20]$. Try to explain the dynamics of the population growth you observe. Experiment with other values of a and b . Name of program file: `predator_prey.py`. \diamond

Exercise E.44. *Formulate a 2nd-order ODE as a system.*

In this and subsequent exercises we shall deal with the following second-order ordinary differential equation with two initial conditions:

$$m\ddot{u} + f(\dot{u}) + s(u) = F(t), \quad t > 0, \quad u(0) = U_0, \quad \dot{u}(0) = V_0. \tag{E.86}$$

The notation \dot{u} and \ddot{u} means $u'(t)$ and $u''(t)$, respectively. Write (E.86) as a system of two first-order differential equations. Also set up the initial condition for this system.

Physical Applications. Equation (E.86) has a wide range of applications throughout science and engineering. A primary application is damped spring systems in, e.g., cars and bicycles: u is the vertical displacement of the spring system attached to a wheel; \dot{u} is then the corresponding velocity; $F(t)$ resembles a bumpy road; $s(u)$ represents the force from the spring; and $f(\dot{u})$ models the damping force (friction) in the spring system. For this particular application f and s will normally be linear functions of their arguments: $f(\dot{u}) = \beta\dot{u}$ and $s(u) = ku$, where k is a spring constant and β some parameter describing viscous damping.

Equation (E.86) can also be used to describe the motions of a moored ship or oil platform in waves: the moorings act as a nonlinear spring $s(u)$; $F(t)$ represents environmental excitation from waves, wind, and current; $f(\dot{u})$ models damping of the motion; and u is the one-dimensional displacement of the ship or platform.

Oscillations of a pendulum can be described by (E.86): u is the angle the pendulum makes with the vertical; $s(u) = (mg/L) \sin(u)$, where L is the length of the pendulum, m is the mass, and g is the acceleration of gravity; $f(\dot{u}) = \beta|\dot{u}|\dot{u}$ models air resistance (with β being some suitable constant, see Exercises 1.11 and E.48); and $F(t)$ might be some motion of the top point of the pendulum.

Another application is electric circuits with $u(t)$ as the charge, $m = L$ as the inductance, $f(\dot{u}) = R\dot{u}$ as the voltage drop across a resistor R , $s(u) = u/C$ as the voltage drop across a capacitor C , and $F(t)$ as an electromotive force (supplied by a battery or generator).

Furthermore, Equation (E.86) can act as a simplified model of many other oscillating systems: aircraft wings, lasers, loudspeakers, microphones, tuning forks, guitar strings, ultrasound imaging, voice, tides, the El Niño phenomenon, climate changes – to mention some.

We remark that (E.86) is a possibly nonlinear generalization of Equation (D.8) explained in Appendix D.1.3. The case in Appendix D corresponds to the special choice of $f(\dot{u})$ proportional to the velocity \dot{u} , $s(u)$ proportional to the displacement u , and $F(t)$ as the acceleration \ddot{w} of the plate and the action of the gravity force. \diamond

Exercise E.45. Solve the system in Exer. E.44 in a special case.

Make a function

```
def rhs(u, t):
    ...
```

for returning a list with two elements with the two right-hand side expressions in the first-order differential equation system from Exercise E.44. As usual, the u argument is an array or list with the two solution components $u[0]$ and $u[1]$ at some time t . Inside rhs , assume that you have access to three global Python functions `friction(dudt)`, `spring(u)`, and `external(t)` for evaluating $f(\dot{u})$, $s(u)$, and $F(t)$, respectively.

Test the `rhs` function in combination with the functions $f(\dot{u}) = 0$, $F(t) = 0$, $s(u) = u$, and the choice $m = 1$. The differential equation then reads $\ddot{u} + u = 0$. With initial conditions $u(0) = 1$ and $\dot{u}(0) = 0$, one can show that the solution is given by $u(t) = \cos(t)$. Apply three numerical methods: the 4th-order Runge-Kutta method and the Forward Euler method from the `ODESolver` module developed in Appendix E.2.5, as well as the 2nd-order Runge-Kutta method developed in Exercise E.22. Use a time step $\Delta t = \pi/20$.

Plot $u(t)$ and $\dot{u}(t)$ versus t together with the exact solutions. Also make a plot of \dot{u} versus u (plot($u[:,0]$, $u[:,1]$) if u is the array returned from the solver's `solve` method). In the latter case, the exact plot should be a circle⁴, but the ForwardEuler method results in a spiral. Investigate how the spiral develops as Δt is reduced.

The kinetic energy K of the motion is given by $\frac{1}{2}m\dot{u}^2$, and the potential energy P (stored in the spring) is given by the work done by the spring force: $P = \int_0^u s(v)dv = \frac{1}{2}u^2$. Make a plot with K and P as functions of time for both the 4th-order Runge-Kutta method and the Forward Euler method, for the same physical problem described above. In this test case, the sum of the kinetic and potential energy should be constant. Compute this constant analytically and plot it together with the sum $K + P$ as calculated by the 4th-order Runge-Kutta method and the Forward Euler method.

Name of program file: `oscillator_v1.py`. ◇

Exercise E.46. *Make a tool for analyzing oscillatory solutions.*

The solution $u(t)$ of the equation (E.86) often exhibits an oscillatory behavior (for the test problem in Exercise E.45 we have that $u(t) = \cos t$). It is then of interest to find the wavelength of the oscillations. The purpose of this exercise is to find and visualize the distance between peaks in a numerical representation of a continuous function.

Given an array (y_0, \dots, y_{n-1}) representing a function $y(t)$ sampled at various points t_0, \dots, t_{n-1} . A local maximum of $y(t)$ occurs at $t = t_k$ if $y_{k-1} < y_k > y_{k+1}$. Similarly, a local minimum of $y(t)$ occurs at $t = t_k$ if $y_{k-1} > y_k < y_{k+1}$. By iterating over the y_1, \dots, y_{n-2} values and making the two tests, one can collect local maxima and minima as (t_k, y_k) pairs. Make a function `minmax(t, y)` which returns two lists, `minima` and `maxima`, where each list holds pairs (2-tuples) of t and y values of local minima or maxima. Ensure that the t value increases from one pair to the next. The arguments `t` and `y` in `minmax` hold the coordinates t_0, \dots, t_{n-1} and y_0, \dots, y_{n-1} , respectively.

Make another function `wavelength(peaks)` which takes a list `peaks` of 2-tuples with t and y values for local minima or maxima as argument and returns an array of distances between consecutive t values, i.e., the distances between the peaks. These distances reflect the local wavelength of the computed y function. More precisely, the first element in the returned array is `peaks[1][0]-peaks[0][0]`, the next element is `peaks[2][0]-peaks[1][0]`, and so forth.

Test the `minmax` and `wavelength` functions on y values generated by $y = e^{t/4} \cos(2t)$ and $y = e^{-t/4} \cos(t^2/5)$ for $t \in [0, 4\pi]$. Plot the $y(t)$ curve in each case, and mark the local minima and maxima computed by `minmax` with circles and boxes, respectively. Make a separate plot with the array returned from the `wavelength` function (just plot the

⁴ The points on the curve are $(\cos t, \sin t)$, which all lie on a circle as t is varied.

array against its indices - the point is to see if the wavelength varies or not). Plot only the wavelengths corresponding to maxima.

Make a module with the `minmax` and `wavelength` function, and let the test block perform the tests specified above. Name of program file: `wavelength.py`. \diamond

Exercise E.47. *Enhance the code from Exer. E.45.*

The user-chosen functions f , s , and F in Exercise E.45 must be coded with particular names. It is then difficult to have several functions for $s(u)$ and experiment with these. A much more flexible code arises if we adopt the ideas of a problem and a solver class as explained in Appendix E.2.8. Specifically, we shall here make use of class `Problem3` in Appendix E.2.8 to store information about $f(\dot{u})$, $s(u)$, $F(t)$, $u(0)$, $\dot{u}(0)$, m , T , and the exact solution (if available). The solver class can store parameters related to the numerical quality of the solution, i.e., Δt and the name of the solver class in the `ODESolver` hierarchy. In addition we will make a visualizer class for producing plots of various kinds.

We want all parameters to be set on the command line, but also have sensible default values. As in Appendix E.2.8, the `argparse` module is used to read data from the command line. Class `Problem` can be sketched as follows:

```
class Problem:
    def define_command_line_arguments(self, parser):
        """Add arguments to parser (argparse.ArgumentParser)."""

        parser.add_argument(
            '--friction', type=func_dudt, default='0',
            help='friction function f(dudt)',
            metavar='<function expression>')
        parser.add_argument(
            '--spring', type=func_u, default='u',
            help='spring function s(u)',
            metavar='<function expression>')
        parser.add_argument(
            '--external', type=func_t, default='0',
            help='external force function F(t)',
            metavar='<function expression>')
        parser.add_argument(
            '--u_exact', type=func_t_vec, default='0',
            help='exact solution u(t) (0 or None: now known)',
            metavar='<function expression>')
        parser.add_argument(
            '--m', type=evalcmlarg, default=1.0, help='mass',
            type=float, metavar='mass')
        ...
    return parser

    def set(self, args):
        """Initialize parameters from the command line."""
        self.friction = args.friction
        self.spring = args.spring
        self.m = args.m
        ...

    def __call__(self, u, t):
```

```

        """Define the right-hand side in the ODE system."""
        m, f, s, F = \
            self.m, self.friction, self.spring, self.external
        ...

```

Several functions are specified as the type argument to `parser.add_argument` for turning strings into proper objects, in particular `StringFunction` objects with different independent variables:

```

def evalcmlarg(text):
    return eval(text)

def func_dudt(text):
    return StringFunction(text, independent_variable='dudt')

def func_u(text):
    return StringFunction(text, independent_variable='u')

def func_t(text):
    return StringFunction(text, independent_variable='t')

def func_t_vec(text):
    if text == 'None' or text == '0':
        return None
    else:
        f = StringFunction(text, independent_variable='t')
        f.vectorize(globals())
        return f

```

The use of `evalcmlarg` is essential: this function runs the strings from the command line through `eval`, which means that we can use mathematical formulas like `-T4*pi`.

Class `Solver` is relatively much shorter than class `Problem`:

```

class Solver:
    def __init__(self, problem):
        self.problem = problem

    def define_command_line_arguments(self, parser):
        """Add arguments to parser (argparse.ArgumentParser)."""
        # add --dt and --method
        ...
        return parser

    def set(self, args):
        self.dt = args.dt
        self.n = int(round(self.problem.T/self.dt))
        self.solver = eval(args.method)

    def solve(self):
        self.solver = self.method(self.problem)
        ic = [self.problem.initial_u, self.problem.initial_dudt]
        self.solver.set_initial_condition(ic)
        time_points = linspace(0, self.problem.T, self.n+1)
        self.u, self.t = self.solver.solve(time_points)

```

The `Visualizer` class holds references to a `Problem` and `Solver` instance and creates plots. The user can specify plots in an interactive dialog in the terminal window. Inside a loop, the user is repeatedly asked to specify a plot until the user responds with `quit`. The specification of a plot can be one of the words `u`, `dudt`, `dudt-u`, `K`, and

wavelength which means a plot of $u(t)$ versus t , $\dot{u}(t)$ versus t , \dot{u} versus u , $K (= \frac{1}{2}m\dot{u}^2, \text{ kinetic energy})$ versus t , and u 's wavelength versus its indices, respectively. The wavelength can be computed from the local maxima of u as explained in Exercise E.46.

A sketch of class Visualizer is given next:

```
class Visualizer:
    def __init__(self, problem, solver):
        self.problem = problem
        self.solver = solver

    def define_command_line_arguments(self, parser):
        parser.add_argument(
            '--plot', type=str, default='u dudt',
            help='specification of types of plots',
            metavar='<space separated list of plot types>')
        return parser

    def set(self, args):
        plot_spec = args.plot
        self.plots = plot_spec.split()

    def visualize(self):
        t = self.solver.t # short form
        u, dudt = self.solver.u[:,0], self.solver.u[:,1]

        # Tag all plots with numerical and physical input values
        title = 'solver=%s, dt=%g, m=%g' % \
            (self.solver.method, self.solver.dt, self.problem.m)
        # Can easily get the formula for friction, spring and force
        # if these are string formulas.
        if isinstance(self.problem.friction, StringFunction):
            title += ' f=%s' % str(self.problem.friction)
        if isinstance(self.problem.spring, StringFunction):
            title += ' s=%s' % str(self.problem.spring)
        if isinstance(self.problem.external, StringFunction):
            title += ' F=%s' % str(self.problem.external)

        plot_type = ''
        while plot_type != 'quit':
            plot_type = raw_input('Specify a plot: ')
            figure()
            if plot_type == 'u':
                # Plot u vs t
                if self.problem.u_exact is not None:
                    hold('on')
                # Plot self.problem.u_exact vs t
                show()
                savefig('tmp_u.eps')
            elif plot_type == 'dudt':
                ...
```

Make a complete implementation of the three proposed classes. Also make a main function that (i) creates a problem, solver, and visualizer, (ii) calls the functions to define command-line arguments in each of them, (iii) reads the command line, (iv) passes on the `args` from the reading of the command line to the problem, solver, and visualizer classes, (v) calls the solver, and (vi) calls the visualizer's `visualize` method to create plots. Collect the classes and functions in a module `oscillator`, which has a call to `main` in the test block.

The first task from Exercises [E.45](#) can now be run as

```
Terminal
```

```
oscillator.py --method ForwardEuler --u_exact "cos(t)" \
  --dt "pi/20" --T "5*pi"
```

The other tasks from Exercises [E.45](#) can be tested similarly.

Explore some of the possibilities of specifying several functions on the command line:

```
Terminal
```

```
oscillator.py --method RungeKutta4 --friction "0.1*dudt" \
  --external "sin(0.5*t)" --dt "pi/80" \
  --T "40*pi" --m 10

oscillator.py --method RungeKutta4 --friction "0.8*dudt" \
  --external "sin(0.5*t)" --dt "pi/80" \
  --T "120*pi" --m 50
```

Name of program file: `oscillator.py`. ◇

Exercise E.48. Allow flexible choice of functions in Exer. [E.47](#).

Some typical choices of $f(\dot{u})$, $s(u)$, and $F(t)$ in [\(E.86\)](#) are listed below:

1. Linear friction force (low velocities): $f(\dot{u}) = 6\pi\mu R\dot{u}$ (Stokes drag), where R is the radius of a spherical approximation to the body's geometry, and μ is the viscosity of the surrounding fluid.
2. Quadratic friction force (high velocities): $f(\dot{u}) = \frac{1}{2}C_D\rho A|\dot{u}|\dot{u}$, see Exercise 1.11 for explanation of symbols.
3. Linear spring force: $s(u) = ku$, where k is a spring constant.
4. Sinusoidal spring force: $s(u) = k\sin u$, where k is a constant.
5. Cubic spring force: $s(u) = k(u - \frac{1}{6}u^3)$, where k is a spring constant.
6. Sinusoidal external force: $F(t) = F_0 + A\sin\omega t$, where F_0 is the mean value of the force, A is the amplitude, and ω is the frequency.
7. "Bump" force: $F(t) = H(t - t_1)(1 - H(t - t_2))F_0$, where $H(t)$ is the Heaviside function from Exercise 3.24, t_1 and t_2 are two given time points, and F_0 is the size of the force. This $F(t)$ is zero for $t < t_1$ and $t > t_2$, and F_0 for $t \in [t_1, t_2]$.
8. Random force 1: $F(t) = F_0 + A \cdot U(t; B)$, where F_0 and A are constants, and $U(t; B)$ denotes a function whose value at time t is random and uniformly distributed in the interval $[-B, B]$.
9. Random force 2: $F(t) = F_0 + A \cdot N(t; \mu, \sigma)$, where F_0 and A are constants, and $N(t; \mu, \sigma)$ denotes a function whose value at time t is random, Gaussian distributed number with mean μ and standard deviation σ .

Make a module `functions` where each of the choices above are implemented as a class with a `__call__` special method. Also add a class `Zero` for a function whose value is always zero. It is natural that the parameters in a function are set as arguments to the constructor. The different

classes for spring functions can all have a common base class holding the k parameter as attribute. Name of program file: `functions.py`. \diamond

Exercise E.49. Use the modules from Exer. E.47 and E.48.

The purpose of this exercise is to demonstrate the use of the classes from Exercise E.48 to solve problems described by (E.86).

With a lot of models for $f(\dot{u})$, $s(u)$, and $F(t)$ available as classes in `functions.py`, the initialization of `self.friction`, `self.spring`, etc., from the command line does not work, because we assume simple string formulas on the command line. Now we want to write things like `-spring 'LinearSpring(1.0)'`. There is a quite simple remedy: replace all the special conversion functions to `StringFunction` objects by `evalcmlarg` in the type specifications in the `parser.add_argument` calls. If a `from functions import *` is also performed in the `oscillator.py` file, a simple `eval` will turn strings like `'LinearSpring(1.0)'` into living objects.

However, we shall here follow a simpler approach, namely dropping initializing parameters on the command line and instead set them directly in the code. Here is an example:

```
problem = Problem()
problem.m = 1.0
k = 1.2
problem.spring = CubicSpring(k)
problem.friction = Zero()
problem.T = 8*pi/sqrt(k)
...
```

This is the simplest way of making use of the objects in the `functions` module.

Note that the `set` method in classes `Solver` and `Visualizer` is unaffected by the new objects from the `functions` module, so flexible initialization via command-line arguments works as before for `-dt`, `-method`, and `plot`. One may also dare to call the `set` method in the problem object to set parameters like `m`, `initial_u`, etc., or one can choose the safer approach of not calling `set` but initialize all attributes explicitly in the user's code.

Make a new file say `oscillator_test.py` where you import class `Problem`, `Sover`, and `Visualizer`, plus all classes from the `functions` module. Provide a `main1` function for solving the following problem: $m = 1$, $u(0) = 1$, $\dot{u}(0) = 0$, no friction (use class `Zero`), no external forcing (class `Zero`), a linear spring $s(u) = u$, $\Delta t = \pi/20$, $T = 8\pi$, and exact $u(t) = \cos(t)$. Use the Forward Euler method.

Then make another function `main2` for the case with $m = 5$, $u(0) = 1$, $\dot{u}(0) = 0$, linear friction $f(\dot{u}) = 0.1\dot{u}$, $s(u) = u$, $F(t) = \sin(\frac{1}{2}t)$, $\Delta t = \pi/80$, $T = 60\pi$, and no knowledge of an exact solution. Use the 4-th order Runge-Kutta method.

Let a test block use the first command-line argument to indicate a call to `main1` or `main2`. Name of program file: `oscillator_test.py`. \diamond

Exercise E.50. *Model the economy of fishing.*

A population of fish is governed by the differential equation

$$\frac{dx}{dt} = \frac{1}{10}x \left(1 - \frac{x}{100} \right) - h, \quad x(0) = 500, \quad (\text{E.87})$$

where $x(t)$ is the size of the population at time t and h is the harvest.

- (a) Assume $h = 0$. Find an exact solution for $x(t)$. For which value of t is $\frac{dx}{dt}$ largest? For which value of t is $\frac{1}{x} \frac{dx}{dt}$ largest?
- (b) Solve the differential equation (E.87) by the Forward Euler method. Plot the numerical and exact solution in the same plot.
- (c) Suppose the harvest h depends on the fishers' efforts, E , in the following way: $h = qxE$, with q as a constant. Set $q = 0.1$ and assume E is constant. Show the effect of E on $x(t)$ by plotting several curves, corresponding to different E values, in the same figure.
- (d) The fishers' total revenue is given by $\pi = ph - \frac{c}{2}E^2$, where p is a constant. In the literature about the economy of fisheries, one is often interested in how a fishery will develop in the case the harvest is not regulated. Then new fishers will appear as long as there is money to earn ($\pi > 0$). It can (for simplicity) be reasonable to model the dependence of E on π as

$$\frac{dE}{dt} = \gamma\pi, \quad (\text{E.88})$$

where γ is a constant. Solve the system of differential equations for $x(t)$ and $E(t)$ by the 4th-order Runge-Kutta method, and plot the curve with points $(x(t), E(t))$ in the two cases $\gamma = 1/2$ and $\gamma \rightarrow \infty$. Choose $c = 0.3$, $p = 10$, $E(0) = 0.5$, and $T = 1$.

Name of program file: `fishery.py`.

◇

F.1 Using a Debugger

A debugger is a program that can help you to find out what is going on in a computer program. You can stop the execution at any prescribed line number, print out variables, continue execution, stop again, execute statements one by one, and repeat such actions until you track down abnormal behavior and find bugs.

Here we shall use the debugger to demonstrate the program flow of the `Simpson.py` code from Chapter 3.4.2. You are strongly encouraged to carry out the steps below on your computer to get a glimpse of what a debugger can do.

1. Go to the folder `src/funcif` associated with Chapter 3.
2. Start IPython:

```
Terminal
```

```
Terminal> ipython
```

3. Run the program `Simpson.py` with the debugger on (`-d`):

```
In [1]: run -d Simpson.py
```

We now enter the debugger and get a prompt

```
ipdb>
```

After this prompt we can issue various debugger commands. The most important ones will be described as we go along.

4. Type `continue` or just `c` to go to the first line in the file. Now you can see a printout of where we are in the program:

```

1---> 1 def Simpson(f, a, b, n=500):
      2     """
      3     Return the approximation of the integral of f

```

Each program line is numbered and the arrow points to the next line to be executed. This is called the *current line*.

5. You can set a *break point* where you want the program to stop so that you can examine variables and perhaps follow the execution closely. We start by setting a break point in the application function:

```

ipdb> break application
Breakpoint 2 at /home/.../src/funcif/Simpson.py:30

```

You can also say `break X`, where `X` is a line number in the file.

6. Continue execution until the break point by writing `continue` or `c`. Now the program stops at line 31 in the application function:

```

ipdb> c
> /home/.../src/funcif/Simpson.py(31)application()
2   30 def application():
---> 31     from math import sin, pi
      32     print 'Integral of 1.5*sin^3 from 0 to pi:'

```

7. Typing `step` or just `s` executes one statement at a time. Let us test this feature:

```

ipdb> s
> /home/.../src/funcif/Simpson.py(32)application()
      31     from math import sin, pi
---> 32     print 'Integral of 1.5*sin^3 from 0 to pi:'
      33     for n in 2, 6, 12, 100, 500:

ipdb> s
Integral of 1.5*sin^3 from 0 to pi:
> /home/.../src/funcif/Simpson.py(33)application()
      32     print 'Integral of 1.5*sin^3 from 0 to pi:'
---> 33     for n in 2, 6, 12, 100, 500:
      34         approx = Simpson(h, 0, pi, n)

```

Typing another `s` reaches the call to `Simpson`, and a new `s` steps *into* the function `Simpson`:

```

ipdb> s
--Call--
> /home/.../src/funcif/Simpson.py(1)Simpson()
1---> 1 def Simpson(f, a, b, n=500):
      2     """
      3     Return the approximation of the integral of f

```

Type a few more `s` to step ahead of the `if` tests.

8. Examining the contents of variables is easy with the `print` (or `p`) command:

```

ipdb> print f, a, b, n
<function h at 0x898ef44> 0 3.14159265359 2

```

We can also check the type of the objects:

```
ipdb> whatis f
Function h
ipdb> whatis a
<type'int'>
ipdb> whatis b
<type'float'>
ipdb> whatis n
<type'int'>
```

9. Set a new break point in the application function so that we can jump directly there without having to go manually through all the statements in the Simpson function. To see line numbers and corresponding statements around some line with number X, type list X. For example,

```
ipdb> list 32
27 def h(x):
28     return (3./2)*sin(x)**3
29
30 from math import sin, pi
31
2 32 def application():
33     print 'Integral of 1.5*sin^3 from 0 to pi:'
34     for n in 2, 6, 12, 100, 500:
35         approx = Simpson(h, 0, pi, n)
36         print 'n=%3d, approx=%18.15f, error=%9.2E' % \
37             (n, approx, 2-approx)
```

We set a line break at line 35:

```
ipdb> break 35
Breakpoint 3 at /home/.../src/funcif/Simpson.py:35
```

Typing c continues execution up to the next break point, line 35.

10. The command next or n is like step or s in that the current line is executed, but the execution does not step into functions, instead the function calls are just performed and the program stops at the next line:

```
ipdb> n
> /home/.../src/funcif/Simpson.py(36)application()
3 35     approx = Simpson(h, 0, pi, n)
---> 36     print 'n=%3d, approx=%18.15f, error=%9.2E' % \
      37         (n, approx, 2-approx)
ipdb> print approx, n
1.9891717005835792 6
```

11. The command disable X Y Z disables break points with numbers X, Y, and Z, and so on. To remove our three break points and continue execution until the program naturally stops, we write

```
ipdb> disable 1 2 3
ipdb> c
n=100, approx= 1.999999902476350, error= 9.75E-08
n=500, approx= 1.99999999844138, error= 1.56E-10

In [2]:
```

At this point, I hope you realize that a debugger is a very handy tool for monitoring the program flow, checking variables, and thereby understanding why errors occur.

F.2 How to Debug

Most programmers will claim that writing code consumes a small portion of the time it takes to develop a program – the major portion of the work concerns testing the program and finding errors¹. Newcomers to programming often panic when their program runs for the first time and aborts with a seemingly cryptic error message. How do you approach the art of debugging? This appendix summarizes some important working habits in this respect. Some of the tips are useful for problem solving in general, not only when writing and testing Python programs.

F.2.1 A Recipe for Program Writing and Debugging

1. Make sure that you *understand the problem* the program is supposed to solve. We can make a general claim: If you do not understand the problem and the solution method, you will never be able to make a correct program². It may be necessary to read a problem description or exercise many times and study relevant background material.
2. *Work out some examples* on input and output of the program. Such examples are important for controlling the understanding of the purpose of the program, and for verifying the implementation.
3. *Decide on a user interface*, i.e., how you want to get data into the program (command-line input, file input, questions and answers, etc.).
4. *Sketch rough algorithms* for various parts of the program. Some programmers prefer to do this on a piece of paper, others prefer to start directly in Python and write Python-like code with comments to sketch the program (this is easily developed into real Python code later).
5. *Look up information* on how to program different parts of the problem. Few programmers can write the whole program without con-

¹ “Debugging is twice as hard as writing the code in the first place. Therefore, if you write the code as cleverly as possible, you are, by definition, not smart enough to debug it.” –Brian W. Kernighan, computer scientist, 1942–.

² This is not entirely true. Sometimes students with limited understanding of the problem are able to grab a similar program and guess at a few modifications – and get a program that works. But this technique is based on luck and not on understanding. The famous Norwegian computer scientist Kristen Nygaard (1926–2002) phrased it precisely: “Programming is understanding”.

sulting manuals, books, and the Internet. You need to know and understand the basic constructs in a language and some fundamental problem solving techniques, but technical details can be looked up.

The more program examples you have studied (in this book, for instance), the easier it is to adapt ideas from an existing example to solve a new problem³. Remember that exercises in this book are often closely linked to examples in the text.

6. *Write the program.* Be extremely careful with what you write. In particular, compare all mathematical statements and algorithms with the original mathematical expressions on paper.

In longer programs, do not wait until the program is complete before you start testing it – test parts while you write.

7. *Run the program.* If the program aborts with an error message from Python, these messages are fortunately quite precise and helpful. First, locate the line number where the error occurs and read the statement, then carefully read the error message. The most common errors (exceptions) are listed below.

SyntaxError: Illegal Python code.

```
File "somefile.py", line 5
  x = : 5
      ^
SyntaxError: invalid syntax
```

Often the error is precisely indicated, as above, but sometimes you have to search for the error on the previous line.

NameError: A name (variable, function, module) is not defined.

```
File "somefile.py", line 20, in <module>
  table(10)
File "somefile.py", line 16, in table
  value, next, error = L(x, n)
File "somefile.py", line 8, in L
  exact_error = log(1+x) - value_of_sum
NameError: global name 'value_of_sum' is not defined
```

Look at the last of the lines starting with `File` to see where in the program the error occurs. The most common reasons for a `NameError` are

- a misspelled name,
- a variable that is not initialized,
- a function that you have forgotten to define,
- a module that is not imported.

TypeError: An object of wrong type is used in an operation.

```
File "somefile.py", line 17, in table
  value, next, error = L(x, n)
File "somefile.py", line 7, in L
```

³ “The secret to creativity is knowing how to hide your sources.” –Albert Einstein, physicist, 1879–1955.

```

    first_neglected_term = (1.0/(n+1))*(x/(1.0+x)**(n+1))
TypeError: unsupported operand type(s) for +: 'float' and 'str'

```

Print out objects and their types (here: `print x, type(x), n, type(n)`), and you will most likely get a surprise. The reason for a `TypeError` is often far away from the line where the `TypeError` occurs.

ValueError: An object has an illegal value.

```

    File "somefile.py", line 8, in L
    y = sqrt(x)
ValueError: math domain error

```

Print out the value of objects that can be involved in the error (here: `print x`).

IndexError: An index in a list, tuple, string, or array is too large.

```

    File "somefile.py", line 21
    n = sys.argv[i+1]
IndexError: list index out of range

```

Print out the length of the list, and the index if it involves a variable (here: `print len(sys.argv), i`).

8. *Verify the implementation.* Assume now that we have a program that runs without error messages from Python. Before judging the results of the program, set precisely up a test case where you know the exact solution⁴. Insert `print` statements for all key results in the program so that you can easily compare calculations in the program with those done by hand.

If your program produces wrong answers, start to *examine intermediate results*. Also remember that your hand calculations may be wrong!

9. If you need a lot of `print` statements in the program, you may *use a debugger* as explained in Appendix F.1.

Some may think that this list is very comprehensive. However, it just contains the items that you should always address when developing programs. Never forget that computer programming is a difficult task⁵!

F.2.2 Application of the Recipe

Let us illustrate the points above in a specific programming problem.

Problem. Implement the Midpoint rule for numerical integration. The Midpoint rule for approximating an integral $\int_a^b f(x)dx$ reads

⁴ This is in general quite difficult. In complicated mathematical problems it is an art to construct good test problems and procedures for providing evidence that the program works.

⁵ “Program writing is substantially more demanding than book writing.” “Why is it so? I think the main reason is that a larger attention span is needed when working on a large computer program than when doing other intellectual tasks.” –Donald Knuth [4, p. 18], computer scientist, 1938–.

$$I = h \sum_{i=1}^n f\left(a + \left(i - \frac{1}{2}\right)h\right), \quad h = \frac{b-a}{n}. \quad (\text{F.1})$$

Solution. We just follow the individual steps in the recipe.

1. *Understand the problem.* In this problem we must understand how to program the formula (F.1). Observe that we do not need to understand how the formula is derived, because we do not apply the derivation in the program⁶. What is important, is to notice that the formula is an *approximation* of an integral. If we try to integrate a function $f(x)$, we will probably not get an exact answer. Whether we have an approximation error or a programming error is always difficult to judge. We will meet this difficulty below.

2. *Work out examples.* As a test case we choose to integrate

$$f(x) = \sin^{-1}(x) \quad (\text{F.2})$$

between 0 and π . From a table of integrals we find that this integral equals

$$\left[x \sin^{-1}(x) + \sqrt{1-x^2}\right]_0^{\pi}. \quad (\text{F.3})$$

The formula (F.1) gives an approximation to this integral, so the program will (most likely) print out a result different from (F.3). It would therefore be very helpful to construct a calculation where there are no approximation errors. Numerical integration rules usually integrate some polynomial of low order exactly. For the Midpoint rule it is obvious, if you understand the derivation of this rule, that a constant function will be integrated exactly. We therefore also introduce a test problem where we integrate $g(x) = 1$ from 0 to 10. The answer should be exactly 10.

Input and output: The input to the calculations is the function to integrate, the integration limits a and b , and the n parameter (number of intervals) in the formula (F.1). The output from the calculations is the approximation to the integral.

3. *User interface.* We decide to program the two functions $f(x)$ and $g(x)$ directly in the program. We also specify the corresponding integration limits a and b in the program, but we read a common n for both integrals from the command line. Note that this is not a flexible user interface, but it suffices as a start for creating a working program. A much better user interface is to read f , a , b , and n from the command line, which will be done later in a more complete solution to the present problem.

4. *Algorithm.* Like most mathematical programming problems, also this one has a generic part and an application part. The generic part

⁶ You often need to understand the background for and the derivation of a mathematical formula in order to work out sensible test problems for verification. Sometimes this must be done by experts on the particular problem at hand.

is the formula (F.1), which is applicable to an arbitrary function $f(x)$. The implementation should reflect that we can specify any Python function $f(x)$ and get it integrated. This principle calls for calculating (F.1) in a Python function where the input to the computation (f , a , b , n) are arguments. The function heading can look as `integrate(f, a, b, n)`, and the value of (F.1) is returned.

The test part of the program consists of defining the test functions $f(x)$ and $g(x)$ and writing out the calculated approximations to the corresponding integrals.

A first rough sketch of the program can then be

```
def integrate(f, a, b, n):
    # compute integral, store in I
    return I

def f(x):
    ...

def g(x):
    ...

# test/application part:
n = sys.argv[1]
I = integrate(g, 0, 10, n)
print "Integral of g equals %g" % I
I = integrate(f, 0, pi, n)
# calculate and print out the exact integral of f
```

The next step is to make a detailed implementation of the `integrate` function. Inside this function we need to compute the sum (F.1). In general, sums are computed by a `for` loop over the summation index, and inside the loop we calculate a term in the sum and add it to an accumulation variable. Here is the algorithm:

<pre>s = 0 for i from 1 to n: s = s + f(a + (i - 1/2)h) I = sh</pre>
--

5. *Look up information.* Our test function $f(x) = \sin^{-1}(x)$ must be evaluated in the program. How can we do this? We know that many common mathematical functions are offered by the `math` module. It is therefore natural to check if this module has an inverse sine function. The best place to look for Python modules is the Python Library Reference (see Chapter 2.6.3). We go to the index of this manual, find the “math” entry, and click on it. Alternatively, you can write `pydoc math` on the command line. Browsing the manual for the `math` module shows that there is an inverse sine function, with the name `asin`.

In this simple problem, where we use very basic constructs from Chapters 1–4, there is hardly any need for looking at similar examples.

Nevertheless, if you are uncertain about programming a mathematical sum, you may look at examples from Chapters 2.1.4 and 3.1.4.

6. *Write the program.* Here is our first attempt to write the program. You can find the whole code in the file `appendix/integrate_v1.py`.

```
def integrate(f, a, b, n):
    s = 0
    for i in range(1, n):
        s += f(a + i*h)
    return s

def f(x):
    return asin(x)

def g(x):
    return 1

# Test/application part
n = sys.argv[1]
I = integrate(g, 0, 10, n)
print "Integral of g equals %g" % I
I = integrate(f, 0, pi, n)
I_exact = pi*asin(pi) - sqrt(1 - pi**2) - 1
print "Integral of f equals %g (exact value is %g)' % \
      (I, I_exact)
```

7. *Run the program.* We try a first execution from IPython

```
In [1]: run integrate_v1.py
```

Unfortunately, the program aborts with an error:

```
File "integrate_v1.py", line 8
    return asin(x)
           ^
```

`IndentationError: expected an indented block`

We go to line 8 and look at that line and the surrounding code:

```
def f(x):
    return asin(x)
```

Python expects that the return line is indented, because the function body must always be indented. By the way, we realize that there is a similar error in the `g(x)` function as well. We correct these errors:

```
def f(x):
    return asin(x)

def g(x):
    return 1
```

Running the program again makes Python respond with

```
File "integrate_v1.py", line 24
    (I, I_exact)^
SyntaxError: EOL while scanning single-quoted string
```

There is nothing wrong with line 24, but line 24 is a part of the statement starting on line 23:

```
print "Integral of f equals %g (exact value is %g)' % \
(I, I_exact)
```

A `SyntaxError` implies that we have written illegal Python code. Inspecting line 23 reveals that the string to be printed starts with a double quote, but ends with a single quote. We must be consistent and use the same enclosing quotes in a string. Correcting the statement,

```
print "Integral of f equals %g (exact value is %g)" % \
(I, I_exact)
```

and rerunning the program yields the output

```
Traceback (most recent call last):
  File "integrate_v1.py", line 18, in <module>
    n = sys.argv[1]
NameError: name 'sys' is not defined
```

Obviously, we need to import `sys` before using it. We add `import sys` and run again:

```
Traceback (most recent call last):
  File "integrate_v1.py", line 19, in <module>
    n = sys.argv[1]
IndexError: list index out of range
```

This is a very common error: We index the list `sys.argv` out of range because we have not provided enough command-line arguments. Let us use $n = 10$ in the test and provide that number on the command line:

```
In [5]: run integrate_v1.py 10
```

We still have problems:

```
Traceback (most recent call last):
  File "integrate_v1.py", line 20, in <module>
    I = integrate(g, 0, 10, n)
  File "integrate_v1.py", line 7, in integrate
    for i in range(1, n):
TypeError: range() integer end argument expected, got str.
```

It is the final File line that counts (the previous ones describe the nested functions calls up to the point where the error occurred). The error message for line 7 is very precise: The end argument to `range`, `n`, should be an integer, but it is a string. We need to convert the string `sys.argv[1]` to `int` before sending it to the `integrate` function:

```
n = int(sys.argv[1])
```

After a new edit-and-run cycle we have other error messages waiting:

```
Traceback (most recent call last):
  File "integrate_v1.py", line 20, in <module>
    I = integrate(g, 0, 10, n)
  File "integrate_v1.py", line 8, in integrate
    s += f(a + i*h)
NameError: global name 'h' is not defined
```

The `h` variable is used without being assigned a value. From the formula (F.1) we see that $h = (b - a)/n$, so we insert this assignment at the top of the `integrate` function:

```
def integrate(f, a, b, n):
    h = (b-a)/n
    ...
```

A new run results in a new error:

```
Integral of g equals 9
Traceback (most recent call last):
  File "integrate_v1.py", line 23, in <module>
    I = integrate(f, 0, pi, n)
NameError: name 'pi' is not defined
```

Looking carefully at all output, we see that the program managed to call the `integrate` function with `g` as input and write out the integral. However, in the call to `integrate` with `f` as argument, we get a `NameError`, saying that `pi` is undefined. When we wrote the program we took it for granted that `pi` was π , but we need to import `pi` from `math` to get this variable defined, before we call `integrate`:

```
from math import pi
I = integrate(f, 0, pi, n)
```

The output of a new run is now

```
Integral of g equals 9
Traceback (most recent call last):
  File "integrate_v1.py", line 24, in <module>
    I = integrate(f, 0, pi, n)
  File "integrate_v1.py", line 9, in integrate
    s += f(a + i*h)
  File "integrate_v1.py", line 13, in f
    return asin(x)
NameError: global name 'asin' is not defined
```

A similar error occurred: `asin` is not defined as a function, and we need to import it from `math`. We can either do a

```
from math import pi, asin
```

or just do the rough

```
from math import *
```

to avoid any further errors with undefined names from the `math` module (we will get one for the `sqrt` function later, so we simply use the last “import all” kind of statement).

There are still more errors:

```
Integral of g equals 9
Traceback (most recent call last):
  File "integrate_v1.py", line 24, in <module>
    I = integrate(f, 0, pi, n)
  File "integrate_v1.py", line 9, in integrate
    s += f(a + i*h)
  File "integrate_v1.py", line 13, in f
    return asin(x)
ValueError: math domain error
```

Now the error concerns a wrong x value in the f function. Let us print out x :

```
def f(x):
    print x
    return asin(x)
```

The output becomes

```
Integral of g equals 9
0.314159265359
0.628318530718
0.942477796077
1.25663706144
Traceback (most recent call last):
  File "integrate_v1.py", line 25, in <module>
    I = integrate(f, 0, pi, n)
  File "integrate_v1.py", line 9, in integrate
    s += f(a + i*h)
  File "integrate_v1.py", line 14, in f
    return asin(x)
ValueError: math domain error
```

We see that all the $\text{asin}(x)$ computations are successful up to and including $x = 0.942477796077$, but for $x = 1.25663706144$ we get an error. A “math domain error” may point to a wrong x value for $\sin^{-1}(x)$ (recall that the domain of a function specifies the legal x values for that function).

To proceed, we need to think about the mathematics of our problem: Since $\sin(x)$ is always between -1 and 1 , the inverse sine function cannot take x values outside the interval $[-1, 1]$. The problem is that we try to integrate $\sin^{-1}(x)$ from 0 to π , but only integration limits within $[-1, 1]$ make sense (unless we allow for complex-valued trigonometric functions). Our test problem is hence wrong from a mathematical point of view. We need to adjust the limits, say 0 to 1 instead of 0 to π . The corresponding program modification reads

```
I = integrate(f, 0, 1, n)
```

We run again and get

```
Integral of g equals 9
0
0
0
0
0
0
0
0
0
Traceback (most recent call last):
  File "integrate_v1.py", line 26, in <module>
    I_exact = pi*asin(pi) - sqrt(1 - pi**2) - 1
ValueError: math domain error
```

It is easy to go directly to the `ValueError` now, but one should always examine the output from top to bottom. If there is strange output before Python reports an error, there may be an error indicated by our `print` statements which causes Python to abort the program. This is not the case in the present example, but it is a good habit to start at

the top of the output anyway. We see that all our `print x` statements inside the `f` function say that `x` is zero. This must be wrong – the idea of the integration rule is to pick n different points in the integration interval $[0, 1]$.

Our `f(x)` function is called from the `integrate` function. The argument to `f`, `a + i*h`, is seemingly always 0. Why? We print out the argument and the values of the variables that make up the argument:

```
def integrate(f, a, b, n):
    h = (b-a)/n
    s = 0
    for i in range(1, n):
        print a, i, h, a+i*h
        s += f(a + i*h)
    return s
```

Running the program shows that `h` is zero and therefore `a+i*h` is zero.

Why is `h` zero? We need a new `print` statement in the computation of `h`:

```
def integrate(f, a, b, n):
    h = (b-a)/n
    print b, a, n, h
    ...
```

The output shows that `a`, `b`, and `n` are correct. Now we have encountered an error that we often discuss in this book: integer division (see Chapter 1.3.1). The formula $(1 - 0)/10 = 1/10$ is zero according to integer division. The reason is that `a` and `b` are specified as 0 and 1 in the call to `integrate`, and 0 and 1 imply `int` objects. Then `b-a` becomes an `int`, and `n` is an `int`, causing an `int/int` division. We must ensure that `b-a` is `float` to get the right mathematical division in the computation of `h`:

```
def integrate(f, a, b, n):
    h = float(b-a)/n
    ...
```

Thinking that the problem with wrong x values in the inverse sine function is resolved, we may remove all the `print` statements in the program, and run again.

The output now reads

```
Integral of g equals 9
Traceback (most recent call last):
  File "integrate_v1.py", line 25, in <module>
    I_exact = pi*asin(pi) - sqrt(1 - pi**2) - 1
ValueError: math domain error
```

That is, we are back to the `ValueError` we have seen before. The reason is that `asin(pi)` does not make sense, and the argument to `sqrt` is negative. The error is simply that we forgot to adjust the upper integration limit in the computation of the exact result. This is another very common error. The correct line is

```
I_exact = 1*asin(1) - sqrt(1 - 1**2) - 1
```

We could avoid the error by introducing variables for the integration limits, and a function for $\int f(x)dx$ would make the code cleaner:

```
a = 0; b = 1
def int_f_exact(x):
    return x*asin(x) - sqrt(1 - x**2)
I_exact = int_f_exact(b) - int_f_exact(a)
```

Although this is more work than what we initially aimed at, it usually saves time in the debugging phase to do things this proper way.

Eventually, the program seems to work! The output is just the result of our two print statements:

```
Integral of g equals 9
Integral of f equals 5.0073 (exact value is 0.570796)
```

8. *Verify the results.* Now it is time to check if the numerical results are correct. We start with the simple integral of 1 from 0 to 10: The answer should be 10, not 9. Recall that for this particular choice of integration function, there is no approximation error involved (but there could be a small round-off error). Hence, there must be a programming error.

To proceed, we need to calculate some intermediate mathematical results by hand and compare these with the corresponding statements in the program. We choose a very simple test problem with $n = 2$ and $h = (10 - 0)/2 = 5$. The formula (F.1) becomes

$$I = 5 \cdot (1 + 1) = 10.$$

Running the program with $n = 2$ gives

```
Integral of g equals 1
```

We insert some print statements inside the `integrate` function:

```
def integrate(f, a, b, n):
    h = float(b-a)/n
    s = 0
    for i in range(1, n):
        print 'i=%d, a+i*h=%g' % (i, a+i*h)
        s += f(a + i*h)
    return s
```

Here is the output:

```
i=1, a+i*h=5
Integral of g equals 1
i=1, a+i*h=0.5
Integral of f equals 0.523599 (exact value is 0.570796)
```

There was only one pass in the `i` loop in `integrate`. According to the formula, there should be n passes, i.e., two in this test case. The limits of `i` must be wrong. The limits are produced by the call `range(1,n)`. We recall that such a call results in integers going from 1 up to `n`, but

not including n . We need to include n as value of i , so the right call to `range` is `range(1,n+1)`.

We make this correction and rerun the program. The output is now

```
i=1, a+i*h=5
i=2, a+i*h=10
Integral of g equals 2
i=1, a+i*h=0.5
i=2, a+i*h=1
Integral of f equals 2.0944 (exact value is 0.570796)
```

The integral of 1 is still not correct. We need more intermediate results!

In our quick hand calculation we knew that $g(x) = 1$ so all the $f(a + (i - \frac{1}{2})h)$ evaluations were rapidly replaced by ones. Let us now compute all the x coordinates $a + (i - \frac{1}{2})h$ that are used in the formula:

$$i = 1 : a + \left(i - \frac{1}{2}\right)h = 2.5, \quad i = 2 : a + \left(i - \frac{1}{2}\right)h = 7.5.$$

Looking at the output from the program, we see that the argument to `g` has a different value – and fortunately we realize that the formula we have coded is wrong. It should be `a+(i-0.5)*h`.

We correct this error and run the program:

```
i=1, a+(i-0.5)*h=2.5
i=2, a+(i-0.5)*h=7.5
Integral of g equals 2
...
```

Still the integral is wrong⁷.

Now we read the code more carefully and compare expressions with those in the mathematical formula. We should, of course, have done this already when writing the program, but it is easy to get excited when writing code and hurry for the end. This ongoing story of debugging probably shows that reading the code carefully can save much debugging time⁸. We clearly add up all the f evaluations correctly, but then this sum must be multiplied by h , and we forgot that in the code. The `return` statement in `integrate` must therefore be modified to

```
return s*h
```

Eventually, the output is

```
Integral of g equals 10
Integral of f equals 0.568484 (exact value is 0.570796)
```

and we have managed to integrate a constant function in our program! Even the second integral looks promising!

To judge the result of integrating the inverse sine function, we need to run several increasing n values and see that the approximation gets

⁷ At this point you may give up programming, but the more skills you pick up in debugging, the more fun it is to hunt for errors! Debugging is like reading an exciting criminal novel: the detective follows different ideas and tracks, but never gives up before the culprit is caught.

⁸ Actually, being extremely careful with what you write, and comparing all formulas with the mathematics, may be the best way to get more spare time when taking a programming course!

better. For $n = 2, 10, 100, 1000$ we get 0.550371, 0.568484, 0.570714, 0.570794, to be compared to the exact⁹ value 0.570796. The decreasing error provides evidence for a correct program, but it is not a strong proof. We should try out more functions. In particular, linear functions are integrated exactly by the Midpoint rule. We can also measure the speed of the decrease of the error and check that the speed is consistent with the properties of the Midpoint rule, but this is a mathematically more advanced topic.

The very important lesson learned from these debugging sessions is that you should start with a simple test problem where all formulas can be computed by hand. If you start out with $n = 100$ and try to integrate the inverse sine function, you will have a much harder job with tracking down all the errors.

9. *Use a debugger.* Another lesson learned from these sessions is that we needed many `print` statements to see intermediate results. It is an open question if it would be more efficient to run a debugger and stop the code at relevant lines. In an edit-and-run cycle of the type we met here, we frequently need to examine many numerical results, correct something, and look at all the intermediate results again. Plain `print` statements are often better suited for this massive output than the pure manual operation of a debugger, unless one writes a program to automate the interaction with the debugger.

The correct code for the implementation of the Midpoint rule is found in `integrate_v2.py`. Some readers might be frightened by all the energy it took to debug this code, but this is just the nature of programming. The experience of developing programs that finally work is very awarding¹⁰.

Refining the User Interface. We briefly mentioned that the chosen user interface, where the user can only specify n , is not particularly user friendly. We should allow f , a , b , and n to be specified on the command line. Since f is a function and the command line can only provide strings to the program, we may use the `StringFunction` object from `scitools.std` to convert a string expression for the function to be integrated to an ordinary Python function (see Chapter 4.1.4). The other parameters should be easy to retrieve from the command line if Chapter 4.2 is understood. As suggested in Chapter 4.3, we enclose the input statements in a `try-except` block, here with a specific exception type `IndexError` (because an index in `sys.argv` out of bounds is the only type of error we expect to handle):

⁹ This is not the mathematically exact value, because it involves computations of $\sin^{-1}(x)$, which is only approximately calculated by the `asin` function in the `math` module. However, the approximation error is very small ($\sim 10^{-16}$).

¹⁰ “People only become computer programmers if they’re obsessive about details, crave power over machines, and can bear to be told day after day exactly how stupid they are.” –Gregory J.E. Rawlins, computer scientist. Quote from the book “Slaves of the Machine: The Quickening of Computer Technology”, MIT Press, 1997.

```

try:
    f_formula = sys.argv[1]
    a = eval(sys.argv[2])
    b = eval(sys.argv[3])
    n = int(sys.argv[4])
except IndexError:
    print 'Usage: %s f-formula a b n' % sys.argv[0]
    sys.exit(1)

```

Note that the use of `eval` allows us to specify `a` and `b` as `pi` or `exp(5)` or another mathematical expression.

With the input above we can perform the general task of the program:

```

from scitools.std import StringFunction
f = StringFunction(f_formula)
I = integrate(f, a, b, n)
print I

```

Instead of having these test statements as a main program we follow the good habits of Chapter 4.5 and make a module with (i) the `integrate` function, (ii) a `verify` function for testing the `integrate` function's ability to exactly integrate linear functions, and (iii) a main function for reading data from the command line and calling `integrate` for the user's problem at hand. Any module should also have a test block, and doc strings for the module itself and all functions.

The `verify` function performs a loop over some specified `n` values and checks that the Midpoint rule integrates a linear function exactly¹¹. In the test block we can either run the `verify` function or the main function.

The final solution to the problem of implementing the Midpoint rule for numerical integration is now the following complete module file `integrate.py`:

```

"""Module for integrating functions by the Midpoint rule."""
from math import *
import sys

def integrate(f, a, b, n):
    """Return the integral of f from a to b with n intervals."""
    h = float(b-a)/n
    s = 0
    for i in range(1, n+1):
        s += f(a + (i-0.5)*h)
    return s*h

def verify():
    """Check that linear functions are integrated exactly."""

    def g(x):
        return p*x + q # general linear function

    def int_g_exact(x): # integral of g(x)
        return 0.5*p*x**2 + q*x

```

¹¹ We must be prepared for round-off errors, so “exactly” means errors less than (say) 10^{-14} .

```

a = -1.2; b = 2.8    # "arbitrary" integration limits
p = -2;  q = 10
passed = True      # True if all tests below are passed
for n in 1, 10, 100:
    I = integrate(g, a, b, n)
    I_exact = int_g_exact(b) - int_g_exact(a)
    error = abs(I_exact - I)
    if error > 1E-14:
        print 'Error=%g for n=%d' % (error, n)
        passed = False
if passed: print 'All tests are passed.'

def main():
    """
    Read f-formula, a, b, n from the command line.
    Print the result of integrate(f, a, b, n).
    """
    try:
        f_formula = sys.argv[1]
        a = eval(sys.argv[2])
        b = eval(sys.argv[3])
        n = int(sys.argv[4])
    except IndexError:
        print 'Usage: %s f-formula a b n' % sys.argv[0]
        sys.exit(1)

    from scitools.std import StringFunction
    f = StringFunction(f_formula)
    I = integrate(f, a, b, n)
    print I

if __name__ == '__main__':
    if sys.argv[1] == 'verify':
        verify()
    else:
        # Compute the integral specified on the command line
        main()

```

Here is a short demo computing $\int_0^{2\pi} (\cos(x) + \sin(x))dx$:

```

Terminal
integrate.py'cos(x)+sin(x)' 0 2*pi 10
-3.48786849801e-16

```

Python is a very convenient language for implementing scientific computations as the code can be made very close to the mathematical algorithms. However, the execution speed of the code is significantly lower than what can be obtained by programming in languages such as Fortran, C, or C++. These languages *compile* the program to machine language, which enables the computing resources to be utilized with very high efficiency. Frequently, and this includes almost all examples in the present book, Python is fast enough. But in the cases where speed really matters, can we increase the efficiency without rewriting the whole program in Fortran, C, or C++? The answer is yes, which will be illustrated through a case study in the forthcoming text.

Fortunately, Python was initially designed for being integrated with C. This feature has spawned the development of several techniques and tools for calling compiled languages from Python, allowing us to relatively easily reuse fast and well-tested scientific libraries in Fortran, C, or C++ from Python, *or* migrate slow Python code to compiled languages. It often turns out that only smaller parts of the code, usually `for` loops doing heavy numerical computations, suffer from low speed and can benefit from being implemented in Fortran, C, or C++.

The primary technique to be advocated here is to use Cython. Cython can be viewed as an extension of the Python language where variables can be declared with a type and other information such that Cython is able to automatically generate special-purpose, fast C code from the Python code. We will show how to utilize Cython and what the computational gain might be.

The present case study starts with stating a computational problem involving statistical simulations, which are known to cause long execution times, especially if accurate results are desired.

G.1 Pure Python Code for Monte Carlo Simulation

A short, intuitive algorithm in Python is first developed. Then this code is vectorized using functionality of the Numerical Python package. Later sections migrate the algorithm to Cython code and also plain C code for comparison. At the end the various techniques are ranked according to their computational efficiency.

G.1.1 The Computational Problem

A die is thrown m times. What is the probability of getting six eyes *at least* n times? For example, if $m = 5$ and $n = 3$, this is the same as asking for the probability that three or more out of five dice show six eyes.

The probability can be estimated by Monte Carlo simulation. Chapter 8.3 provides a background for this technique: We simulate the process a large number of times, N , and count how many times, M , the experiment turned out successfully, i.e., when we got at least n out of m dice with six eyes in a throw.

Monte Carlo simulation has traditionally been viewed as a very costly computational method, normally requiring very sophisticated, fast computer implementations in compiled languages. An interesting question is how useful high-level languages like Python and associated tools are for Monte Carlo simulation. This will now be explored.

G.1.2 A Scalar Python Implementation

Let us introduce the more descriptive variables `ndice` for m and `nsix` for n . The Monte Carlo method is simply a loop, repeated N times, where the body of the loop may directly express the problem at hand. Here, we draw `ndice` random integers r in $[1, 6]$ inside the loop and count of many (`six`) that equal 6. If `six` \geq `nsix`, the experiment is a success and we increase the counter M by one.

A Python function implementing this approach may look as follows:

```
import random

def dice6_py(N, ndice, nsix):
    M = 0                # no of successful events
    for i in range(N):   # repeat N experiments
        six = 0         # how many dice with six eyes?
        for j in range(ndice):
            r = random.randint(1, 6) # roll die no. j
            if r == 6:
                six += 1
        if six >= nsix:   # successful event?
            M += 1
    p = float(M)/N
    return p
```

The `float(M)` transformation is important since M/N will imply integer division when M and N both are integers in Python v2.x and many other languages.

We will refer to this implementation as the *plain Python* implementation. Timing the function can be done by:

```
import time
t0 = time.clock()
p = dice6_py(N, ndice, nsix)
t1 = time.clock()
print 'CPU time for loops in Python:', t1-t0
```

The table to appear later shows the performance of this plain, pure Python code relative to other approaches. There is a factor of 30+ to be gained in computational efficiency by reading on.

The function above can be verified by studying the (somewhat simplified) case $m = n$ where the probability becomes 6^{-n} . The probability quickly becomes small with increasing n . For such small probabilities the number of successful events M is small, and M/N will not be a good approximation to the probability unless M is reasonably large, which requires a very large N . For example, with $n = 4$ and $N = 10^5$ the average probability in 25 full Monte Carlo experiments is 0.00078 while the exact answer is 0.00077. With $N = 10^6$ we get the two correct significant digits from the Monte Carlo simulation, but the extra digit costs a factor of 10 in computing resources since the CPU time scales linearly with N .

G.1.3 A Vectorized Python Implementation

A vectorized version of the previous program consists of replacing the explicit loops in Python by efficient operations on vectors or arrays, using functionality in the Numerical Python (`numpy`) package. Each array operation takes place in C or Fortran and is hence much more efficient than the corresponding loop version in Python.

First, we must generate all the random numbers to be used in one operation, which runs fast since all numbers are then calculated in efficient C code. This is accomplished using the `numpy.random` module. Second, the analysis of the large collection of random numbers must be done by appropriate vector/array operations such that no looping in Python is needed. The solution algorithm must therefore be expressed through a series of function calls to the `numpy` library. Vectorization requires knowledge of the library's functionality and how to assemble the relevant building blocks to an algorithm without operations on individual array elements.

Generation of `ndice` random number of eyes for N experiments is performed by

```
import numpy as np
eyes = np.random.random_integers(1, 6, size=(N, ndice))
```

Each row in the `eyes` array corresponds to one Monte Carlo experiment.

The next step is to count the number of successes in each experiment. This counting should not make use of any loop. Instead we can test `eyes == 6` to get a boolean array where an element `i, j` is `True` if throw (or die) number `j` in Monte Carlo experiment number `i` gave six eyes. Summing up the rows in this boolean array (`True` is interpreted as 1 and `False` as 0), we are interested in the rows where the sum is equal to or greater than `nsix`, because the number of such rows equals the number of successful events. The vectorized algorithm can be expressed as

```
def dice6_vec1(N, ndice, nsix):
    eyes = np.random.random_integers(1, 6, size=(N, ndice))
    compare = eyes == 6
    throws_with_6 = np.sum(compare, axis=1) # sum over columns
    nsuccesses = throws_with_6 >= nsix
    M = np.sum(nsuccesses)
    p = float(M)/N
    return p
```

The use of `np.sum` instead of Python's own `sum` function is essential for the speed of this function: using `M = sum(nsuccesses)` instead slows down the code by a factor of almost 10! We shall refer to the `dice6_vec1` function as the *vectorized Python, version 1* implementation.

The criticism against the vectorized version is that the original problem description, which was almost literally turned into Python code in the `dice6_py` function, has now become much more complicated. We have to decode the calls to various `numpy` functionality to actually realize that `dice6_py` and `dice6_vec` correspond to the same mathematics.

Here is another possible vectorized algorithm, which is easier to understand, because we retain the Monte Carlo loop and vectorize only each individual experiment:

```
def dice6_vec2(N, ndice, nsix):
    eyes = np.random.random_integers(1, 6, (N, ndice))
    six = [6 for i in range(ndice)]
    M = 0
    for i in range(N):
        # Check experiment no. i:
        compare = eyes[i,:] == six
        if np.sum(compare) >= nsix:
            M += 1
    p = float(M)/N
    return p
```

We refer to this implementation as *vectorized Python, version 2*. As will be shown later, this implementation is significantly slower than the *plain Python* implementation (!) and very much slower than the *vectorized Python, version 1* approach. A conclusion is that readable,

partially vectorized code, may run slower than straightforward scalar code.

G.2 Migrating Scalar Python Code to Cython

G.2.1 A Plain Cython Implementation

A Cython program starts with the scalar Python implementation, but all variables are specified with their types, using Cython's variable declaration syntax, like `cdef int M = 0` where we in standard Python just write `M = 0`. Adding such variable declarations in the scalar Python implementation is straightforward:

```
import random

def dice6_cy1(int N, int ndice, int nsix):
    cdef int M = 0          # no of successful events
    cdef int six, r
    cdef double p
    for i in range(N):     # repeat N experiments
        six = 0            # how many dice with six eyes?
        for j in range(ndice):
            r = random.randint(1, 6) # roll die no. j
            if r == 6:
                six += 1
            if six >= nsix:        # successful event?
                M += 1
    p = float(M)/N
    return p
```

This code must be put in a separate file with extension `.pyx`. Running Cython on this file translates the Cython code to C. Thereafter, the C code must be compiled and linked to form a shared library, which can be imported in Python as a module. All these tasks are normally automated by a `setup.py` script. Let the `dice6_cy1` function above be stored in a file `dice6.pyx`. A proper `setup.py` script looks as follows:

```
from distutils.core import setup
from distutils.extension import Extension
from Cython.Distutils import build_ext

setup(
    name='Monte Carlo simulation',
    ext_modules=[Extension('_dice6_cy', ['dice6.pyx'],)],
    cmdclass={'build_ext': build_ext},
)
```

Running

Terminal

```
Terminal> python setup.py build_ext --inplace
```

generates the C code and creates a (shared library) file `_dice6_cy.so` (known as a *C extension module*) which can be loaded into Python as a module with name `_dice6_cy`:

```

from_dice6_cy import dice6_cy1
import time
t0 = time.clock()
p = dice6_cy1(N, ndice, nsix)
t1 = time.clock()
print t1 - t0

```

We refer to this implementation as *Cython random.randint*. Although most of the statements in the `dice6_cy1` function are turned into plain and fast C code, the speed is not much improved compared with the original scalar Python code.

To investigate what takes time in this Cython implementation, we can perform a profiling. The template for profiling a Python function whose call syntax is stored in some string `statement`, reads

```

import cProfile, pstats
cProfile.runctx(statement, globals(), locals(), '.prof')
s = pstats.Stats('.prof')
s.strip_dirs().sort_stats('time').print_stats(30)

```

Here, we set

```
statement = 'dice6_cy1(N, ndice, nsix)'
```

In addition, a Cython file in which there are functions we want to profile must start with the line

```
# cython: profile=True
```

to turn on profiling when creating the extension module. The profiling output from the present example looks like

```
5400004 function calls in 7.525 CPU seconds
```

```
Ordered by: internal time
```

ncalls	tottime	percall	cumtime	percall	filename:lineno(function)
1800000	4.511	0.000	4.863	0.000	random.py:160(randrange)
1800000	1.525	0.000	6.388	0.000	random.py:224(randint)
1	1.137	1.137	7.525	7.525	dice6.pyx:6(dice6_cy1)
1800000	0.352	0.000	0.352	0.000	{method 'random' ...}
1	0.000	0.000	7.525	7.525	{dice6_cy.dice6_cy1}

We easily see that it is the call to `random.randint` that consumes almost all the time. The reason is that the generated C code must call a Python module (`random`), which implies a lot of overhead. The C code should only call plain C functions, or if Python functions *must* be called, they should involve so much computations that the overhead in calling Python from C is negligible.

Instead of profiling the code to uncover inefficient constructs we can generate a visual representation of how the Python code is translated to C. Running

```
Terminal> cython -a dice6.pyx
```

creates a file `dice6.html` which can be loaded into a web browser to inspect what Cython has done with the Python code.

Raw output: [roll_dice.c](#)

```

1: import numpy as np
2: cimport numpy as np
3: import random
4:
5: def roll_dice1(int N, int ndice, int nsix):
6:     cdef int M = 0          # no of successful events
7:     cdef int six, r
8:     cdef double p
9:     for i in range(N):
10:         six = 0           # how many dice with six eyes?
11:         for j in range(ndice):
12:             # Roll die no. j
13:             r = random.randint(1, 6)
14:             if r == 6:
15:                 six += 1
16:             if six >= nsix: # Successful event?
17:                 M += 1
18:         p = float(M)/N
19:     return p

```

White lines indicate that the Python code is translated into C code, while the yellow lines indicate that the generated C code must make calls back to Python (using the Python C API, which implies overhead). Here, the `random.randint` call is in yellow, so this call is not translated to efficient C code.

G.2.2 A Better Cython Implementation

To speed up the previous Cython code, we have to get rid of the `random.randint` call every time we need a random variable. Either we must call some C function for generating a random variable or we must create a bunch of random numbers simultaneously as we did in the vectorized functions shown above. We first try the latter well-known strategy and apply the `numpy.random` module to generate all the random numbers we need at once:

```

import numpy as np
cimport numpy as np

cdef np.ndarray[np.int_t,
                ndim=2,
                negative_indices=False,
                mode='c'] eyes = \
    np.random.random_integers(1, 6, (N, ndice))

```

This code needs some explanation. The `cimport` statement imports a special version of `numpy` for Cython and is needed *after* the standard `numpy` import. The declaration of the array of random numbers could just go as

```
cdef np.ndarray eyes = np.random.random_integers(1, 6, (N, ndice))
```

However, the processing of the `eyes` array will then be slow because Cython does not have enough information about the array. To generate optimal C code, we must provide information on the element types in the array, the number of dimensions of the array, that the array is stored in contiguous memory, and that we do not need negative indices (which slows down array indexing). All this information is inserted in square brackets: `np.int_t` denotes integer array elements (`np.int` is the usual data type object, but `np.int_t` is a Cython precompiled version of this object), `ndim=2` tells that the array has two dimensions (indices), `negative_indices=False` turns off the possibility for negative indices (counting from the end), and `mode='c'` indicates contiguous storage of the array. We also insert a line `@cython.boundscheck(False)` at the line before the function to tell Cython to turn off the costly check that array indices stay within their bounds. With all this extra information, Cython can generate C code that works with numpy arrays as efficiently as native C arrays.

The rest of the code is a plain copy of the `dice6_py` function, but with the `random.randint` call replaced by an array look-up `eyes[i,j]` to retrieve the next random number. The two loops will now be as efficient as if they were coded directly in pure C.

The complete code for the efficient version of the `dice6_cy1` function looks as follows:

```
import numpy as np
cimport numpy as np
import cython
@cython.boundscheck(False)
def dice6_cy2(int N, int ndice, int nsix):
    # Use numpy to generate all random numbers
    cdef int M = 0          # no of successful events
    cdef int six, r
    cdef double p
    cdef np.ndarray[np.int_t,
                    ndim=2,
                    negative_indices=False,
                    mode='c'] eyes = \
        np.random.random_integers(1, 6, (N, ndice))
    for i in range(N):
        six = 0          # how many dice with six eyes?
        for j in range(ndice):
            r = eyes[i,j] # roll die no. j
            if r == 6:
                six += 1
        if six >= nsix:  # successful event?
            M += 1
    p = float(M)/N
    return p
```

This Cython implementation is named *Cython numpy.random*.

The disadvantage with the `dice6_cy2` function is that large simulations (large `N`) also require large amounts of memory, which usually limits the possibility for high accuracy much more than the CPU time.

It would be advantageous to have a fast random number generator like `rand()` in C. The C library `stdlib` has a generator of random integers, `rand()`, generating numbers from 0 to up `RAND_MAX`. Both the `rand` function and the `RAND_MAX` integer are easy to access in a Cython program:

```
from libc.stdlib cimport rand, RAND_MAX
r = 1 + int(rand()/(RAND_MAX*6.0)) # random integer 1,...,6
```

Note that `rand()` returns an integer so we must avoid integer division by ensuring that the denominator is a real number. We also need to explicitly convert the resulting real fraction to `int` since `r` is declared as `int`.

With this way of generating random numbers we can create a version of `dice6_cy1` that is as fast as `dice6_cy`, but avoids all the memory demands and the somewhat complicated array declarations of the latter:

```
from libc.stdlib cimport rand, RAND_MAX
def dice6_cy3(int N, int ndice, int nsix):
    cdef int M = 0 # no of successful events
    cdef int six, r
    cdef double p
    for i in range(N):
        six = 0 # how many dice with six eyes?
        for j in range(ndice):
            # Roll die no. j
            r = 1 + int(rand()/(RAND_MAX*6.0))
            if r == 6:
                six += 1
        if six >= nsix: # successful event?
            M += 1
    p = float(M)/N
    return p
```

This final Cython implementation will be referred to as *Cython `stdlib.rand`*.

G.3 Migrating Code to C

G.3.1 Writing a C Program

A natural next improvement would be to program the Monte Carlo simulation loops directly in a compiled programming language, which guarantees optimal speed. Here we choose the C programming language for this purpose. The C version of our `dice6` function and an associated main program take the form

```
#include <stdio.h>
#include <stdlib.h>

double dice6(int N, int ndice, int nsix)
```

```

{
  int M = 0;
  int six, r, i, j;
  double p;

  for (i = 0; i < N; i++) {
    six = 0;
    for (j = 0; j < ndice; j++) {
      r = 1 + rand()/(RAND_MAX*6.0); /* roll die no. j */
      if (r == 6)
        six += 1;
    }
    if (six >= nsix)
      M += 1;
  }
  p = ((double) M)/N;
  return p;
}

int main(int nargs, const char* argv[])
{
  int N = atoi(argv[1]);
  int ndice = 6;
  int nsix = 3;
  double p = dice6(N, ndice, nsix);
  printf("C code: N=%d, p=%.6f\n", N, p);
  return 0;
}

```

This code is placed in a file `dice6_c.c`. The file can typically be compiled and run by

```

Terminal
Terminal> gcc -O3 -o dice6.capp dice6_c.c
Terminal> ./dice6.capp 1000000

```

This solution is later referred to as *C program*.

G.3.2 Migrating Loops to C Code via F2PY

Instead of programming the whole application in C, we may consider migrating the loops to the C function `dice6` shown above and then have the rest of the program (essentially the calling main program) in Python. This is a convenient solution if we were to do many other, less CPU-time critical things for convenience in Python.

There are many alternative techniques for calling C functions from Python. Here we shall explain two. The first applies the program `f2py` to generate the necessary code that glues Python and C. The `f2py` program was actually made for gluing Python and Fortran, but it can work with C too. We need a specification of the C function to call in terms of a Fortran 90 module. Such a module can be written by hand, but `f2py` can also generate it. To this end, we make a Fortran file `dice6_c_signature.f` with the signature of the C function written in Fortran 77 syntax with some annotations:

```

real*8 function dice6(n, ndice, nsix)
Cf2py intent(c) dice6
    integer n, ndice, nsix
Cf2py intent(c) n, ndice, nsix
    return
end

```

The annotations `intent(c)` are necessary to tell `f2py` that the Fortran variables are to be treated as plain C variables and not as pointers (which is the default interpretation of variables in Fortran). The `Cf2py` are special comment lines that `f2py` recognizes, and these lines are used to provide extra information to `f2py` which have no meaning in plain Fortran 77.

We must run `f2py` to generate a `.pyf` file with a Fortran 90 module specification of the C function to call:

```

Terminal
Terminal> f2py -m_dice6_c1 -h dice6_c.pyf \
           dice6_c_signature.f

```

Here `_dice6_c1` is the name of the module with the C function that is to be imported in Python, and `dice6_c.pyf` is the name of the Fortran 90 module file to be generated. Programmers who know Fortran 90 may want to write the `dice6_c.pyf` file by hand.

The next step is to use the information in `dice6_c.pyf` to generate a (C extension) module `_dice6_c1`. Fortunately, `f2py` generates the necessary code, and compiles and links the relevant files, to form a shared library file `_dice6_c1.so`, by a short command:

```

Terminal
Terminal> f2py -c dice6_c.pyf dice6_c.c

```

We can now test the module:

```

>>> import _dice6_c1
>>> print dir(_dice6_c1) # module contents
['__doc__', '__file__', '__name__', '__package__',
 '__version__', 'dice6']
>>> print _dice6_c1.dice6.__doc__
dice6 - Function signature:
    dice6 = dice6(n,ndice,nsix)
Required arguments:
    n : input int
    ndice : input int
    nsix : input int
Return objects:
    dice6 : float
>>> _dice6_c1.dice6(N=1000, ndice=4, nsix=2)
0.145

```

The method of calling the C function `dice6` via an `f2py` generated module is referred to as *C via f2py*.

G.3.3 Migrating Loops to C Code via Cython

The Cython tool can also be used to call C code, not only generating C code from the Cython language. Our C code is in the file `dice6_c.c`, but for Cython to see this code we need to create a *header file* `dice6_c.h` listing the definition of the function(s) we want to call from Python. The header file takes the form

```
#include <stdio.h>
#include <stdlib.h>

extern double dice6(int N, int ndice, int nsix);
```

The next step is to make a `.pyx` file with a definition of the C function from the header file and a Python function that calls the C function:

```
cdef extern from "dice6_c.h":
    double dice6(int N, int ndice, int nsix)

def dice6_cwrap(int N, int ndice, int nsix):
    return dice6(N, ndice, nsix)
```

Cython must use this file, named `dice6_cwrap.pyx`, to generate C code, which is to be compiled and linked with the `dice6_c.c` code. All this is accomplished in a `setup.py` script:

```
from distutils.core import setup
from distutils.extension import Extension
from Cython.Distutils import build_ext

sources = ['dice6_cwrap.pyx', 'dice6_c.c']

setup(
    name='Monte Carlo simulation',
    ext_modules=[Extension('_dice6_c2', sources)],
    cmdclass={'build_ext': build_ext},
)
```

This `setup.py` script is run as

```
Terminal
Terminal> python setup.py build_ext --inplace
```

resulting in a shared library file `_dice6_c2.so`, which can be loaded into Python as a module:

```
>>> import _dice6_c2
>>> print dir(_dice6_c2)
['__builtins__', '__doc__', '__file__', '__name__',
 '__package__', '__test__', 'dice6_cwrap']
```

We see that the module contains the function `dice6_cwrap`, which was made to call the underlying C function `dice6`.

G.3.4 Comparing Efficiency

All the files corresponding to the various techniques described above are available in the directory `src/cython`. A file `make.sh` performs all the compilations, while `compare.py` runs all methods and prints out the CPU time required by each method, normalized by the fastest approach. The results for $N = 450,000$ are listed below (MacBook Air running Ubuntu in a VMWare Fusion virtual machine).

Method	Timing
C program	1.0
Cython <code>stdlib.rand</code>	1.2
Cython <code>numpy.random</code>	1.2
C via <code>f2py</code>	1.2
C via Cython	1.2
vectorized Python, version 1	1.9
Cython <code>random.randint</code>	33.6
plain Python	37.7
vectorized Python, version 2	105.0

The CPU time of the plain Python version was 10 s, which is reasonably fast for obtaining a fairly accurate result in this problem. The lesson learned is therefore that a Monte Carlo simulation can be implemented in plain Python first. If more speed is needed, one can just add type information and create a Cython code. Studying the HTML file with what Cython manages to translate to C may give hints about how successful the Cython code is and point to optimizations, like avoiding the call to `random.randint` in the present case. Optimal Cython code runs here at approximately the same speed as calling a handwritten C function with the time-consuming loops. It is to be noticed that the stand-alone C program here ran faster than calling C from Python, probably because the amount of calculations is not large enough to make the overhead of calling C negligible.

Vectorized Python do give a great speed-up compared to plain loops in Python, if done correctly, but the efficiency is not on par with Cython or handwritten C. Even more important is the fact that vectorized code is not at all as readable as the algorithm expressed in plain Python, Cython, or C. Cython therefore provides a very attractive combination of readability, ease of programming, and high speed.

H.1 Different Ways of Running Python Programs

Python programs are compiled and interpreted by another program called `python`. To run a Python program, you need to tell the operating system that your program is to be interpreted by the `python` program. This section explains various ways of doing this.

H.1.1 Executing Python Programs in IPython

The simplest and most flexible way of executing a Python program is to run it inside IPython. See Chapter 1.5.3 for a quick introduction to IPython. You start IPython either by the command `ipython` in a terminal window, or by double-clicking the IPython program icon (on Windows). Then, inside IPython, you can run a program `prog.py` by

```
In [1]: run prog.py arg1 arg2
```

where `arg1` and `arg2` are command-line arguments.

This method of running Python programs works the same way on all platforms. One additional advantage of running programs under IPython is that you can automatically enter the Python debugger if an exception is raised (see Appendix F.1). Although we advocate running Python programs under IPython in this book, you can also run them directly under specific operating systems. This is explained next for Unix, Windows, and Mac OS X.

H.1.2 Executing Python Programs on Unix

There are two ways of executing a Python program `prog.py` on Unix. The first explicitly tells which Python interpreter to use:

```
Terminal
Unix> python prog.py arg1 arg2
```

Here, `arg1` and `arg2` are command-line arguments.

There may be many Python interpreters on your computer system, usually corresponding to different versions of Python or different sets of additional packages and modules. The Python interpreter (`python`) used in the command above is the first program with the name `python` appearing in the folders listed in your `PATH` environment variable. A specific `python` interpreter, say in `/home/hpl/local/bin`, can easily be used to run a program `prog.py` in the current working folder by specifying the interpreter's complete filepath:

```
Terminal
Unix> /home/hpl/bin/python prog.py arg1 arg2
```

The other way of executing Python programs on Unix consists of just writing the name of the file:

```
Terminal
Unix> ./prog.py arg1 arg2
```

The leading `./` is needed to tell that the program is located in the current folder. You can also just write

```
Terminal
Unix> prog.py arg1 arg2
```

but then you need to have the dot¹ in the `PATH` variable, and this is not recommended for security reasons.

In the two latter commands there is no information on which Python interpreter to use. This information must be provided in the first line of the program, normally as

```
#!/usr/bin/env python
```

This looks like a comment line, and behaves indeed as a comment line when we run the program as `python prog.py`. However, when we run the program as `./prog.py`, the first line beginning with `#!` tells the operating system to use the program specified in the rest of the first line to interpret the program. In this example, we use the first `python` program encountered in the folders in your `PATH` variable. Alternatively, a specific `python` program can be specified as

¹ The dot acts as the name of the current folder (usually known as the current working directory). A double dot is the name of the parent folder.

```
#!/home/hpl/special/tricks/python
```

It is a good habit to always include such a first line (also called she-bang line) in all Python programs and modules, but we have not done that in this book.

H.1.3 Executing Python Programs on Windows

In a DOS window you can always run a Python program by

```
_____  
Terminal  
DOS> python prog.py arg1 arg2  
_____
```

if `prog.py` is the name of the program, and `arg1` and `arg2` are command-line arguments. The extension `.py` can be dropped:

```
_____  
Terminal  
DOS> python prog arg1 arg2  
_____
```

If there are several Python installations on your system, a particular installation can be specified:

```
_____  
Terminal  
DOS> E:\hpl\myprogs\Python2.5.3\python prog arg1 arg2  
_____
```

Files with a certain extension can on Windows be associated with a file type, and a file type can be associated with a particular program to handle the file. For example, it is natural to associate the extension `.py` with Python programs. The corresponding program needed to interpret `.py` files is then `python.exe`. When we write just the name of the Python program file, as in

```
_____  
Terminal  
DOS> prog arg1 arg2  
_____
```

the file is always interpreted by the specified `python.exe` program. The details of getting `.py` files to be interpreted by `python.exe` go as follows:

```
_____  
Terminal  
DOS> assoc .py=PyProg  
DOS> ftype PyProg=python.exe "%1" %*  
_____
```

Depending on your Python installation, such file extension bindings may already be done. You can check this with

Terminal

```
DOS> assoc | find "py"
```

To see the programs associated with a file type, write `ftype name` where `name` is the name of the file type as specified by the `assoc` command. Writing `help ftype` and `help assoc` prints out more information about these commands along with examples.

One can also run Python programs by writing just the basename of the program file, i.e., `prog.py` instead of `prog.py`, if the file extension is registered in the `PATHEXT` environment variable.

Double-Clicking Python Files. The usual way of running programs on Windows is to double click on the file icon. This does not work well with Python programs without a graphical user interface. When you double click on the icon for a file `prog.py`, a DOS window is opened, `prog.py` is interpreted by some `python.exe` program, and when the program terminates, the DOS window is closed. There is usually too little time for the user to observe the output in this short-lived DOS window.

One can always insert a final statement that pauses the program by waiting for input from the user:

```
raw_input('Type CR:')
```

or

```
sys.stdout.write('Type CR:'); sys.stdin.readline()
```

The program will “hang” until the user presses the Return key. During this pause the DOS window is visible and you can watch the output from previous statements in the program.

The downside of including a final input statement is that you must always hit Return before the program terminates. This is inconvenient if the program is moved to a Unix-type machine. One possibility is to let this final input statement be active only when the program is run on Windows:

```
if sys.platform[:3] == 'win':
    raw_input('Type CR:')
```

Python programs that have a graphical user interface can be double-clicked in the usual way if the file extension is `.pyw`.

Gnuplot Plots on Windows. Programs that call `plot` to visualize a graph with the aid of Gnuplot suffer from the same problem as described above: the plot window disappears quickly. Again, the recipe is to insert a `raw_input` call at the end of the program.

H.1.4 Executing Python Programs on Macintosh

Since a variant of Unix is used as core in the Mac OS X operating system, you can always launch a Unix terminal and use the techniques from Appendix [H.1.2](#) to run Python programs.

H.1.5 Making a Complete Stand-Alone Executable

Python programs need a Python interpreter and usually a set of modules to be installed on the computer system. Sometimes this is inconvenient, for instance when you want to give your program to somebody who does not necessarily have Python or the required set of modules installed.

Fortunately, there are tools that can create a stand-alone executable program out of a Python program. This stand-alone executable can be run on every computer that has the same type of operating system and the same chip type. Such a stand-alone executable is a bundling of the Python interpreter and the required modules, along with your program, in a single file. Details of producing this single file are given in the book [\[9\]](#).

H.2 Integer and Float Division

Many languages, including C, C++, Fortran, and classical Python, interpret the division operator in two ways:

1. *Integer division*: If both operands a and b are integers, the result a/b is the *floor* of the mathematical result a/b . This yields the largest integer that b can be multiplied with such that the product is less than or equal to a . Or phrased simpler: The result of a/b is an integer which is “rounded down”. As an example, $5/2$ becomes 2.
2. *Float division*: If one of the operands is a floating-point number or a complex number, a/b returns the mathematical result of the division.

Accidental integer division in places where mathematical division is needed, constitutes a very common source of errors in numerical programs.

It is often argued that in a statically typed language, where each variable is declared with a fixed type, the programmer always knows the type of the operands involved in a division expression. Therefore the programmer can determine whether an expression has the right form or not (the programmer can still oversee such errors). In a dynamically typed language, such as Python, variables can hold objects of any type. If a or b is provided by the user of the program, one can never know if both types end up as integer and a/b will imply integer division.

The only safe solution is to have two different operands for integer division and mathematical division. Python is currently moving in this direction. By default, `a/b` still has its original double meaning, depending on the types of operands. A new operator `//` is introduced for explicitly employing integer division. To force `a/b` to mean standard mathematical float division, one can write

```
from__future__ import division
```

This import statement must be present in every module file or script where the `/` operator always shall imply float division. Alternatively, one can run a Python program `someprogram.py` from the command line with the argument `-Qnew` to the Python interpreter:

```
Terminal> python -Qnew someprogram.py
```

The future Python 3.0 is suggested to abandon integer division interpretation of `a/b`, i.e., `a/b` will always mean the relevant float division, depending on the operands (float division for `int` and `float` operands, and complex division if one of the operands is a `complex`).

Running a Python program with the `-Qwarnall` argument, say

```
Terminal> python -Qwarnall someprogram.py
```

will print out a warning every time an integer division expression is encountered.

There are currently alternative ways out of the integer division problem:

1. If the operands involve an integer with fixed value, such as in `a/2`, the integer can be written as a floating-point number, as in `a/2.0` or `a/2.`, to enforce mathematical division regardless of whether `a` is integer, float, or complex.
2. If both operands are variables, as in `a/b`, the only safe way out of the problem is to write `1.0*a/b`. Note that `float(a)/b` or `a/float(b)` will work correctly from a mathematical viewpoint if `a` and `b` are of integer or floating-point type, but not if the argument to `float` is complex.

H.3 Visualizing a Program with Lumpy

Lumpy is a nice tool for graphically displaying the relations between the variables in a program. Consider the following program (inspired by Chapter 2.4.3), where we extract a sublist and modify the original list:

```
l0 = [1, 4, 3]
l1 = l0
l2 = l1[:-1]
l1[0] = 100
```

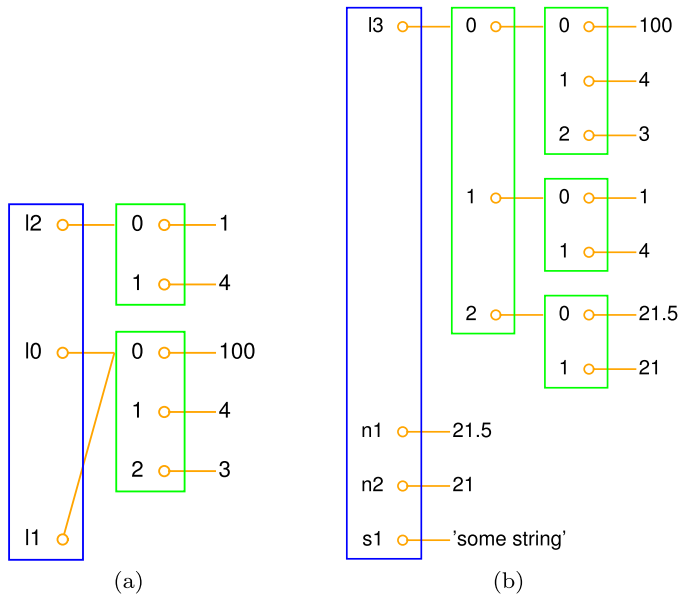

Fig. H.1 Output from Lumpy: (a) program with three lists; (b) extended program with another list, two floats, and a string.

The point is that the change in 11 is reflected in 10, but not in 12, because sublists are created by taking a copy of the original list, while 11 and 10 refer to the same object. Lumpy can visually display the variables and how they relate, and thereby making it obvious that 10 and 11 refer to the same object and that 12 is a different object. To use Lumpy, some extra statements must be inserted in the program:

```
from scitools.Lumpy import Lumpy
lumpy = Lumpy()
lumpy.make_reference()
l0 = [1, 4, 3]
l1 = l0
l2 = l1[:-1]
l1[0] = 100
lumpy.object_diagram()
```

By running this program a graphical window is shown on the screen with the variables in the program, see Figure H.1a. The variables have lines to the object they point to, and inside the objects we can see the contents, i.e., the list elements in this case.

We can add some lines to the program above and make a new, additional drawing:

```
lumpy = Lumpy()
lumpy.make_reference()
n1 = 21.5
n2 = 21
l3 = [l1, l2, [n1, n2]]
s1 = 'some string'
lumpy.object_diagram()
```

Figure [H.1b](#) shows the second object diagram with the additional variables.

We recommend to actively use Lumpy to make graphical illustrations of programs, especially if you search for an error and you are not 100% sure of how all variables related to each other.

H.4 Doing Operating System Tasks in Python

Python has extensive support for operating system tasks, such as file and folder management. The great advantage of doing operating system tasks in Python and not directly in the operating system is that the Python code works uniformly on Unix/Linux, Windows, and Mac (there are exceptions, but they are few). Below we list some useful operations that can be done inside a Python program or in an interactive session.

Make a folder:

```
import os
os.mkdir(foldername)
```

Recall that Python applies the term directory instead of folder. Ordinary files are created by the `open` and `close` functions in Python.

Make intermediate folders: Suppose you want to make a subfolder under your home folder:

```
$HOME/python/project1/temp
```

but the intermediate folders `python` and `project1` do not exist. This requires each new folder to be made separately by `os.mkdir`, or you can make all folders at once with `os.makedirs`:

```
foldername = os.path.join(os.environ['HOME'], 'python',
                           'project1', 'temp')
os.makedirs(foldername)
```

With `os.environ[var]` we can get the value of any environment variable `var` as a string.

Move to a folder:

```
origfolder = os.getcwd() # get name of current folder
os.chdir(foldername)    # move ("change directory")
...
os.chdir(origfolder)    # move back
```

Rename a file or folder:

```
os.rename(oldname, newname)
```

List files (using Unix shell wildcard notation):

```
import glob
filelist1 = glob.glob('*.py')
filelist2 = glob.glob('*[1-4]*.dat')
```

List all files and folders in a folder:

```
filelist1 = os.listdir(foldername)
filelist1 = os.listdir(os.getcwd) # current folder (directory)
```

Check if a file or folder exists:

```
if os.path.isfile(filename):
    f = open(filename)
    ...

if os.path.isdir(foldername):
    filelist = os.listdir(foldername)
    ...
```

Remove files:

```
import glob
filelist = glob.glob('tmp*.eps')
for filename in filelist:
    os.remove(filename)
```

Remove a folder and all its subfolders:

```
import shutil
shutil.rmtree(foldername)
```

It goes without saying that this command may be dangerous!

Copy a file to another file or folder:

```
shutil.copy(sourcefile, destination)
```

Copy a folder and all its subfolders:

```
shutil.copytree(sourcefolder, destination)
```

Run any operating system command:

```
cmd = 'c2f.py 21' # command to be run
failure = os.system(cmd)
if failure:
    print 'Execution of "%s" failed!\n' % cmd
    sys.exit(1)

# record output from the command:
from subprocess import Popen, PIPE
p = Popen(cmd, shell=True, stdout=PIPE)
```

```

output, errors = p.communicate()
# output contains text sent to standard output
# errors contains text sent to standard error

# process output:
for line in output.splitlines():
    # process line

# simpler recording of output on Linux/Unix:
import commands
failure, output = commands.getstatusoutput(cmd)
if failure:
    print 'Execution of "%s" failed!\n' % cmd, output
    sys.exit(1)

```

The constructions above are mainly used for running stand-alone programs. Any file or folder listing or manipulation should be done by the functionality in `os` or other modules.

Split file or folder name:

```

>>> fname = os.path.join(os.environ['HOME'], 'data', 'file1.dat')
>>> foldername, basename = os.path.split(fname)
>>> foldername
'/home/hpl/data'
>>> basename
'file1.dat'
>>> outfile = basename[:-4] + '.out'
>>> outfile
'file1.out'

```

H.5 Variable Number of Function Arguments

Arguments to Python functions are of four types:

1. positional arguments, where each argument has a name,
2. keyword arguments, where each argument has a name and a default value,
3. a variable number of positional arguments, where each argument has no name, but just a location in a list,
4. a variable number of keyword arguments, where each argument is a (name, default value) pair in a dictionary.

The corresponding general function definition can be sketched as

```
def f(pos1, pos2, key1=val1, key2=val2, *args, **kwargs):
```

Here, `pos1` and `pos2` are positional arguments, `key1` and `key2` are keyword arguments, `args` is a tuple holding a variable number of positional arguments, and `kwargs` is a dictionary holding a variable number of keyword arguments. This appendix describes how to program with the `args` and `kwargs` variables and why these are handy in many situations.

H.5.1 Variable Number of Positional Arguments

Let us start by making a function that takes an arbitrary number of arguments and computes their sum:

```
>>> def add(*args):
...     print'args:', args
...     return sum(args)
...
>>> add(1)
args: (1,)
1
>>> add(1,5,10)
args: (1, 5, 10)
16
```

We observe that `args` is a tuple and that all the arguments we provide in a call to `add` are stored in `args`.

Combination of ordinary positional arguments and a variable number of arguments is allowed, but the `*args` argument must appear after the ordinary positional arguments, e.g.,

```
def f(pos1, pos2, pos3, *args):
```

In each call to `f` we must provide at least three arguments. If more arguments are supplied in the call, these are collected in the `args` tuple inside the `f` function.

Example. Chapter 7.1.1 describes functions with parameters, e.g., $y(t; v_0) = v_0 t - \frac{1}{2}gt^2$, or the more general case $f(x; p_1, \dots, p_n)$. The Python implementation of such functions can take both the independent variable and the parameters as arguments: `y(t, v0)` and `f(x, p1, p2, ..., pn)`. Suppose that we have a general library routine that operates on functions of one variable. Relevant operations can be numerical differentiation, integration, or root finding. A simple example is a numerical differentiation function

```
def diff(f, x, h):
    return (f(x+h) - f(x))/h
```

This `diff` function cannot be used with functions `f` that take more than one argument, e.g., passing an `y(t, v0)` function as `f` leads to the exception

```
TypeError: y() takes exactly 2 arguments (1 given)
```

Chapter 7.1.1 provides a solution to this problem where `y` becomes a class instance. Here we can describe an alternative solution that allows our `y(t, v0)` function to be used as is.

The idea is that we pass additional arguments for the parameters in the `f` function *through* the `diff` function. That is, we view the `f` function as `f(x, *f_prms)`. Our `diff` routine can then be written as

```
def diff(f, x, h, *f_prms):
    print 'x:', x, 'h:', h, 'f_prms:', f_prms
    return (f(x+h, *f_prms) - f(x, *f_prms))/h
```

Before explaining this function in detail, we “prove” that it works in an example:

```
def y(t, v0):
    g = 9.81; return v0*t - 0.5*g*t**2

dydt = diff(y, 0.1, 1E-9, 3) # t=0.1, h=1E-9, v0=3
```

The output from the call to `diff` becomes

```
x: 0.1 h: 1e-09 f_prms: (3,)
```

The point is that the `v0` parameter, which we want to pass on to our `y` function, is now stored in `f_prms`. Inside the `diff` function, calling

```
f(x, *f_prms)
```

is the same as if we had written

```
f(x, f_prms[0], f_prms[1], ...)
```

That is, `*f_prms` in a call takes all the values in the tuple `*f_prms` and places them after each other as positional arguments. In the present example with the `y` function, `f(x, *f_prms)` implies `f(x, f_prms[0])`, which for the current set of argument values in our example becomes a call `y(0.1, 3)`.

For a function with many parameters,

```
def G(x, t, A, a, w):
    return A*exp(-a*t)*sin(w*x)
```

the output from

```
dGdx = diff(G, 0.5, 1E-9, 0, 1, 0.6, 100)
```

becomes

```
x: 0.5 h: 1e-09 f_prms: (0, 1, 1.5, 100)
```

We pass here the arguments `t`, `A`, `a`, and `w`, in that sequence, as the last four arguments to `diff`, and all the values are stored in the `f_prms` tuple.

The `diff` function also works for a plain function `f` with one argument:

```
from math import sin
mycos = diff(sin, 0, 1E-9)
```

In this case, `*f_prms` becomes an empty tuple, and a call like `f(x, *f_prms)` is just `f(x)`.

The use of a variable set of arguments for sending problem-specific parameters “through” a general library function, as we have demonstrated here with the `diff` function, is perhaps the most frequent use of `*args`-type arguments.

H.5.2 Variable Number of Keyword Arguments

A simple test function

```
>>> def test(**kwargs):
...     print kwargs
```

exemplifies that `kwargs` is a dictionary inside the `test` function, and that we can pass any set of keyword arguments to `test`, e.g.,

```
>>> test(a=1, q=9, method='Newton')
{'a': 1, 'q': 9, 'method': 'Newton'}
```

We can combine an arbitrary set of positional and keyword arguments, provided all the keyword arguments appear at the end of the call:

```
>>> def test(*args, **kwargs):
...     print args, kwargs
...
>>> test(1,3,5,4,a=1,b=2)
(1, 3, 5, 4) {'a': 1, 'b': 2}
```

From the output we understand that all the arguments in the call where we provide a name and a value are treated as keyword arguments and hence placed in `kwargs`, while all the remaining arguments are positional and placed in `args`.

Example. We may extend the example in Appendix H.5.1 to make use of a variable number of keyword arguments instead of a variable number of positional arguments. Suppose all functions with parameters in addition to an independent variable take the parameters as keyword arguments. For example,

```
def y(t, v0=1):
    g = 9.81; return v0*t - 0.5*g*t**2
```

In the `diff` function we transfer the parameters in the `f` function as a set of keyword arguments `**f_prms`:

```
def diff(f, x, h=1E-10, **f_prms):
    print 'x:', x, 'h:', h, 'f_prms:', f_prms
    return (f(x+h, **f_prms) - f(x, **f_prms))/h
```

In general, the `**f_prms` argument in a call

```
f(x, **f_prms)
```

implies that all the key-value pairs in `**f_prms` are provided as keyword arguments:

```
f(x, key1=f_prms[key1], key2=f_prms[key2], ...)
```

In our special case with the `y` function and the call

```
dydt = diff(y, 0.1, h=1E-9, v0=3)
```

`f(x, **f_prms)` becomes `y(0.1, v0=3)`. The output from `diff` is now

```
x: 0.1 h: 1e-09 f_prms: {'v0': 3}
```

showing explicitly that our `v0=3` in the call to `diff` is placed in the `f_prms` dictionary.

The `G` function from Appendix [H.5.1](#) can also have its parameters as keyword arguments:

```
def G(x, t=0, A=1, a=1, w=1):
    return A*exp(-a*t)*sin(w*x)
```

We can now make the call

```
dGdx = diff(G, 0.5, h=1E-9, t=0, A=1, w=100, a=1.5)
```

and view the output from `diff`,

```
x: 0.5 h: 1e-09 f_prms: {'A': 1, 'a': 1.5, 't': 0, 'w': 100}
```

to see that all the parameters get stored in `f_prms`. The `h` parameter can be placed anywhere in the collection of keyword arguments, e.g.,

```
dGdx = diff(G, 0.5, t=0, A=1, w=100, a=1.5, h=1E-9)
```

We can allow the `f` function of one variable and a set of parameters to have the general form `f(x, *f_args, **f_kwargs)`. That is, the parameters can either be positional or keyword arguments. The `diff` function must take the arguments `*f_args` and `**f_kwargs` and transfer these to `f`:

```
def diff(f, x, h=1E-10, *f_args, **f_kwargs):
    print f_args, f_kwargs
    return (f(x+h, *f_args, **f_kwargs) -
            f(x, *f_args, **f_kwargs))/h
```

This `diff` function gives the writer of an `f` function full freedom to choose positional and/or keyword arguments for the parameters. Here is an example of the `G` function where we let the `t` parameter be positional and the other parameters be keyword arguments:

```
def G(x, t, A=1, a=1, w=1):
    return A*exp(-a*t)*sin(w*x)
```

A call

```
dGdx = diff(G, 0.5, 1E-9, 0, A=1, w=100, a=1.5)
```

gives the output

```
(0,) {'A': 1, 'a': 1.5, 'w': 100}
```

showing that `t` is put in `f_args` and transferred as positional argument to `G`, while `A`, `a`, and `w` are put in `f_kwargs` and transferred as keyword arguments. We remark that in the last call to `diff`, `h` and `t` *must* be treated as positional arguments, i.e., we cannot write `h=1E-9` and `t=0` unless *all* arguments in the call are on the `name=value` form.

In the case we use both `*f_args` and `**f_kwargs` arguments in `f` and there is no need for these arguments, `*f_args` becomes an empty tuple and `**f_kwargs` becomes an empty dictionary. The example

```
mycos = diff(sin, 0)
```

shows that the tuple and dictionary are indeed empty since `diff` just prints out

```
() {}
```

Therefore, a variable set of positional and keyword arguments can be incorporated in a general library function such as `diff` without any disadvantage, just the benefit that `diff` works with different types `f` functions: parameters as global variables, parameters as additional positional arguments, parameters as additional keyword arguments, or parameters as instance variables (Chapter 7.1.2).

The program `varargs1.py` in the `appendix` folder implements the examples in this appendix.

H.6 Evaluating Program Efficiency

H.6.1 Making Time Measurements

Time is not just “time” on a computer. The *elapsed time* or *wall clock time* is the same time as you can measure on a watch or wall clock, while *CPU time* is the amount of time the program keeps the central processing unit busy. The *system time* is the time spent on operating system tasks like I/O. The concept *user time* is the difference between the CPU and system times. If your computer is occupied by many concurrent processes, the CPU time of your program might be very different from the elapsed time.

The time Module. Python has a `time` module with some useful functions for measuring the elapsed time and the CPU time:

```
import time
e0 = time.time()      # elapsed time since the epoch
c0 = time.clock()    # total CPU time spent in the program so far
<do tasks...>
elapsed_time = time.time() - e0
cpu_time = time.clock() - c0
```

The term *epoch* means initial time (`time.time()` would return 0), which is 00:00:00 January 1, 1970. The `time` module also has numerous functions for nice formatting of dates and time, and the more recent `datetime` module has more functionality and an improved interface. Although the timing has a finer resolution than seconds, one should construct test cases that last some seconds to obtain reliable results.

The timeit Module. To measure the efficiency of a certain set of statements or an expression, the code should be run a large number of times so the overall CPU-time is of order seconds. The `timeit` module has functionality for running a code segment repeatedly. Below is an illustration of `timeit` for comparing the efficiency `sin(1.2)` versus `math.sin(1.2)`:

```
>>> import timeit
>>> t = timeit.Timer('sin(1.2)', setup='from math import sin')
>>> t.timeit(1000000)    # run 'sin(1.2)' 1000000 times
11.830688953399658
>>> t = timeit.Timer('math.sin(1.2)', setup='import math')
>>> t.timeit(1000000)
16.234833955764771
```

The first argument to the `Timer` constructor is a string containing the code to execute repeatedly, while the second argument is the necessary code for initialization. From this simple test we see that `math.sin(1.2)` runs almost 40 percent slower than `sin(1.2)`!

If you want to time a function, say `f`, defined in the same program as where you have the `timeit` call, the setup procedure must import `f` and perhaps other variables from the program, as exemplified in

```
t = timeit.Timer('f(a,b)', setup='from __main__ import f, a, b')
```

Here, `f`, `a`, and `b` are names initialized in the main program. Another example is found in `src/random/smart_power.py`.

Hardware Information. Along with CPU-time measurements it is often convenient to print out information about the hardware on which the experiment was done. Python has a module `platform` with information on the current hardware. The function `scitools.misc.hardware_info` applies the `platform` module to extract relevant hardware information. A sample call is

```
>>> import scitools.misc, pprint
>>> pprint.pprint(scitools.misc.hardware_info())
{'cpuinfo':
 {'CPU speed': '1196.170 Hz',
  'CPU type': 'Mobile Intel(R) Pentium(R) III CPU - M 1200MHz',
  'cache size': '512 KB',
  'vendor ID': 'GenuineIntel'},
 'identifier': 'Linux-2.6.12-i686-with-debian-testing-unstable',
 'python build': ('r25:409', 'Feb 27 2007 19:35:40'),
 'python version': '2.5.0',
 'uname': ('Linux',
           'ubuntu',
           '2.6.12',
           '#1 Fri Nov 25 10:58:24 CET 2005',
           'i686',
           '')}
```

H.6.2 Profiling Python Programs

A profiler computes the time spent in the various functions of a program. From the timings a ranked list of the most time-consuming functions can be created. This is an indispensable tool for detecting bottlenecks in the code, and you should always perform a profiling before spending time on code optimization. The golden rule is to first write an easy-to-understand program, then verify it, then profile it, and then think about optimization².

Python comes with two profilers implemented in the `profile` and `hotshot` modules, respectively. The Python Library Reference has a good introduction to profiling in Python (Chapter 10: “The Python Profiler”). The results produced by the two alternative modules are normally processed by a special statistics utility `pstats` developed for analyzing profiling results. The usage of the `profile`, `hotshot`, and `pstats` modules is straightforward, but somewhat tedious so SciTools comes with a command `scitools profiler` that allows you to profile any program (say) `m.py` by writing

```
Terminal
Terminal> scitools profiler m.py c1 c2 c3
```

Here, `c1`, `c2`, and `c3` are command-line arguments to `m.py`.

We refer to the Python Library Reference for detailed information on how to interpret the output. A sample output might read

```
1082 function calls (728 primitive calls) in 17.890 CPU seconds
```

```
Ordered by: internal time
List reduced from 210 to 20 due to restriction <20>
```

nalls	totttime	percall	cumtime	percall	filename:lineno(function)
5	5.850	1.170	5.850	1.170	m.py:43(loop1)
1	2.590	2.590	2.590	2.590	m.py:26(empty)

² “Premature optimization is the root of all evil.” –Donald Knuth, computer scientist, 1938–.

```
5      2.510    0.502    2.510    0.502 m.py:32(myfunc2)
5      2.490    0.498    2.490    0.498 m.py:37(init)
1      2.190    2.190    2.190    2.190 m.py:13(run1)
6      0.050    0.008   17.720    2.953 funcs.py:126(timer)
...
```

In this test, `loop1` is the most expensive function, using 5.85 seconds, which is to be compared with 2.59 seconds for the next most time-consuming function, `empty`. The `tottime` entry is the total time spent in a specific function, while `cumtime` reflects the total time spent in the function and all the functions it calls.

The CPU time of a Python program typically increases with a factor of about five when run under the administration of the `profile` module. Nevertheless, the relative CPU time among the functions are probably not much affected by the profiler overhead.

References

- [1] D. Beazley. *Python Essential Reference*. SAMS, Indianapolis, 2nd edition, 2001.
- [2] J. E. Grayson. *Python and Tkinter Programming*. Manning, Greenwich, 2000.
- [3] D. Harms and K. McDonald. *The Quick Python Book*. Manning, Greenwich, 1999.
- [4] D. E. Knuth. Theory and practice. *EATCS Bull.*, 27:14–21, 1985.
- [5] H. P. Langtangen. *Python Scripting for Computational Science*, volume 3 of *Texts in Computational Science and Engineering*. Springer, Berlin, 3rd edition, 2009.
- [6] L. S. Lerner. *Physics for Scientists and Engineers*. Jones and Bartlett, Sudbury, 1996.
- [7] M. Lutz. *Programming Python*. O'Reilly, Sebastopol, 2nd edition, 2001.
- [8] M. Lutz and D. Ascher. *Learning Python*. O'Reilly, Sebastopol, 1999.
- [9] A. Martelli. *Python in a Nutshell*. O'Reilly, Sebastopol, 2003.
- [10] J.D. Murray. *Mathematical Biology I: An Introduction*. Springer, Berlin, 3rd edition, 2007.
- [11] F.M. White. *Fluid Mechanics*. McGraw-Hill, New York, 2nd edition, 1986.

Index

- `**kwargs`, 779
- `*=`, 52
- `*args`, 777
- `+=`, 52
- `-=`, 52
- `/=`, 52
- `\n`, 14

- allocate, 195
- animate, 457
- API, 381
- `aplotter` (from `scitools`), 214
- `append` (list), 56
- application, 15
- application programming interface, 381
- `argparse` module, 149
- `array` (from `numpy`), 194
- array computing, 194
- array (datatype), 194
- array shape, 230, 231
- array slicing, 195
- `asarray` (from `numpy`), 228
- attribute (class), 346
- average, 418

- backend (Easyviz), 205, 208
- base class, 484
- bin (histogram), 416
- binomial distribution, 185
- bioinformatics, 107

- bits, 263
- blank lines in files, 285
- blanks, 17
- body of a function, 88
- boolean expressions, 53
- boolean indexing, 223, 224
- `break`, 260
- bytes, 263

- callable objects, 361
- callback function, 651
- check an object's type, 29, 229, 382, 487
- check file/folder existence (in Python), 775
- class hierarchy, 483
- class relationship
 - derived class, 484
 - has-a, 488
 - inheritance, 484
 - is-a, 488
 - subclass, 484
 - superclass, 484
- closure, 502
- `cmath` module, 33
- command-line arguments, 145
- `commands` module, 775
- comments, 10
- comparing
 - floating-point numbers, 84

- comparing (*cont.*)
 - objects, 84
 - real numbers, 84
- complex numbers, 32
- concatenate (from `numpy`), 580
- console (terminal) window, 4
- constructor (class), 345
- convergence rate, 553, 716
- convert program, 457
- copy files (in Python), 775
- copy folders (in Python), 775
- CPU time measurements, 114, 781
- cumulative sum, 471
- curve plotting, 198
-
- `datetime` module, 273, 560, 782
- debugger tour, 735
- `del`, 56
- delete files (in Python), 213, 407, 775
- delete folders (in Python), 775
- derived class, 484
- dictionary, 266, 308
 - comprehensions, 270
 - functionality, 324
 - nested, 275
- difference equations, 558
 - nonlinear, 576
- differential equations, 625, 667, 668, 677
- `dir` function, 386
- directory, 1, 4, 774
- DNA, 107
- doc strings, 99
- `dtype`, 228
- duck typing, 384
- dynamic binding, 495
- dynamic typing, 383
-
- editor, 3
- efficiency, 781
- efficiency measure, 450
- elapsed time, 781
- `enumerate` function, 63, 404
- environment variables, 774
-
- `eval` function, 139, 496
- event loop, 160
- `except`, 153
- `Exception`, 157
- exceptions, 153
- execute programs (from Python), 775
- execute Python program, 7, 30, 767
- expression, 16
-
- factorial, 54
- `factorial` function, 126
- factory function, 497
- `find` (string method), 283
- first-order ODEs, 634
- `float_eq`, 84
- `format` (string method), 13
- format string syntax, 13
- formatting text and numbers, 11
- Forward Euler scheme, 670
- Fourier series, 124
- frequency matrix, 305
- function arguments
 - keyword, 97
 - named, 97
 - positional, 97
- function body, 88
- function header, 88
- function inside function, 689
- functional programming, 502
-
- Gaussian function, 45
- `glob.glob` function, 407, 775
- `global`, 90
- `globals` function, 89, 220, 656
- grid, 594
-
- has-a class relationship, 488
- Heaviside function, 128
- heterogeneous lists, 193
- histogram (normalized), 416
-
- Idle, 4
- immutable objects, 269, 371
- in-place array arithmetics, 227
- `IndexError`, 154, 155

- information hiding, 381
- initial condition, 558, 626, 646
- input (data), 18
- insert (list), 56
- instance (class), 346
- integer random numbers, 420
- interactive sessions
 - IPython, 29
 - standard Python shell, 27
- interpolation, 246
- interval arithmetics, 391
- IPython, 29
- is, 96
- is-a class relationship, 488
- isdigit (string method), 285
- isinstance function, 73, 229, 382, 487
- isspace (string method), 285
- join (string method), 285
- keys (dictionaries), 267
- keyword arguments, 97, 776
- Lagrange's interpolation formula, 246
- lambda functions, 103, 106
- least squares approximation, 330
- len (list), 56
- line break, 14
- linspace (from numpy), 195, 230
- list, nested, 64
- list comprehension, 63, 66, 111
- list files (in Python), 775
- list functionality, 73
- list iteration, 107
- lists, 55
- logical expressions, 53
- loops, 50
- lower (string method), 284
- lstrip (string method), 285
- Mac OS X, 18
- main program, 102
- make a folder (in Python), 774
- making graphs, 198
- making movie, 457
- math module, 24
- mean, 418
- mean (from numpy), 419, 460
- measure time in programs, 450
- mesh, 594
- method (class), 58
- method (in class), 346
- mod function, 119, 419
- module folders, 168
- modules, 161
- Monte Carlo integration, 446
- Monte Carlo simulation, 428
- move to a folder (in Python), 774
- multiple inheritance, 552
- mutable objects, 269, 371
- named arguments, 97
- NameError, 155
- namespace, 354
- nested dictionaries, 275
- nested lists, 65
- nested loops, 70
- newline character (line break), 14
- Newton's method, 363, 572
- None, 96
- nonlinear difference equations, 576
- normal (from numpy.random), 420
- normally distributed random numbers, 419
- not, 53
- np prefix (numpy), 194
- np.array function, 194
- np.linspace function, 195
- np.zeros function, 194
- np.zeros_like function, 195
- Numerical Python, 194
- NumPy, 194
- numpy, 194
- numpy.lib.scimath module, 34
- object-based programming, 483
- object-oriented programming, 483
- objects, 21
- ODE, 625, 667

- operating system (OS), 18
- optimization of Python code, 783
- option-value pairs (command line), 148
- OrderedDict class, 268
- ordinary differential equations, 625, 667, 668
- os module, 774
- os.chdir function, 774
- os.listdir function, 775
- os.makedirs function, 774
- os.mkdir function, 774
- os.pardir, 169
- os.path.isdir function, 775
- os.path.isfile function, 775
- os.path.join function, 169, 774
- os.path.split function, 776
- os.remove function, 213, 407, 775
- os.rename function, 774
- os.system function, 775
- oscillating systems, 634, 641, 648, 700
- output (data), 18
- overloading (of methods), 506

- parent class, 484
- pass, 381
- plot (from scitools), 205
- plotting, 198
- Poisson distribution, 185
- polymorphism, 506
- positional arguments, 97, 776
- pprint.pformat, 67
- pprint.pprint, 66
- pprint2 (from scitools), 66
- pretty print, 66
- printf syntax, 11
- private attributes (class), 381
- probability, 428
- profiler.py, 783
- profiling, 783
- protected attributes (class), 371, 381
- pydoc program, 78
- Python Online Tutor, 109

- r_ (array creation), 230
- raise, 156
- randint (from numpy.random), 455
- randn (from numpy.random), 420
- random module, 414
- random (from numpy.random), 417
- random (from numpy), 417
- random numbers, 413
 - histogram, 416
 - integers, 420
 - integration, 446
 - Monte Carlo simulation, 428
 - normal distribution, 419
 - random walk, 451
 - statistics, 418
 - uniform distribution, 415
 - vectorization, 417
- random strings, 113
- random walk, 451
- random.normalvariate function, 420
- random_integers (from numpy.random), 455
- raw_input function, 138
- refactoring, 176
- remove files (in Python), 213, 407, 775
- remove folders (in Python), 775
- rename file/folder (in Python), 774
- replace (string method), 283
- resolution (mesh), 594
- round function, 29
- round-off errors, 26
- rounding float to integer, 29
- rstrip (string method), 285
- run programs (from Python), 775
- run Python program, 7, 30, 767

- scalar code, 197
- scalar differential equation, 668
- scalar differential equations, 634
- scalar function, 668
- scalar (math. quantity), 190
- scaling, 565

- scitools.pprint2 module, 66
- scitools.pprint2.pprint, 67
- scitools.std, 204
- search for module files, 168
- Secant method, 587
- second-order ODEs, 634, 645, 700
- seed, 414
- sequence (data type), 74
- sequence (mathematical), 557
- shape (of an array), 230, 231
- shutil.copy function, 775
- shutil.copypath function, 775
- shutil.rmtree function, 775
- \sum notation, 74
- slicing, 67, 283
- sort (list), 131
- source code, 14
- special methods (in classes), 360
- split (string method), 284
- split filename, 776
- spread of a disease (model), 637
- standard deviation, 418
- standard error, 299
- standard input, 298
- standard output, 298
- statements, 16
- static class attributes, 387
- static class methods, 388
- static class variables, 387
- static typing, 383
- std (from numpy), 419, 460
- str2obj (from scitools), 170
- string, 11
 - case change, 284
 - joining list elements, 285
 - searching, 283
 - splitting, 284
 - stripping leading/trailing blanks, 285
 - substitution, 283
 - substrings, 283
 - testing for number, 285
- string iteration, 108
- string slicing, 283
- StringFunction (from scitools), 144
- strip (string method), 285
- strong typing, 383
- subarrays, 195
- subclass, 484
- sublist, 67
- subprocess module, 775
- substitution (in text), 283
- substrings, 283
- sum, 111
- sum iterator, 112
- sum (from numpy), 422
- superclass, 484
- syntax, 17
- SyntaxError, 155
- sys module, 145
- sys.argv, 145
- sys.exit function, 152
- sys.path, 168
- sys.stderr, 299
- sys.stdin, 298
- sys.stdout, 298
- system time, 781
- systems of differential equations, 634, 677
- terminal window, 4
- test block (in module files), 163
- time module, 85, 115, 450, 452, 782
- time
 - CPU, 781
 - elapsed, 781
 - system, 781
 - user, 781
- timeit module, 782
- timing utilities, 781
- triple-quoted strings, 13
- try, 153
- tuples, 71
- type function, 29, 73
- type conversion, 28
- TypeError, 155

- UML class diagram, 345
- `uniform` (from `numpy.random`), 417
- uniformly distributed random numbers, 415
- Unix, 19
- `upper` (string method), 284
- `urllib`, 316
- user (of a program), 18
- user time, 781
- user-defined datatype (class), 346
- using a debugger, 109, 735
- `_v1` (version numbering), 20
- `ValueError`, 154, 155
- `var` (from `numpy`), 419, 460
- variable no. of function arguments, 776
- variance, 418
- vector computing, 189
- vectorization, 194, 196
- vectorized drawing of random numbers, 417
- vectors, 188
- weak typing, 383
- `where` (from `numpy`), 223
- whitespace, 17, 18, 285
- widgets, 159
- Windows, 18
- `wrap2callable` function, 403
- `wrap2callable`, 672
- wrapper code, 365
- `xrange` function, 196, 422
- `ZeroDivisionError`, 155
- `zeros` (from `numpy`), 194
- `zeros_like` (from `numpy`), 195
- `zip` function, 64
- zombies, 722

Editorial Policy

§1. Textbooks on topics in the field of computational science and engineering will be considered. They should be written for courses in CSE education. Both graduate and undergraduate textbooks will be published in TCSE. Multidisciplinary topics and multidisciplinary teams of authors are especially welcome.

§2. Format: Only works in English will be considered. For evaluation purposes, manuscripts may be submitted in print or electronic form, in the latter case, preferably as pdf- or zipped ps- files. Authors are requested to use the LaTeX style files available from Springer at: <http://www.springer.com/authors/book+authors?SGWID=0-154102-12-417900-0> (for monographs, textbooks and similar)

Electronic material can be included if appropriate. Please contact the publisher.

§3. Those considering a book which might be suitable for the series are strongly advised to contact the publisher or the series editors at an early stage.

General Remarks

Careful preparation of manuscripts will help keep production time short and ensure a satisfactory appearance of the finished book.

The following terms and conditions hold:

Regarding free copies and royalties, the standard terms for Springer mathematics textbooks hold. Please write to martin.peters@springer.com for details.

Authors are entitled to purchase further copies of their book and other Springer books for their personal use, at a discount of 33.3 % directly from Springer-Verlag.

Series Editors

Timothy J. Barth
NASA Ames Research Center
NAS Division
Moffett Field, CA 94035, USA
barth@nas.nasa.gov

Michael Griebel
Institut für Numerische Simulation
der Universität Bonn
Wegelerstr. 6
53115 Bonn, Germany
griebel@ins.uni-bonn.de

David E. Keyes
Mathematical and Computer Sciences
and Engineering
King Abdullah University of Science
and Technology
P.O. Box 55455
Jeddah 21534, Saudi Arabia
david.keyes@kaust.edu.sa

and

Department of Applied Physics
and Applied Mathematics
Columbia University
500 W. 120th Street
New York, NY 10027, USA
kd2112@columbia.edu

Risto M. Nieminen
Department of Applied Physics
Aalto University School of Science
and Technology
00076 Aalto, Finland
risto.nieminen@tkk.fi

Dirk Roose
Department of Computer Science
Katholieke Universiteit Leuven
Celestijnenlaan 200A
3001 Leuven-Heverlee, Belgium
dirk.roose@cs.kuleuven.be

Tamar Schlick
Department of Chemistry
and Courant Institute
of Mathematical Sciences
New York University
251 Mercer Street
New York, NY 10012, USA
schlick@nyu.edu

Editor for Computational Science
and Engineering at Springer:
Martin Peters
Springer-Verlag
Mathematics Editorial IV
Tiergartenstrasse 17
69121 Heidelberg, Germany
martin.peters@springer.com

Texts in Computational Science and Engineering

1. H. P. Langtangen, *Computational Partial Differential Equations*. Numerical Methods and Diffpack Programming. 2nd Edition
2. A. Quarteroni, F. Saleri, P. Gervasio, *Scientific Computing with MATLAB and Octave*. 3rd Edition
3. H. P. Langtangen, *Python Scripting for Computational Science*. 3rd Edition
4. H. Gardner, G. Manduchi, *Design Patterns for e-Science*.
5. M. Griebel, S. Knapek, G. Zumbusch, *Numerical Simulation in Molecular Dynamics*.
6. H. P. Langtangen, *A Primer on Scientific Programming with Python*. 3rd Edition
7. A. Tveito, H. P. Langtangen, B. F. Nielsen, X. Cai, *Elements of Scientific Computing*.
8. B. Gustafsson, *Fundamentals of Scientific Computing*.
9. M. Bader, *Space-Filling Curves*.

For further information on these books please have a look at our mathematics catalogue at the following URL:
www.springer.com/series/5151

Monographs in Computational Science and Engineering

1. J. Sundnes, G.T. Lines, X. Cai, B.F Nielsen, K.-A. Mardal, A. Tveito, *Computing the Electrical Activity in the Heart*.

For further information on this book, please have a look at our mathematics catalogue at the following URL:
www.springer.com/series/7417

Lecture Notes in Computational Science and Engineering

1. D. Fimaro, *Spectral Elements for Transport-Dominated Equations*.
2. H.P Langtangen, *Computational Partial Differential Equations*. Numerical Methods and Diffpack Programming.
3. W. Hackbusch, G. Wittum (eds.), *Multigrid Methods V*.
4. P. Deuffhard, J. Hermans, B. Leimkuhler, A.E. Mark, S. Reich, R.D. Skeel (eds.), *Computational Molecular Dynamics: Challenges, Methods, Ideas*.

5. D. Kröner, M. Ohlberger, C. Rohde (eds.), *An Introduction to Recent Developments in Theory and Numerics for Conservation Laws*.
6. S. Turek, *Efficient Solvers for Incompressible Flow Problems*. An Algorithmic and Computational Approach.
7. R. von Schwerin, *Multi Body System SIMulation*. Numerical Methods, Algorithms, and Software.
8. H.-J. Bungartz, F. Durst, C. Zenger (eds.), *High Performance Scientific and Engineering Computing*.
9. T.J. Barth, H. Deconinck (eds.), *High-Order Methods for Computational Physics*.
10. H.P. Langtangen, A.M. Bruaset, E. Quak (eds.), *Advances in Software Tools for Scientific Computing*.
11. B. Cockburn, G.E. Karniadakis, C.-W. Shu (eds.), *Discontinuous Galerkin Methods*. Theory, Computation and Applications.
12. U. van Rienen, *Numerical Methods in Computational Electrodynamics*. Linear Systems in Practical Applications.
13. B. Engquist, L. Johnsson, M. Hammill, F. Short (eds.), *Simulation and Visualization on the Grid*.
14. E. Dick, K. Rienslagh, J. Vierendeels (eds.), *Multigrid Methods VI*.
15. A. Frommer, T. Lippert, B. Medeke, K. Schilling (eds.), *Numerical Challenges in Lattice Quantum Chromodynamics*.
16. J. Lang, *Adaptive Multilevel Solution of Nonlinear Parabolic PDE Systems*. Theory, Algorithm, and Applications.
17. B.I. Wohlmuth, *Discretization Methods and Iterative Solvers Based on Domain Decomposition*.
18. U. van Rienen, M. Günther, D. Hecht (eds.), *Scientific Computing in Electrical Engineering*.
19. I. Babuška, P.G. Ciarlet, T. Miyoshi (eds.), *Mathematical Modeling and Numerical Simulation in Continuum Mechanics*.
20. T.J. Barth, T. Chan, R. Haimes (eds.), *Multiscale and Multiresolution Methods*. Theory and Applications.
21. M. Breuer, F. Durst, C. Zenger (eds.), *High Performance Scientific and Engineering Computing*.
22. K. Urban, *Wavelets in Numerical Simulation*. Problem Adapted Construction and Applications.
23. L.F. Pavarino, A. Toselli (eds.), *Recent Developments in Domain Decomposition Methods*.
24. T. Schlick, H.H. Gan (eds.), *Computational Methods for Macromolecules: Challenges and Applications*.
25. T.J. Barth, H. Deconinck (eds.), *Error Estimation and Adaptive Discretization Methods in Computational Fluid Dynamics*.
26. M. Griebel, M.A. Schweitzer (eds.), *Meshfree Methods for Partial Differential Equations*.
27. S. Müller, *Adaptive Multiscale Schemes for Conservation Laws*.
28. C. Carstensen, S. Funken, W. Hackbusch, R.H.W. Hoppe, P. Monk (eds.), *Computational Electromagnetics*.
29. M.A. Schweitzer, *A Parallel Multilevel Partition of Unity Method for Elliptic Partial Differential Equations*.
30. T. Biegler, O. Ghattas, M. Heinkenschloss, B. van Bloemen Waanders (eds.), *Large-Scale PDE-Constrained Optimization*.
31. M. Ainsworth, P. Davies, D. Duncan, P. Martin, B. Rynne (eds.), *Topics in Computational Wave Propagation*. Direct and Inverse Problems.
32. H. Emmerich, B. Nestler, M. Schreckenberg (eds.), *Interface and Transport Dynamics*. Computational Modelling.

33. H.P. Langtangen, A. Tveito (eds.), *Advanced Topics in Computational Partial Differential Equations*. Numerical Methods and Diffpack Programming.
34. V. John, *Large Eddy Simulation of Turbulent Incompressible Flows*. Analytical and Numerical Results for a Class of LES Models.
35. E. Bänsch (ed.), *Challenges in Scientific Computing – CISC 2002*.
36. B.N. Khoromskij, G. Wittum, *Numerical Solution of Elliptic Differential Equations by Reduction to the Interface*.
37. A. Iske, *Multiresolution Methods in Scattered Data Modelling*.
38. S.-I. Niculescu, K. Gu (eds.), *Advances in Time-Delay Systems*.
39. S. Attinger, P. Koumoutsakos (eds.), *Multiscale Modelling and Simulation*.
40. R. Kornhuber, R. Hoppe, J. Périaux, O. Pironneau, O. Wildlund, J. Xu (eds.), *Domain Decomposition Methods in Science and Engineering*.
41. T. Plewa, T. Linde, V.G. Weirs (eds.), *Adaptive Mesh Refinement – Theory and Applications*.
42. A. Schmidt, K.G. Siebert, *Design of Adaptive Finite Element Software*. The Finite Element Toolbox ALBERTA.
43. M. Griebel, M.A. Schweitzer (eds.), *Meshfree Methods for Partial Differential Equations II*.
44. B. Engquist, P. Lötstedt, O. Runborg (eds.), *Multiscale Methods in Science and Engineering*.
45. P. Benner, V. Mehrmann, D.C. Sorensen (eds.), *Dimension Reduction of Large-Scale Systems*.
46. D. Kressner, *Numerical Methods for General and Structured Eigenvalue Problems*.
47. A. Boriçi, A. Frommer, B. Joo, A. Kennedy, B. Pendleton (eds.), *QCD and Numerical Analysis III*.
48. F. Graziani (ed.), *Computational Methods in Transport*.
49. B. Leimkuhler, C. Chipot, R. Elber, A. Laaksonen, A. Mark, T. Schlick, C. Schutte, R. Skeel (eds.), *New Algorithms for Macromolecular Simulation*.
50. M. Bücker, G. Corliss, P. Hovland, U. Naumann, B. Norris (eds.), *Automatic Differentiation: Applications, Theory, and Implementations*.
51. A.M. Bruaset, A. Tveito (eds.), *Numerical Solution of Partial Differential Equations on Parallel Computers*.
52. K.H. Hoffmann, A. Meyer (eds.), *Parallel Algorithms and Cluster Computing*.
53. H.-J. Bungartz, M. Schafer (eds.), *Fluid-Structure Interaction*.
54. J. Behrens, *Adaptive Atmospheric Modeling*.
55. O. Widlund, D. Keyes (eds.), *Domain Decomposition Methods in Science and Engineering XVI*.
56. S. Kassinos, C. Langer, G. Iaccarino, P. Moin (eds.), *Complex Effects in Large Eddy Simulations*.
57. M. Griebel, M.A. Schweitzer (eds.), *Meshfree Methods for Partial Differential Equations III*.
58. A.N. Gorban, B. Kégl, D.C. Wunsch, A. Zinovyev (eds.), *Principal Manifolds for Data Visualization and Dimension Reduction*.
59. H. Ammari (ed.), *Modeling and Computations in Electromagnetics: A Volume Dedicated to Jean-Claude Nédélec*.
60. U. Langer, M. Discacciati, D. Keyes, O. Widlund, W. Zulehner (eds.), *Domain Decomposition Methods in Science and Engineering XVII*.
61. T. Mathew, *Domain Decomposition Methods for the Numerical Solution of Partial Differential Equations*.

62. F. Graziani (ed.), *Computational Methods in Transport: Verification and Validation*.
63. M. Bebendorf, *Hierarchical Matrices. A Means to Efficiently Solve Elliptic Boundary Value Problems*.
64. C.H. Bischof, H.M. Bücker, P. Hovland, U. Naumann, J. Utke (eds.), *Advances in Automatic Differentiation*.
65. M. Griebel, M.A. Schweitzer (eds.), *Meshfree Methods for Partial Differential Equations IV*.
66. B. Engquist, P. Lötstedt, O. Runborg (eds.), *Multiscale Modeling and Simulation in Science*.
67. I.H. Tuncer, Ü. Güllat, D.R. Emerson, K. Matsuno (eds.), *Parallel Computational Fluid Dynamics 2007*.
68. S. Yip, T. Diaz de la Rubia (eds.), *Scientific Modeling and Simulations*.
69. A. Hegarty, N. Kopteva, E. O’Riordan, M. Stynes (eds.), *BAIL 2008 – Boundary and Interior Layers*.
70. M. Bercovier, M.J. Gander, R. Kornhuber, O. Widlund (eds.), *Domain Decomposition Methods in Science and Engineering XVIII*.
71. B. Koren, C. Vuik (eds.), *Advanced Computational Methods in Science and Engineering*.
72. M. Peters (ed.), *Computational Fluid Dynamics for Sport Simulation*.
73. H.-J. Bungartz, M. Mehl, M. Schafer (eds.), *Fluid Structure Interaction II – Modelling, Simulation, Optimization*.
74. D. Tromeur-Dervout, G. Brenner, D.R. Emerson, J. Erhel (eds.), *Parallel Computational Fluid Dynamics 2008*.
75. A.N. Gorbunov, D. Roose (eds.), *Coping with Complexity: Model Reduction and Data Analysis*.
76. J.S. Hesthaven, E.M. Rønquist (eds.), *Spectral and High Order Methods for Partial Differential Equations*.
77. M. Holtz, *Sparse Grid Quadrature in High Dimensions with Applications in Finance and Insurance*.
78. Y. Huang, R. Kornhuber, O. Widlund, J. Xu (eds.), *Domain Decomposition Methods in Science and Engineering XIX*.
79. M. Griebel, M.A. Schweitzer (eds.), *Meshfree Methods for Partial Differential Equations V*.
80. P.H. Lauritzen, C. Jablonowski, M.A. Taylor, R.D. Nair (eds.), *Numerical Techniques for Global Atmospheric Models*.
81. C. Clavero, J.L. Gracia, F. Lisbona (eds.), *BAIL 2010 – Boundary and Interior Layers, Computational and Asymptotic Methods*.
82. B. Engquist, O. Runborg, Y.R. Tsai (eds.), *Numerical Analysis and Multiscale Computations*.
83. I.G. Graham, T.Y. Hou, O. Lakkis, R. Scheichl (eds.), *Numerical Analysis of Multiscale Problems*.
84. A. Logg, K.-A. Mardal, G.N. Wells (eds.), *Automated Solution of Differential Equations by the Finite Element Method*.
85. J. Blowey, M. Jensen (eds.), *Frontiers in Numerical Analysis – Durham 2010*.
86. O. Kolditz, U.-J. Gorke, H. Shao, W. Wang (eds.), *Thermo-Hydro-Mechanical-Chemical Processes in Fractured Porous Media – Benchmarks and Examples*.
87. S. Forth, P. Hovland, E. Phipps, J. Utke, A. Walther (eds.), *Recent Advances in Algorithmic Differentiation*.
88. J. Garcke, M. Griebel (eds.), *Sparse Grids and Applications*.

For further information on these books please have a look at our mathematics catalogue at the following URL:
www.springer.com/series/3527